

# OVAL BAR INSTALLATION

2015-2017 Ford F150 Supercab/Ext. Cab 4dr Aluminum Body

2017 Superduty Supercab/Ext. Cab Aluminum Body

**DO NOT USE IMPACT TOOLS**

**OB1034X**  
5/17/17

## Hardware Kit Includes:

- (1) 8 – Hex head bolts (10mm – 1.5 x 30mm)
- (2) 8 – Lock washers (10mm)
- (3) 8 – Flat washers (10mm)
- (4) 4 – Rubber gaskets
- (5) 8– Hex head nuts (M8-1.25)
- (6) 8 – Lock washers (8mm)
- (7) 8 – Flat washers (8mm)

## Components List:

- 2 – Stainless steel oval step bars
- 2 – Ford F150 mounting brackets (PN2315)
- 2 – Ford F150 mounting brackets (PN2314)
- 8 – Gasket (PN2331)

**DISCLAIMER: USE ONLY COMPONENTS AND HARDWARE SUPPLIED. NO SUBSTITUTIONS.**

**LOOSE FIT ALL COMPONENTS. DO NOT TIGHTEN UNTIL ALL COMPONENTS ARE INSTALLED AND ADJUSTED.**

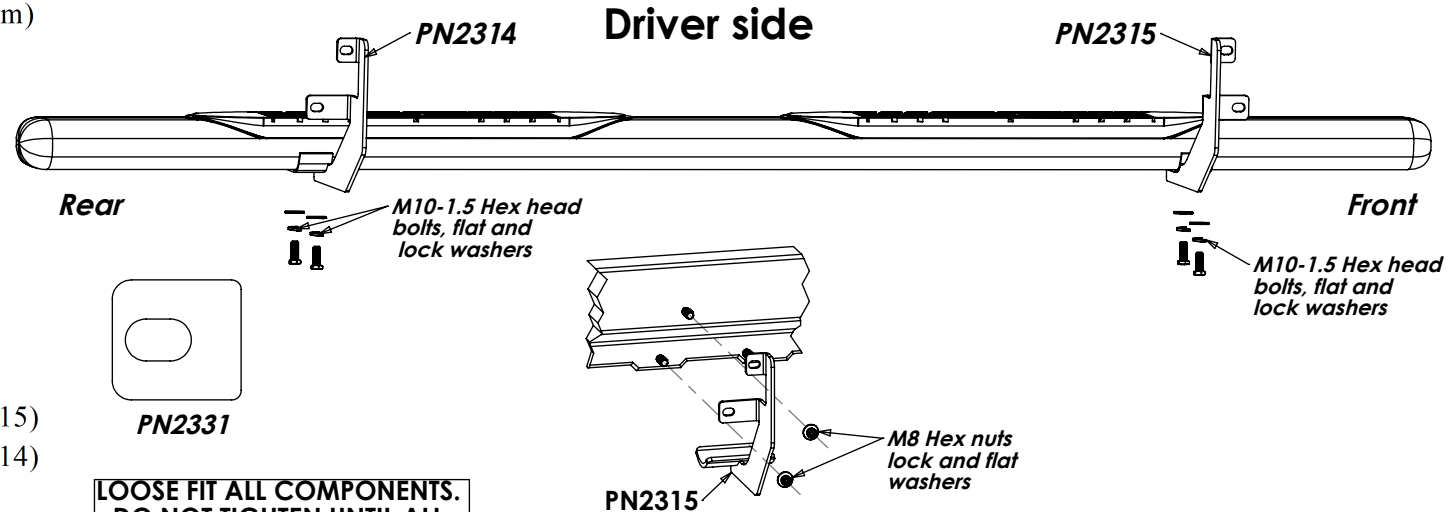

- STEP 1.** Read and understand instructions completely before beginning installation. Layout hardware kit and identify all components prior to installation.
- STEP 2.** Starting on the Driver side locate mounting points on the inside rocker panel. There are two sets of 8mm-1.25 studs pre-installed from the factory. Using (2) of the supplied M8-1.25 Hex head nuts, lock and flat washers, attach by hand one on the (PN2315) mounting brackets to the driver side front mounting studs on the inside rocker panel (Cupped bracket should face reward). Carefully thread the M8 hex head nut onto the factory stud taking care not to cross thread or strip the factory stud. Factory studs may have a significant amount of paint on them preventing the nuts from threading on cleanly. ICI recommends cleaning the threads with a M8-1.25 die prior to installation, or thread nuts on partially, then back them off of the studs to help clean off the threads, you may have to repeat several times for each stud. Leave slightly loose until all brackets and boards are attached. **(DO NOT USE IMPACT TOOLS)**
- STEP 3.** Next install brackets PN2314 onto the rear mounting positions on the inside rocker panel (cupped bracket should face forward). Again use caution when threading hardware onto the factory studs as outlined in step 3 to prevent damaging them.
- STEP 4.** Now loosely install the Driver side oval bar to the (PN2315/2314) utilizing the supplied M10 hex head bolts, lock and flat washers. Place supplied rubber gaskets in between the bar and the cupped portion of the mounting bracket. Once all hardware is loosely fit align bar and tighten all hardware, do not over tighten.
- STEP 5.** Next move to the passenger side and again locate mounting points on the inside rocker panel. There are two sets of 8mm-1.25 studs pre-installed from the factory. Using (2) of the supplied M8-1.25 Hex head nuts, lock and flat washers, attach by hand one on the (PN2314) mounting brackets to the passenger front mounting studs on the inside rocker panel. Carefully thread the M8 hex head nut onto the factory stud taking care not to cross thread or strip the factory stud. Factory studs may have a significant amount of paint on them preventing the nuts from threading on cleanly. ICI recommends cleaning the threads with a M8-1.25 die prior to installation, or thread nuts on partially, then back them off of the studs to help clean off the threads, you may have to repeat several times for each stud. Leave slightly loose until all brackets and boards are attached. **(DO NOT USE IMPACT TOOLS)**
- STEP 6.** Next install brackets PN2315 onto the rear mounting positions on the inside rocker panel. Again use caution when threading hardware onto the factory studs as outlined in step 3 to prevent damaging them.
- STEP 7.** Now loosely install the passenger side oval bar to the (PN2314/2315) utilizing the supplied M10 hex head bolts, lock and flat washers. Place supplied rubber gaskets in between the bar and the cupped portion of the mounting bracket. Once all hardware is loosely fit align bar and tighten all hardware, do not over tighten. Installation is now complete.