

CHAMBERLAIN®

# LiftMaster® PROFESSIONAL

## APPLICATION REQUIREMENTS:

This modification is available to all LA400 North American gate operators.

## FUNCTION:

Allows existing LA400 control board in the field to be replaced or upgraded with a new LA400 control board.

# Control Board Replacement Kit K001A6039

## INSTALLATION INSTRUCTIONS

### WARNING

To prevent possible SERIOUS INJURY or DEATH from electrocution or fire, disconnect power at the fuse box BEFORE proceeding.

### REMOVE EXISTING BOARD

1. Remove screws in each corner and open control box cover (Figure 1).
2. Disconnect terminals leads to both batteries and the 24VAC or solar input at the board.
3. Remove the coaxial cable going to the antenna at the board F connector (Figure 2).
4. Remove all quick connect terminals in use to the logic board (Figure 2).
  - Wiring terminals
  - Motor connectors
  - Alarms
  - Reset terminals

**NOTE:** Remember location of all wire connections for reinstallation.

5. Disconnect the earth ground wire from the board connector (J4).
6. Remove the screws (4) that fasten the control board to the mounting bracket and remove the existing control board.

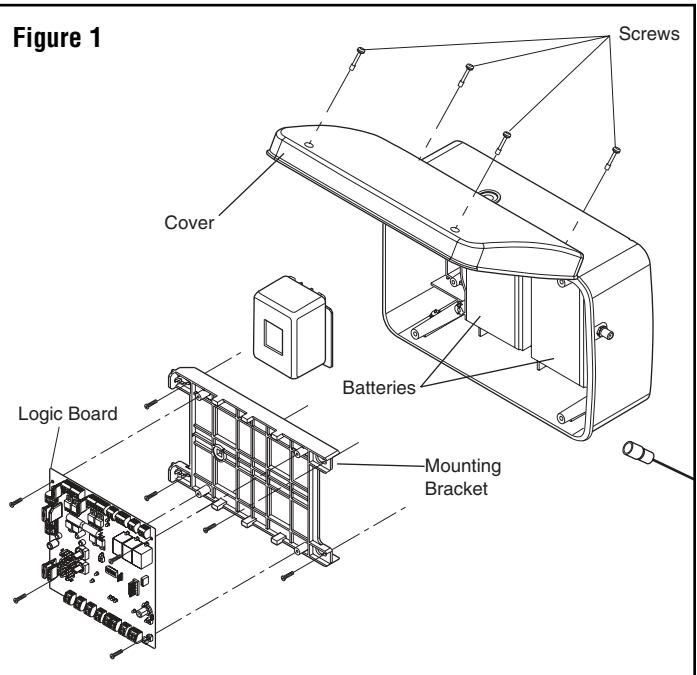

**Figure 2**

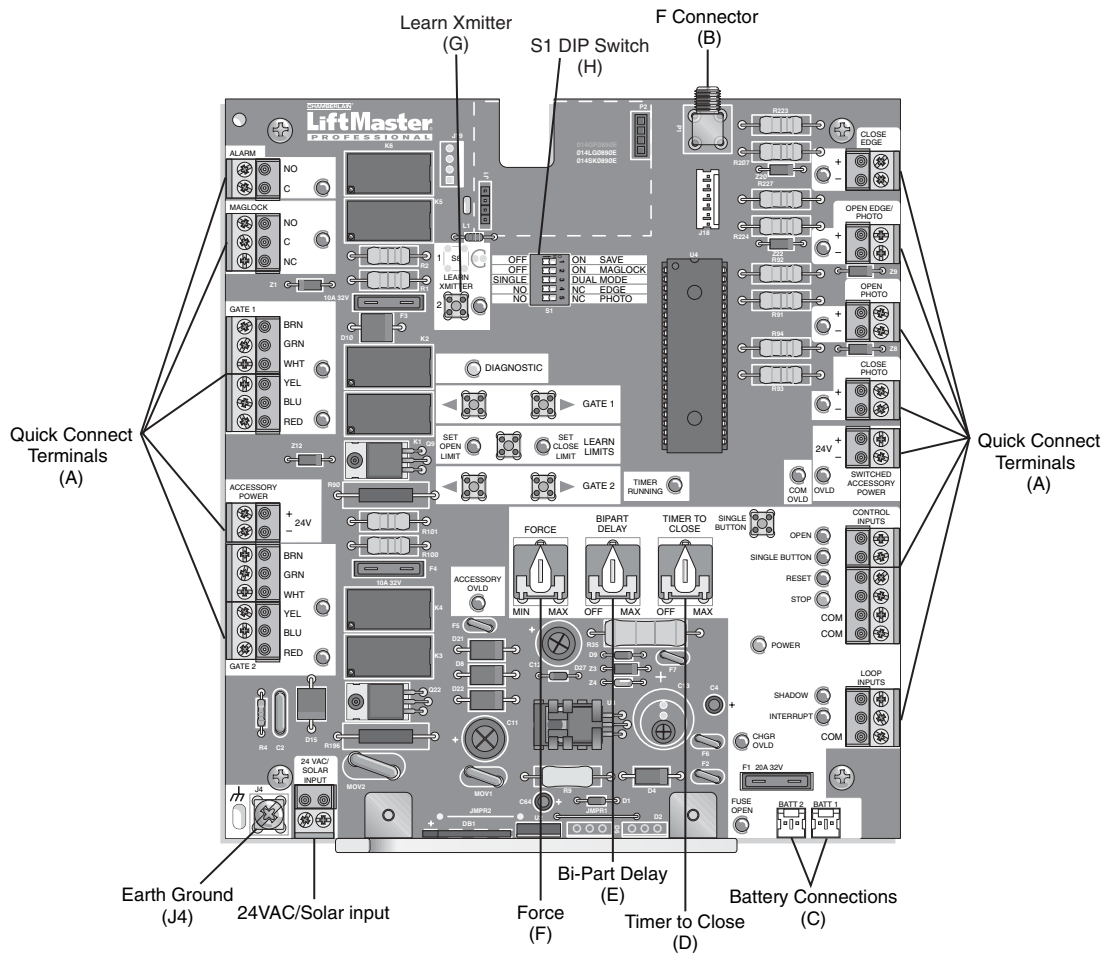

**INSTALL NEW BOARD (FIGURE 2)**

1. Remove the new board from the protective bag.
2. Copy all settings from the existing control board to the new board:
  - Force (F), Bi-Part Delay (E), and Timer to Close (D)
  - S1 DIP switch settings (H)
3. Install the new control board into the electrical box. Attach control board to mounting bracket with screws removed previously.
4. Reconnect the earth ground wire to the board connector (J4).
5. Reconnect the coaxial cable to the board F connector (B).
6. Reconnect all quick connect terminals (A) to the logic board.
  - Wiring terminals
  - Motor connectors
  - Alarms
  - Reset terminals

**NOTE:** The quick connect terminals (blue connectors) that have wires attached from the previous board can be reused.

7. Clear electrical box of all debris and tools.

**COMPLETE THE INSTALLATION**

**NOTE:** The following information is stored on the control board and will need to be reprogrammed after replacing the control board:

- All remote controls
- Saved DIP switch settings
- Limits

1. Reconnect power to the operator by first connecting the 24 VAC or solar power connector and then connecting the batteries. Verify that the POWER and STOP LEDs are on.
2. Toggle the SAVE DIP switch (ON to OFF and back to ON). This will save all DIP switch settings. Verify that all edge and eye LEDs are off. Verify that the DIAGNOSTIC LED is off.

**NOTE:** The RESET button may need to be pressed to clear any initial errors being displayed by the DIAGNOSTIC LED. If the LED does not turn off, use the error codes on page 7 to interpret the error and troubleshoot the problem.

3. Learn the limits for the gate operator (refer to detailed instructions below).
4. Cycle the operator to learn the force and to verify the operation of the gate operator.
5. Verify all other inputs and outputs as necessary (eyes, edges, loops, locks, alarm, reset, accessory power, open and single button).
6. Reprogram any remotes as necessary.
7. Make sure that the rubber seal around the cover is intact and close the cover. Insert screws (4) for control box cover. Verify that the rubber washer is in tact on each and tighten them to secure the cover.

## PROGRAM LIMITS

1. Turn Bi-Part switch to desired setting. Set to "Off" for single gate applications.
2. Press the "LEARN LIMITS" button.
3. The "SET OPEN LIMIT" LED will blink.
4. Use the "Gate 1" buttons to move Gate 1 to the desired open position. Repeat if Gate 2 is present using "Gate 2" buttons.
5. Press the "LEARN LIMITS" button to set the Open Limit for gate(s).
6. The "SET OPEN LIMIT" LED will turn off. The "SET CLOSE LIMIT" LED will blink.
7. Use the "Gate 1" buttons to move Gate 1 to the desired close position. Repeat if Gate 2 is present using "Gate 2" buttons.
8. Press the "LEARN LIMITS" button to set the close limit for gate(s).
9. The "SET CLOSE LIMIT" LED will turn off. The limits are set.
10. Using programmed remote or single button input (SBC) run the gate(s) from the close limit to the open limit. After reaching the open limit, run the gate(s) to the close limit. This will learn the force in the open and close direction.
11. If the learned force is not high enough, manually adjust the force control as described above.

**NOTE:** After final limit adjustments the gate can be opened slightly further by increasing the distance between center of gate hinge and the gate bracket by 1" (25 mm). Do not move the post bracket assembly.

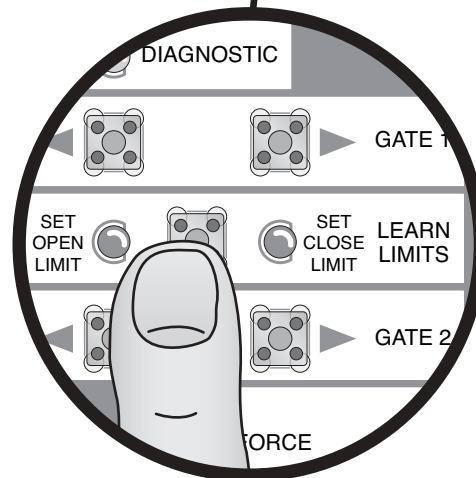
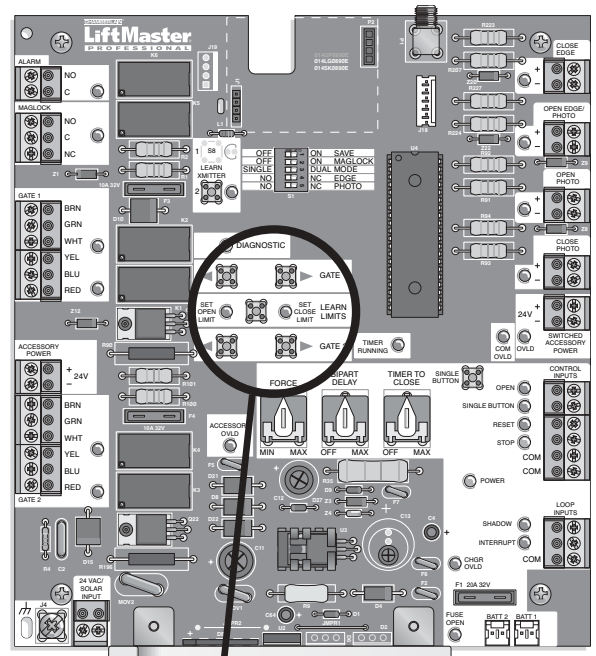

**NOTE:** Any following SBC or remote inputs will move the gate.

## PROGRAMMING REMOTE

1. Press LEARN XMITTER button (LED will light up).
2. Press remote button, the LED will flash, alarm output will activate twice.
3. Repeat steps 1 and 2 until all remotes are programmed (50 remotes maximum).

**NOTE:** For highest level of security, we recommend the Security+® line of products.

## COMPATIBLE REMOTES - 315MHz

Passport Remote	Security+® Remotes
CPT13	370LM
CPT23	371LM
CPT33	372LM
Security+® Keypad	373LM
376LM	374LM

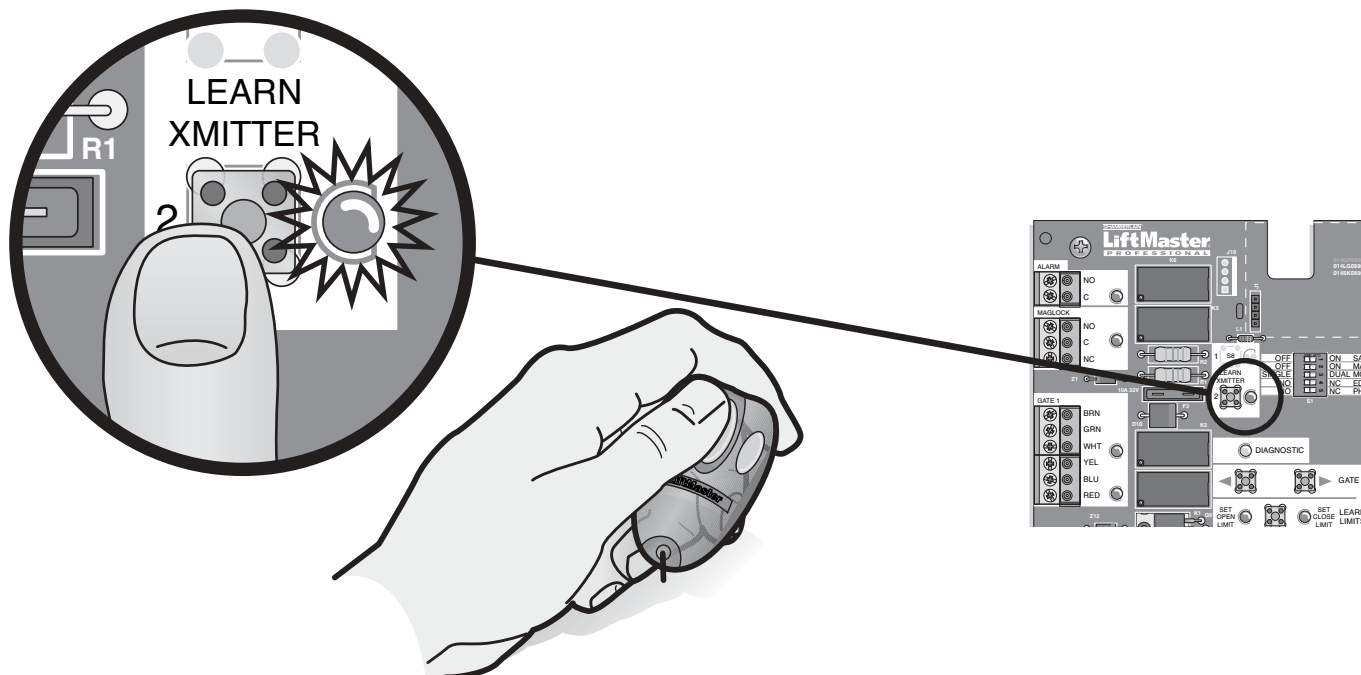

# TROUBLESHOOTING

FAULT	POSSIBLE CAUSE	FIX
<b>OPERATOR IS DEAD</b> When power is supplied to the control board, no LED turns ON.	1) Battery fuse is blown. 2) Battery or Run Transformer connection is loose. 3) Dead battery. 4) Bad control board.	➤ Replace battery fuse. Use only 20A, ATC style fuse. ➤ Check battery and transformer connections. ➤ Measure voltage across battery > 23V. ➤ Replace control board.
<b>OPERATOR DOES NOT RUN</b> Unit does not respond to a Radio command.	1) Low battery. 2) Radio (remote) not programmed. 3) STOP button connection loose. STOP LED is OFF. 4) There is an obstruction blocking photoelectric eyes in direction of movement. 5) Safety edge is damaged or on an obstruction. 6) Interrupt loop is obstructed. 7) Bad control board. 8) Motor fuse is blown.	➤ Measure voltage across battery > 23V. ➤ See Programming Remote section for programming instructions. ➤ Check STOP button connections (STOP and COM) to make sure they are secure. ➤ Check gate area to ensure photoelectric eyes are not blocked. ➤ Check gate area to ensure safety edge is not resting on an obstruction. Check safety edge wiring and connections. ➤ Check gate area to ensure path is unobstructed. ➤ Replace control board. ➤ Replace motor fuse. Use only 15A, ATC style fuse.
<b>OPERATOR DOES NOT RUN</b> Unit does not respond to SBC command.	1) Low battery. 2) SBC button connection loose. 3) STOP button connection loose. STOP LED is OFF. 4) Obstruction is blocking the photoelectric eyes in the direction of movement. 5) The safety edge is damaged or on an obstruction. 6) Interrupt loop is obstructed. 7) Bad control board. 8) Motor fuse is blown.	➤ Measure voltage across battery >23V. ➤ Check SBC and COM connections to ensure they are secure. ➤ Check STOP button connections (STOP and COM) to make sure they are secure. ➤ Check gate area to ensure photoelectric eyes are not blocked. ➤ Check gate area to ensure safety edge is not resting on an obstruction. ➤ Check safety edge wiring and connections. ➤ Check gate area to ensure path is unobstructed. ➤ Replace control board. ➤ Replace motor fuse. Use only 15A, ATC style fuse.
<b>MOTOR DOES NOT RUN</b> Relays 'click' when Radio or SBC signal is given, but the operator does not move.	1) Bad motor. 2) Cable wiring between control and operator arm disconnected or loose. 3) Bad control board. 4) Batteries not connected.	➤ Replace motor. ➤ Replace control board. ➤ Replace control board. ➤ Connect batteries.
<b>GATE STOPS AND REVERSES RIGHT AFTER IT STARTS MOVING</b>	1) A fault has occurred. 2) Force set too low.	➤ Check gate for obstructions. ➤ Adjust FORCE setting until gate completes a full open/close cycle without reversing. The force setting may need to be adjusted in cold weather, as the gate will not move as freely.
<b>GATE STOPS RUNNING RIGHT AFTER IT STARTS MOVING (BATTERY RUN)</b>	1) Battery voltage low or near low voltage cut-off. 2) A fault has occurred.	➤ Charge batteries. If problem persists, they may be near the end of their life. Replace batteries. <b>NOTE: Replace both batteries at the same time.</b> Use only Chamberlain part #K74-30762 for replacement batteries. ➤ Check gate for obstructions.
<b>GATE OPENS BUT DOES NOT CLOSE</b>	1) An input is continuously activated. 2) Entry system output is connected to the Open input, and is "stuck" opening.	➤ Verify that all inputs are functioning properly. ➤ Verify Entry system connections and operation.

# TROUBLESHOOTING

FAULT	POSSIBLE CAUSE	FIX
<b>GATE RUNS TOO SLOW</b>	1) Open and Close Limits are set too close together.  2) The gate is starting within the ramp down distance from the Open or Close Limit.	➤ If the Open and Close Limits are set within the ramp down distance of each other, the gate will run at slow speed all the time.  ➤ Gate will run slow to limits if motion is started within the ramp-down distance from the limit.
<b>GATE DOES NOT CLOSE AUTOMATICALLY</b>	1) Verify that the TTC is turned OFF. 2) Gate opened by an obstruction reversal. 3) The Interrupt Loop is obstructed. 4) Obstructed close photoelectric eye or edge. 5) The Open input is "stuck".	➤ Verify that the TTC is ON and set. ➤ Check gate area to ensure path is unobstructed.  ➤ Check the Open Loop area to ensure all obstructions are removed. If an external opening device or entry or entry system is attached, check for proper operation of that system.
<b>GATE WON'T STAY OPEN WHEN USING FIRE INPUT</b> Fire Input switch should be a constant contact key switch connected to Open Loop input (Open only).	1) Fire Input switch is a momentary contact.	➤ Make sure the Fire Input switch is constant contact. If it is not, replace with a constant contact switch.
<b>INTERRUPT LOOP DOES NOT ACT PROPERLY</b>	1) Bad loop sensor or loop detector.  2) Bad connection between loop sensor, loop detector, and the control board.	➤ Replace loop sensor or loop detector.  ➤ Check connections to make sure they are secure.
<b>EXIT LOOP (FREE EXIT) DOES NOT OPEN GATE</b>	1) Bad loop sensor or detector. 2) Bad connection between the loop sensor, loop detector, and the control board.  3) The Shadow Loop is obstructed. 4) An Open photoelectric eye or safety edge is obstructed.	➤ Replace loop sensor or loop detector. ➤ Check connections to make sure they are secure.  ➤ Check the gate area to make sure all obstructions are removed. ➤ Check the gate area to make sure all obstructions are removed.
<b>MAGLOCK DOES NOT WORK</b> Maglock does not hold gates locked	1) Bad connection between the Maglock, its power supply, and the control board. 2) Bad Maglock or Maglock power supply. 3) Large gap between gates. 4) Bad control board.	➤ Check connections between the Maglock, its power supply, and the control board to make sure they are secure. ➤ Replace Maglock or Maglock power supply. ➤ Reduce the gap between the gates. ➤ Replace the control board.

## DIAGNOSTIC CODES

# OF BLINKS	MEANING
1	No Stop Switch Connected
2	Gate 1 Arm Disengaged
3	Gate 2 Arm Disengaged
4	Both Gate Arms Disengaged
5	RPM Reversal
6	Force Reversal
7	Processor Reset
8	ROM Check Failed
9	RAM Check Failed
10	EEPROM Check Failed