

INTRODUCTION

The following procedure replaces the LA500 arm trolley nut, should it become damaged by a car strike to the gate or other similar event. This procedure is intended to be performed in a clean shop by personnel confident in performing such procedures.

Most of the LA500's internal drive train parts are factory assembled under tight tolerances. Should any of these parts lose alignment, reliable performance will be impacted. This procedure's performance may impact the arm warranty coverage; therefore, if the subject arm is still covered under product warranty, please consider replacing the arm instead of performing this procedure. Retain all hardware; it will be needed for reassembly.

TOOLS NEEDED

- LA500 control box with photoelectric sensors
- Torque screwdrivers
- Metric Allen wrench
- 12V, 7A battery
- Flathead and Phillips head screwdrivers
- Fastener (E-ring) pliers
- Needle nose pliers

CARTON INVENTORY

Description	QTY
Trolley nut	1

ADDITIONAL PARTS INCLUDED

The following items are provided for additional damage that occurred when the trolley nut was broken, or for parts that may have become lost in the performance of this procedure.

Description	QTY
Pan Head Screw, M5	2
Split Washer, M6	3
Pan Head Screw, M6	1
Nut, M6	3
O-ring	1
Pin	1
Retaining Ring	1
Retaining Ring	1
Bearing	1
Trolley Plate	2
Bushing Retainer	1
Flat Washer, M6	2
Screw M6	2
Trolley Pin	1
Base plate	1
Arm Gasket	1
Screw, M5	12

⚠ WARNING

To reduce the risk of INJURY or DEATH:

- DISCONNECT power and battery BEFORE installing or servicing operator.
- See manual regarding maintenance and required safety testing prior to servicing.



WARNING: This product can expose you to chemicals including lead, which are known to the State of California to cause cancer or birth defects or other reproductive harm. For more information go to www.P65Warnings.ca.gov.

INSTALLATION

OPEN THE ARM

1. Invert the arm to gain access to the top cover screws.
2. Remove the 12 top cover screws using a T25 torque screwdriver or wrench.
3. Turn the arm back to normal operating orientation.
4. Carefully separate the top cover from the rest of the arm. Note that the post bracket might fall out.
5. Place the top cover in a safe, clean location. Make sure that the arm gasket does not get contaminated.

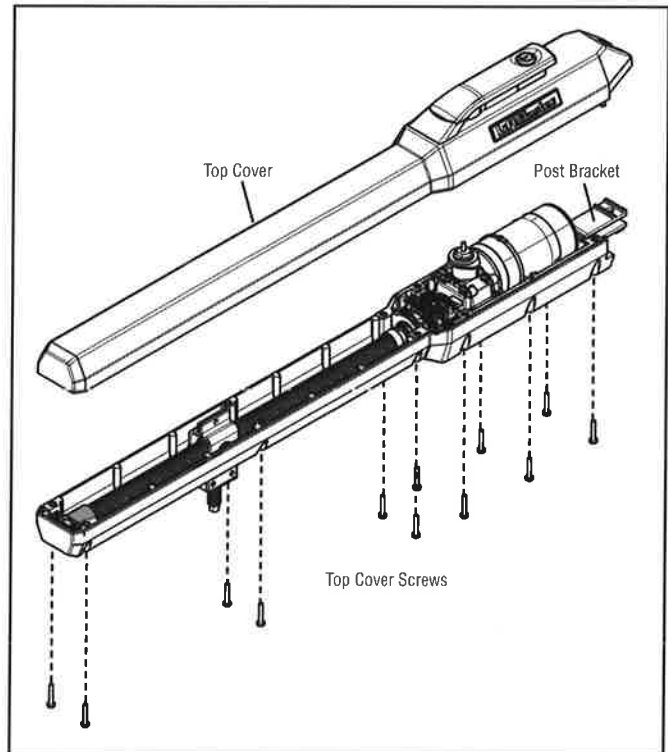

REMOVE THE LED CIRCUIT CARD

1. Unplug the J1 plug from the connector.
2. Remove the two LED circuit card mounting screws using a T10 screwdriver or wrench.
3. Set the LED circuit card and mounting hardware aside in a clean location.

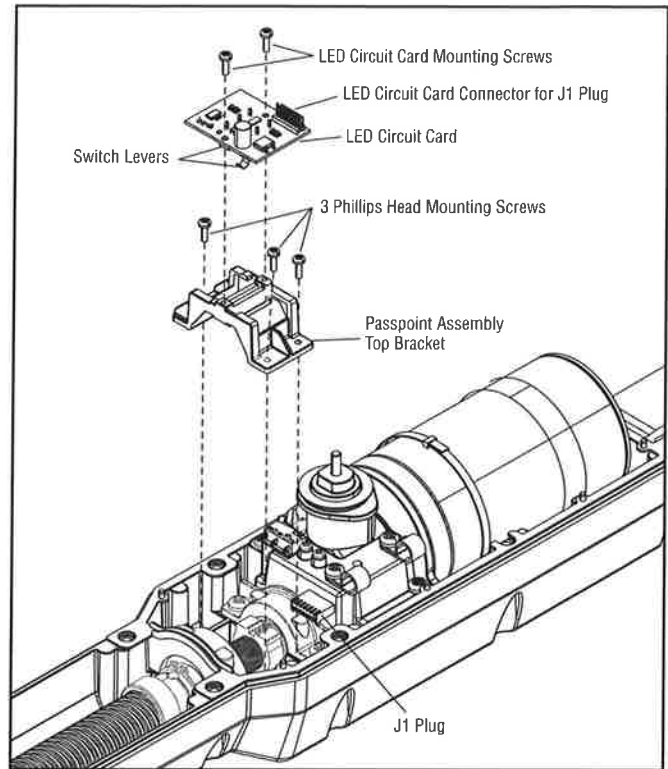

REMOVE THE PASSPOINT ASSEMBLY TOP BRACKET

1. Remove the three Phillips head mounting screws that secure the Passpoint assembly top bracket.
2. Lift the Passpoint assembly top bracket from the arm assembly and set aside in a clean location, along with the mounting hardware.

SLIDE RETAINING RING BACK, AND REMOVE THE TROLLEY PIN

1. Press the bypass release lever to permit the rotation of the drive screw.
2. Rotate the travel assembly to gain access to the free ends of the retaining ring.
3. Using a set of fastener (E-ring) pliers, slide the retaining ring towards the motor to gain access to the trolley pin that it secures into place.
4. Using a small Phillips head screwdriver, press the trolley pin approximately 1/4 of the way through the hole.
5. Press the bypass release lever, and rotate the drive screw 180 degrees.
6. Using needle nose pliers, remove the trolley pin and set it aside into a clean location. (Drive screw can now be turned without using the bypass release lever).

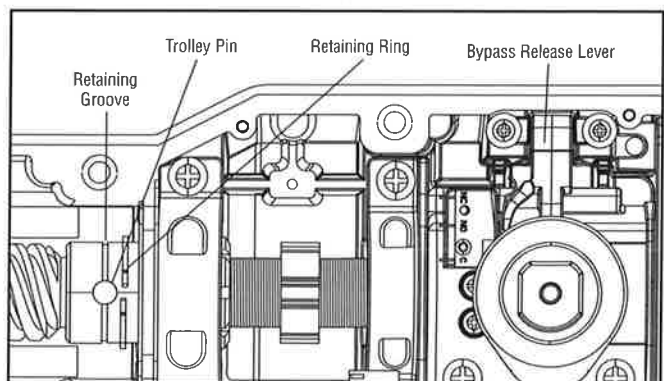
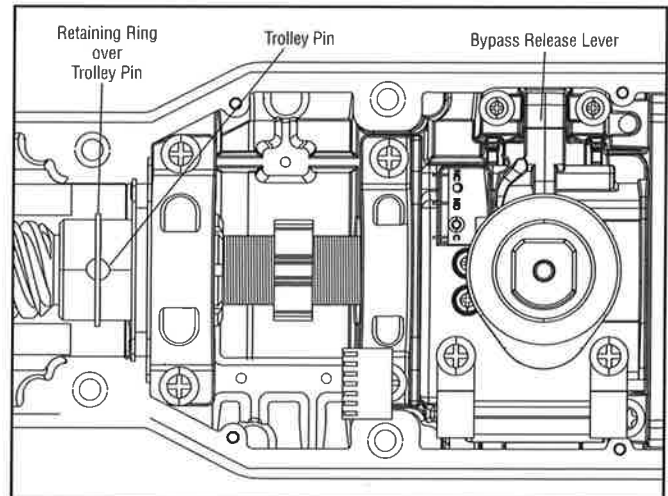

LOOSEN BEARING COVER SCREWS

1. Locate the four bearing cover screws that secure the Passpoint assembly onto the arm.
2. Loosen the bearing cover screws by turning them three times counterclockwise.

WARNING

- Do not remove these screws.
- Do not loosen any other drive train flange screws.
- Removing these parts will require that the arm be entirely replaced.

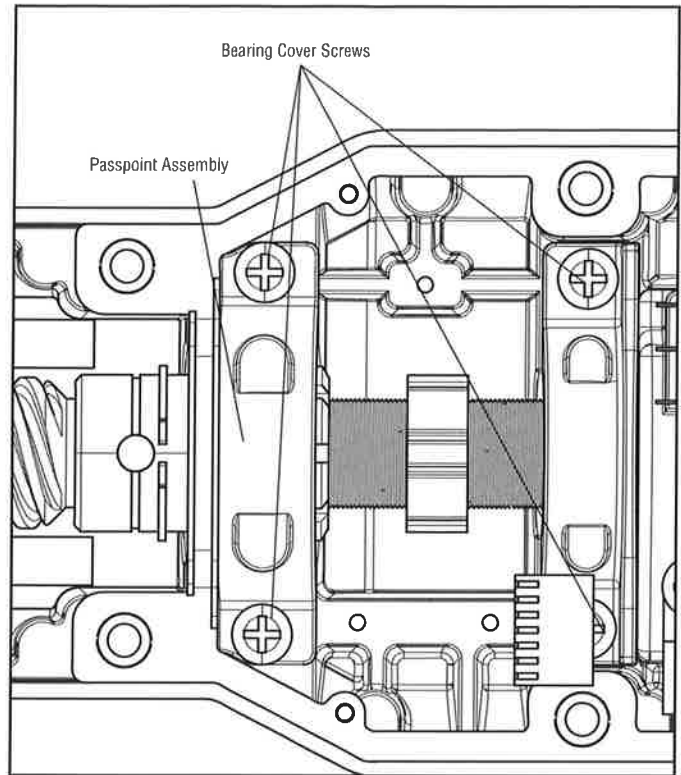

REMOVE THE BUSHING RETAINER FROM THE ARM NOSE

1. Using a wide flathead screwdriver or T25 torque wrench, remove the two bushing retainer mounting screws that secure the bushing retainer to the arm.
2. Remove the bushing retainer and place in a clean location with the corresponding screws.

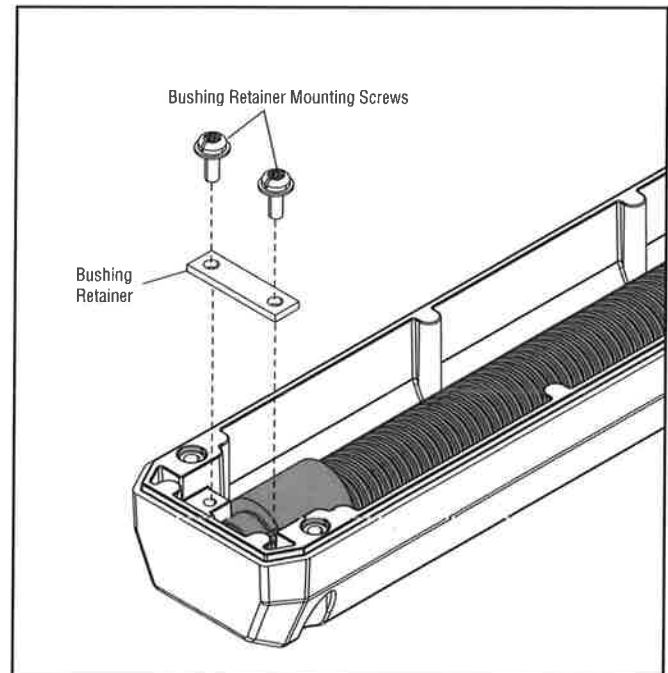

REMOVE THE BASE PLATE

1. Gain access to the bottom of the arm.
2. Using the appropriate wrenches, remove the two nuts from the bolts that secure the base plate to the two trolley plates.
3. Note the order of the flat and split washers on the two bolts.
4. Remove the washers, nuts and bolts from the trolley plates using two 10 mm wrenches.
5. Remove the base plate from the trolley plates.
6. Place the bolts, nuts, washers, and base plate in a clean location.

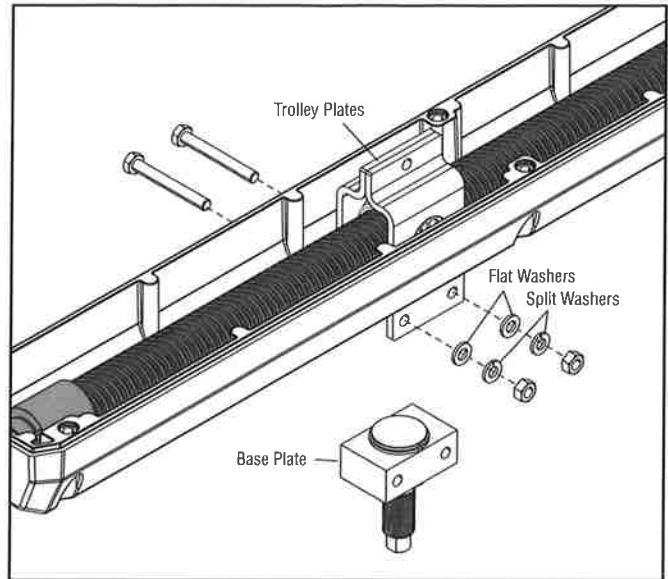

REMOVE THE BOLT, NUT AND WASHER THAT PINCHES THE TWO TROLLEY PLATES TOGETHER

1. Gain access to the top of the arm.
2. Using a number 5 Allen wrench and 10 mm wrench, remove the bolt, washer, nut and trolley plates from around the trolley nut, and place in a clean location for later use.

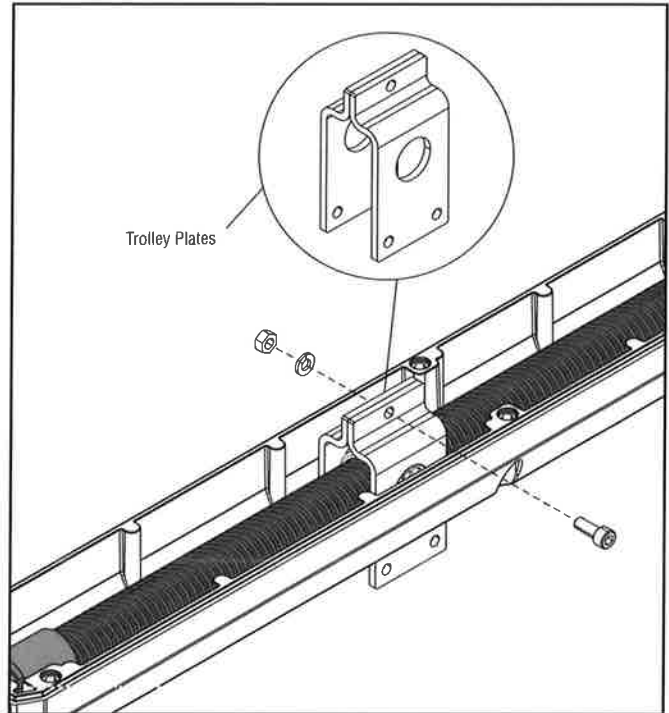

REMOVE THE DRIVE SCREW FROM THE ARM

1. There is a long plastic cap and a bearing on the nose side of the drive screw, and a short plastic cap on the Passport assembly side of the drive screw. These items can fall from the drive screw as it is lifted from the arm. Note their orientation before removal, so that they are reassembled correctly in a later step.
2. Remove the drive screw from the arm, starting at its nose side. It may take some back and forth rocking action to wiggle the drive screw from the collar at the Passport assembly.
3. Remove the bearing and end caps from the drive screw and set aside.

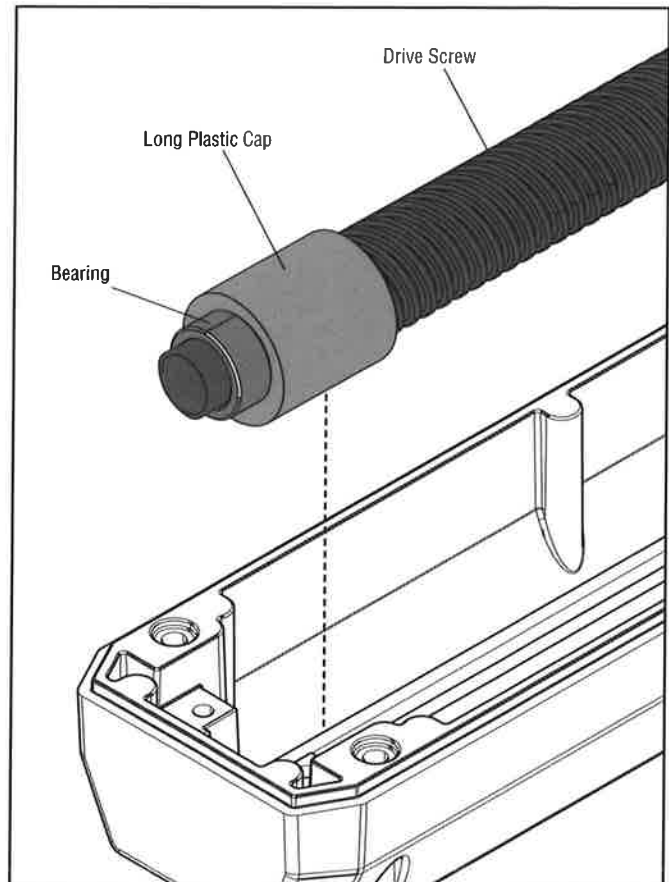
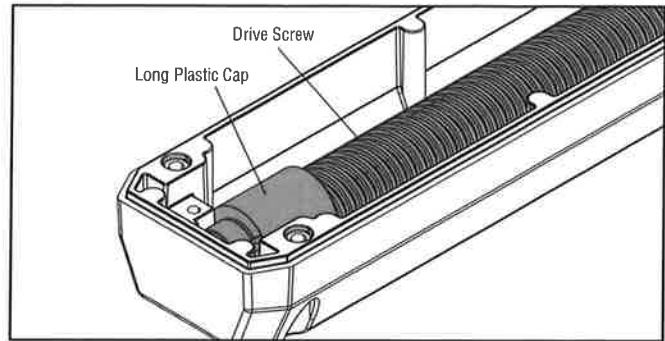

REPLACE THE BROKEN TROLLEY NUT ON DRIVE SCREW

1. If the trolley nut hasn't already fallen free of the drive screw, unscrew the damaged part from the drive screw.
2. Screw the replacement trolley nut from the service kit onto the drive screw positioning it at the middle, and set aside in a clean location.

NOTE: It is important that the trolley nut be placed in the center of the drive screw for later use. This can be verified with measurements using a tape measure.

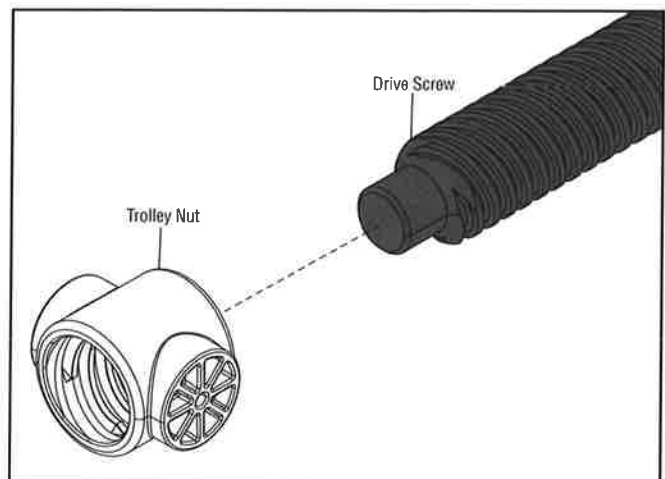

CENTER THE PASSPOINT NUT

NOTE: This LA500 arm system is powered by a 24 Vdc motor, but the motor will run on a 12 Vdc battery at a slower motion and rate for easier operation of the following steps.

1. Using a 12V battery, move the Passpoint nut to the center of the Passpoint assembly.
 - a. Touch the blue and red wires from the arm connector cable to the positive (+) and negative (-) terminals of the battery.
 - b. To spin in the opposite direction, change the polarity of the blue and red wires to the battery.
2. Use calipers or a scale to measure the distance of each side of the Passpoint nut to the housing to get as close as possible to center.

WARNING

Proceeding along this installation without centering the Passpoint nut can cause the nut to impact against the sides of the travel area and can damage the Passpoint nut. If the Passpoint nut is damaged in this procedure, the arm will need to be replaced.

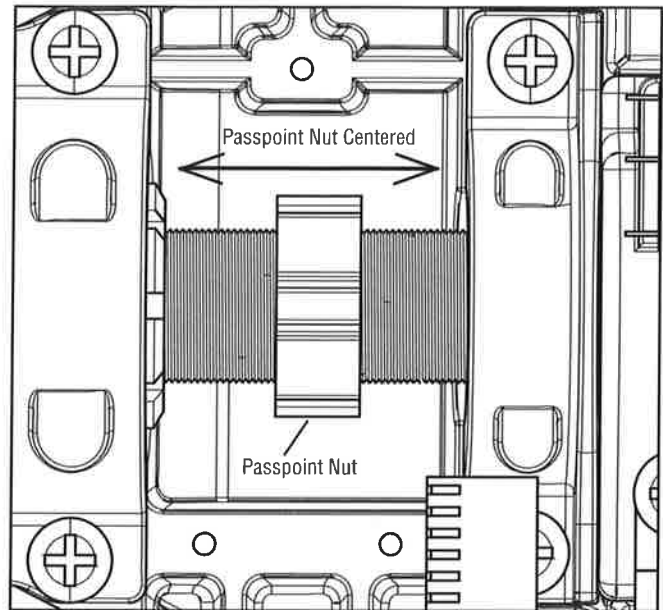

REPLACE THE TWO PLASTIC CAPS AND BEARING FROM THE DRIVE SCREW

1. Replace the bearing and the long plastic cap on the nose side of the drive screw.
2. Do not replace the short plastic cap on the motor side of the drive screw at this time.
3. Stand the arm with the nose side pointed up.
4. Look inside of the collar on the Passport assembly and verify that an O-ring is present. If not, obtain the O-ring from the kit and place within the collar.
5. Place the drive screw over the collar.
 - a. Place the short plastic cap side of the drive screw into the collar.
 - b. Carefully work the drive screw into the collar, rocking it back and forth until it slides into the collar.
 - c. Once the short plastic cap side of the drive screw slips into the collar, rest the bearing and long plastic cap side of the drive screw onto the groove at the nose of the arm.

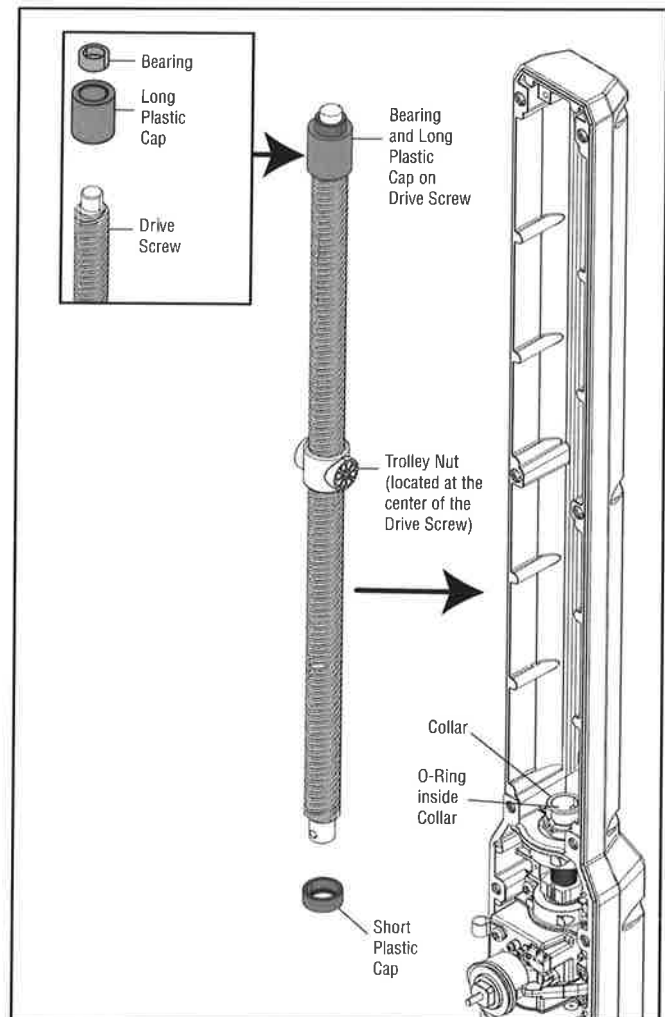

REPLACE THE BUSHING RETAINER TO THE NOSE OF THE ARM

1. Replace the bushing retainer over the bearing of the drive screw.
2. Secure the bushing retainer using a wide flathead screwdriver or T25 torque wrench and the two bushing retainer mounting screws.

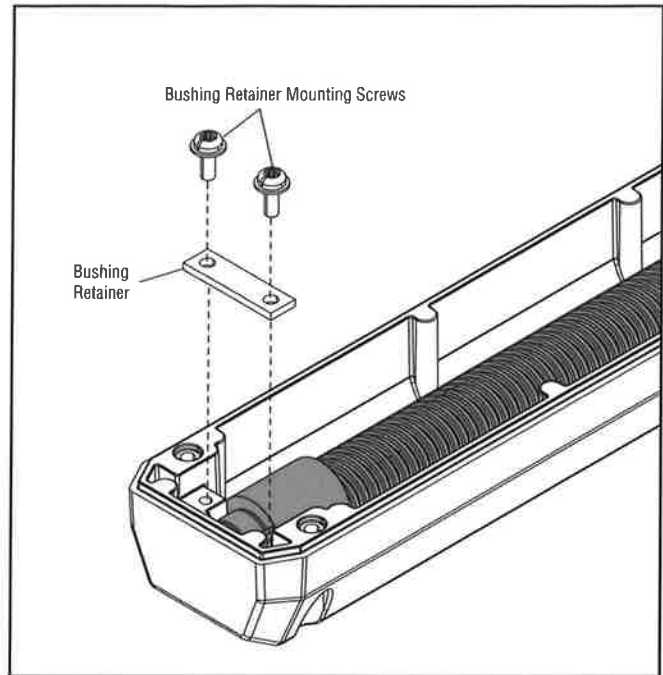

CENTER THE TROLLEY NUT

NOTE: It is critical to make sure that the trolley nut is placed in the center of the drive screw.

1. Use a tape measure to make sure the trolley nut is located center on the drive screw.
2. To reassemble the travel assembly over the trolley nut, it might be helpful to move the trolley nut above or below the cover screw hole standoffs, but it must be re-centered prior to inserting the travel assembly back through the collar and drive screw.

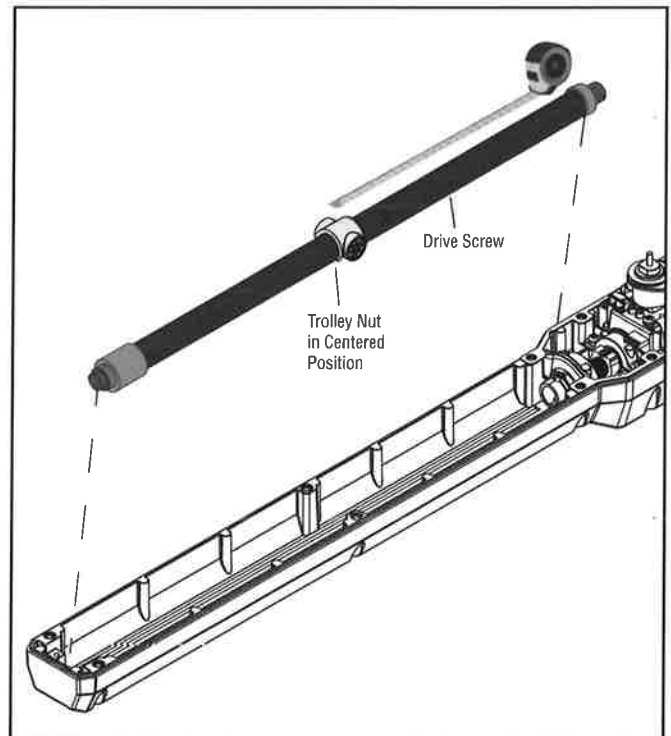

RE-ASSEMBLE THE BASE PLATE TO THE ARM

1. Place the two trolley plates into the arm surrounding the trolley nut, ensuring that the guide for the brackets meet up with the clear holes on the brackets that are designed to receive them.
2. Tighten the #5 Allen screw to the top of the brackets to clamp the brackets around the drive screw.
3. Gain access to the bottom of the arm.
4. Insert the base plate between the two trolley plates and secure them with the mounting hardware, paying attention to the order of the washers and nuts.

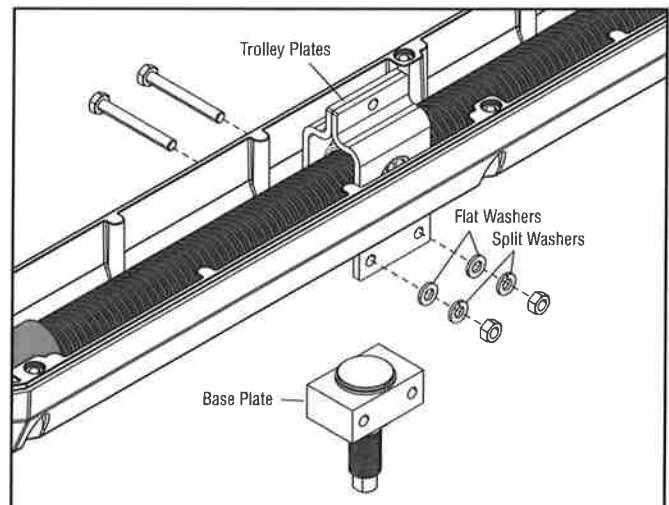
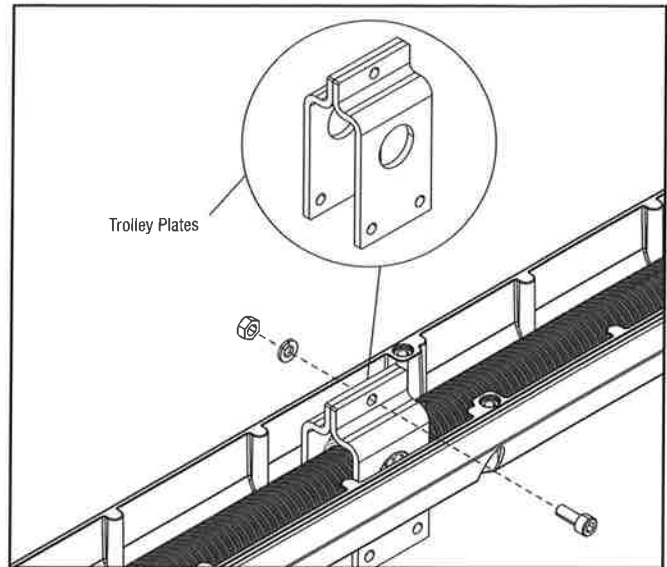

MANUALLY RETURN THE TRAVEL ASSEMBLY TO CENTER OF THE DRIVE SCREW

1. Using a tape measure, ensure that the travel assembly is located at the center of the drive screw. The drive screw can be turned by hand at this time.
2. Once the travel assembly is centered, and the Passpoint nut is centered, the trolley pin can be placed through the collar.

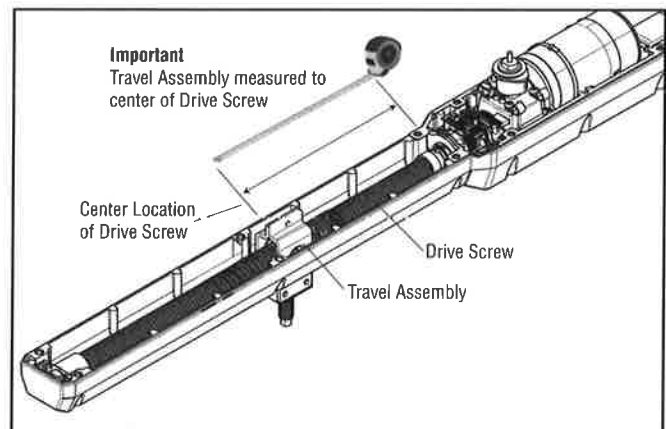

REPLACE THE TROLLEY PIN

1. Align the holes for the drive screw and the collar from the Passpoint assembly.
2. Insert the trolley pin back into the hole.
3. Return the retaining ring to the retaining groove. Make sure that the circumference of the retaining ring covers the trolley pin, instead of the gap between the retaining ring's free ends.
4. The drive screw can no longer be turned by hand.

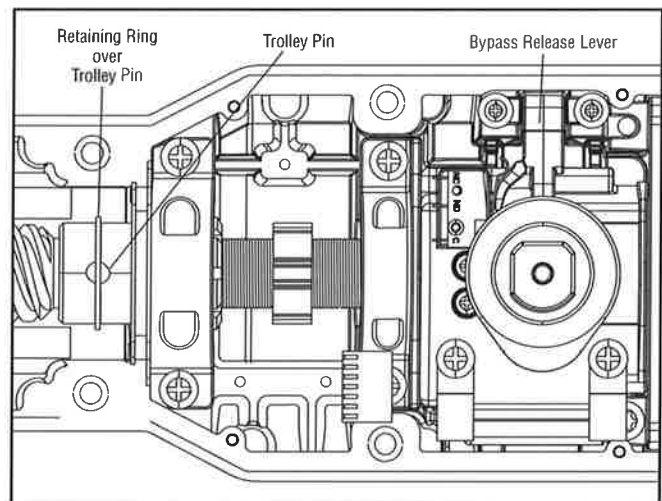
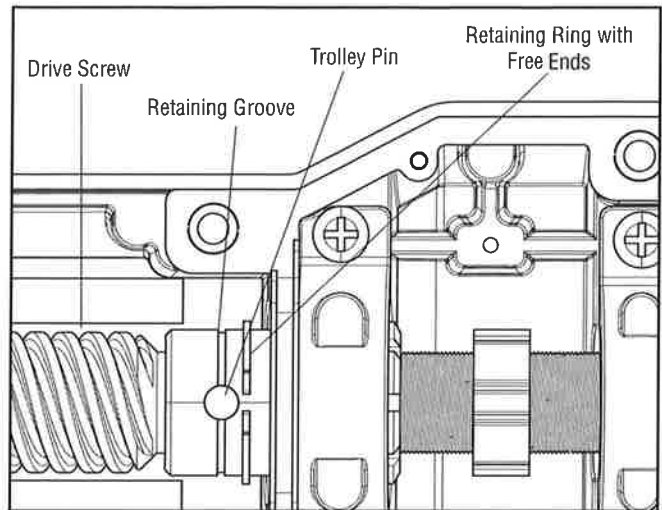

TIGHTEN THE BEARING COVER SCREWS

1. Re-tighten the four bearing cover screws by turning them three times clockwise until snug.

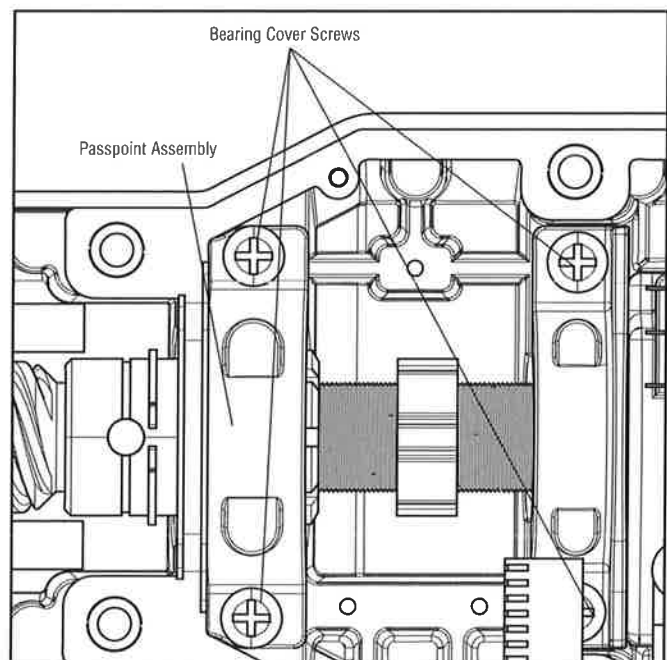

TEST THE CLEARANCE OF THE PASSPOINT NUT AT TROLLEY NUT LIMITS

1. Using battery, manually move the trolley nut to the outer limit while observing the Passpoint nut. Make sure that the Passpoint nut does not interfere with the arm housing when the trolley nut reaches the end of travel in the open direction. A clearance of 1/8 inch is desired.
2. Using battery, manually move the trolley nut to the inner limit while observing the Passpoint nut. Make sure that the Passpoint nut does not interfere with the arm housing when the trolley nut reaches the end of travel in the close direction. A clearance of 1/8 inch is desired.
3. Reposition the travel assembly to center.

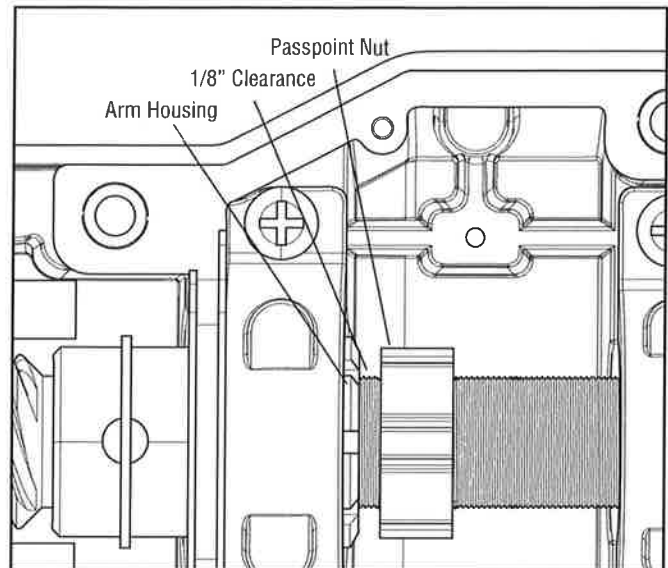
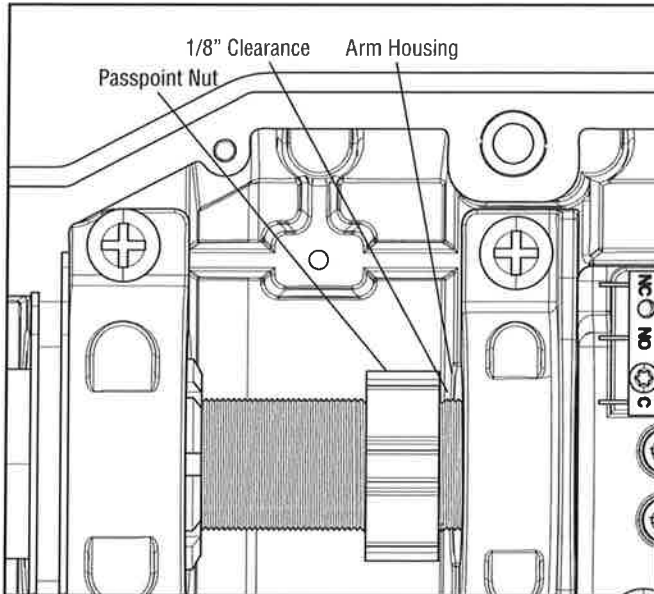

Passpoint nut position when trolley nut is moved to the outer limit

Passpoint nut position when trolley nut is moved to the inner limit

REPLACE THE PASSPOINT ASSEMBLY TOP BRACKET

1. Place the Passpoint assembly top bracket over the Passpoint nut making sure that the guide of the bracket fits into the groove of the Passpoint nut.
2. Secure the Passpoint assembly top bracket with the three Phillips head mounting screws and washers.

REPLACE THE LED CIRCUIT CARD

1. Inspect the bottom of the LED circuit card and ensure that both of the switch levers are on the micro-switches mounted on the bottom of the board, and that they are not damaged or distorted.
2. Replace the LED circuit card so that the LED circuit card connector is close to the J1 plug.
3. Tighten the two LED circuit card mounting screws securing the LED circuit card to the Passpoint assembly top bracket.
4. Plug in the J1 plug to the LED circuit card connector.

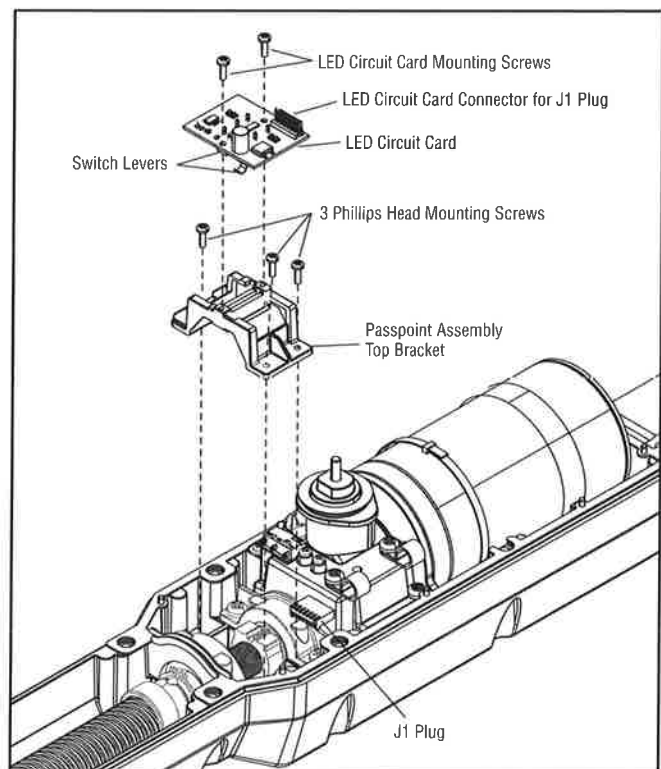

PRE-COVER CHECKLIST

1. Is the travel assembly centered?
2. Is the Passpoint assembly centered?
3. Are the four bearing cover screws securing the Passpoint assembly tightened?
4. Is the LED circuit card plugged in?
5. Is the retaining ring covering the trolley pin?
6. Is the bushing retainer assembled?

ASSEMBLE THE TOP COVER

1. Inspect the washer around the motor housing, looking for creases, tears or folds. Correct or replace as needed.
2. Make sure that the post bracket is located at the rear of the arm.
3. Replace the top cover of the arm, and insert and tighten the 12 top cover screws.

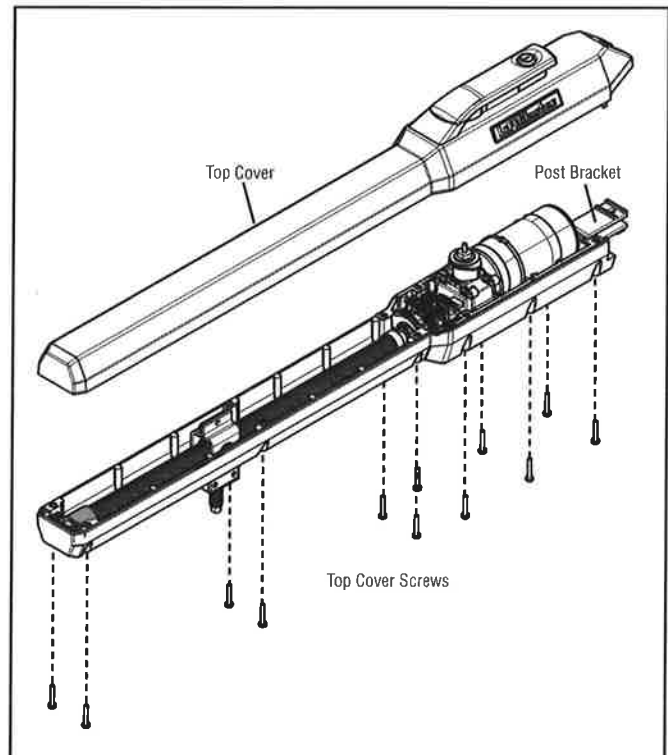

TEST

NOTE: Refer to the Model LA500 operator manual for programming or installation instructions.

Bench test the arm.

1. Connect the arm into an LA500 control box for testing.
 - a. Wire the cables from the arm to the arm one connector of the LED circuit card in the LA500, following the wire colors listed on the board and shown on the connector.
 - b. If the model of the ebox requires entrapment protection, connect a set of photoelectric sensors to the board to the close eyes input, and align the photoelectric sensors on the bench top.
 - c. Place timer to close in the OFF position (fully counterclockwise).
 - d. Place the reversal force setting to 1 o'clock.
 - e. Disconnect the expansion board.
2. Learn arm limits.
 - a. Clear previous limits from the board by pressing and holding the set open and set close buttons simultaneously until the operator beeps. Both the set open and set close LEDs should be flashing.
 - b. Place the gate toggle switch into the arm1 position.
 - c. Using the move gate buttons, move the travel assembly to the outer limit of the arm. Press set close.
 - d. Using the move gate buttons, move the travel assembly to the inter limit of the arm. Press set open.
 - e. Make sure that both the set open and set close buttons are extinguished.
 - f. If the arm fails to set limits, or presents an error code during this operation, there is either a problem with the assembly of the arm, or an additional failure within the arm.
3. Perform a complete open and close cycle to the arm, making sure that no unusual noise is heard, and that the trolley smoothly moves from open to close limits and vice versa.
 - a. Press the close button.
 - The travel assembly should move towards the outer limit.
 - The blue LEDs on the arm top should illuminate.
 - b. Press the open button.
 - The travel assembly should move towards the inter limit.
 - The blue LEDs on the arm top should illuminate.
 - c. Listen to the trolley in motion to ensure that there are no interference or nuisance noises from the arm while the travel assembly is in motion.
 - d. The blue LEDs on the arm top should illuminate.
4. If the arm passes these steps, it is ready for field placement.

HOW TO ORDER REPAIR PARTS

DEVANCO CANADA

19192 HAY ROAD, UNIT Q
SUMMERSTOWN, ON K0C 2E0

TOLL FREE: 855-931-3334

www.devancocanada.com

**WHEN ORDERING REPAIR PARTS
PLEASE SUPPLY THE
FOLLOWING INFORMATION:**

- ✓ PART NUMBER
- ✓ DESCRIPTION
- ✓ MODEL NUMBER