



GM
South
Africa

P&A Marketing - Accessories -

After-market Accessory Fitment Instruction

Product	Chevrolet Utility styling bar	NOTE: For exclusive use by the GM Dealer Network - fitments to be performed by qualified technicians.
Part Number	1600070	
Vendor(Code)		
Applicable Vehicle Platform	Chevrolet Utility Base model + Sports model	 60 min

Kit Content:

Qty.	Description	Qty.	Description	Qty.	Description
2	M10x25 set screws	4	ø5x35mm pan posi machine screws		
2	M10 Spring washers	4	M5 Spring washers		
2	M10 Flat washers	4	M5 Flat washers		
4	ø4.2x25mm pan posi self tapping screws				
4	M4 Flat washers				

Additional Equipment/Material Required for Fitment:

Qty.	Description	Qty.	Description	Qty.	Description
1	Socket and Ratchet set	1	Small flat screw driver		
1	Star screw driver	1	Set Spline keys		
1	Set allen Keys				

Precautions

Fitment Precautions:

1. Avoid direct contact with sharp objects when removing the packaging.
2. At least two people are needed for this fitment.

Directions for Use:

1. Have the bar placed on a rubber mat to avoid any damage during fitment



GM
South
Africa

P&A Marketing
- Accessories -

Fitment Instruction:

Styling bar

Model

Registered No.:

Chevrolet Utility



Accessory Class:

Page...2...of...6...

Date 05.05.17

Visual/Graphic Illustration

Step

Step Description

Method

Equipment Required



Styling bar
Passenger's Side



Styling bar
Driver's Side



Mount Plat
Passenger's Side



Mount Plat
Driver's Side

ø4.2x25mm pan posi self tapping
screws x 4



M4 flat washers x4



ø5x35mm pan posi machine
screws x 4



M5 flat washers x4



M5 spring washers x4



M10 x 25 set screws x2



M10 flat washers x2



M10 spring washers x2



Check kit contents as
shown in the image.

Provided in Pack:
Fitment instructions

Provided By User:

Component Supplier:

Artav Stainless Steel

Part

No./Reference

GMSA P&A Development Co-ordinator:

Date:

GMSA Engineering Approval:

Date:

GMSA P&A Business-line Manager

Date:



GM
South
Africa

P&A Marketing
- Accessories -

Fitment Instruction:

Styling bar

Model

Registered No.:

Chevrolet Utility



Accessory Class:

Page...3...of...6...

Date 05.05.17

Visual/Graphic Illustration

Step #

Step Description

Method

Equipment Required

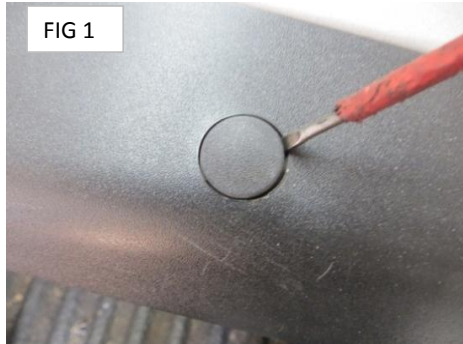

FIG 1



FIG 2

1

Remove 4 off Top Screw Caps.

Using the small flat screw driver remove the small plastic caps to expose the screws holding the main cover in place (Fig1). (FIG 2) shows which caps to remove. Once the caps are removed, you will also be required to remove the screws.

Provided in Pack:

Provided By User:
Small flat screw driver
Set Spline Keys

Component Supplier:

Artav Stainless Steel

Part

No./Reference

GMSA P&A Development Co-ordinator:

Date:

GMSA Engineering Approval:

Date:

GMSA P&A Business-line Manager

Date:



GM
South
Africa

P&A Marketing
- Accessories -

Fitment Instruction:

Styling bar

Model

Registered No.:

Chevrolet Utility



Accessory Class:

Page...4...of...6...

Date 05.05.17

Visual/Graphic Illustration

Step #

Step Description

Method

Equipment Required

To be done on middle tie down only.

FIG 3

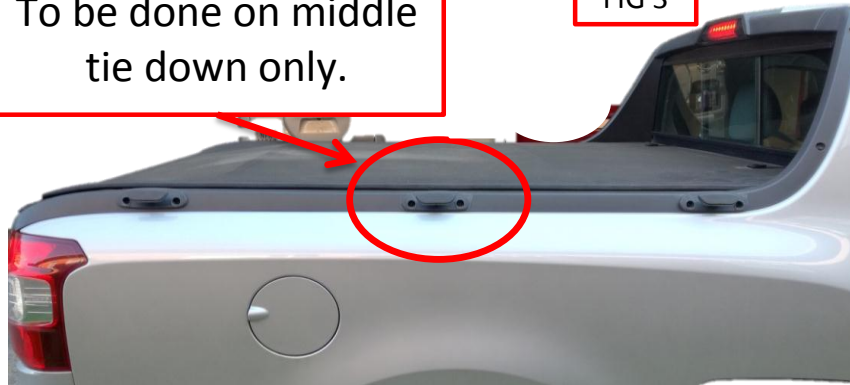

2

Removal and Replacement of Tie Down Screws.

Replace all the standard screws in the middle tie down with the ones from the kit as seen in fig 3. Do not tighten fully, leave enough gap to fit the mounting plates in the next step.

Provided in Pack:
ø5x35mm pan posi machine screws x 4
M5 Spring washers x 4
M5 Flat washers x 4

FIG 4

Marking (PS) for Passenger Side

PS

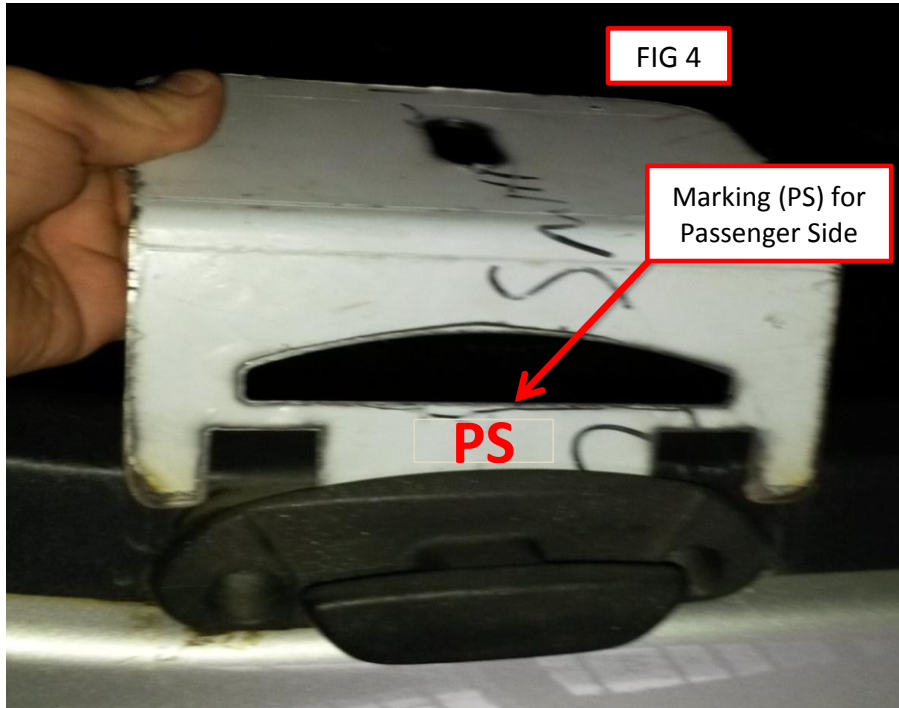

3

Placement of mounting brackets.

Sandwich the mounting plate between the Tie Down Hook and the edge of the bin, Do not fully tighten.

Do to both sides of the vehicle.

Provided By User:
Set Spline keys
Star Screw Driver

Component Supplier:

Artav Stainless Steel

Part

No./Reference

GMSA P&A Development Co-ordinator:

Date:

GMSA Engineering Approval:

Date:

GMSA P&A Business-line Manager

Date:



GM
South
Africa

P&A Marketing
- Accessories -

Fitment Instruction:

Styling bar

Model

Registered No.:

Chevrolet Utility



Accessory Class:

Page...5...of...6...

Date 05.05.17

Visual/Graphic Illustration

Step #

Step Description

Method

Equipment Required

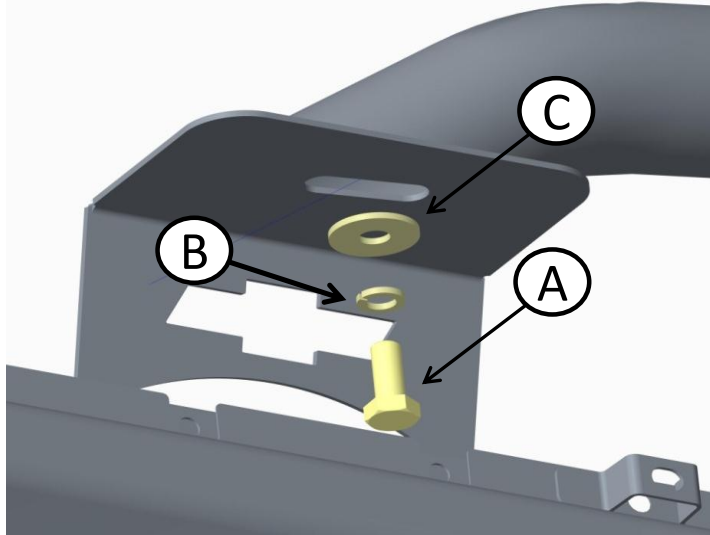

FIG 5

4

Mount sports bar to
Mounting plate.

Mount the sports bar to the
Mounting plate as shown in
Fig.5.

Provided in Pack:
(A) M10x25 set screws x 2
(B) M10 Spring washer x 2
(C) M10 Flat washer x 2
(D) ø4.2 x 25mm Pan posi
self tapping Screws x 4
(E) M4 Flat washers x 4

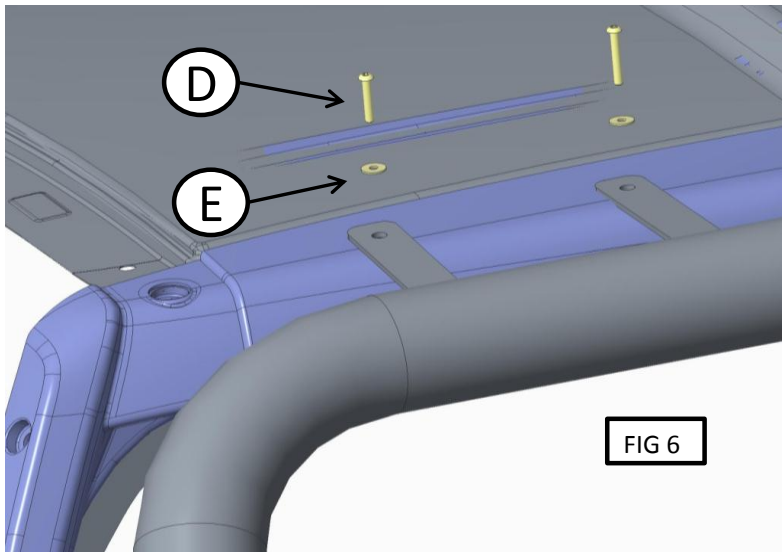

FIG 6

5

Mount top screws.

Mount the top of the sports bar
to the holes to where
the Caps were removed
from step 1. FIG 6 shows
what kit to use.

Do to both
sides of the
vehicle.

Provided By User:
Socket and Ratchet set.
No. 17 Socket
Screw driver (star)

Component Supplier:

Artav Stainless Steel

Part

No./Reference

GMSA P&A Development Co-ordinator:

Date:

GMSA Engineering Approval:

Date:

GMSA P&A Business-line Manager

Date:

 GM South Africa	P&A Marketing - Accessories -	Fitment Instruction: Styling bar	Model	Registered No.:	 Page...6...of...6... Date 05.05.17
			Chevrolet Utility		
			Accessory Class:		

Final Views as Fitted



Comments:	Comments:	Comments:
	<p style="color: red;">Ensure the styling bar is aligned and that all the fasteners are tightened.</p>	

	Component Supplier:	Part No./Reference	
	Artav Stainless Steel		Date:
	GMSA P&A Development Co-ordinator:		Date:
	GMSA Engineering Approval:		Date:
	GMSA P&A Business-line Manager		Date: 