

ACCESSORY FITMENT

Product

Ford ranger(facelift) nudge bar

Part No.

150045T, 150041T,BS-150041
150042T, BS-150042 (TN:56)



60
Minutes

Models : All except with PDC sensors in front

Page 1 of 9

03/11/2015

DIAGRAM

Kit content:

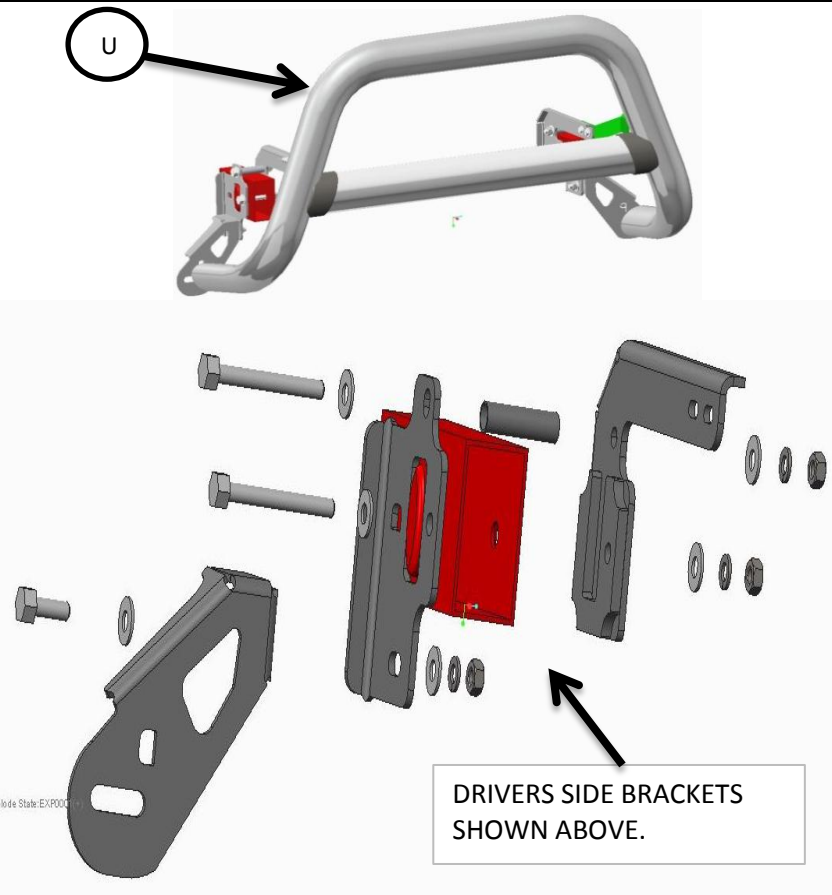

	Qty	Description		Qty	Description
A	4	M10 X 90 SETS	L	4	M8 HEX NUTS
B	6	M10 HEX NUTS	M	8	M8 FLAT WASHERS
C	4	M10 X 30 SETS	N	4	M8 SPRING WASHERS
D	2	M10 X 40 X 3 FLAT WASHERS	O	2	DS AND PS BOTTOM BRACKET
E	8	M10 SPRING WASHERS	P	2	DS AND PS SIDE PLATE
F	12	M10 X 30 X 2.5 FLAT WASHERS	Q	2	DS AND PS MOUNTING BRACKET
G	4	M8 X 20 X 1.6 SS FLAT WASHERS	R	2	DS AND PS INTERMEDIATE BRACKET
H	2	M8 SS HEX NUTS	S	2	TUBE SPACER 60MM LONG
I	2	M8 SS SPRING WASHERS	T	1	STICKER
J	2	M8 X 25 SS BUTTON HEADS	U	1	NUDGE BAR
K	4	M8 X 25 SETS			

Additional equipment/Material needed for fitment :

Qty		Qty	
	SOCKET SET		STANLEY KNIFE
	TORQUE WRENCH		RULER/MEASURING TAPE
	5MM ALLEN KEY		
	SMALL FLAT SCREW DRIVER		

Precautions during fitment:

Ensure you have a safe dedicated spot to place bumper when removed from vehicle. You will require 2 people for fitment.

Fitment Instruction: Ford Ranger Nudge

Visual / Graphic Illustration	Step #	Description/Method
	1	Remove the Bumper from the vehicle(Fig 1), keep all clips in a separate container. Note that Grill and air deflectors come off with the Bumper.

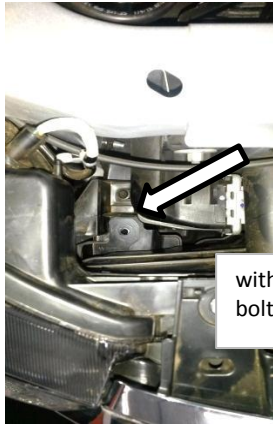

with top plastic removed you can access the bolt holding the grill on each side



remove top plastic cover above grill (Inside bonnet)



Remove Bolts holding the air deflector to the vehicle

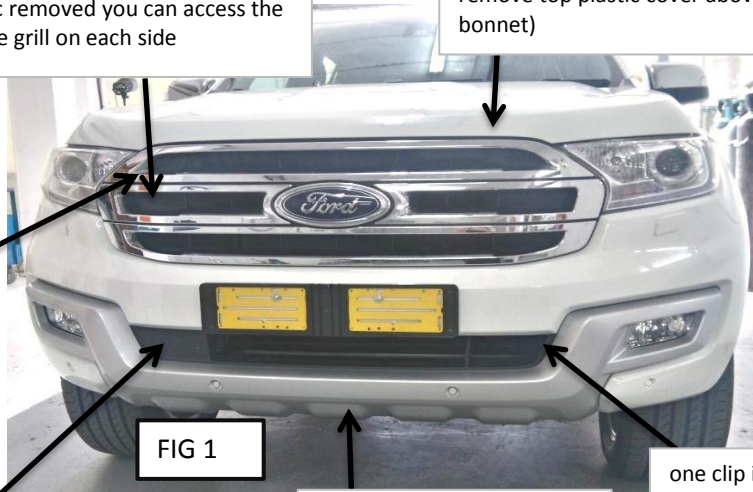
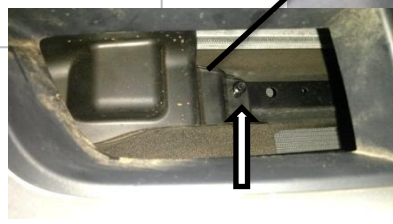

FIG 1

Clips under wheel arches

Clips , bolts and belly plate under vehicle

one clip inside of bumper on each side



Fitment Instruction: Ford Ranger Nudge

Visual / Graphic Illustration

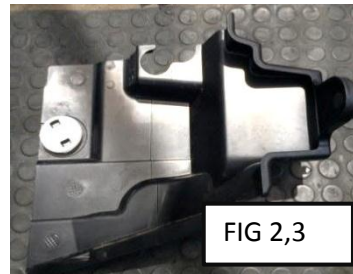

Step

Description/Method

1.1

You will also need to temporarily remove the brackets shown in Fig 2.2 to make fitment of brackets easier. The plastic shown in Fig 2.3 will also need to be removed prior to fitting as well. This can be discarded or cut as per Fig 2.4

1.2

Remove air deflectors from bumper. These will need to be trimmed. This is shown in FIG 6 on page 6.

Fitment Instruction: Ford Ranger Nudge

Visual / Graphic Illustration

FIG 3

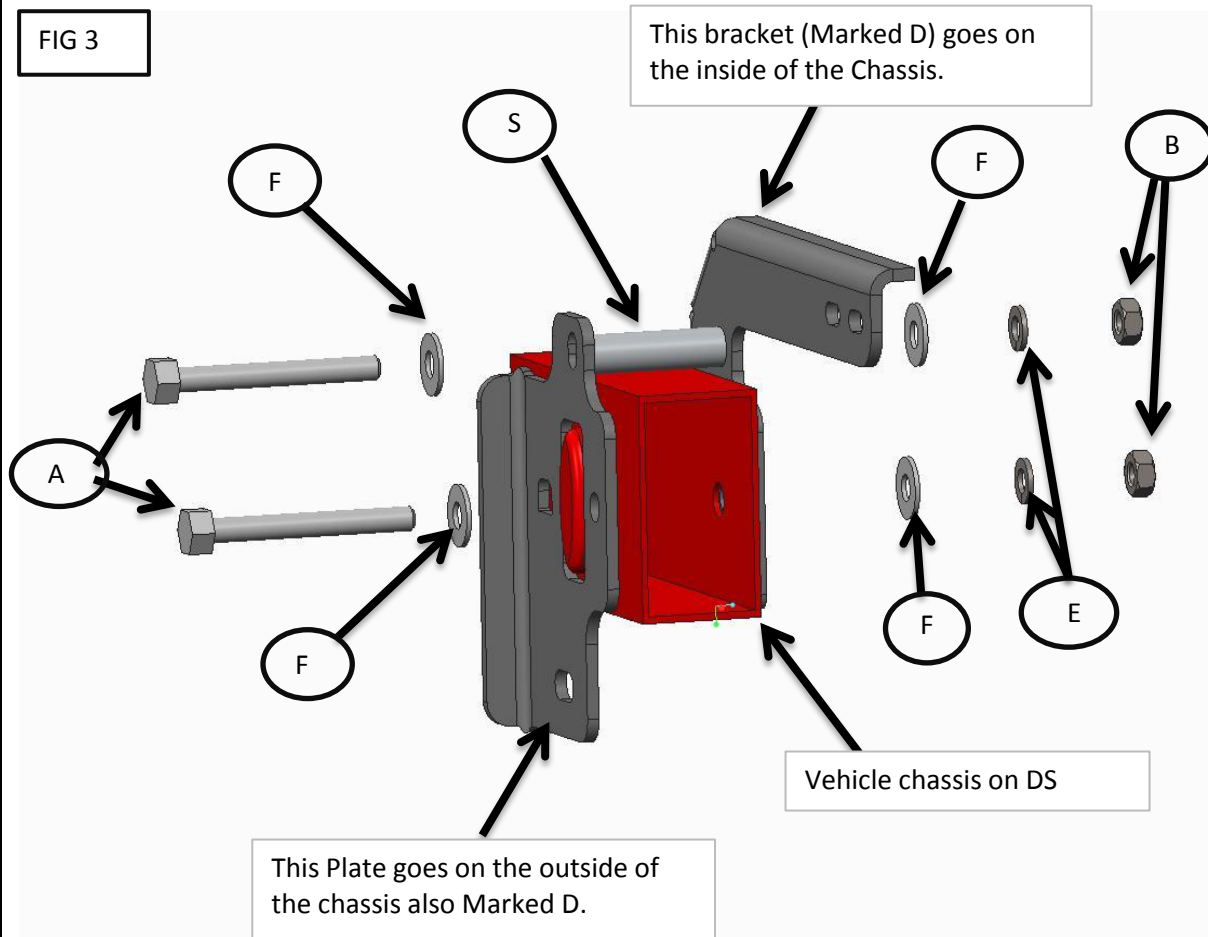

Step

Description/Method

2

Attach brackets to vehicle as shown in Fig 3 (Drivers side shown)

3

Ensure bracket is protruding straight as shown in the below image , if it is not straight it could cause it to foul with the bumper when bumper is replaced. Tighten the brackets when you are satisfied they are straight.

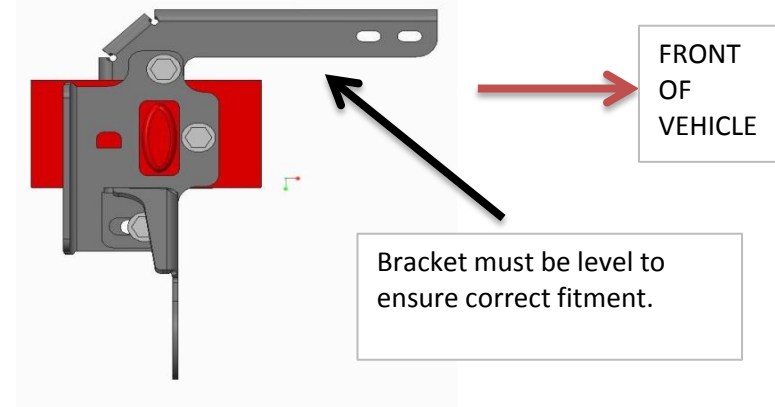

Fitment Instruction: Ford Ranger Nudge

Visual / Graphic Illustration

Step #

Description/Method

FIG 4

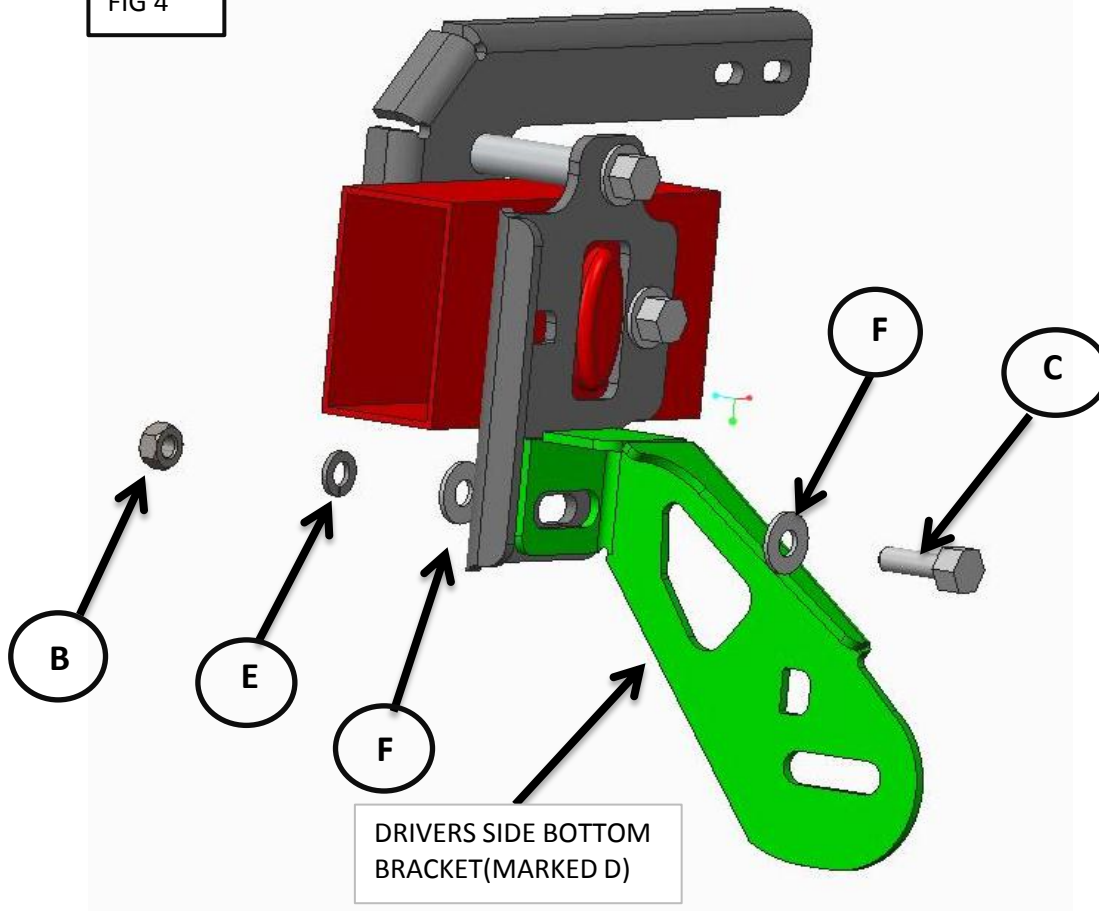
**4**

Now you can LOOSELY attach the bottom bracket as shown in Fig 4. Drivers side is shown, Bracket is marked D.

5

Now repeat the above steps for the Passenger side bracket , Fig 5 shows the brackets mounted to passenger side.

Fitment Instruction: Ford Ranger Nudge

Visual / Graphic Illustration

Step #

Description/Method

FIG 5

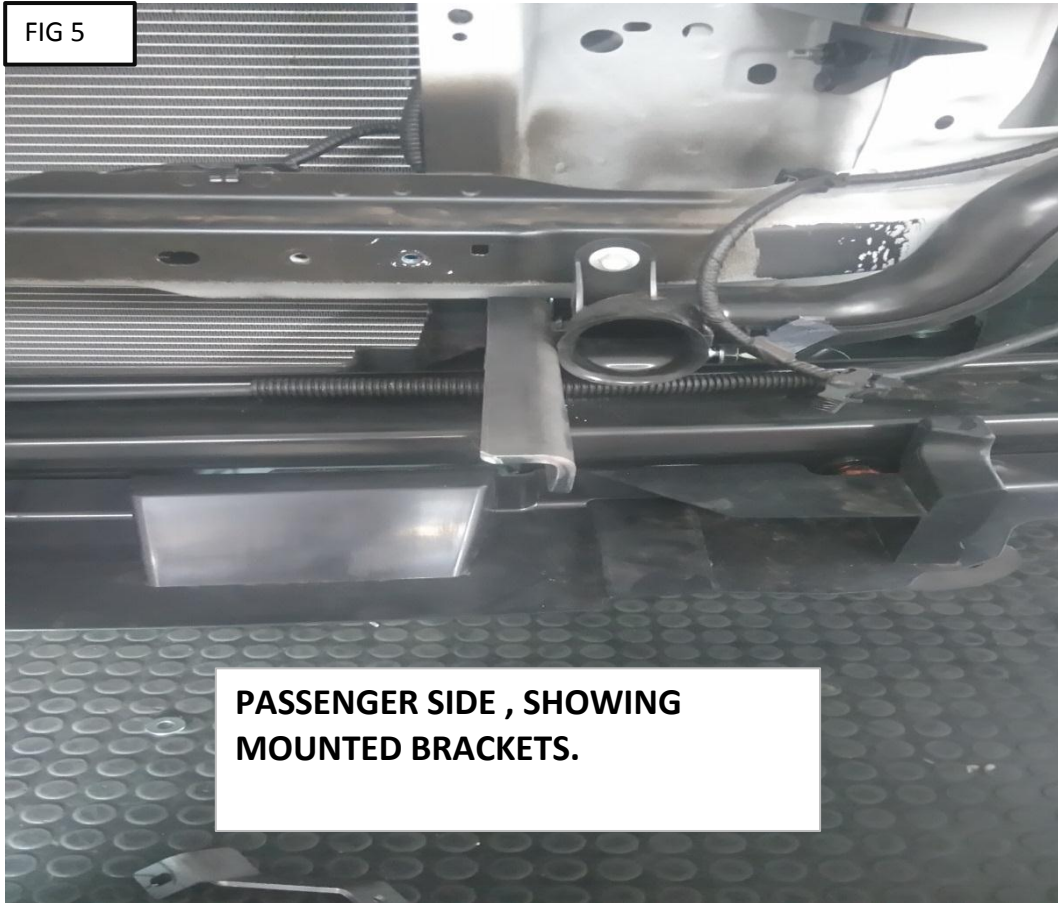

6

Once you have the brackets mounted and protruding as in Fig 5, you need to trim the plastic you removed. Fig 6 below shows where the cut needs to be made. Its advisable to trim away everything in the box as shown in the below image.

FIG 6

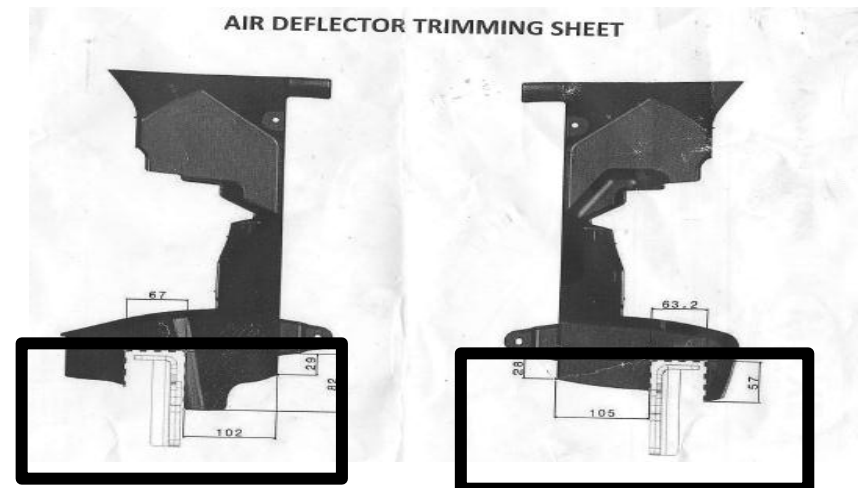

Fitment Instruction: Ford Ranger Nudge

Visual / Graphic Illustration



The rings show the position where the protruding brackets will be when bumper is replaced . **Note:** the brackets wont protrude all the way out the bumper.

Step

Description/Method

7

You can now replace the brackets you removed in step 1 and also replace the plastic cover followed by the bumper. Fig 7 shows the position of the brackets once the bumper is replaced.

8

Now assemble the intermediate brackets as shown in Fig 8 below.

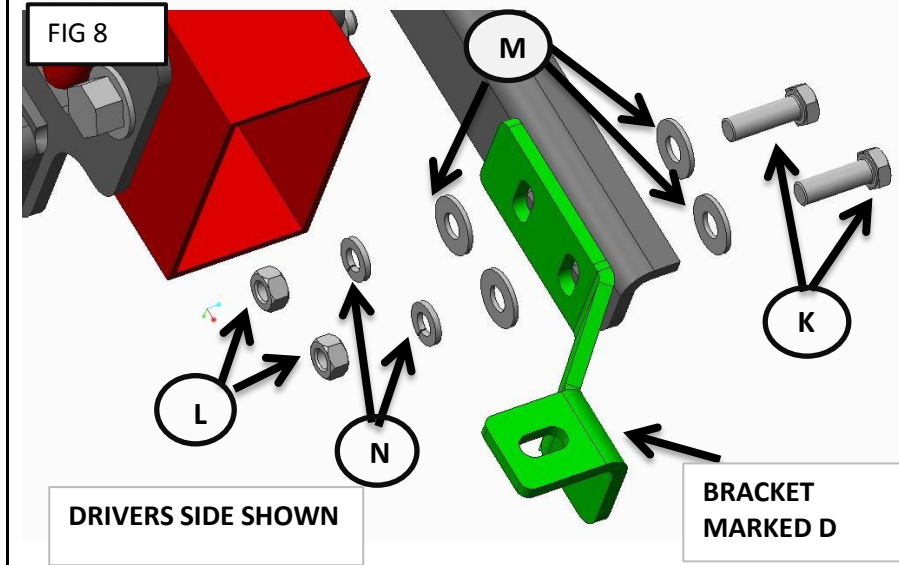

Fitment Instruction: Ford Ranger Nudge

Visual / Graphic Illustration

Step #

Description/Method

FIG 9

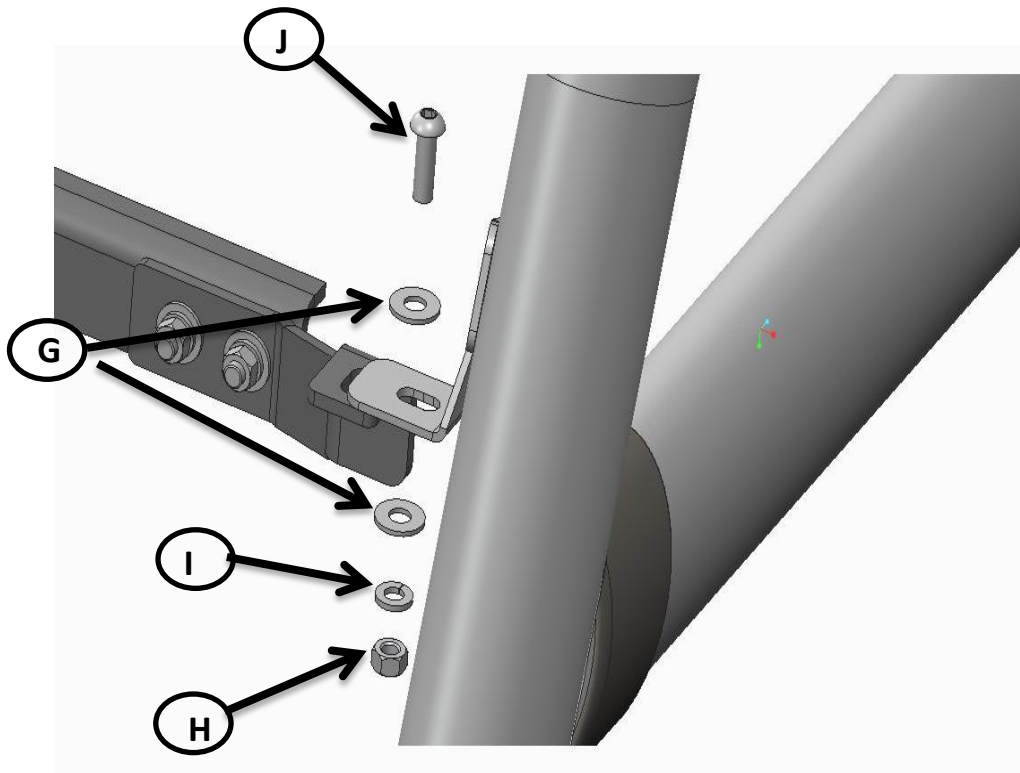

9

With all brackets now in Place you can place the nudge bar in place as shown in Fig 9 and 10.

FIG 10

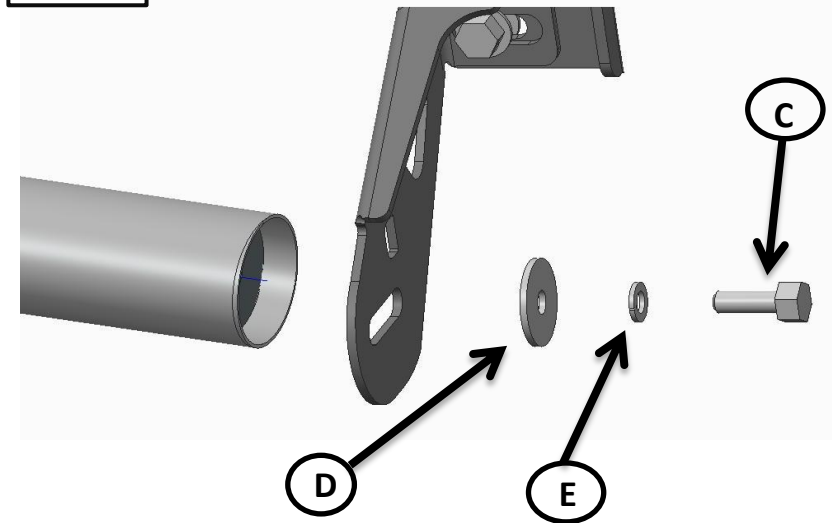

Make sure bar is centralised and tighten all fasteners to specified torque. M8= 22Nm , M10= 42Nm , M6= 9Nm.

