



Sabourin Series

Horn No.1300

Description

Ultra wide bandwidth point source sound is achieved by combining the GRS PT6825-8 planar driver with a large format front horn. The GRS PT6825-8 is a close equivalent replacement for the BG NEO8S planar driver. Applications include recording studios, audiophile two channel music, and home theater. This horn is suitable for both small or large listening spaces.

Constructed from 24mm Baltic birch plywood, this horn can be made using a miter saw and table saw.

To complete the system, a matching bass cabinet is offered to compliment the horn's performance and appearance. (See Sabourin Bass Cabinet No.1303)

Features

- 300Hz Low Frequency Cutoff (Fc)
- Wide controlled coverage
- Low distortion (-60dB IMD @ 90dB SPL1m)
- High SPL (105dB SPL 1m @ 0.76% D2 Harmonic Distortion, 300Hz)

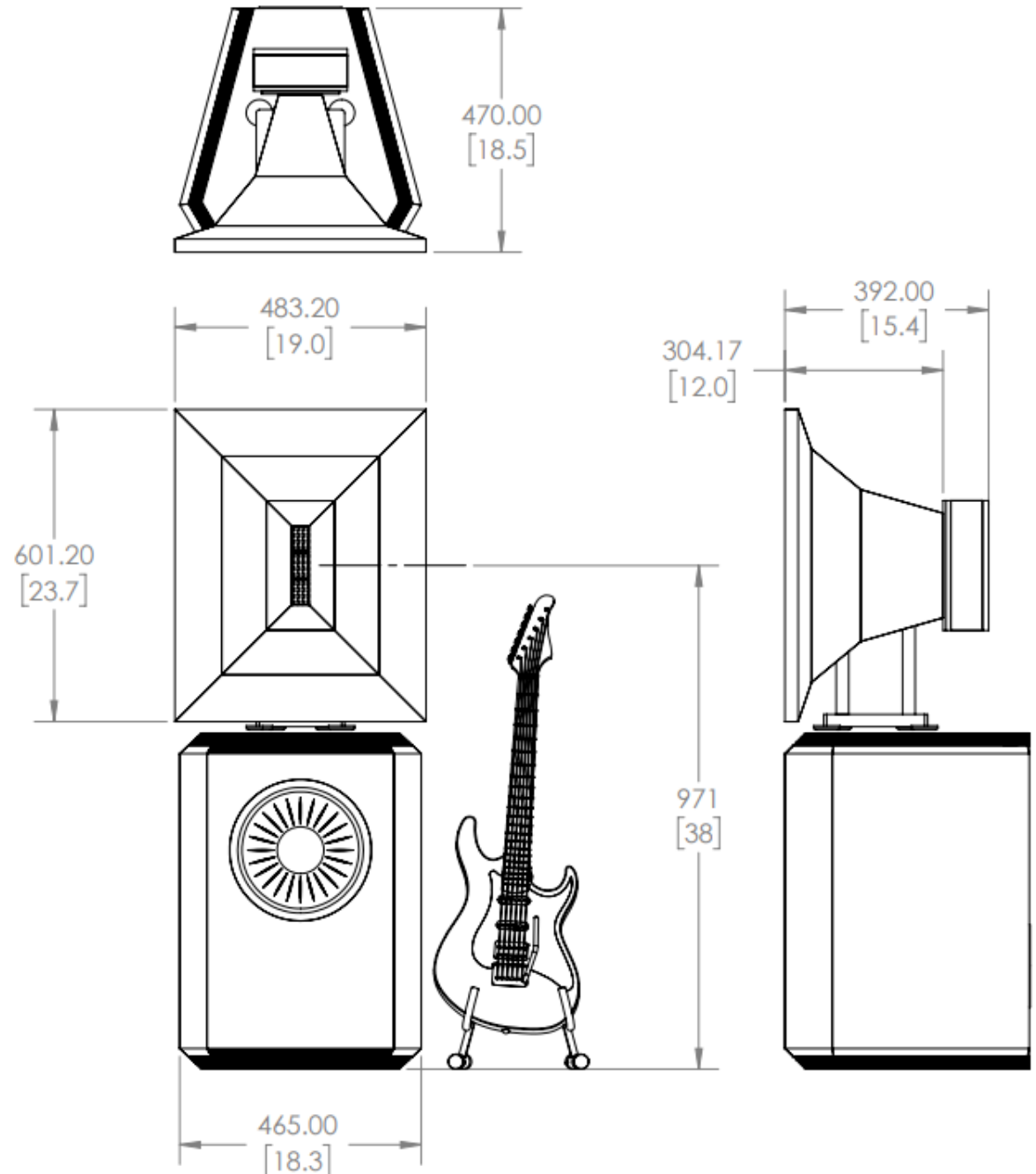

Frequency & Time Domain Performance

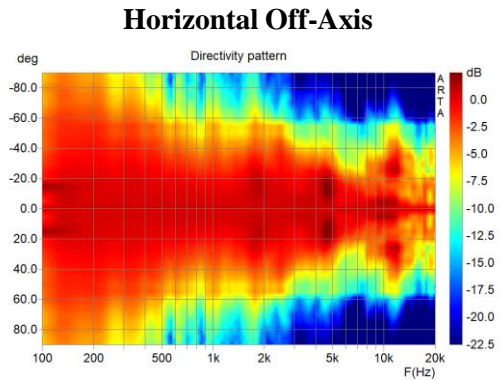
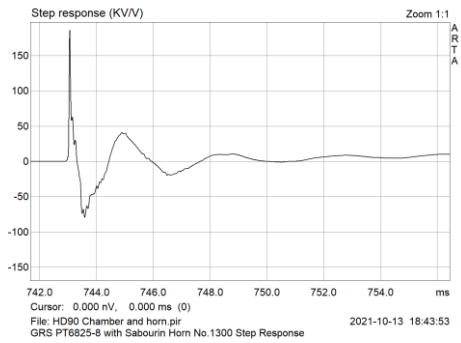
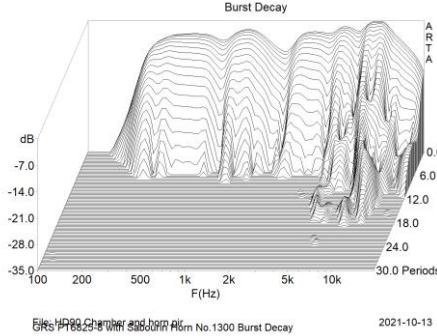
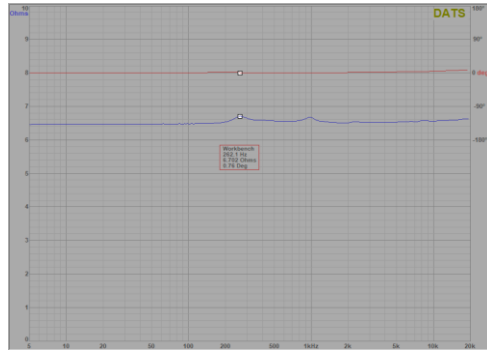
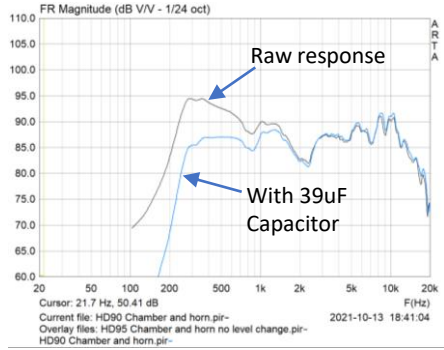

Distortion

Harmonic

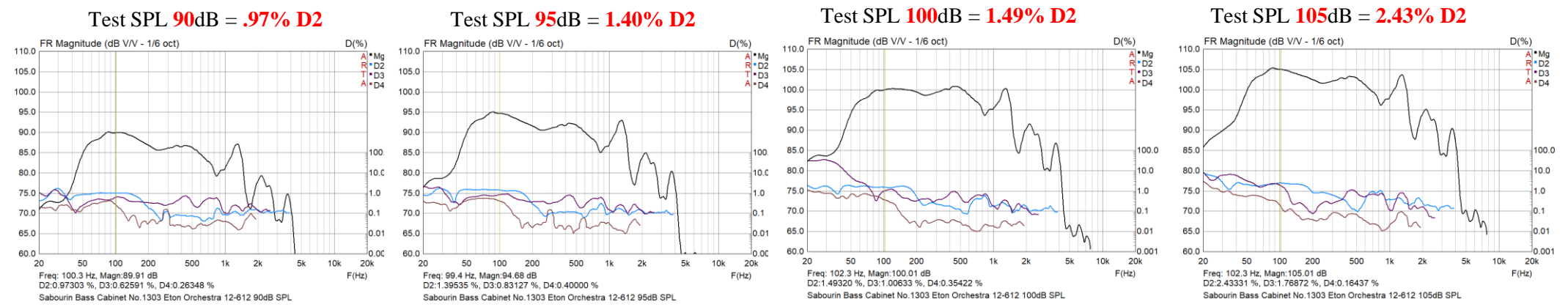

Intermodulation

