

XLP-8

Small, Simple, Extremely Low Power Vehicle Detector



1. Contents

Figures	3
2. Introduction	4
Functional Data.....	5
Electrical Data.....	6
Environmental Data.....	6
Mechanical Data	7
3. Features and Functions	8
Detector Reset.....	8
Presence Detection.....	8
Pulse Detection.....	8
Presence / Pulse Comparison	9
Sensitivity (Rotary Switch)	9
Diagnostic Mode (Sensitivity Setting 0).....	9
DIP Switch 1 - Frequency	10
DIP Switch 2 - Loop / Magnetometer	10
DIP Switch 3 - Normal Sensitivity / Sensitivity Boost.....	11
DIP Switch 4 - Fail-Safe / Fail-Secure	11
Relay Output.....	11
Indicators	12
4. Installation	14
Detector Installation.....	14
Loop Installation	14
Probe Installation	17
5. Configuration	19
Wiring	19
Sensitivity.....	19
DIP Switch 1 - Frequency	19
DIP Switch 2 - Loop / Magnetometer	19
DIP Switch 3 - Normal Sensitivity / Sensitivity Boost.....	20
DIP Switch 4 - Fail-Safe / Fail-Secure	20
6. Troubleshooting	22
No Power LED	22
Power LED Flashes Slowly (2Hz)	22
Power LED Displaying 1 Flash On, Every Two Seconds.....	22
Power LED Displaying 2 Flashes On, Every Two Seconds	23
Power LED Stays On.....	23
Power LED Flickers On at Irregular Times.....	23
In Diagnostic Mode, Power LED Flashes.....	24
Detect LED Intermittently Comes On / Stays On Without a Vehicle Present.....	24
Detect LED Will Not Come On With a Vehicle Present.....	25

Figures

Figure 1: Product Views.....	4
Figure 2: Physical Dimensions	7
Figure 3: Outputs.....	9
Figure 4: Power LED States.....	13
Figure 5: Loop Installation	16
Figure 6: Saw Cut for Home Run Exit and Chiseled Corner for Home Run Exit.....	16
Figure 7: Typical Probe Installation	17
Figure 8: free-exit probe Installation.....	18

2. Introduction

The XLP-8 is the first member of the XLP family of detectors. This family of detectors feature extremely low power detectors. The very low current draw and low voltage range is ideal for battery backed up and solar powered applications. The XLP-8 is specifically designed to be used in applications that require a small form factor with basic functionality with pluggability and a diagnostic mode to facilitate troubleshooting.

The XLP-8 can be connected to a standard inductive loop or one of Diablo Controls free-exit probes. The Diablo Controls free-exit probe is a small “pipe shaped” device approximately 4-1/2” by 1” and is designed to be buried in the ground to detect vehicles. Contact Diablo Controls for more information on the free-exit probe. The XLP-8 can be used as either a safety loop or free exit loop detector. It also has the flexibility to be either “fail-safe” or “fail-secure”. The XLP-8 has a relay output with both Normally Open and Normally Closed contacts.

The XLP-8 has 9 selectable sensitivity settings and uses a 4-position DIP switch to configure the detector. This includes the Diablo Controls free-exit probe selection as well as sensitivity boost, and fail- safe/fail secure operation. This makes the XLP-8 very flexible and versatile for those battery backed up and solar powered installations that need extremely low power consumption.

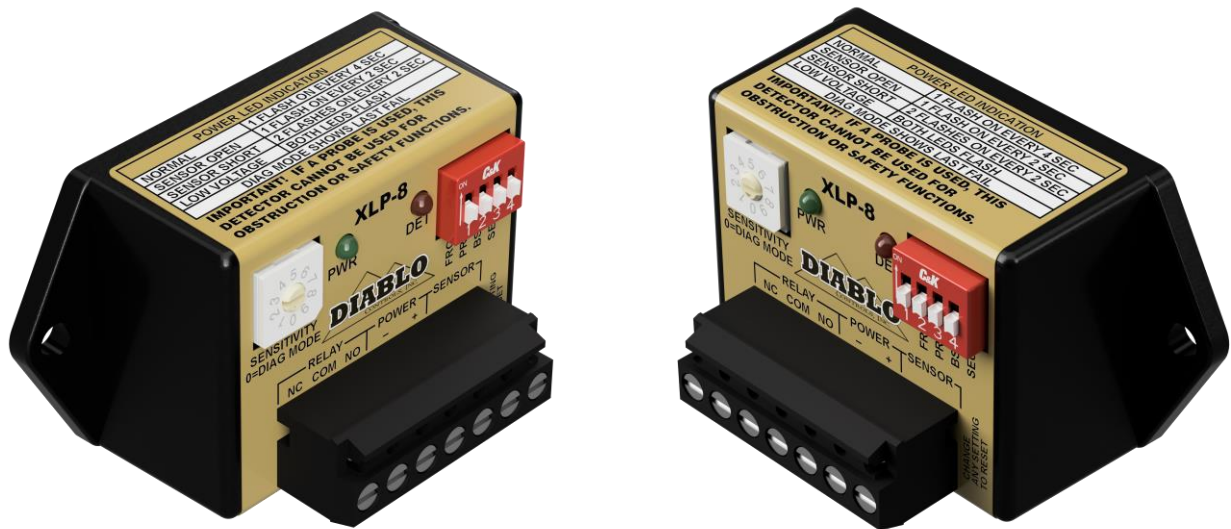

Figure 1: Product Views

Functional Data

Sensitivity: Ten sensitivities are user selectable.

Setting	Sensitivity	Setting	Sensitivity
0	Diagnostics Mode	5	.08% Δ L/L
1	.32% Δ L/L	6	.06% Δ L/L
2	.24% Δ L/L	7	.04% Δ L/L
3	.16% Δ L/L	8	.03% Δ L/L
4	.12% Δ L/L	9	.02% Δ L/L

Frequency Settings: There are four frequency settings available. The actual loop frequency is dependent on loop circuit inductance.

DIP Switch		Frequency
1	2	
OFF	OFF	High
OFF	ON	Medium Low
ON	OFF	Medium High
ON	ON	Low

Inductive Loop Response Time: Response time is dependent on the sensitivity selected.

Setting	Response Time	Setting	Response Time
0	Diagnostics Mode	5	160ms \pm 130ms
1	160ms \pm 130ms	6	160ms \pm 130ms
2	160ms \pm 130ms	7	200ms \pm 140ms
3	160ms \pm 130ms	8	200ms \pm 140ms
4	160ms \pm 130ms	9	200ms \pm 140ms

Free-exit probe Response Time: Response time is dependent on the sensitivity selected.

Setting	Response Time	Setting	Response Time
0	Diagnostics Mode	5	160ms \pm 130ms
1	160ms \pm 130ms	6	160ms \pm 130ms
2	160ms \pm 130ms	7	200ms \pm 140ms
3	160ms \pm 130ms	8	200ms \pm 140ms
4	160ms \pm 130ms	9	200ms \pm 140ms

Vehicle Hold Time: In Normal Presence Mode: Approximately 1 hour for a detection of 1% Δ L/L.
In Extended Presence Mode: Approximately 1 to 2 days for a detection of 1% Δ L/L.

Electrical Data

Loop Inductance:	20 microhenries to 1500 microhenries (including lead-in inductance). Not all frequency settings are available at inductances below 30 microhenries.	
Operating Voltages:	One wide range power version: 8 volts to 40 volts DC 8 volts to 28 volts AC (RMS)	
Relay Output Rating:	DC: 60 volts @ 1 amp AC: 125 volts @ 1 amp	
Current Draw:	Sensitivities 1 - 6:	Without detection is 0.85 ma maximum With detection is 30.00 ma maximum
	Sensitivities 7 - 9:	Without detection is 1.60 ma maximum With a detection is 30.00 ma maximum

Environmental Data

Operating Temperature:	-35°F to 165°F (-37°C to 74°C)
Storage Temperature:	-40°F to 176°F (-40°C to 80°C)
Humidity:	Up to 95% relative humidity non-condensing

Mechanical Data

Mounting Position: Any

Housing Material: ABS

Housing Size: 2.362 inches (High) x 2.008 inches (Wide) x .866 inches (Deep)
60.00 mm (High) x 51.00 mm (Wide) x 22.00 mm (Deep)

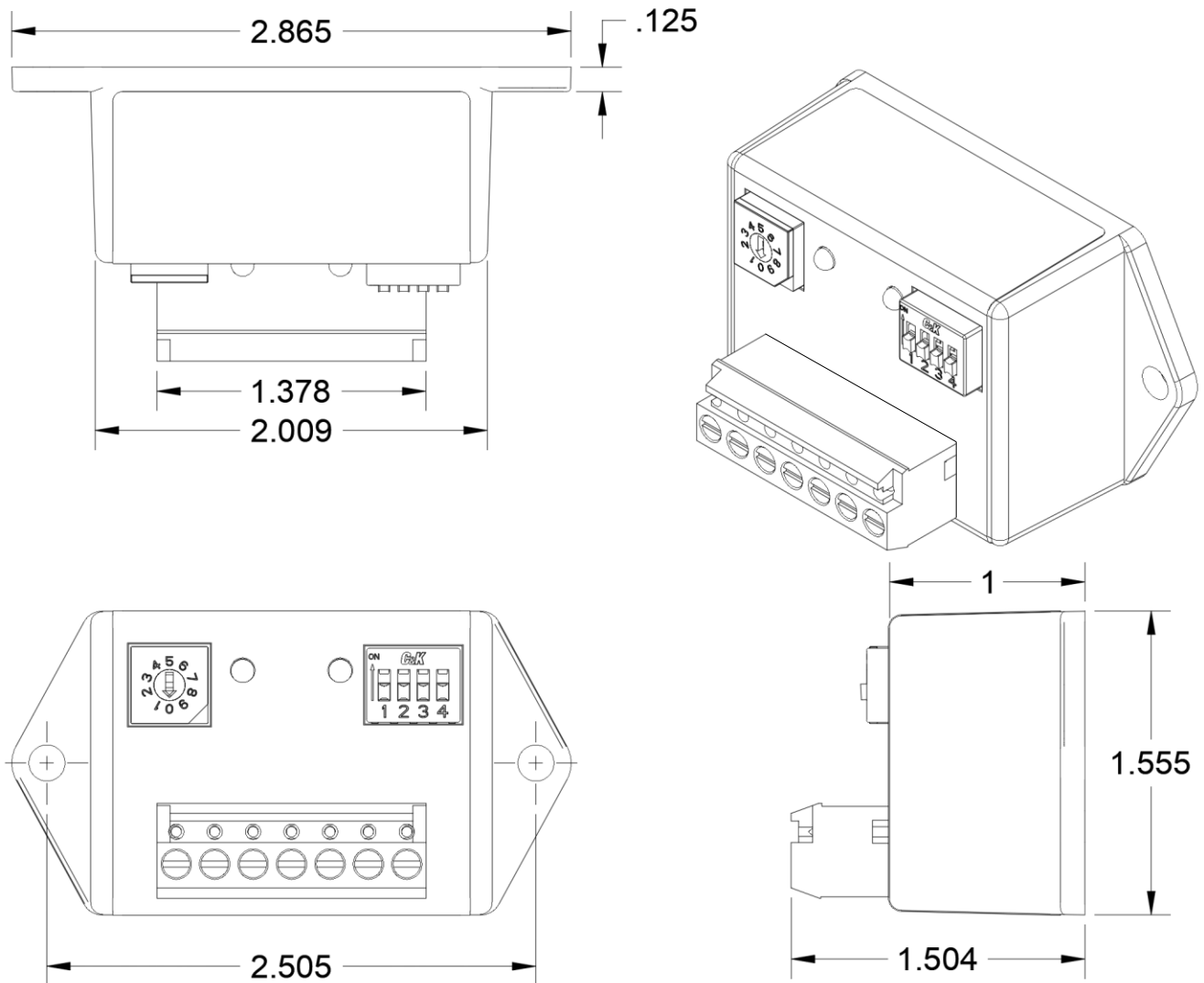

Figure 2: Physical Dimensions

3. Features and Functions

Detector Reset

When any of the DIP switches or the 10-position rotary switch is changed, or power is cycled to the detector, the detector will perform a reset. The reset event will last for two seconds while the detector initiates any changes and waits for all systems to stabilize. **NOTE:** If a vehicle is over the loop during the reset period it will not be detected.

Both LEDs will turn off for 500 milliseconds at the start of the reset event. After that, the red LED will flash according to its fail-safe or fail-secure mode of operation. A flash rate that is the same as the power LED indicates the output is operating as fail-safe. A much faster flash rate indicates that the output is operating in the fail-secure mode.

When a failure occurs, the output will be active if the detector is in the fail-safe mode. It will be inactive if in fail-secure.

Presence Detection

Presence detection is only available in the inductive loop mode of operation (DIP switch 2 OFF). If the detector is in the magnetometer mode of operation, only pulse operation is available.

While in the inductive loop mode of operation, the relay output will always operate in the presence detection mode. Once activated, the output will remain activated for as long as a vehicle is detected over the loop. After four minutes of continuous detection, the detector will begin to slowly retune the detector with the goal of tuning out the vehicle that stalled or parked on the loop over a relatively long time.

The time it takes to complete the retuning process is dependent on the strength of the detection being induced by the vehicle and the sensitivity setting. This usually takes between 15 minutes and about 24 hours. When the retuning process is complete, any loop area that vehicles can still travel over will still detect a vehicle as expected. Once the vehicle leaves, the detector will fully recover from the retuning process within a few seconds.

Pulse Detection

In the magnetometer mode of operation, the relay output is always configured for pulse on entry operation. The pulse generated by the relay output will be 250 milliseconds long. It is intended that there will be one output pulse for each car driving over the loop. However, if a vehicle remains over the detection area for longer than two seconds, a second pulse will be generated when the vehicle exits the area.

NOTE: The magnetometer mode of operation cannot be used if the detector will function as a safety or obstruction sensor as the probe is not capable of presence detection.

Presence / Pulse Comparison

The following figure shows how the detector output would respond to various vehicle sequences over the sensor. The numbers between edges are the number of seconds in that period.

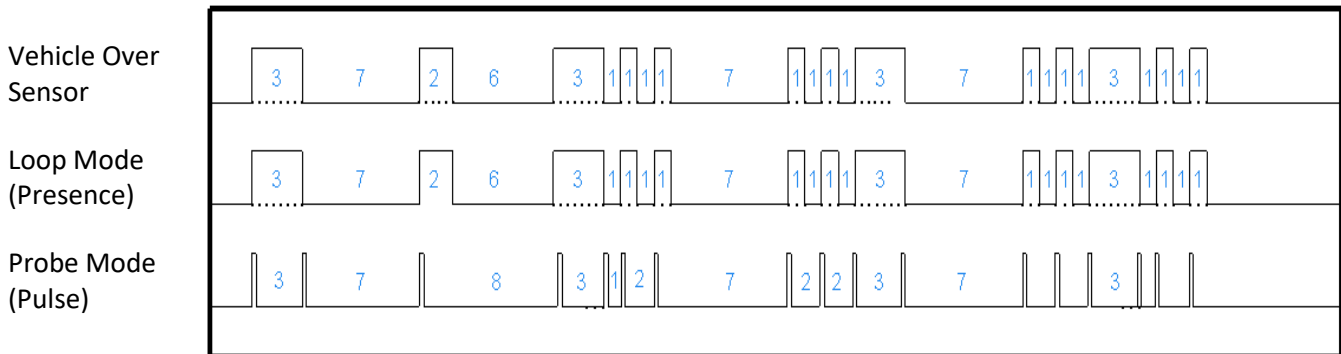

Figure 3: Outputs

Sensitivity (Rotary Switch)

The detector has nine (9) sensitivity levels and a diagnostic mode (setting 0). In most situations the sensitivity setting of five (5) will work effectively. For those situations where this setting is not sensitive enough, raise the sensitivity one level at a time until the desired performance is obtained. For those situations where the detector is overly sensitive, lower the sensitivity one level at a time until the desired performance is obtained. The factory default is five (5).

Like most inductive loop vehicle detectors, the XLP-8 directly measures the change in frequency of the loop and from there, calculates the change in inductance when a vehicle interacts with it. The change in inductance is measured as $\% \Delta L/L$ (reads as “percent delta L over L”).

For the nine sensitivities, the thresholds are:

Setting	Sensitivity	Setting	Sensitivity
0	DIAG MODE	5	.08% $\Delta L/L$
1	.32% $\Delta L/L$	6	.06% $\Delta L/L$
2	.24% $\Delta L/L$	7	.04% $\Delta L/L$
3	.16% $\Delta L/L$	8	.03% $\Delta L/L$
4	.12% $\Delta L/L$	9	.02% $\Delta L/L$

Factory Default

Diagnostic Mode (Sensitivity Setting 0)

The XLP-8 is equipped with a diagnostic mode that allows the user to view the last fault, if it occurred within seven days. When a fault is detected, the detector will continually attempt to recover from the fault. If the detector recovers from a fault, the fault is stored in the detector for seven days. After which it is cleared from memory. If the same fault occurs again during the seven days, the seven day period is restarted.

The diagnostic mode is activated by changing the sensitivity setting from the desired setting to zero. The user should remember the current setting before accessing the diagnostic mode so that the detector can be returned to that setting when done with the diagnostic mode.

While in the diagnostic mode, the green LED will flash the display for the last fault. See Indicators – Power LED for more information on this display. If the LED is on solid, there has not been a fault with in the last seven days or the detector was reset, and the fault memory cleared. The detector will continue to operate normally at the last used sensitivity while in the diagnostic mode.

DIP Switch 1 - Frequency

When loops are installed sufficiently far apart, any two loops will not interfere with each other. However, if two loops are fairly close together, say two to four feet apart, the inductive fields may couple together and may interact causing intermittent false detections. The main variables for inductive coupling are loop size, distance between loops, and the loop frequency. To aid in mitigating inductive coupling, each XLP-8 detector comes with two frequency settings.

If there are suspicions that loops are interacting, change one of the detector’s frequency settings so that their inherent frequencies are sufficiently different as to no longer interact. If the loops are the same size and number of turns, setting one detector to high and the other detector to low will provide the maximum frequency separation.

DIP Switch 1	Frequency
OFF	High
ON	Low

Factory Default

DIP Switch 2 - Loop / Magnetometer

The XLP-8 is capable of operating with either a standard inductive loop in the presence mode or a probe/free-exit probe (magnetometer). In the magnetometer mode of operation, the detector will only hold a detection for 2 seconds. Therefore, if a vehicle stays over the sensor for more than 2 seconds it may generate additional pulses for the same vehicle. The boost feature has no affect in the magnetometer mode of operation. The factory default is the inductive loop mode.

DIP Switch 2	Loop Type
OFF	Inductive Loop
ON	Probe (aka Free-exit probe or Magnetometer)

Factory Default

NOTE: The magnetometer mode of operation cannot be used if the detector will function as a safety or obstruction sensor as the probe (free-exit probe) is not capable of presence detection.

DIP Switch 3 - Normal Sensitivity / Sensitivity Boost

The detector has a user selectable feature that increases the sensitivity of the loop sensor after initial detection. This feature has no affect when the detector is in the probe (magnetometer) mode of operation. This feature is most often used to allow a detector to have a lower starting sensitivity and then increase it after a vehicle has been detected. This is useful in situations where high-bed tractor-trailer vehicles will be passing over the loop. With this feature, the detector may be able to detect the high-bed portion of the vehicle without having to be overly sensitive and susceptible to false detections. NOTE: If detection of high-bed tractor-trailers is required, correctly sized loops must be used.

DIP Switch 3	Sensitivity Boost	
OFF	Disabled	Factory Default
ON	Enabled	

DIP Switch 4 - Fail-Safe / Fail-Secure

On the XLP-8, the option for fail-safe or fail-secure only applies when in the inductive loop mode. In general, a fail-safe detector will activate the output when the sensor circuit is failed. This is useful on a safety or obstruction sensor to prevent accidental closure of a gate on a vehicle. On a free exit loop, this will keep the gate open until the situation is fixed. Fail-safe is used in applications where it is important to allow traffic flow to continue. A fail-secure detector will not activate the output when the loop circuit is failed. This will keep the gate closed. This is useful in high-security areas or installations where containment is needed.

The probe (magnetometer) mode is always fail-secure.

These failure modes only apply to the output when external power is applied. That is, the failure output is more of a loop failure output than a total failure output. When placed in the fail-safe position, the main output will be activated when the detector recognizes that the sensor is somehow compromised, like if a loop wire is disconnected from its terminal screw. If placed in the fail-secure position, the main output does not activate when a fault condition is identified.

DIP Switch 4	Failure Mode for Output A	
OFF	Fail-Safe	Factory Default
ON	Fail-Secure	

When a fault is identified the green Power LED will flash to indicate the type of fault that was found. See Indicators – Power LED for more information on this display.

Relay Output

The XLP-8 has one relay output and both Normally Open (NO) and Normally Closed (NC) contacts are provided.

Relay outputs have several advantages over solid-state outputs:

- Relay Output terminals are electrically isolated from all of the inputs and power connections
- Normally Open and Normally Closed contacts are provided
- Higher current switching
- No polarity of output terminals eases system connections
- Not easily damaged due to miswiring or electrical voltage spikes

But relays also have their limitations:

- Larger form factor
- Higher power consumption when relay is activated
- Outputs may have to be debounced (relay contacts bounce when closing)

Indicators

The XLP-8 is equipped with two (2) LED indicators: Power (Green) and Detect (Red).

Power LED – The green power LED indicates these possible states:

OFF	The voltage applied to the detector is less than the minimum display voltage of approximately 5 volts. The LED will be off.
RESET IN FAIL-SAFE	At the start of a reset event (a DIP switch change, sensitivity change, or power cycle) the LED will turn off for 500 milliseconds, on for 500 milliseconds, off for 500 milliseconds, and then display its normal state.
RESET IN FAIL-SECURE	At the start of a reset event (a DIP switch change, sensitivity change, or power cycle) the LED will turn off for 500 milliseconds, on for 500 milliseconds, blink repeatedly with 50 milliseconds on followed by 50 milliseconds off for one second, and then display its normal state.
LOW VOLTAGE	The voltage applied to the detector is more than the minimum display voltage of approximately 5 volts, but less than the minimum operating voltage of 8 volts, the LED will be blinking 250 ms on and 250 ms off.
OPEN LOOP	When the detector senses that the loop is open or the inductance is too high, the LED will flash on once for 150 milliseconds every two seconds. This usually indicates that there is no sensor attached or that the cable has been cut.
SHORTED LOOP	When the detector senses that a loop is shorted or the inductance is too low, the LED will flash on twice for 150 milliseconds every two seconds.
NORMAL	The LED will blip on once every four seconds when nothing is happening. The LED will turn on solid when the detector senses any activity over the loop.

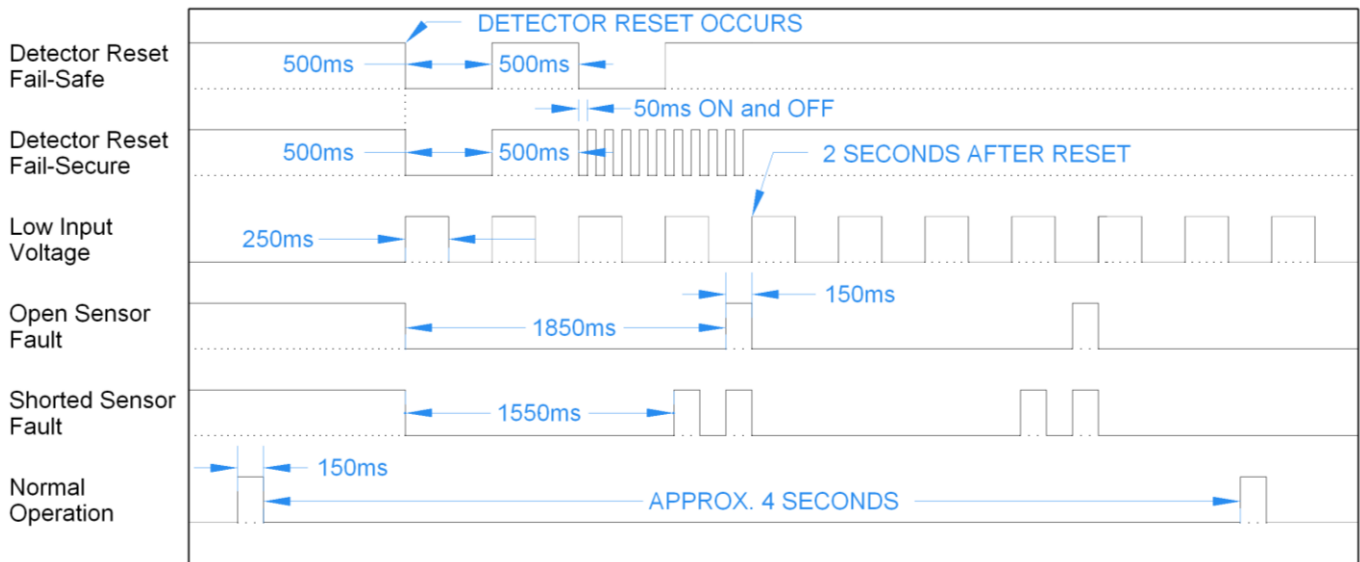

Figure 4: Power LED States

Detect LED – The red Detect LED is used to display the status of the relay output. There are several different statuses that can be displayed on this LED:

- Off** No vehicle present in the detection area or the detector has identified a fault and has deactivated the relay output because it is in fail-secure operation.
- Reset in Fail-safe** At the start of a reset event (a DIP switch change, sensitivity change, or power cycle) the LED will turn off for 500 milliseconds, on for 500 milliseconds, off for 500 milliseconds, on for 500 milliseconds, and then finally display its normal state. The relay output will be activated during this time.
- Reset in Fail-secure** At the start of a reset event (a DIP switch change, sensitivity change, or power cycle) the LED will turn off for 500 milliseconds, on for 500 milliseconds, blink repeatedly with 50 milliseconds on followed by 50 milliseconds off for one second, and then display its normal state. The relay output will be deactivated during this time.
- Relay Output Active** The LED will be on whenever the relay output is energized (Normally Open contact closed and Normally Closed contact open). If in the loop mode, this will be a presence output. If in the probe mode (magnetometer), this will be a pulse output.

4. Installation

Detector Installation

Location: The detector should be installed in a weatherproof location that is near the sensor. Ideally, a technician should be able to see the sensor and the detector at the same time.

Mounting: The detector will function when mounted in any orientation. Mount the detector such that the switches and LEDs on the detector will be easily accessible for configuration and troubleshooting.

Wiring: Before connecting to the detector, you should be certain that the voltage supplied to the detector is between 8 volts to 40 volts DC or 8 volts to 28 volts AC.

Wire nuts should never be used at any point in the sensor circuit itself. All sensor connections should be crimped or screw terminals at a minimum and soldered for best long-term reliability.

Special attention should be paid to ensure that the sensor wires remain tightly twisted together. An air gap between the two wires for a sensor may cause the detector to lock up if the wires are disturbed.

Loop Installation

The reliability and overall performance of the detector are greatly dependent on the loop itself. Several factors go into a good loop installation: type of wire used, loop configuration, and installation practices.

Type of Wire Used: The wire used for wiring the loop should have a jacket of cross-linked polyethylene or similar material that has very low moisture absorption properties. This would be a wire with an XLP jacket such as XHHW. THHN or similar wire types should never be used for loop wire.

The gauge of the wire to use depends on two factors: Distance in cable feet from the loop to the detector and stresses the wire may see. The gauge of the wire can be 20 AWG as long as the detector is within 50 feet of the loop in cable distance. For 50 to 100 feet, use at least 18 AWG wire. At greater than 100 feet, use a 16 AWG wire at a minimum. If the loop is installed in asphalt and there will be heavy vehicles or stopping and starting vehicles in the loop area, a 14 AWG or 12 AWG should be used to provide additional strength to the loop. This helps increase the life of the loop in areas where the asphalt may slowly move and/or deform due to wear.

Loop Configuration: The size and shape of the loop will determine what type of vehicles it can reliably detect. There are many variables that come into play including loop dimensions, percent of coverage, length of lead-in wire, number of turns in the loop area, and detection height to name just a few of them. One common rule is that the useable field height of a loop is $\frac{2}{3}$ of the shortest leg of the loop. So, if you plan on using a 2.5' x 6' loop, the expected useable detection height would be 20" (The shortest leg is 2.5' or 30", $30" \times 2 = 60"$, $60" / 3 = 20"$). If the installation requires the detection of motorcycles as well as vehicles, the loop should go to within one foot of the curb or roadway edge, whichever is present. If only motor vehicle detection is required, within three feet of the curb or roadway edge is all that is required.

The number of turns to use in a loop is dependent on the size of the loop, the amount of metal (rebar, cables, etc.), and distance from the loop to the detector. Rather than dive into all of the calculations to arrive at a value, we will just use safe values. You can almost never have too many turns in a loop, only too few. For a loop size of 2' x 6', four turns will be sufficient unless there is metal in the loop area. In that case add at least one turn, and two if possible. As the loop size reaches 6' x 6', four turns will work for most all installations. If you are unsure about your particular installation, call tech support for guidance.

Installation Practices: Permanent loops should be installed into the road surface by cutting slots into the road surface using a saw with an appropriate cutting disk for the road surface.

The slot cut should be wide enough that the wire being used will easily fit into the slot. This is needed so that the loop sealant used can fully encapsulate the wire. When the wire fits tightly in the slot, the sealant may not be able to get below the wire, leaving air pockets in the saw slot. If water finds its way into these air pockets, over time, freeze thaw cycles can slowly jack the loop out of the saw slot causing loop failure.

The saw slot should be deep enough that the loop wire will have a minimum of ½" of sealant over the top wire in the slot. More is better. Going too deep with the saw cut is also a concern. Deep cuts in a road surface may impact the structural strength of the roadway, especially if any reinforcement material is cut. Using a smaller gauge of wire will allow for shallower saw cuts.

The corners of the loop should be crosscut at a 45° to help prevent damage to the wire insulation during installation and temperature cycling. The angled cuts should be at least 9" back from where the corner would be. The saw cuts should not go any further than necessary to ensure that the saw slots are at full depth where they meet.

Special consideration should be given to where the home run saw cut meets the loop saw cuts. Here either an additional saw cut should be made as shown in Detail A or the inside of the sharp corner should be removed with a chisel as shown in Detail B.

Once the saw slot has been cut, the slot should be cleaned of all loose material. High-pressure air should be directed into the saw slot to remove all debris. This will also help remove dust from the saw cutting operation from the sides of the saw slot. This will allow better adhesion of the loop sealant to the saw slot.

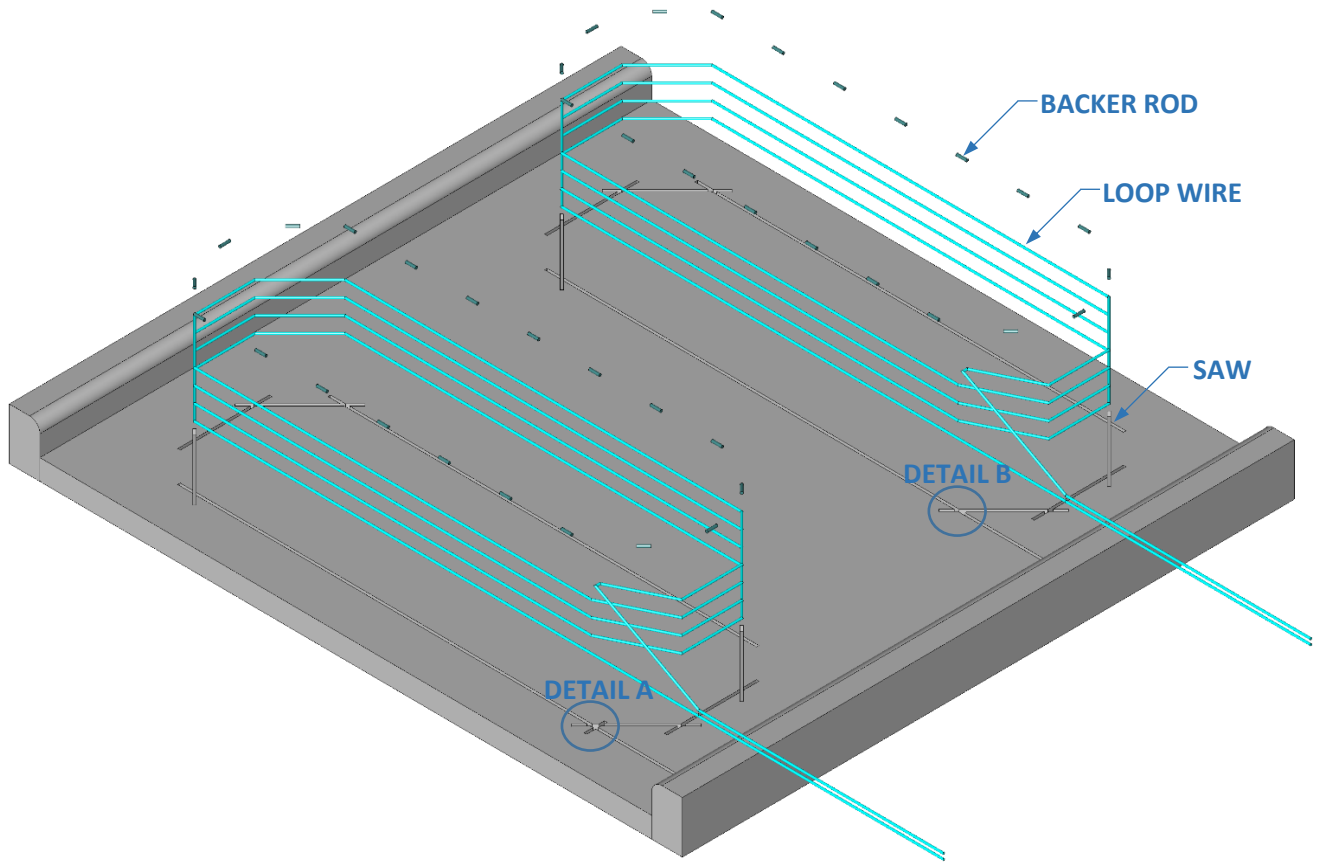

Figure 5: Loop Installation

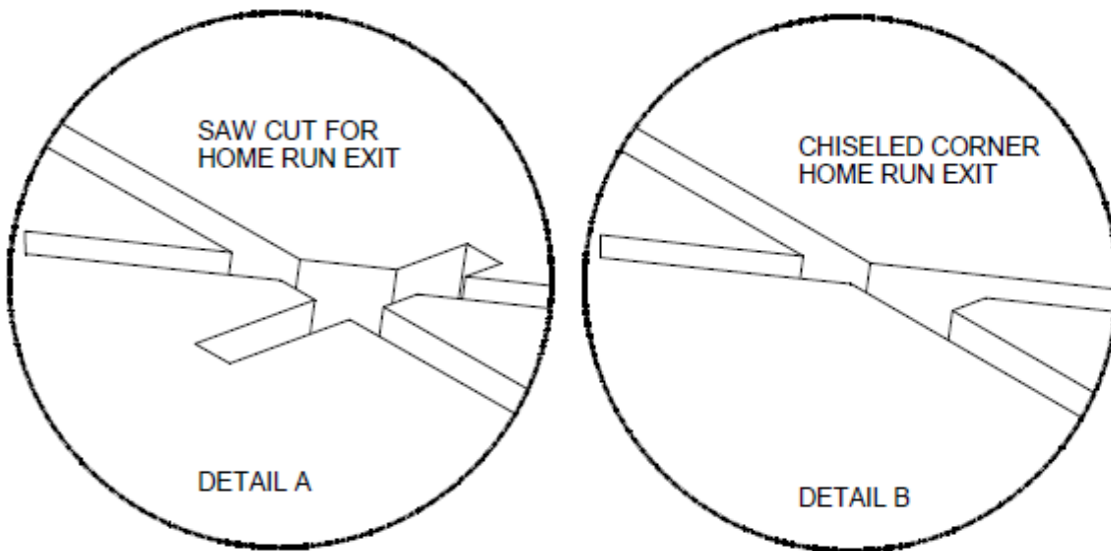

Figure 6: Saw Cut for Home Run Exit and Chiseled Corner for Home Run Exit

The loop wire should be installed as a continuous piece of wire from the detector to the loop, all of the turns in the loop, and back to the detector. Remember to make allowance for shrinkage in the wire length when the portion of the wire not in the roadway surface is twisted. The twisting is important for dealing with electrical noise. A splice of the loop wire should never be made in the roadway. If the loop wire needs to be spliced to another cable to get to the detector, the splice should be done in a junction box and the connections should be soldered and weatherproofed. Wire nuts should never be used at any point in the loop circuit.

In order to keep the loop wire at the bottom of the saw slot, 1" to 2" pieces of backer rod should be placed in the saw slot every 1 to 2 feet. The backer rod should be sized such that it fits snugly in the saw slot. Use a blunt object (not a screwdriver) to press the backer rod pieces down into the saw slot as far as they will go. Keeping the loop wire at the bottom of the saw slot allows the loop sealant to provide the maximum amount of protection possible from foreign object penetration. Never use a continuous piece of backer rod over the loop, as this would prevent the loop sealant from encapsulating the loop wire.

The loop sealant used should be appropriate for the roadway surface that was cut. Generally, epoxy or polyester based sealants are used for concrete surfaces and polyester or urethane-based sealants are used for asphalt surfaces. However, these are not hard guidelines and specific circumstances will determine which type of sealant should be used.

Once the loop wire leaves the saw slot it should be twisted at least three times per foot. More is better. The twists should be kept tight to be most effective in reducing the effects of electrical interference.

Probe Installation

Installation is straightforward. A 1½ to 2 inch diameter hole (6 to 12 inches deep) is drilled for the probe. A 1 inch deep, ¼ inch wide saw cut from the hole to the edge of the road provides a path for the lead-in wire. The probe with lead-in is inserted into the hole and the hole is filled to 1 inch from the top with dry sand. Loop sealant material is then used to fill the slot and top portion of the hole. 1 inch pieces of backer rod should be used every foot of the saw slot to keep the lead-in cable at the bottom of the saw slot.

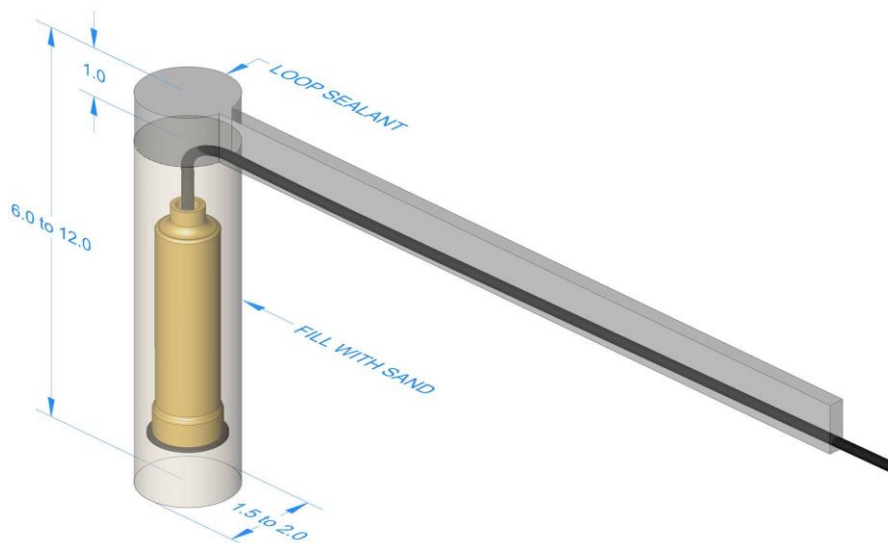

Figure 7: Typical Probe Installation

It is important that the probe be installed in a vertical position and that the vertical position of the probe be maintained. Under some soil conditions, installation can be further simplified by installing the probe inside a length of PVC pipe (not steel pipe) with an interior diameter of about 1½ inch. In this case, the hole must be slightly larger than the outside diameter of the PVC pipe, typically 2 inches. After insertion of the PVC pipe and probe, all cavities are back-filled with fine, dry sand and the installation completed in the normal manner.

Side Detection Zone Placement

When the roadway is less than 11 feet wide, it may be possible to place the probe on the side of the roadway and achieve acceptable detection performance. The probe can be installed at a 45-degree angle so that the top of the sensor points towards where the vehicle is to be detected. This can be very useful when applications where there is already an existing driving surface that the customer does not want disturbed.

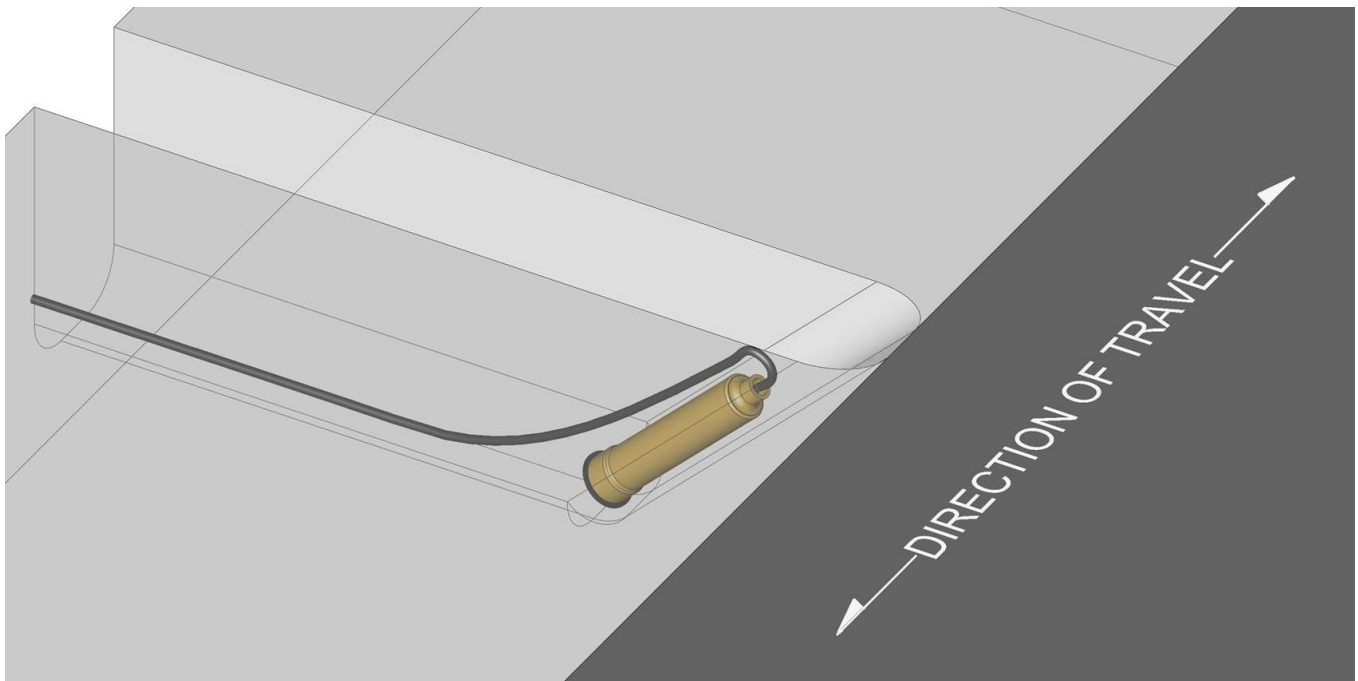

Figure 8: Probe Side Installation

When the roadway is greater than 11 feet wide, requiring a greater detection zone, you have two options. First is to add a second probe to the opposing side of the roadway. The probes must be wired in series. However, this configuration cuts the sensitivity of the probe in half and does not allow for different sensitivities for the two probes.

The second is to use another XLP-8 with its own probe installed on the opposite side of the roadway. In this configuration both probes have full sensitivity and their sensitivities are individually adjustable.

5. Configuration

Wiring

There is only one wiring configuration (pin-out) offered for the XLP-8.

Pin	Function
1	Output Relay – Normally Closed Contact
2	Output Relay – Common Contact
3	Output Relay – Normally Closed Contact
4	DC - or AC Neutral
5	DC + or AC (must be less than 40VDC or 28 VAC)
6	Sensor – Loop or Probe
7	Sensor – Loop or Probe

Sensitivity

The detector has nine (9) sensitivity levels and a diagnostic mode (setting 0). In most situations the sensitivity setting of five (5) will work effectively. For those situations where this setting is not sensitive enough, raise the sensitivity one level at a time until the desired performance is obtained. For those situations where the detector is overly sensitive, lower the sensitivity one level at a time until the desired performance is obtained. The factory default is five (5).

DIP Switch 1 - Frequency

When loops are installed sufficiently far apart, any two loops will not interfere with each other. However, if two loops are fairly close together, say two to four feet apart, the inductive fields may couple together and may interact causing intermittent false detections. The main variables for inductive coupling are loop size, distance between loops, and the loop frequency. To aid in mitigating inductive coupling, each XLP-8 detector comes with two frequency settings.

If there are suspicions that loops are interacting, change one of the detector's frequency settings so that their inherent frequencies are sufficiently different as to no longer interact. If the loops are the same size and number of turns, setting one detector to high and the other detector to low will provide the maximum frequency separation.

DIP Switch 1	Frequency	
OFF	High	Factory Default
ON	Low	

DIP Switch 2 - Loop / Magnetometer

The XLP-8 is capable of operating with either a standard inductive loop in the presence mode or a probe/free-exit probe (magnetometer). In the magnetometer mode of operation, the detector will only hold a detection for 2

seconds. Therefore, if a vehicle stays over the sensor for more than 2 seconds it may generate additional pulses for the same vehicle. The boost feature has no affect in the magnetometer mode of operation. The factory default is the inductive loop mode.

It is possible to configure the detector for a probe and connect a loop. Tis special configuration will operate correctly with the loop operating in a pulse mode rather than the presence mode.

The opposite situation of being configured for a loop with a probe connected should never be used. The configuration may seem to work, but will cause the detector to occasionally get stuck in detect after detecting a vehicle.

DIP Switch 2	Loop Type
OFF	Inductive Loop
ON	Probe (aka Free-exit probe or Magnetometer)

Factory Default

NOTE: The magnetometer mode of operation cannot be used if the detector will function as a safety or obstruction sensor as the probe (free-exit probe) is not capable of presence detection.

DIP Switch 3 - Normal Sensitivity / Sensitivity Boost

The detector has a user selectable feature that increases the sensitivity of the loop sensor after initial detection. This feature has no affect when the detector is in the probe (magnetometer) mode of operation. This feature is most often used to allow a detector to have a lower starting sensitivity and then increase it after a vehicle has been detected. This is useful in situations where high-bed tractor-trailer vehicles will be passing over the loop. With this feature, the detector may be able to detect the high-bed portion of the vehicle without having to be overly sensitive and susceptible to false detections. NOTE: If detection of high-bed tractor-trailers is required, correctly sized loops must be used.

DIP Switch 3	Sensitivity Boost
OFF	Disabled
ON	Enabled

Factory Default

DIP Switch 4 - Fail-Safe / Fail-Secure

On the XLP-8, the option for fail-safe or fail-secure only applies when in the inductive loop mode. In general, a fail-safe detector will activate the output when the sensor circuit is failed. This is useful on a safety or obstruction sensor to prevent accidental closure of a gate on a vehicle. On a free exit loop, this will keep the gate open until the situation is fixed. Fail-safe is used in applications where it is important to allow traffic flow to continue. A fail-secure detector will not activate the output when the loop circuit is failed. This will keep the gate closed. This is useful in high-security areas or installations where containment is needed.

The probe (magnetometer) mode is always fail-secure.

These failure modes only apply to the output when external power is applied. That is, the failure output is more of a loop failure output than a total failure output. When placed in the fail-safe position, the main output will be activated when the detector recognizes that the sensor is somehow compromised, like if a loop wire is disconnected from its terminal screw. If placed in the fail-secure position, the main output does not activate when a fault condition is identified.

DIP Switch 4	Failure Mode for Output A	
OFF	Fail-Safe	Factory Default
ON	Fail-Secure	

When a fault is identified the green Power LED will flash to indicate the type of fault that was found. See Indicators – Power LED for more information on this display.

6. Troubleshooting

No Power LED

The first step is to ensure that the correct model of the detector is being used for the installation. Ensure that the wiring is correct, and the correct voltage is being used.

Use a meter to measure the voltage applied to the detector. The voltage must be between 8 volts DC and 40 volts DC or 8 volts and 28 volts AC.

If the correct voltage is applied and the power LED is not blipping on once every four seconds, replace the detector.

Power LED Flashes Slowly (2Hz)

This flash rate indicates that the detector has insufficient voltage applied to it. Use a meter to measure the voltage applied to the detector. The voltage must be between 8 volts DC and 40 volts DC or 8 volts and 28 volts AC.

If the correct voltage is applied and the power LED is still flashing, replace the detector.

Power LED Displaying 1 Flash On, Every Two Seconds

This flash rate indicates that the detector has an open sensor, a high resistance in the sensor circuit, or excessive inductance.

The first step is to confirm that the detector has a sensor connected to it and the sensor is connected to the correct pins (see the wiring configuration for the pin out).

If a sensor is connected to the correct pins of the detector, disconnect the sensor and using an ohmmeter, check the resistance of the sensor circuit. If the resistance is above 5 ohms there is a bad connection, or the wire has been damaged. The resistance will typically be 1.5 ohms or less.

If the resistance is below 5 ohms, the sensor inductance should be checked. This is done using an inductance meter. The inductance of the sensor should be less than 1500 microhenries. It is very unusual to have a loop with an inductance value this high, but it is possible with very large loops and many turns. If the sensor inductance value is above 1500 microhenries, the loop will have to be replaced with a loop with less inductance. Contact technical support for help with very large loops.

If you do not have a meter capable of measuring resistance and inductance but do have another operating detector in the same control box, you can skip to this step. Swap the sensor between a working detector and a failing detector. If the problem follows the sensor the sensor is the problem. If it stays in the same detector, replace the detector.

Power LED Displaying 2 Flashes On, Every Two Seconds

This flash rate indicates that the channel has a shorted sensor, a low resistance across the sensor circuit, or insufficient inductance.

The first step is to confirm that the sensor is connected to the correct pins (see the wiring configuration for the pin out). If the wiring is correct, the next step is to confirm that the detector is working correctly. Disconnect the sensor wires for the detector. The LED should begin flashing just once every two seconds instead of twice. If it does not change the flashing count, change the detector.

If a sensor is connected to the correct pins of the detector, disconnect the sensor and using an ohmmeter, check the resistance of the sensor circuit. If the resistance is below 0.2 ohms there is a short in the sensor circuit. The resistance will typically be 0.5 ohms to 1.5 ohms.

If the resistance is above 0.2 ohms, the sensor inductance should be checked. This is done using an inductance meter. The inductance of the sensor should be more than 20 microhenries. If the sensor inductance is less than 20 microhenries, the sensor was probably not wound correctly and only has one turn in it. In this case the sensor must be replaced. Other possibilities include a foreign object embedded in the saw slot and shorting some or all of the wires, or failed wire insulation due to the wire being exposed or the wrong type of wire being used. Very small loops may also have a low inductance value if sufficient turns were not added. Contact technical support for help with very small loops.

If you do not have a meter capable of measuring resistance and inductance but do have another operating detector in the same control box, you can skip to this step. Swap the sensor between a working detector and a failing detector. If the problem follows the sensor the sensor is the problem. If it stays in the same detector,

Power LED Stays On

This happens when the detector is in the diagnostic mode (sensitivity 0) and there is no remembered fault. Change the sensitivity to the desired setting.

Power LED Flickers On at Irregular Times

This happens when the detector is detecting noise that is strong enough to possibly cause false detections. See Electrical Interference under Detect LED Intermittently Comes On / Stays On Without a Vehicle Present in this troubleshooting section for possible causes and resolutions.

In Diagnostic Mode, Power LED Flashes

These flashes indicate that the detector has had a failure in the last seven days. There are three types of failures that the detector will remember:

Flashes	Remembered Failure
1 Flash Every 2 Seconds	Open Sensor Failure
2 Flashes Every 2 Seconds	Shorted Sensor Failure
50% On and Off Flashing	Low Voltage

Intermittent failures are usually open loop failures. Any splices in the sensor wire should be redone. If there are any wire nuts used in the sensor circuit, remove them, and replace with a crimp connection or preferably, a soldered connection. The open sensor fault could also be a fatigued point in the sensor wire. This can occur at locations where the sensor wires cross an expansion joint in the road surface. Any place where the sensor wires must move, even if only a very tiny amount, can cause wire fatigue. The actual failure point may be very difficult to find. Often the sensor must just be replaced if the issue persists but cannot be found.

It is possible for the intermittent failure to be a shorted sensor fault. One possible source of this type of fault is a foreign object being embedded in the sensor saw cut and damaging the wire. Another is that the sensor wire has been damaged where it enters or exits a conduit or junction box, or that a conduit that the sensor wire is in has been damaged (crushed, kinked, bent, cut, etc.).

The low voltage failure is usually only seen in battery backed up or solar power applications. This fault would indicate that the battery voltage dropped below 8 volts for at least one second. 8 volts is required to ensure that the output relay will actually energize when a detection occurs.

Detect LED Intermittently Comes On / Stays On Without a Vehicle Present

This type of symptom is usually caused by one of three issues: physical issues with the loop, electrical interference, moving objects in proximity to the loop.

Physical Issues with the Loop – There are many ways in which a loop installation can go bad. The insulation of the loop wire can fail. This can be due to the loop wire being exposed in the saw lot, damage to the wire insulation during loop installation, physical stressing of the wire due to movement (crossing of expansion joints or asphalt that has slowly moved or deformed), wires moving in the saw slot due to poor loop sealant encapsulation, foreign objects embedded in the saw slot, and poor electrical connections in the loop circuit.

The best way to check for any of these issues is to use a megohmmeter (commonly referred to as a megger). Disconnect the loop wires in question from the vehicle detector and any other electronic equipment. Connect one lead of the megger to one end of the loop wire and the other lead to earth ground. Measure the resistance. For accurate measurements the ground and the loop should be wet or at least damp (use a hose or a bucket of water if needed to get the area wet). The reading should be at least 100 megohms. If it is less than 50 megohms the insulation is compromised, and the loop circuit has to be replaced. Between 50 and 100 megohms, the loop may or may not work properly and reliably.

Electrical Interference – There are several possible sources of electrical interference: loop cross-talk, power lines, electric motors, and insufficient twisting of the loop wires, just to name a few.

Other loops in the area that are connected to a different detector are prone to cross-talk (when the magnetic fields from different loops interfere with each other). Adjusting the loop frequency of one or both of the loops in the same area will usually allow you to find a setting that both loops will work reliably with.

Anything that uses electricity is a possible source for electrical interference depending on its proximity to the loop and the amount of energy being used. If you believe the loop is experiencing electrical interference, turn off the device believed to be the source of the interference and see if the problem goes away. Sometimes this is not possible and more technical means are needed to help identify the source. Call Technical Support in this case.

If the electrical interference is occurring in the wire from the loop to the detector, additional twisting should help mitigate the issue.

Moving Objects in Proximity to the Loop – Objects that can move and are metallic or somehow electrically conductive, may cause detection issues.

A common issue is movement of a slide gate or gate arm in close proximity to a loop. The best solution would be to move the detection area further away from the moving gate. We recommend that all loops should be at least 4 feet from a slide gate. Try lowering the sensitivity one level so that the desired vehicles are still detected, but not the moving gate. NOTE: Do not lower the sensitivity too much or vehicles will no longer be detected.

Another possibility is metal objects in close proximity to the loop. Utility manhole covers are objects that may move slightly when vehicle tires drive over them, especially if the vehicle turns while a tire is on the cover. Most manhole covers can be bolted in place. Contact the owner of the manhole to see what can be done to mitigate the cover movement.

Detect LED Will Not Come On With a Vehicle Present

The first thing to do is verify that the LED in question is still working. This is accomplished by a quick lamp test. Reset the detector by temporarily changing DIP switch 4. Both LEDs should turn off and turn on. If the Detect LED does not illuminate, replace the detector.

If the red LED illuminates, then perhaps the sensitivity setting is too low. There are many variables in determining overall sensitivity: loop size, number of turns, loop lead-in, percent coverage, etc. In most cases, a sensitivity setting of 5 is the correct setting. However, to compensate for some unusual loop geometries, this setting may be inadequate. Adjust the sensitivity one level higher and recheck the detector for proper detection.

If the channel sensitivity is set to 9 and the red LED still does not come on and you have another operating detector in the same box, swap the sensors between a working detector and a failing detector. If the problem follows the sensor the sensor is the problem. If it stays in the same detector, replace the detector.