

## INSTALLATION MANUAL



# INTRODUCTION

The Pulse Mini is a mini single door control panel, can work with any Wiegand 26~37 bits output reader. It uses Atmel microcontroller to assure stable performance, and equips with an infrared remote control for easy operation. The Pulse Mini supports 1,000 users; all user data can be transferred.

## Features

- > 1,000 users' user data can be transferred
- > Multi access modes: Card, Card or PIN, Card with PIN and multi Cards/PINs
- > Can connect with any reader with Wiegand 26~37 bits output
- > Can connect with any keypad reader with 4bits, 8bits (ASCII), or 10bits Virtual number output
- > Support Master Card function
- > Low temperature resistance (-40°C)

## Specifications

User Capacity	1,000
<b>Operating Voltage</b> Idle Current	<b>9~24V DC</b> <20mA
<b>Relay</b> Adjustable Relay Output Time Lock Output Load	1~99 Seconds (5 seconds default) 2 Amp Maximum
<b>Wiegand Interface</b> Input Output	Wiegand 26~37 bits Wiegand 26~37 bits (for user transfer)
<b>Environment</b> Operating Temperature Operating Humidity	-40°C~60°C (-40°F~140°F) 0~90%RH
<b>Physical</b> Color Dimensions Unit Weight Shipping Weight	<b>ABS Shell</b> Black (White optional) L65mm × W54mm × D19mm 40g 100g

## Package Inventory

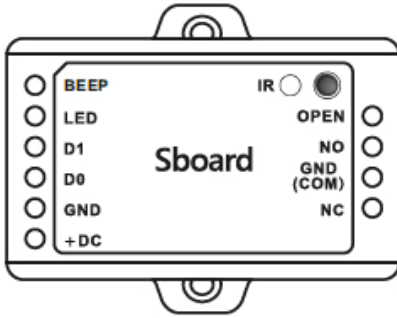

Pulse Mini

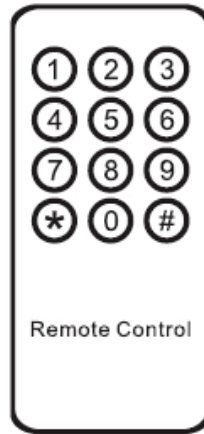

Infrared Remote Control



Diode IN4004 (For relay circuit protection)



Self Tapping Screws:  $\Phi 3 \times 25$ mm



Wall Anchors



Screw Driver

## INSTALLATION

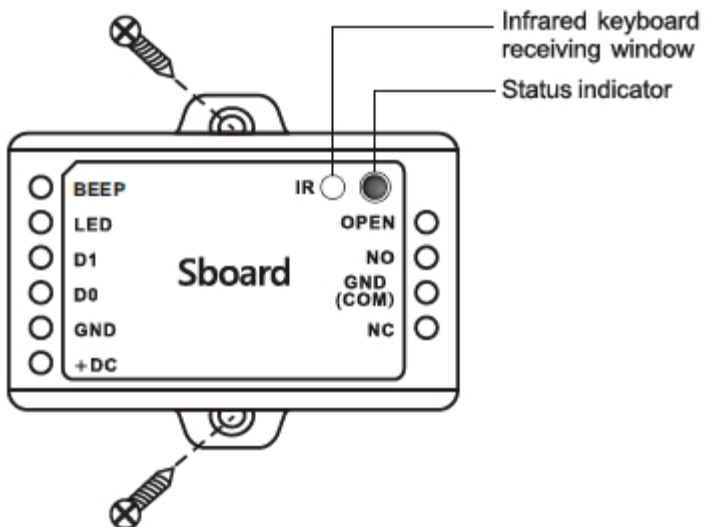

## Wiring

Name	Notes
The Left Side	
BEEP	Beep/ Buzzer Control
LED	Green LED Light Control
D1	Wiegand Input Data 1
D0	Wiegand Input Data 0
GND	Negative Pole of DC (9~24V) Power Input
+DC	Positive Pole of DC (9~24V) Power Input
The Right Side	
OPEN	Connect to One Wire of Exit Button
NO	Normally Open Relay Output (install diode provided)
GND (COM)	Negative Pole of Lock (Common Connection for Relay Output)
NC	Normally Closed Relay Output (Install diode provided)

## Sound and Light Indication

Operation Status	LED	Buzzer
Stand by	Red light bright	-
Enter into programming mode	Red light shines	One beep
In the programming mode	Orange light bright	One beep
Operation error	-	Three beeps
Exit from the programming mode	Red light bright	One beep
Open lock	Green light bright	One beep

## Connection Diagram

### Magnetic Lock or Fail-safe Lock

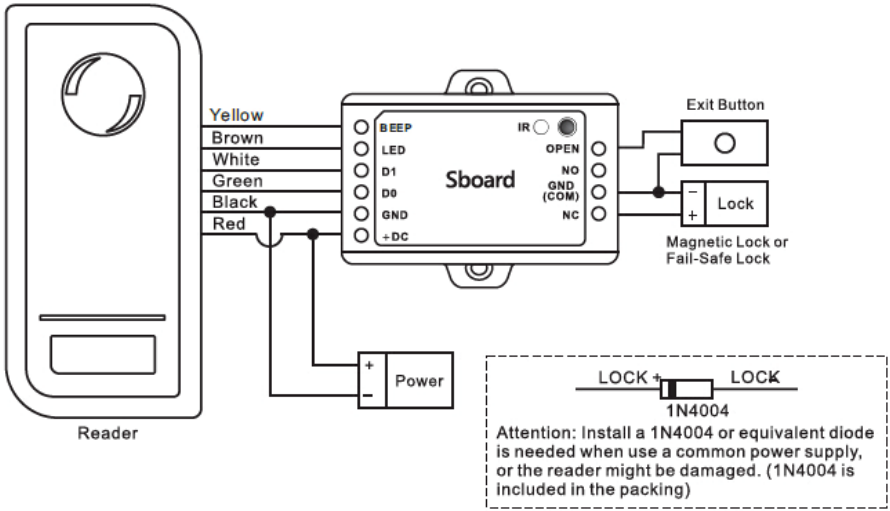

### Door/Gate Operator or Fail-secure Lock

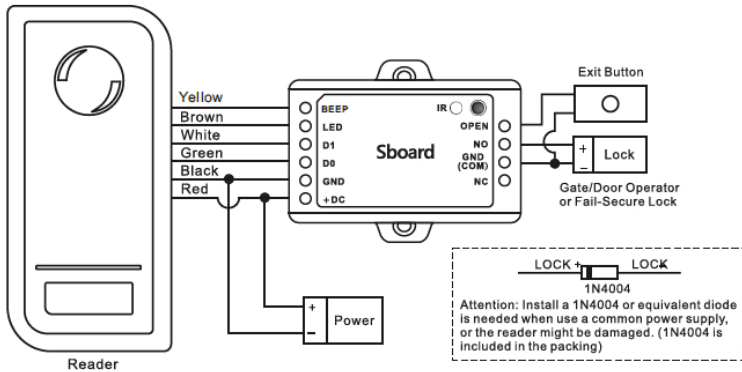

### When Use NO/NC/COM Dry Contact Output

- 1) Remove the Pin Caps on points 1, 2 and points 3, 4
- 2) Insert one of the Pin Caps on points 1, 3
- 3) Fix the back cover, and keep the other Pin Cap well

#### Remark:

The power supply's voltage must be the same with lock's supply voltage, or else, the lock will not work properly or be damaged.

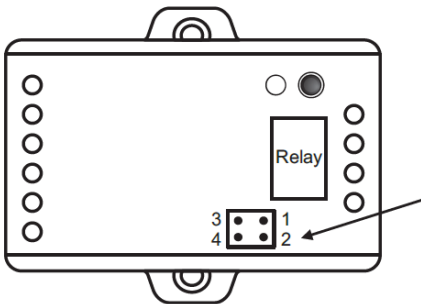

## Reset to Factory Default and Master Cards Programming

To reset to factory default, power off, press the Exit Button (or connect “OPEN” and “GND” to be short circuit), hold it and power on, there will be two beeps, and the LED light turns into orange, release the exit button (or disconnect “OPEN” and “GND”), then read any two cards on the external reader, the LED will turn into red, means reset to factory default successfully. Of the two cards reading, the 1 one is Master Add Card the 2 one is the Master Delete Card.

### Remarks:

- The Master Cards are not included in the standard packing. The type of the Master Card is according to the external reader. For example: the external reader is 125KHzHID Reader, then the Master Card must be 125KHz HID Cards.
- If no Master Cards added, must press the Exit Button for at least 10 seconds before release.
- Reset to factory default, the user's information is still retained.

## PROGRAMMING

Programming will vary depending on access configuration. Follow the instructions according to your access configuration.

### Notes:

- **Remote Control:** Please use the Infrared Remote Control to program the Pulse Mini. The “IR” on the Pulse Mini is the infrared receiving window, please direct the Remote Control to it.
- **User ID number:** Assign a user ID to the access card in order to track it. The commonuser ID number can be any number from 0~999.  
**IMPORTANT:** User IDs do not have to be proceeded with any leading zeros. Recording of User ID is crucial. Modifications to the user require the User ID be available.
- **PIN:** Can be any 4~6 digits except 8888 which is reserved.

### Enter and Exit Program mode

Programming Step	Keystroke Combination
1. Enter Program Mode	<b>(Master Code) #</b> (Factory default is 123456)
2. Exit Program Mode	*

## Set Master Code

Programming Step	Keystroke Combination
1. Enter Program Mode	* <b>(Master Code) #</b>
2. Update Master Code	<b>0 (New Master Code) # (Repeat New Master Code) #</b> (code: 6 digits)
3. Exit Program Mode	*

## Add Users with Remote Control

### Pulse Mini Connected with Card Reader:

For the readers develop together with Pulse Mini, such as S series readers, kip the below step 1; For other card readers, set the Pulse Mini's Wiegand input as below step 1 according to the Wiegand output of the readers.

### Pulse Mini Connected with Keypad Reader:

Can be any Keypad Reader with 4Bits, 8Bits (ASCII), 10Bits output format Set the Pulse Mini as below step 1 according to the Wiegand output and PIN output format of the Keypad Reader.

PIN(s) can be input/added on either the remote control or the external Keypad Reader, except when the Keypad Reader is 10 digits virtual card number ouput, the PIN(s) can only be input/added through the Keypad Reader.

## Step 1

Programming Step	Keystroke Combination
1. Enter Program Mode	* <b>(Master Code) #</b>
2. Wiegand Input bits PIN Input bits	<b>8 (26~37) #</b> (Factory default is 26bits) <b>8 (4 or 8 or 10) #</b> (Factory default is 4bits)
3. Exit Program Mode	*

Remarks: 4 means 4 bits, 8 means 8 bits, 10 means 10 digits virtual number.

## Step 2

Programming Step	Keystroke Combination
<b>Add Card User</b>	
1. Enter Program Mode	* <b>(Master Code) #</b>
2. Add Card: Using Auto ID (Allows Pulse Mini to assign Card next available User ID number) <b>OR</b> 2. Add Card: Select Specific ID (Allows Master to define a specific User ID to associate the card to) <b>OR</b> 2. Add Card (all 8 digits): by Card Number <b>OR</b> 2. Add Card (all 8 digits): Block Learn (Allows Master to add up to 1000 cards to the Reader in a single step.) Takes 2 minutes to program	<b>1 (Read Card on External Reader) #</b> Repeat Step 2 for additional user cards  <b>1 (User ID) # (Read Card on External Reader) #</b> The user ID is any number from 0-999  <b>1 (Input 8/10 digits Card number) #</b>  <b>1 (User ID number) # (Card quantity) #</b> <b>(The first card number) #</b> Cards' number must be consecutive; Card quantity = # of card to be enrolled
3. Exit Program Mode	*
<b>Add PIN User</b>	
1. Enter Program Mode	* <b>(Master Code) #</b>
2. Add PIN: Using Auto ID (Allows Pulse Mini to assign PIN to next available User ID number)	<b>1 (Input PIN) #</b> Repeat Step 2 for additional user cards (PIN: 4~6 digits)
2. Add PIN: Select Specific ID (Allows Master to define a specific User ID to associate the card to)	<b>1 (User ID) # (Input PIN) #</b> The user ID is any number from 0-999 (PIN: 4~6 digits)
3. Exit Program Mode	*



## Pulse Mini Connected with Fingerprint Reader:

For example:

Connect F1 as the fingerprint reader to Pulse Mini, two steps to enroll the valid fingerprint.

(1) Add the Fingerprint (A) on F1

(2) Add the same Fingerprint (A) on Pulse Mini as below:

1	Enter Program Mode: * <b>(Master Code) #</b>
2	<b>1 (Press Fingerprint A on F1) (Repeat Fingerprint A on F1) #</b> (ID auto allocated)
<b>OR</b>	
2	<b>1 (User ID) # (Press Fingerprint A on F1)</b> <b>(Repeat Fingerprint A on F1) #</b> (Select specific ID)
3	Exit: *

## Add Users by Master Add Card

Add card users

Master Add Card – Read User Card – Master Add Card (Cards can be added continuously)

Add PIN users

Master Add Card – Input PIN – Master Add Card (PINs can be added continuously)

## Change PIN

Programming Step	Keystroke Combination
<b>Note: Done outside programming mode, users can perform this themselves</b>	
1. Enter Program Mode	* <b>(Master Code) #</b>
1. Change the card associated PIN (There will auto associate PIN (8888) to cards when adding card users)	* <b>(Read Card) (Old PIN) #</b> <b>(New PIN) # (Repeat New PIN) #</b> (PIN: 4~6 digits)
1. Change the users' PIN	* <b>(ID Number) # (Old PIN) #</b> <b>(New PIN) # (Repeat New PIN) #</b> (PIN: 4~6 digits)
2. Exit Program Mode	*

### Delete User Card(s) or PIN(s) by Remote Control

Programming Step	Keystroke Combination
1. Enter Program Mode	* <b>(Master Code) #</b>
2. Delete User By User ID <b>OR</b> 2. Delete User – By Card <b>OR</b> 2. Delete User – By Card number <b>OR</b> 2. Delete User – By PIN <b>OR</b> 2. Delete All User	<b>2 (User ID ) #</b>  <b>2 (Read Card on External Reader) #</b>  <b>2 (Input 8/10 digits Card number) #</b>  <b>2 (Input PIN) #</b>  <b>2 (Mater Code) #</b>
3. Exit Program Mode	*

### Delete Users by Master Delete Card

Delete card users

Master Delete Card – Read Card – Master Delete Card (Cards can be deleted continuously)

Delete PIN users

Master Delete Card – Input PIN – Master Delete Card (PINs can be deleted continuously)

### Set Relay Configuration

The relay configuration sets the behavior of the output relay on activation.

Programming Step	Keystroke Combination
1. Enter Program Mode	* <b>(Master Code) #</b>
2. Pulse Mode <b>OR</b> 2. Toggle Mode	<b>3 (1~99) #</b> The relay time is 1~99 seconds. (1 is 50mS) (Factory default is 5 seconds) <b>3 0 #</b> Sets the relay to ON/OFF Toggle mode
3. Exit Program Mode	*

### Set Access Mode

Programming Step	Keystroke Combination
1. Enter Program Mode	* <b>(Master Code) #</b>
2. Card access <b>OR</b> 2. Card + PIN access <b>OR</b> 2. Card or PIN access <b>OR</b> 2. Multi cards/PINs access	<b>4 0 #</b>  <b>4 1 #</b>  <b>4 3 (Factory default)</b>  <b>4 3 (2~9) #</b>
3. Exit Program Mode	*

### Set Audible and Visual Response

Programming Step	Keystroke Combination	
1. Enter Program Mode	* <b>(Master Code) #</b>	
2. Control Sounds <b>OR</b> 2. Control LED	<b>OFF = 7 0 #</b>  <b>OFF = 7 4 #</b>	<b>ON = 7 1 #</b>  <b>ON = 7 5 #</b> (Factory defaults are ON)
3. Exit Program Mode	*	

### User Information Transfer

The Pulse Mini supports the User Information Transfer function, and the enrolled user(cards, PINs) can be transferred from one (let's name it Master Unit) to another(let's name it Accept Unit). Maximum 10pcs Accepts Units can be transferred once.

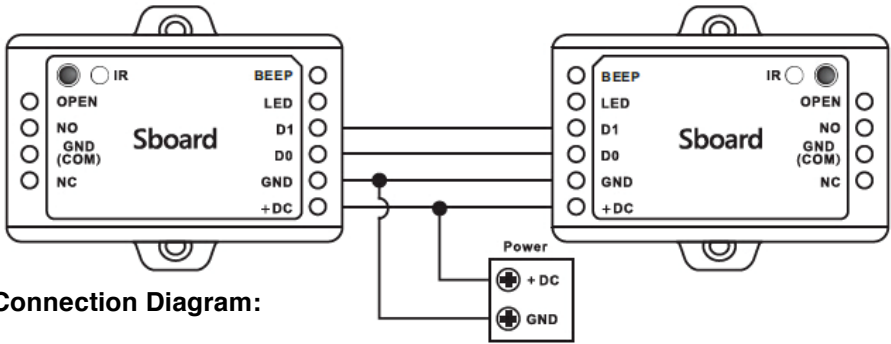

**Connection Diagram:**

**Remarks:**

The Master Units and Accept Units must be Pulse Mini or S1234 -X.  
 The Master Code of the Master Unit and the Accept Unit(s) must be set to the same.  
 Program the transfer operation on Master Unit only.  
 If the Accept Unit(s) are already with the users enrolled, it will be covered after transfer. For full 1,000 users enrolled, the transfer takes 3 minutes.

Programming Step	Keystroke Combination
1. Enter Program Mode	* <b>(Master Code)</b> #
2. Set transferring	<b>9 6 #</b>
Within 3 minutes, Green LED shines, that means the users' information has been transferred successfully.	
3. Exit Program Mode	*

## **WARRANTY**

The warranty period of Transmitter Solutions® Pulse Mini Receiver is 24 months. This warranty shall begin on the date the transmitter is manufactured. During the warranty period, the product will be repaired or replaced (at the sole discretion of Transmitter Solutions®) if the product does not operate correctly due to a defective component. This warranty does not extend to (a) the product case, which can be damaged by conditions outside the control of Transmitter Solutions®, or (b) battery life of the product. This warranty is further limited by the following disclaimer of warranty and liability:

EXCEPT AS SET FORTH ABOVE, TRANSMITTER SOLUTIONS® MAKES NO WARRANTIES REGARDING THE GOODS, EXPRESS OR IMPLIED, INCLUDING WARRANTY OF MERCHANTABILITY OR WARRANTY OF FITNESS FOR A PARTICULAR PURPOSE. BUYER MAKES NO RELIANCE ON ANY REPRESENTATION OF TRANSMITTER SOLUTIONS®, EXPRESS OR IMPLIED, WITH REGARD TO THE GOODS AND ACCEPTS THEM "AS-IS/WHERE-IS". TRANSMITTER SOLUTIONS® SELLS THE GOODS TO BUYER ON CONDITION THAT TRANSMITTER SOLUTIONS® WILL HAVE NO LIABILITY OF ANY KIND AS A RESULT OF THE SALE. BUYER AGREES THAT TRANSMITTER SOLUTIONS® SHALL HAVE NO LIABILITY FOR DAMAGES OF ANY KIND, WHETHER DIRECT, INCIDENTAL OR CONSEQUENTIAL DAMAGES, INCLUDING INJURIES TO PERSONS OR PROPERTY, TO BUYER, ITS EMPLOYEES OR AGENTS, AS A RESULT OF THE SALE. BUYER ALSO AGREES TO HOLD TRANSMITTER SOLUTIONS® HARMLESS FROM ANY CLAIMS BUYER, OR ANY THIRD PARTY, MAY HAVE AS A RESULT OF BUYER'S USE OR DISPOSAL OF THE GOODS. BUYER HAS READ THIS DISCLAIMER AND AGREES WITH ITS TERMS IN CONSIDERATION OF RECEIVING THE GOODS.



7380 S. Eastern Ave, Suite 124-320  
Las Vegas, NV 89123  
(866) 975-0101 • (866) 975-0404 fax  
[www.transmittersolutions.com](http://www.transmittersolutions.com)