

Tools required

- Phillips-head screwdriver
- Standard hex key set
- Standard box end wrench set
- Standard socket wrench set (with ½-inch extension)
- Torque wrench
- Hammer & punch

Installation Tips & Torques Specs

- Torque specifications must be adhered to or you will void the Limited Warranty.
- Tighten to 25 ft-lbs:
- ⅝ - 24 Nylock nuts (drive wheel)
- Tighten to 40 ft-lbs:
- Hex head bolt that secures the drive wheel to the motor shaft.

AdvanceDrive™ Wheels (6 and 8-inch)

1 Open the SlideDriver™ and Position Gate.

NOTE: *Unlock the cover, if necessary.*

1. Loosen the two Phillips-head screws at the base of the cover.
2. Lift the cover off the gate operator and set it aside.
3. Determine if the gate needs to be open for vehicular traffic while you're changing out the drive wheels. If it does, press the Open button to open the gate.



Turn OFF power to the SlideDriver and take the necessary precautions to avoid electrical shock.

2 Turn OFF power at the Control Box.



Do NOT grip the toggle handle when releasing the drive wheels inside the chassis! Take the necessary precautions and be careful as the mechanism is spring-loaded and drops rapidly. Keep your fingers above the handle. The spring produces a force of about 1800 psi onto the drive wheels. Slight downward pressure on the toggle handle causes the handle to drop rapidly. Keep your fingers, hands and tools clear of the area when the toggle handle deploys.

3 Release the Drive Wheels and disconnect the Hydraulic Hoses.

1. Remove the hydraulic hoses from the pump pack.
NOTE: *Have rags handy. Hydraulic fluid may drip from the hoses.*
2. Release the drive wheels by carefully lowering the Toggle Handle. Read the CAUTION note.

1 Open SlideDriver™ and Position Gate

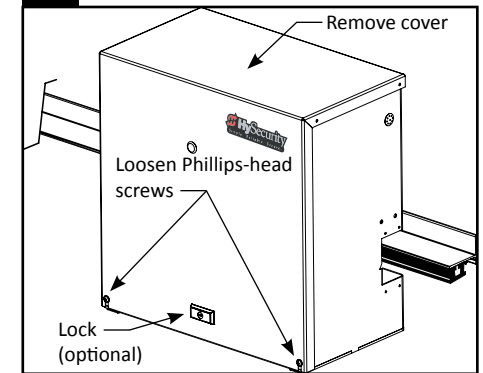

2 Turn off Power

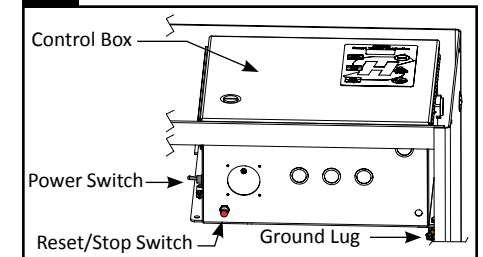

3 Release Drive Wheels and Disconnect Hoses

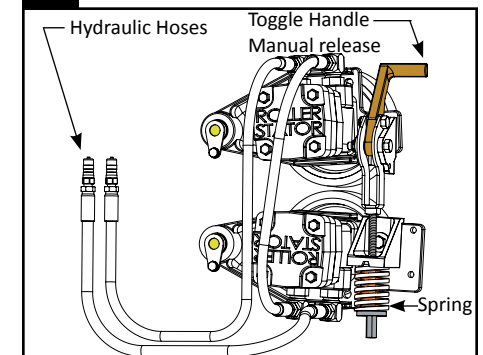

4 Remove the Drive Arm Motor Mount Assembly brackets.

1. Using a 7/16-inch box end wrench, loosen and remove the two bolts and washers that secure the pivot pins to the chassis bracket.

NOTE: It is easier to remove the upper drive arm motor mount first.

2. Turn the tabs on the pivot pins so they can be used as a handle.
3. Slide the pivot pins out of the chassis bracket while supporting the drive arm motor mount assembly. Place the entire assembly on a level workspace.

NOTE: Two access holes exist on the backside of the SlideDriver. You can use a punch and hammer if you need to break loose the pivot pins to slide the drive wheel assembly out.

5 Remove and Replace the Drive Wheels.

1. Using a 1/2-inch wrench or socket, loosen and remove the four Nylock nuts that secure the retaining plate and drive wheel to the wheel hub.
2. Discard the drive wheels, retaining plate and lock nuts. New Nylock nuts and a retaining plate are provided with the drive wheels.
3. Replace the new drive wheels and retaining plate onto the wheel hub. Secure using the bolts and washers removed in step 2. Tighten to 40 ft-lbs.
4. Secure each drive wheel with the 4 lock nuts provided. Tighten to 25 ft-lbs.



CAUTION

Use a torque wrench set to 25 ft-lbs to tighten the drive wheel fasteners (4 lock nuts). Twenty-five foot pounds is comparable to a 1/2 of a turn past snug. A torque wrench is the recommended tool. Use a torque wrench set between 30 and 40 ft-lbs to tighten the hex head bolt that secures the wheel hub to the motor mount. If the fasteners are not torqued properly, you will void the Limited Warranty.

continued...

4 Remove the Drive Arm Motor Mounts from the Chassis

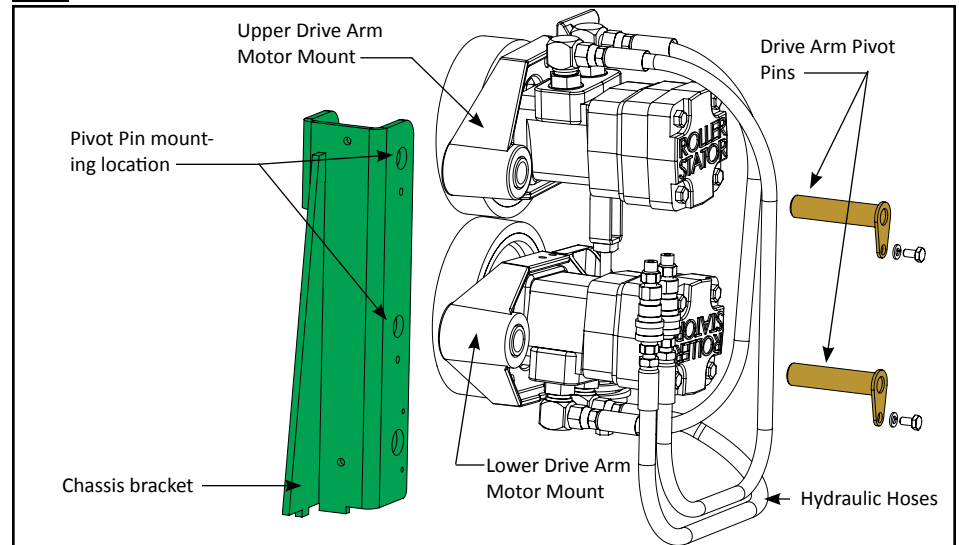

5 Remove/Replace the Drive Wheels

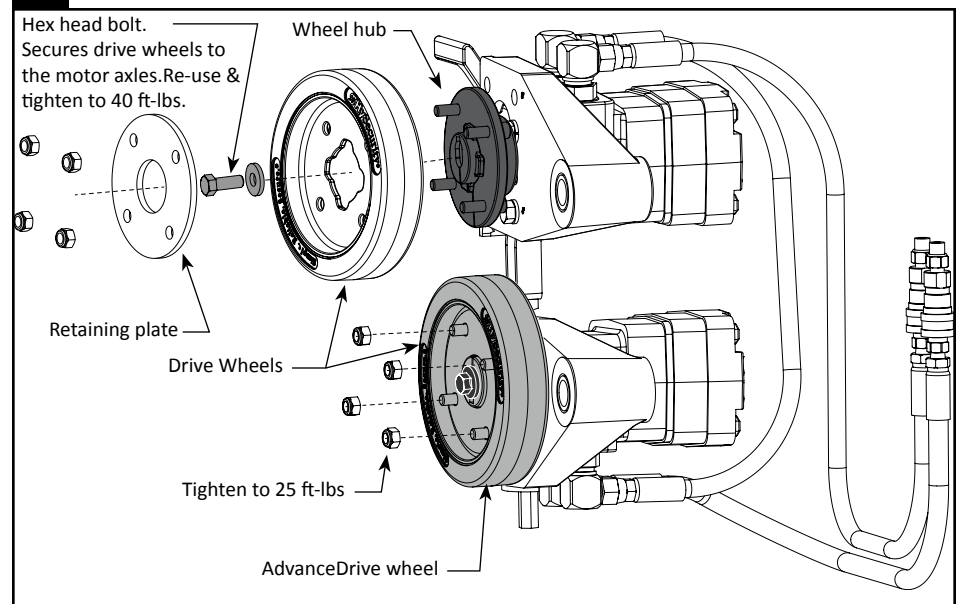

6 Reinstall the Drive Arm Motor Mounts onto the Chassis.

NOTE: Install the lower drive arm motor mount onto the chassis first.

1. Slide the Drive Arm Pivot Pins through the motor mounts and into the chassis bracket.
2. Turn the tabs down along the chassis and replace the washers and bolts removed in step 4.1.



When the drive arm motor mounts and AdvanceDrive Wheels are secured to the chassis, measure the compression spring at the base of the Toggle Handle. It's required length is 2-inches (5 cm) after the AdvanceDrive Wheels have been clamped onto the drive rail. To tension or loosen (expand or contract the length of) the compression spring, turn the adjusting nut at the base of the spring.

7 Check the compression spring and re-adjust, if necessary.

1. Measure the compression spring. When clamped, it should be 2-inches (5 cm) in height.
2. To expand or contract the length of the compression spring. Use a wrench to turn the adjusting nut at the base of the spring.
3. Reconnect the hydraulic hoses.
4. Turn on power at the Control Box.

Maintenance

For maintenance or troubleshooting issues, refer to the operator's product manual. If you do not have a copy of the manual, it is available on the the company website at www.hysecurity.com.

6 Reinstall the Drive Arm Motor Mounts onto the Chassis

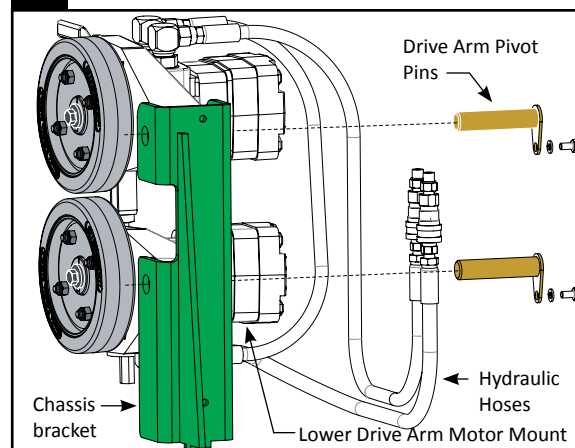

7 Check the Compression Spring and Connect Hoses

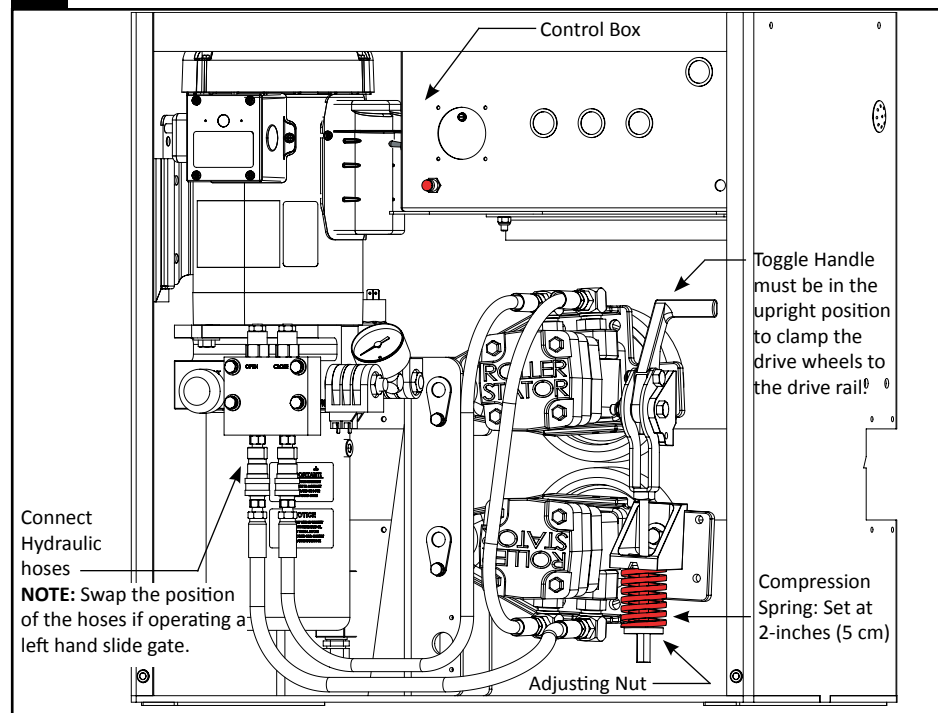



Technical Support

For Technical Support, call your installer or authorized HySecurity distributor. Obtain the serial number of your operator before calling. For the name of a distributor near you, call HySecurity at 800-321-9947.

For information about HySecurity training for installers, maintenance personnel and end users, refer to the company website at www.hysecurity.com.