

## MADCBB, MATDCBB, MASDCBB, & MASTDCBB HEAVY-DUTY DC BARRIER GATE OPERATOR

### OWNER'S MANUAL

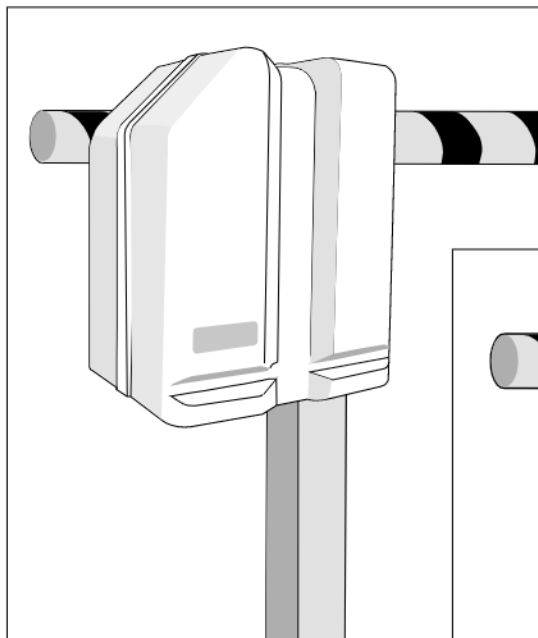

**MEGA ARM &  
MEGA SPRINT**

**MEGA ARM TOWER &  
MEGA SPRINT TOWER**

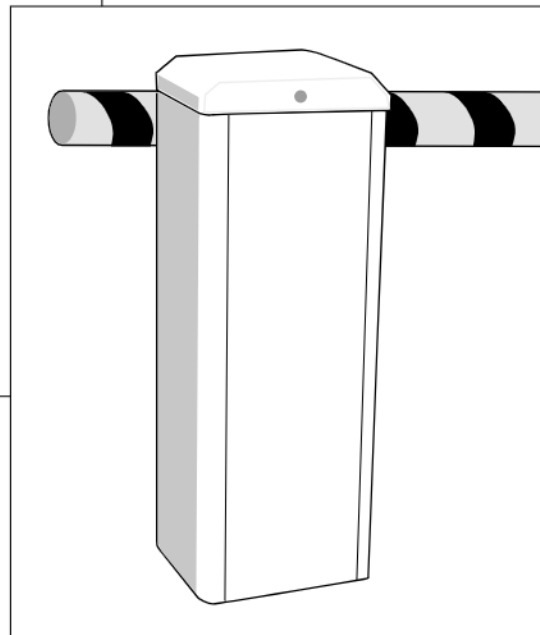

**IMPORTANT:** Read and understand Warranty Page first. Batteries (included) **MUST** be connected for proper operation of operator. Use (2) LiftMaster 12 Vdc 7AH (Part # MBAT).

# TABLE OF CONTENTS

## SAFETY

Safety Symbol and Signal Word Review	
UL325 Model Classifications	
Safety Installation Information	

## INTRODUCTION

Features	
Tools Needed	
Operator Specifications	

## INSTALLATION

Install the Concrete Pad and Conduit	
Attach the Operator to the Concrete Pad	
Install the Barrier Arm	

## WIRING

Power Wiring	
Input Commands Connections	
Accessory and Relay Connections	
Battery Installation	
Primary/Second Wiring	

## INSTALL THE RECEIVER

## FEATURES AND FUNCTIONS

S1 DIP Switches	
S2 DIP Switches	

## ADJUSTMENTS

Instant Reverse Device (IRD)	
Adjust the Barrier Arm	

## 2-4 OPERATION AND MAINTENANCE

2	Important Safety Instructions	15
3	General Service	16
4	Shear Pin Replacement	16
	Battery	16

## 5

## 5 ADDITIONAL FEATURES

5	Suggested Loop Sensor Locations	17
5	Trap Instructions	18
	Sequence Access Management System (SAMS) with "Memory"	19
6-7	Control Board Layout	20

## 6

## 7 TROUBLESHOOTING

7	Battery Checkout	21
	Gate Not Operating	21
8-11	Troubleshooting Chart	21

## 8

## 9 REPAIR PARTS

10	Part Numbers and Descriptions	22
10	Parts Shipped	22
11	Mega Arm Tower Unique Parts List	22
	Mega Arm Options Parts List	22

## 12

## ACCESSORIES

## 13-14

## WARRANTY POLICY

## 13

## 14

## 15

## 15

## 15

## SAFETY » SAFETY SYMBOL AND SIGNAL WORD REVIEW

When you see these Safety Symbols and Signal Words on the following pages, they will alert you to the possibility of **serious injury** or **death** if you do not comply with the warnings that accompany them. The hazard may come from something mechanical or from electric shock. Read the warnings carefully.

When you see this Signal Word on the following pages, it will alert you to the possibility of damage to your gate and/or the gate operator if you do not comply with the cautionary statements that accompany it. Read them carefully.

### IMPORTANT NOTE:

- **BEFORE attempting to install, operate or maintain the operator, you must read and fully understand this manual and follow all safety instructions.**
- **DO NOT attempt repair or service of your commercial door and gate operator unless you are an Authorized Service Technician.**



**WARNING**

MECHANICAL



**WARNING**

ELECTRICAL

**CAUTION**



**WARNING:** This product can expose you to chemicals including lead, which are known to the State of California to cause cancer or birth defects or other reproductive harm. For more information go to [www.P65Warnings.ca.gov](http://www.P65Warnings.ca.gov)

# SAFETY » UL325 MODEL CLASSIFICATIONS

## UL325 MODEL CLASSIFICATIONS

### CLASS I – RESIDENTIAL VEHICULAR GATE OPERATOR

A vehicular gate operator (or system) intended for use in a home of one-to four single family dwellings, or a garage or parking area associated therewith.



### CLASS II – COMMERCIAL/GENERAL ACCESS VEHICULAR GATE OPERATOR

A vehicular gate operator (or system) intended for use in a commercial location or building such as a multi-family housing unit (five or more single family units) hotel, garage, retail store or other building servicing the general public.



### CLASS III – INDUSTRIAL/LIMITED ACCESS VEHICULAR GATE OPERATOR

A vehicular gate operator (or system) intended for use in an industrial location or building such as a factory or loading dock area or other location not intended to service the general public.

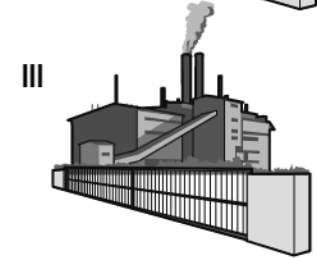

### CLASS IV – RESTRICTED ACCESS VEHICULAR GATE OPERATOR

A vehicular gate operator (or system) intended for use in a guarded industrial location or building such as an airport security area or other restricted access locations not servicing the general public, in which unauthorized access is prevented via supervision by security personnel.



## SAFETY ACCESSORY SELECTION

All UL325 compliant LiftMaster gate operators will accept external entrapment protection devices to protect people from motorized gate systems. UL325 requires that the type of entrapment protection correctly matches each gate application. Below are the six types of entrapment protection systems recognized by UL325 for use on this operator.

## ENTRAPMENT PROTECTION TYPES

- Type A: Inherent obstruction sensing system, self-contained within the operator. This system must sense and initiate the reverse of the gate within two seconds of contact with a solid object.
- Type B1: Connections provided for a non-contact device, such as a photoelectric eye can be used as a secondary protection.
- Type B2: Connections provided for a contact sensor. A contact device such as a gate edge can be used for secondary protection.
- Type C: Inherent adjustable clutch or pressure relief valve.
- Type D: Connections provided for a control requiring continuous pressure to operate the operator open and close.
- Type E: Built-in audio alarm. Examples include sirens, horns or buzzers.

**NOTE:** UL requires that all installations must have warning signs placed in plain view on both sides of the gate to warn pedestrians of the dangers of motorized gate systems.



## UL325 ENTRAPMENT PROTECTION REQUIREMENTS

GATE OPERATOR ENTRAPMENT PROTECTION				
UL325 Installation Class	Slide Gate Operator		Swing & Gate Barrier (Arm) Operator	
	Primary Type	Secondary Type	Primary Type	Secondary Type
Class I & II	A	B1, B2 or D	A or C	A, B1, B2, or C
Class III	A, B1 or B2	A, B1, B2, D or E	A, B1, B2 or C	A, B1, B2, C, D or E
Class IV	A, B1, B2 or D	A, B1, B2, D or E	A, B1, B2, C or D	A, B1, B2, C, D or E

The chart above illustrates the entrapment protection requirements for each of the four UL325 classes.

In order to complete a proper installation you must satisfy the entrapment protection chart shown above. That means that the installation must have one primary means of entrapment protection and one independent secondary means of entrapment protection. Both primary and secondary entrapment protection methods must be designed, arranged or configured to protect against entrapments in both the open and close directions of gate travel.

**For Example:** For a slide gate system that is installed on a single-family residence (UL325 Class I) you must provide the following: As your primary type of entrapment protection you must provide Type A inherent (built into the operator) entrapment sensing and at least one of the following as your secondary entrapment protection: Type B1- Non-contact sensors such as photoelectric eyes, Type B2- Contact sensors such as gate edges or Type D- Constant pressure control.

# SAFETY » SAFETY INSTALLATION INFORMATION

1. Vehicular gate systems provide convenience and security. Gate systems are comprised of many component parts. The gate operator is only one component. Each gate system is specifically designed for an individual application.
2. Gate operating system designers, installers and users must take into account the possible hazards associated with each individual application. Improperly designed, installed or maintained systems can create risks for the user as well as the bystander. Gate systems design and installation must reduce public exposure to potential hazards.
3. A gate operator can create high levels of force in its function as a component part of a gate system. Therefore, safety features must be incorporated into every design. Specific safety features include:
  - Gate Edges
  - Guards for Exposed Rollers
  - Photoelectric Sensors
  - Screen Mesh
  - Vertical Posts
  - Instructional and Precautionary Signage
4. Install the gate operator only when:
  - a. The operator is appropriate for the construction and the usage class of the gate.
  - b. All openings of a horizontal slide gate are guarded or screened from the bottom of the gate to a minimum of 4' (1.2 m) above the ground to prevent a 2-1/4" (6 cm) diameter sphere from passing through the openings anywhere in the gate, and in that portion of the adjacent fence that the gate covers in the open position.
  - c. All exposed pinch points are eliminated or guarded, and guarding is supplied for exposed rollers.
5. The operator is intended for installation only on gates used for vehicles. Pedestrians must be supplied with a separate access opening. The pedestrian access opening shall be designed to promote pedestrian usage. Locate the gate such that persons will not come in contact with the vehicular gate during the entire path of travel of the vehicular gate.
6. The gate must be installed in a location so that enough clearance is supplied between the gate and adjacent structures when opening and closing to reduce the risk of entrapment. Swinging gates shall not open into public access areas.
7. The gate must be properly installed and work freely in both directions prior to the installation of the gate operator.
8. Controls intended for user activation must be located at least six feet (6') away from any moving part of the gate and where the user is prevented from reaching over, under, around or through the gate to operate the controls. Outdoor or easily accessible controls shall have a security feature to prevent unauthorized use.
9. The Stop and/or Reset (if provided separately) must be located in the line-of-sight of the gate. Activation of the reset control shall not cause the operator to start.
10. A minimum of two (2) WARNING SIGNS shall be installed, one on each side of the gate where easily visible.
11. For a gate operator utilizing a non-contact sensor:
  - a. Reference owner's manual regarding placement of non-contact sensor for each type of application.
  - b. Care shall be exercised to reduce the risk of nuisance tripping, such as when a vehicle trips the sensor while the gate is still moving.
  - c. One or more non-contact sensors shall be located where the risk of entrapment or obstruction exists, such as the perimeter reachable by a moving gate or barrier.
12. For a gate operator utilizing a contact sensor such as an edge sensor:
  - a. One or more contact sensors shall be located where the risk of entrapment or obstruction exists, such as at the leading edge, trailing edge and post mounted both inside and outside of a vehicular horizontal slide gate.
  - b. One or more contact sensors shall be located at the bottom edge of a vehicular vertical lift gate.
  - c. A hard wired contact sensor shall be located and its wiring arranged so the communication between the sensor and the gate operator is not subject to mechanical damage.
  - d. A wireless contact sensor such as the one that transmits radio frequency (RF) signals to the gate operator for entrapment protection functions shall be located where the transmission of the signals are not obstructed or impeded by building structures, natural landscaping or similar obstruction. A wireless contact sensor shall function under the intended end-use conditions.
  - e. One or more contact sensors shall be located on the inside and outside leading edge of a swing gate. Additionally, if the bottom edge of a swing gate is greater than 6" (152 mm) above the ground at any point in its arc of travel, one or more contact sensors shall be located on the bottom edge.
  - f. One or more contact sensors shall be located at the bottom edge of a vertical barrier (arm).

# INTRODUCTION » FEATURES + TOOLS NEEDED + OPERATOR SPECIFICATIONS

## FEATURES

- Full service controller with eight inputs and LED indicators for loops, card reader, radio, etc.
- Reversible arm direction for right or left handed operation.
- Instant Reverse Device (IRD) monitor senses obstructions during motion.
- Fail safe (auto open on AC power failure).
- Raise gate input memory will memorize multiple vehicles – ideal for bar code scanners and AVI.
- Ability to STOP arm in close travel if tail-gating is sensed at close loop.
- Anti-tail gate alarm - fires K1 relay to trigger a warning device when tail-gating is sensed.
- SAMS with “memory” - allows Mega Arm to open a slide/swing gate first then raises arm.
- Dynamic motor braking to preserve arm positioning.
- Direct drive gear reducer eliminates many parts that might otherwise fail.
- State of the art MOSFET motor drive technology, NO contactors or relays.
- Soft start and stop in open and close travel motions.
- No limit switches to fail - uses magnetic (Hall Effect) sensors to monitor arm position.
- Maximum Run Timer for motor with anti-tamper protection in closing direction.
- Each operator configurable as primary or second operator.
- LED diagnostics for easy troubleshooting.
- Adjustable Timer-To-Close with on/off selection.
- Transient voltage protection on all inputs.

## TOOLS NEEDED

During assembly, installation, and adjustment of the operator, the tools listed below may be needed.

- Wrench or Socket Set
- Phillips Head Screwdriver
- C Clamps
- Level
- Small Screwdriver
- T25 Torx Head Screwdriver

## OPERATOR SPECIFICATIONS

This model is intended for use in vehicular gate applications.

- High torque 24 volt Permanent Magnet DC motor
- On 120 Vac installations, unswitched duplex outlet gives convenient supply for 120 Vac accessories
- Built in battery run - inherent 24 Vdc backup power with regulated 24 Vdc for accessories
- Capable of being powered from 120 or 230 Vac, or UL Listed Class 2 Solar Power
- Break away mount design for the 12-15 foot x 3 inch tubular aluminum barrier arm
- Heater option MUST be used if temperature is 30° or below. Heater option available for 120 Vac operators ONLY. Refer to Accessories page.
- All rust proof aluminum construction with white powder coat baked on enamel. Molded Polyethylene UV stabilized cover never needs wax or paint (excludes towers).

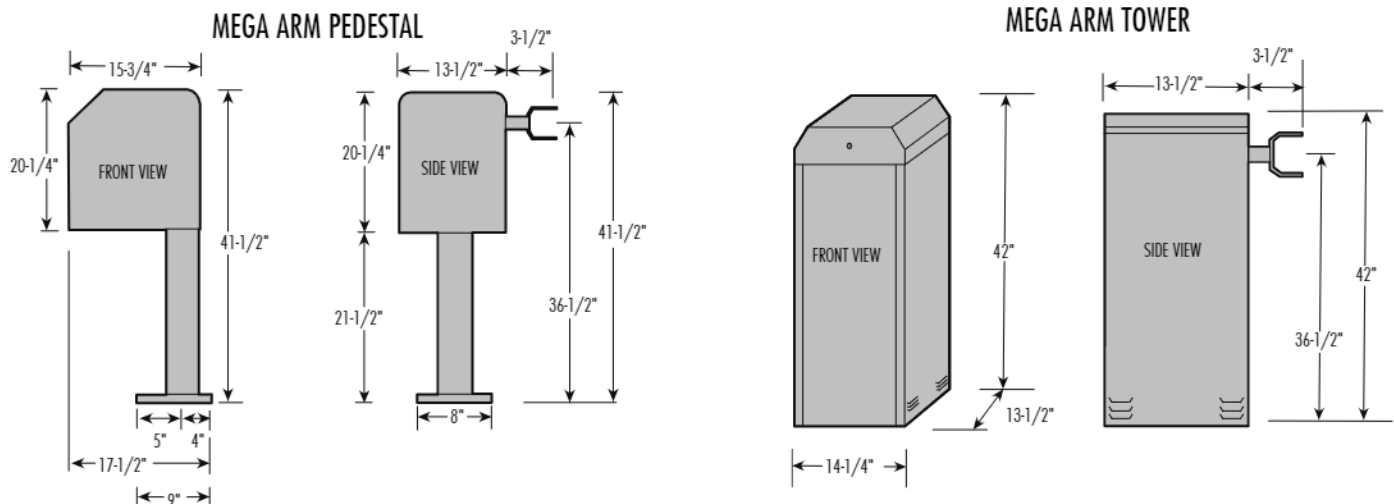

# INSTALLATION » INSTALL THE CONCRETE PAD AND CONDUIT

## INSTALL THE CONCRETE PAD AND CONDUIT

Check the national and local building codes before installation.

**1** **Layout the concrete pad for the operator.** The concrete pad should be approximately 24" x 24" x 24" in order to ensure proper and stable operation. The pad should be 6" above the finished grade or even with top of curb (if applicable). **NOTE:** Pad should always extend below frost line in regions where ground will freeze.

**2** **Install the conduit.** The conduits should be installed to fit the 3-1/2" x 3-1/2" opening in the pedestal base plate or the 10-1/4" x 8-1/4" opening in the tower base plate. The operator should be centered on the pad and spaced approximately 6" from the edge of the pad on drive way side (in order to get the most reach out of arm). Install conduits for the 120/230 Vac main power, low voltage control wiring, and one or two extra for loop sensor leads. Conduit size should be limited to 1/2" when possible to reduce crowding if more than four are needed. All conduits must be UL approved.

**3** **Pour a concrete pad (reinforced concrete is recommended).**

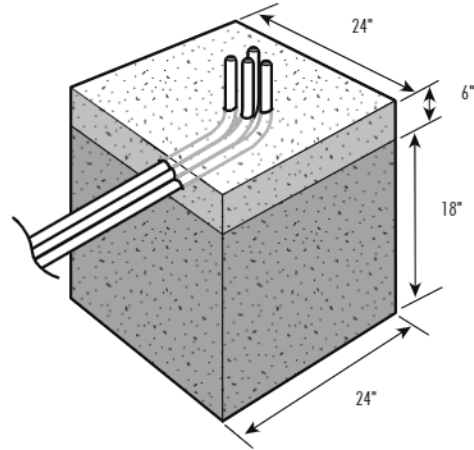

TOP VIEW OF PEDESTAL FOOTPRINT

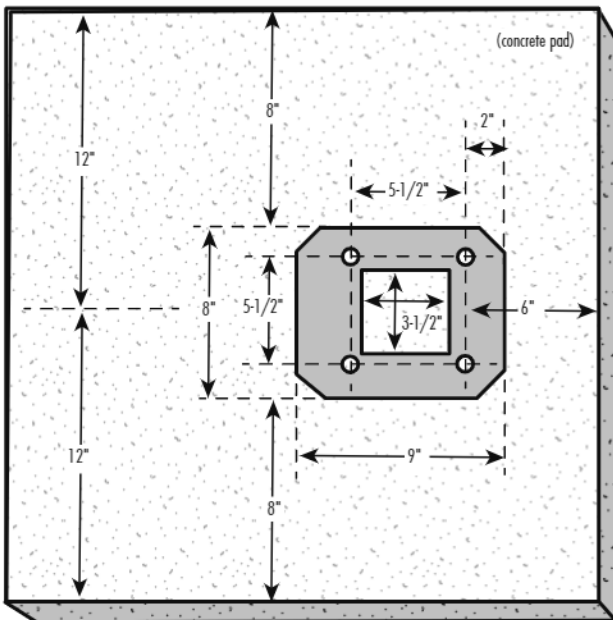

TOP VIEW OF TOWER FOOTPRINT

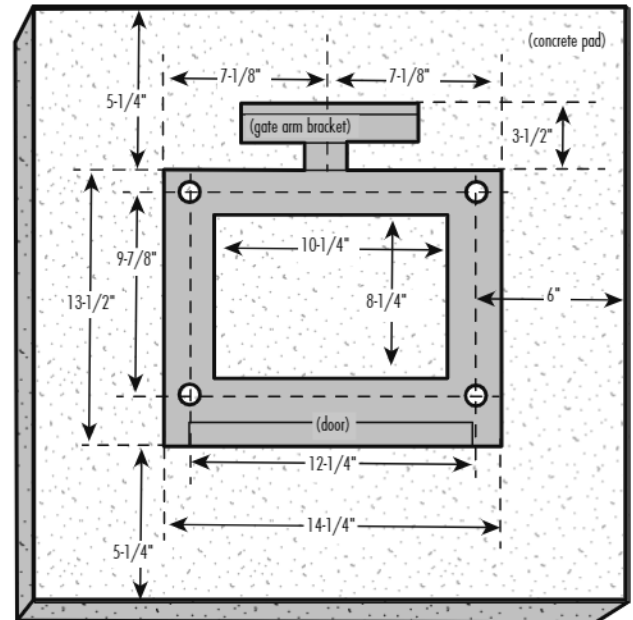

# INSTALLATION » ATTACH THE OPERATOR TO THE CONCRETE PAD

## ATTACH THE OPERATOR TO THE CONCRETE PAD

- 1 Position the operator on the concrete pad and mark the mounting holes.
- 2 Install 1/2" x 6" wedge anchors in the location of the mounting holes. The wedge anchors should be installed with approximately 1-1/4" showing above the concrete pad in order to allow for the 1/2" thick base plate as well as washers for leveling.
- 3 Attach the operator to the concrete pad with appropriate fasteners.

PEDESTAL INSTALLATION

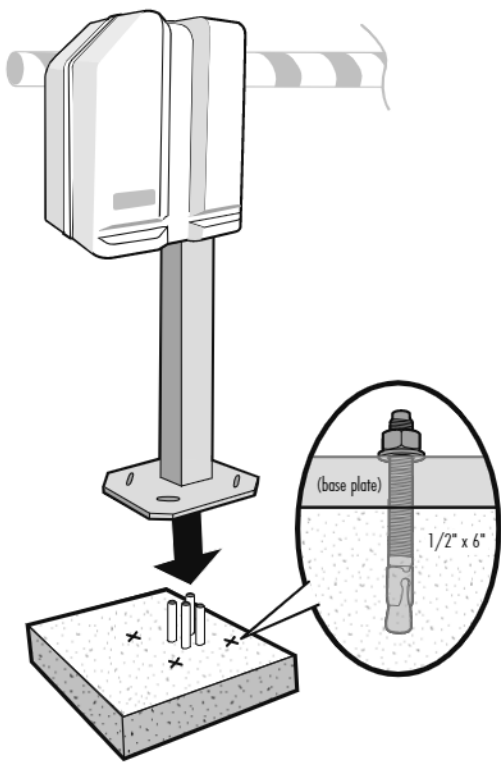

TOWER INSTALLATION

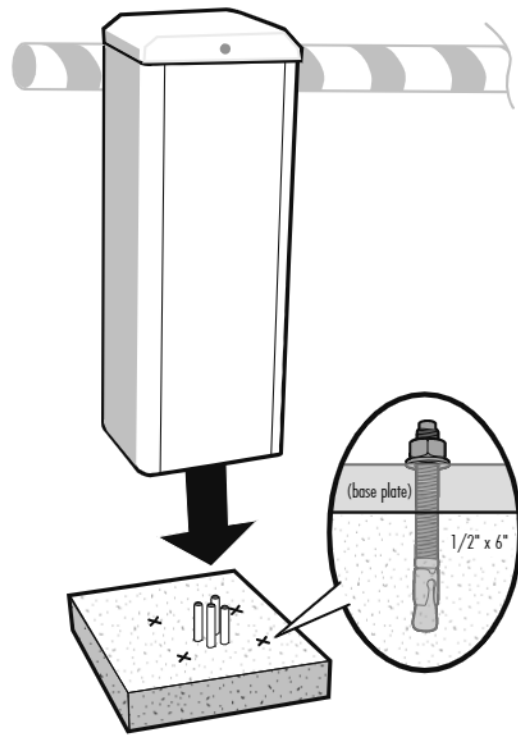

## INSTALL THE BARRIER ARM

- 1 Line up the holes in the barrier arm with the slotted holes in gate arm bracket.
- 2 Insert the bolts through the barrier arm and gate arm bracket.
- 3 Secure with the flat washers and nylon nuts (It is recommended to use ONLY nylon nuts).

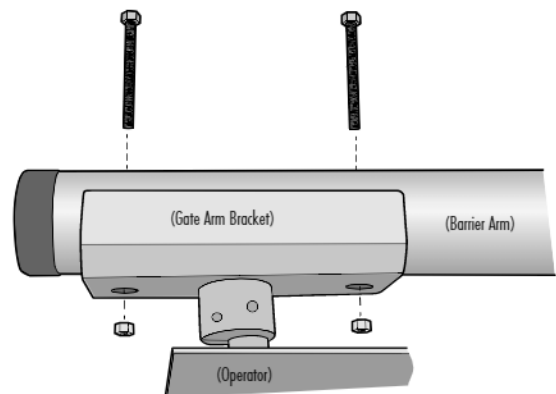

# WIRING » POWER WIRING

## WARNING

To reduce the risk of SEVERE INJURY or DEATH:

- ANY maintenance to the operator or in the area near the operator MUST NOT be performed until disconnecting the electrical power and locking-out the power via the operator power switch. Upon completion of maintenance the area MUST be cleared and secured, at that time the operator may be returned to service.
- Disconnect power at the fuse box BEFORE proceeding. Operator MUST be properly grounded and connected in accordance with local electrical codes.  
**NOTE:** The operator should be on a separate fused line of adequate capacity.
- ALL electrical connections MUST be made by a qualified individual.
- DO NOT install any wiring or attempt to run the operator without consulting the wiring diagram. We recommend that you install an optional reversing edge BEFORE proceeding with the control station installation.
- ALL power wiring should be on a dedicated circuit and well protected. The location of the power disconnect should be visible and clearly labeled.
- ALL power and control wiring MUST be run in separate conduit.
- BEFORE installing power wiring or control stations be sure to follow ALL specifications and warnings described below. Failure to do so may result in SEVERE INJURY to persons and/or damage to operator.

## POWER WIRING

Use UL approved 14AWG (or larger) 600 volt insulated wire only.

**NOTE:** Do not connect the batteries until instructed.

### 120 VAC

- 1 Ensure your main power is OFF before connecting the AC power.
- 2 The AC wiring should be connected to the wires exiting the conduit or pedestal post. Connect AC power to the operator:
  - Connect the black wire to the incoming 120 Vac hot lead.
  - Connect the white wire to the incoming neutral lead.
  - Connect the green wire to the ground.
- 3 Do not connect any of the AC power wires directly to the control board.

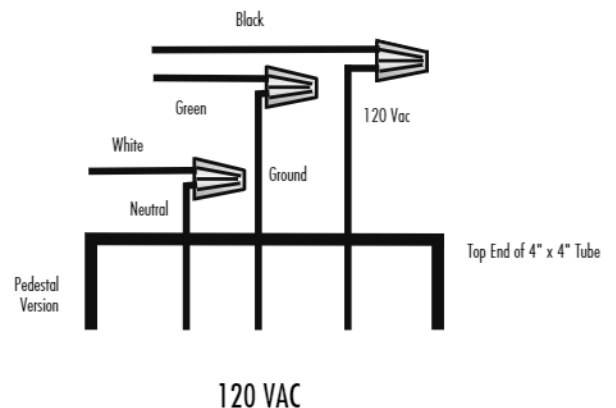

### 230 VAC

The 120 to 230 Vac conversion kit will need to be purchased for 230 Vac operation. See Accessories page.



# WIRING » INPUTS

## INPUTS (J5 TERMINAL STRIP)

### CAUTION

DO NOT connect ANY device which would deliver ANY voltage of ANY kind to these terminals.

The J5 terminal strip is used for controlling the barrier arm with various accessories such as receivers, loop detectors, access controls, and push button stations. Use common and normally open contacts from devices connected to these inputs. The J5 terminal strip is located on the top of the control board. Make connections to the appropriate points for the desired operation. Wires should be UL approved 600 volt rated and at least 18 AWG. They are to be routed through the upper grommet in chassis to avoid chafing. All external control devices must have normally open dry contacts.

TERMINAL	INPUT	EXPLANATION
1,2,3	OPEN	These inputs will trigger gate open when pulsed or hold gate open with maintained contact. When released gate will close if closing timer is on or if close input is given.
4	AUXILIARY OPEN	Same as 1, 2 and 3 with S2 switch 6 off. With S2-6 DIP switch in the ON position, the Multiple Vehicle Memory will activate, with inputs on terminal 4 and Common (COM) on the J5 terminal strip. Use with laser scanners or card readers and (transmitters with timed anti-pass back). With S1 switch 5 on, this input becomes a momentary <b>pulse open, pulse close</b> .
5	SAFETY	This input is generally not used with the MEGA ARM. If used its function is to make gate reverse and go back to the open position if it was closing. Input is disabled when gate is closed.
6	CLOSE	When used with a vehicle detector, it is recommended that the presence contacts (N.O. & C.) be used for the close input. This input will close gate after input is applied and then removed. It will stop the open cycle and reverse gate to close. <b>EXAMPLE:</b> Car crosses over close loop before arm reaches full open position- gate will reverse and close. <b>NOTE:</b> The close input also acts as a safety-stop in that if gate is closing and a tailgater is sensed at the close input, the gate WILL STOP its closing motion and not continue to close until the close input is removed or gate is re-opened.
7	BACK-AWAY (FREE EXIT)	This input is used as a free exit input to open gate. When input is active, gate will open and close immediately once input is removed. <b>EXAMPLE:</b> Car pulls up to exit loop, gate opens; car "backs-away" from exit loop and gate closes.
8	SHADOW (SAMS)	Used to monitor an auxiliary open limit switch of another operator in the same lane. SAMS with memory feature, see page 19.
9,10,11,12	COMMON	These are the commons (0 Vdc) to be used to activate above inputs.

**NOTE:** Above inputs are tied to LED indicators to show input command activity.

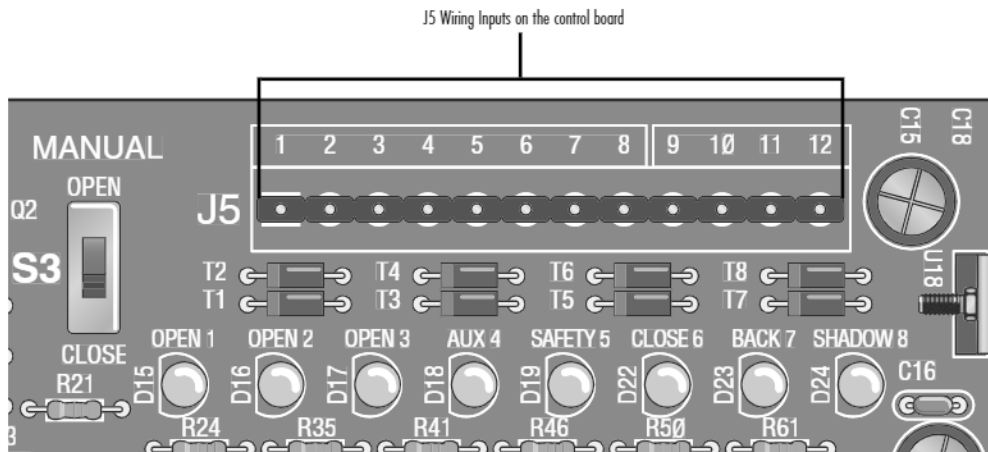

# WIRING » ACCESSORY AND RELAY CONNECTIONS + BATTERY INSTALLATION

## ACCESSORY AND RELAY CONNECTIONS

These terminals will provide battery backed power to 24 Vdc devices and are located at the bottom of the control board at J4 terminals 1 and 2. Terminal 1 is 24 Vdc (+) and number 2 is 0 Vdc (-). Peripheral CLASS 2 low voltage devices that require 24 Vdc power maybe connected here (500 ma. maximum).

**EXAMPLE:** Vehicle detector, radio receiver.

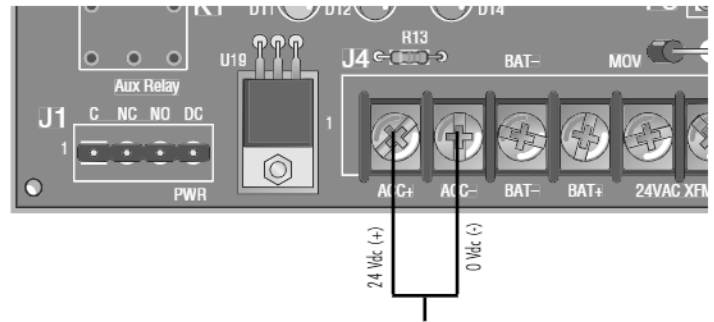

The K1 Relay (optional) and terminal strip (J1) are used for auxiliary devices such as Counters, Alarms, Buzzers, and SAMS (Sequence Access Management System).

### RELAY OUTPUT K1 - (OPTIONAL)

S1-6	S1-8	RESULT
OFF	OFF	Relay will fire (latch) when gate is not closed.
ON	OFF	Relay will fire when arm is pushed up off of limit switch (use with slip clutch option) and fires relay when a tail-gate is detected by the close loop - ANTI TAIL-GATE ALARM.
OFF	ON	Relay will pulse relay when arm reaches full open position.
ON	ON	Relay will only pulse when input is given to J5 1,2,3 inputs. (Refer to pages 14-15.)

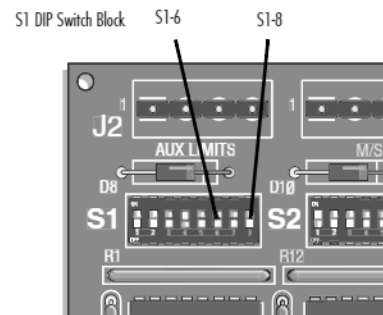

## BATTERY INSTALLATION

CONNECTING THE BATTERY LEADS - ALWAYS CONNECT AC POWER BEFORE INSTALLING BATTERIES.

- 1 Connect AC power BEFORE installing batteries.
- 2 Install two new, fully charged 12 volt DC batteries on shelf next to motor.
- 3 Connect red lead from the operator control board to the positive (RED +) terminal of one battery.
- 4 Connect the black lead from the operator control board to the (BLACK -) terminal of the OTHER battery.
- 5 Connect the jumper (provided) between the remaining terminals of each battery if one is not already in place.

**IMPORTANT:** Do not run operator without installing the batteries.

Replace batteries in pairs using LiftMaster MBAT or 29-NP712 batteries. Failure to install batteries correctly will cause damage and will not be covered by warranty.

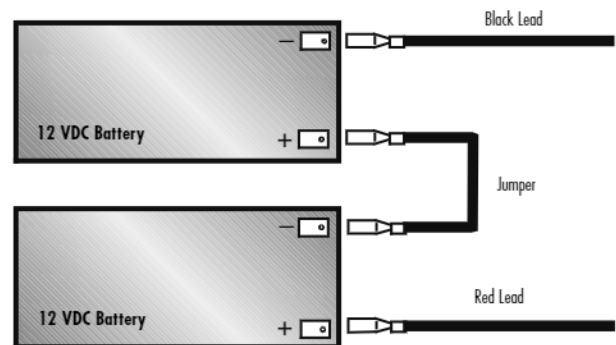

# WIRING » PRIMARY/SECOND WIRING

## PRIMARY/SECOND WIRING

In a primary/second configuration, either operator can be the primary.

- 1 Choose an operator to be the primary and then direct all control wiring to it (also install vehicle detectors and receivers in it).
- 2 At the primary, any input (at J5) with control wires (detectors, receivers, keypads, timers, etc.) to it must also be run to the same terminals of the second. Along with these control wires, both operators **MUST** share a common ground connection from chassis to chassis (or from common to common, i.e., primary gate J5 terminal #12 to second gate J5 terminal #12).  
**EXAMPLE:** If only open and close are used at primary then three wires will run between gates (Figure 1).
- 3 If it is required that if one gate senses an obstruction, the other reverses also, then 3 additional wires must be run between the primary J3 and second J3 (Figure 2). These connections are for transmitting IRD (obstruction signals) between both operators. This will allow the primary or second to inform the other that a closing obstruction has occurred and for it to reverse and open. **SET** switches on S2, 1-8 the same on both gates.

FIGURE 1

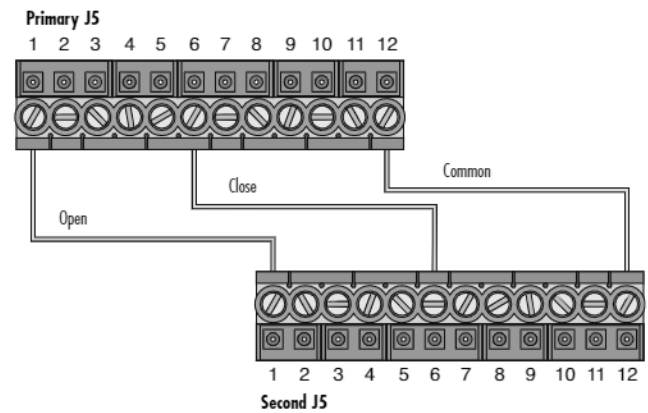
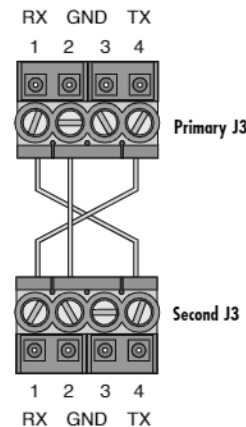

FIGURE 2



**IRD - Obstruction Signal Connections**  
 Terminal 1 of Primary must go to terminal 4 of Second and terminal 1 of Second must go to terminal 4 of Primary. Terminal 2 of Primary must go to terminal 2 of Second.

# INSTALL THE RECEIVER » INSTALL THE RECEIVER

## ⚠ WARNING

To prevent possible **SERIOUS INJURY** or **DEATH** from a moving gate or garage door:

- ALWAYS keep remote controls out of reach of children. NEVER permit children to operate, or play with remote control transmitters.
- Activate gate or door ONLY when it can be seen clearly, is properly adjusted, and there are no obstructions to door travel.
- ALWAYS keep gate or garage door in sight until completely closed. NEVER permit anyone to cross path of moving gate or door.

## INSTALL THE RECEIVER

### WIRING THE RECEIVER

Contacts 1 and 2 on the receiver terminal strip are for power. The power terminals are unpolarized. Connect terminals 1 and 2 to the accessory power terminals on the J4 terminal strip at the bottom of the control board (Figure 1).

Contacts 3 and 4 on the receiver terminal strip are for a common and a relay. Connect terminals 3 and 4 to terminals 1 and 10 on the J5 terminal strip at the top of the control board.

**NOTE:** Auxiliary Pin 4 can be used for push to open/push to close functionality.

### SET SECURITY MODE

The Universal Receiver can be used with up to 15 rolling code remotes or passwords in HIGH security mode. Alternately, it can be used with up to 31 of any type remote in NORMAL security mode, including any combination of rolling code, billion code (390 MHz only), or dip switch remotes.

The jumper must be set at the HIGH position for the receiver to operate in HIGH security mode. It must be set at NORMAL position to operate at the NORMAL mode (Figure 2).

When changing from NORMAL to HIGH security mode, any previous remote codes must be erased. Repeat Steps 2 and 3 in the Programming Section below to reprogram the receiver for each remote control in use.

The receiver is factory set at HIGH.

### PROGRAMMING THE REMOTE TO THE RECEIVER

- 1 Pry open the front panel of receiver case with a coin or a screwdriver. Re-connect power to opener (Figure 3).
- 2 Press and release the "learn" button on the receiver. The learn indicator light will glow steadily for 30 seconds.
- 3 Within 30 seconds, press and hold the button on the hand-held remote that you wish to operate your gate.

The operator will now operate when the push button on either the receiver or the remote control is pressed.

Repeat Steps 2 and 3 for each remote control that will be used to operate the gate.

### TO ERASE ALL REMOTE CONTROL CODES

- 1 Press and hold the "learn" button on the receiver panel until the indicator light turns off (about 6 seconds). All remote codes are now erased.

Follow the steps above to reprogram each remote control.

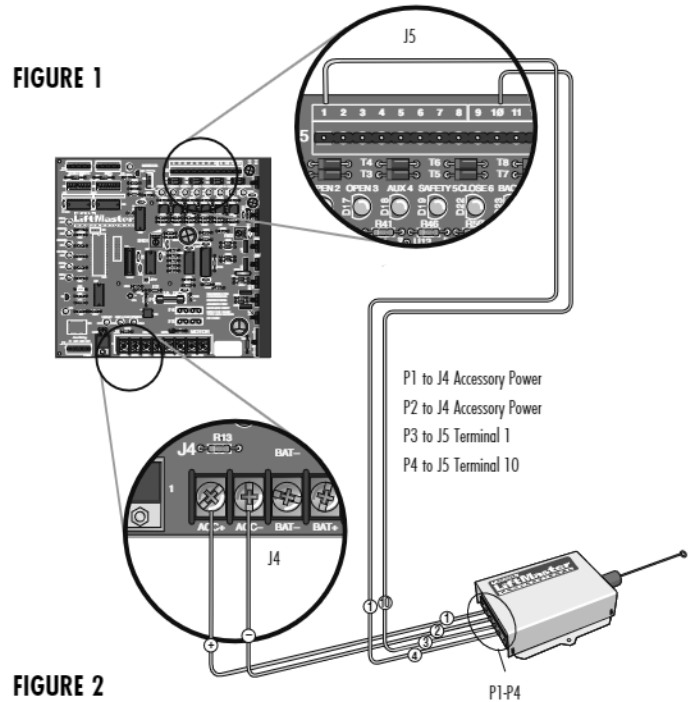

FIGURE 1

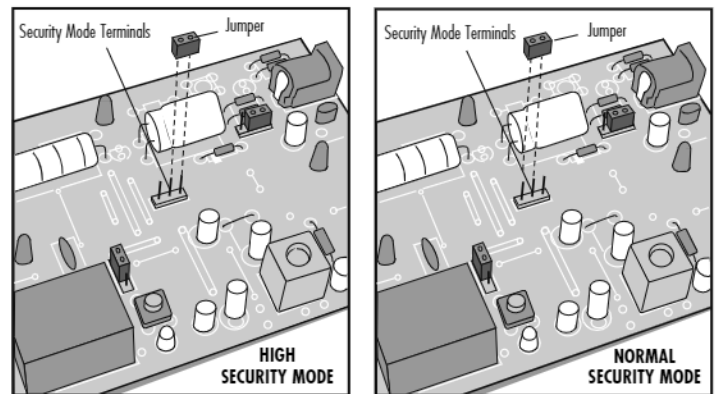

FIGURE 2

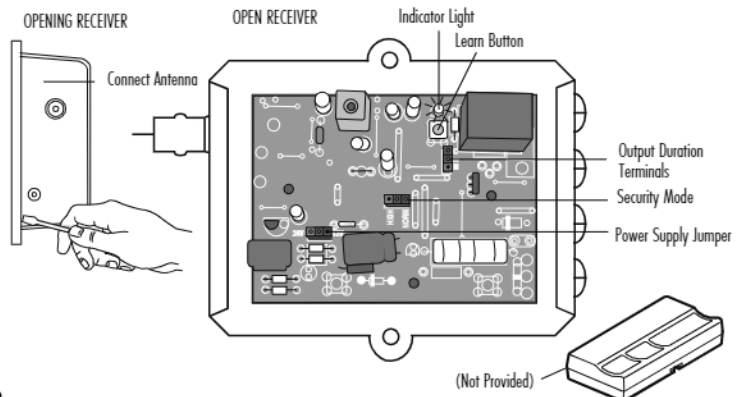
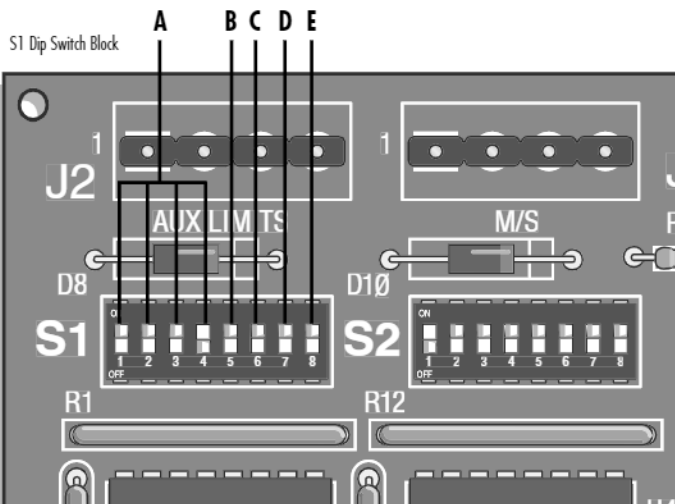

FIGURE 3

**NOTICE:** To comply with FCC and/or Industry Canada (IC) rules, adjustment or modifications of this receiver and/or transmitter are prohibited, except for changing the code setting or replacing the battery. THERE ARE NO OTHER USER SERVICEABLE PARTS. Tested to Comply with FCC Standards FOR HOME OR OFFICE USE. Operation is subject to the following two conditions: (1) this device may not cause harmful interference, and (2) this device must accept any interference received, including interference that may cause undesired operation.

# FEATURES AND FUNCTIONS » S1 DIP SWITCHES

## S1 DIP SWITCHES



### A FAST RUN TIMER (FULL SPEED RUN TIMER) DIP Switch S1-1 to S1-4

When the gate operator activates, it ramps up and slows down for a fixed amount of time, but will run at full speed for variable amounts of time depending upon the settings of the S1-1 to S1-4 DIP switches.

Each DIP switch represents increments of 1/8 second.

When DIP switches S1-1, S1-2 and S1-3 are in the ON position, the Fast Run Timer is set to 2-3/8 seconds by factory default.

When DIP switches S1-1 to S1-4 are set in the OFF position, the full speed run time is 1-1/2 seconds.

The longer the operator runs at full speed, the less ramp up and slow down time. When adjusting, make sure the Fast Run Timer settings DO NOT overrun the slow down time.

### B SINGLE BUTTON FUNCTION (INCLUDING PULSE RADIO RECEIVER OPEN/CLOSE)

#### DIP Switch S1-5

With S1-5 DIP switch in the ON position, the Single Button Function (Command to Open/Command to Close) will activate, with inputs on terminal 4 and Common (COM) on the J5 terminal strip. Any of the terminals 9-12 on the J5 terminal strip can be used for common.

When using this feature with the radio receiver (provided), move the radio wire from terminal 1 to terminal 4 on the J5 terminal strip.

### C CLUTCH OPTION DIP Switch S1-6

With S1-6 DIP switch in the ON position, and using the Clutch Option; when the barrier arm is manually forced UP (OPEN), the barrier arm will automatically CLOSE.

If the Close Loop detects tailgating, the K1 Relay will activate. If an anti-tailgating alarm is wired into terminal strip (J1), an alarm will sound.

**NOTE:** When using the Clutch Option, turn DIP switches S1-6 and S2-7 to the ON position (Auto Close). When this feature is activated the barrier arm will CLOSE by the timer whenever it is forced UP (OPEN).

### D HANDING THE BARRIER ARM DIP Switch S1-7

The J4 Motor Wiring is controlled by DIP switch S1-7. The Handing of the Barrier Arm may be changed from right-hand to left-hand operation by reversing the factory default motor connections.

**NOTE:** Right-hand or left-hand operation is determined by facing the control board with the barrier arm in the CLOSED position. If the barrier arm is to the right, it is set for right-hand gate operation.

1. Disconnect power to the operator.
2. For left-hand operation reverse the motor wires on J4-7 (blue wire) and J4-8 (orange wire) (see below).

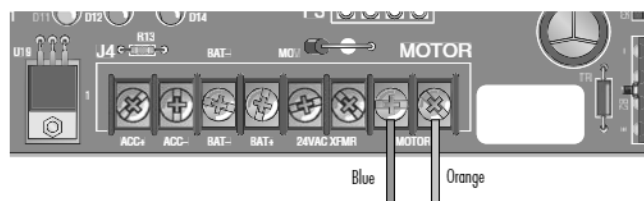

3. Set DIP switch S1-7 to the ON position.
4. Turn the motor pulley until the barrier arm is to the left.
5. Turn the Limit Cam so the Limit Cam is parallel to the arm and just behind the limit sensor.
6. Connect power to the operator.

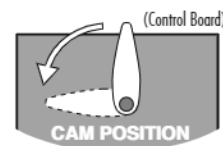

### E K1 RELAY (OPTIONAL) DIP Switch S1-8

Auxiliary devices such as Counters, Alarms, Buzzers, and SAMS (Sequence Access Management System), can be wired into the K1 Relay and terminal strip (J1).

When S1-8 DIP switch is in the OFF position, the K1 Relay will activate throughout the OPEN cycle.

When S1-8 DIP switch is in the ON position, the K1 Relay will be activated briefly until the OPEN LIMIT (OLS) is reached.

# FEATURES AND FUNCTIONS » S2 DIP SWITCHES

## S2 DIP SWITCHES

S2 Dip Switch Block

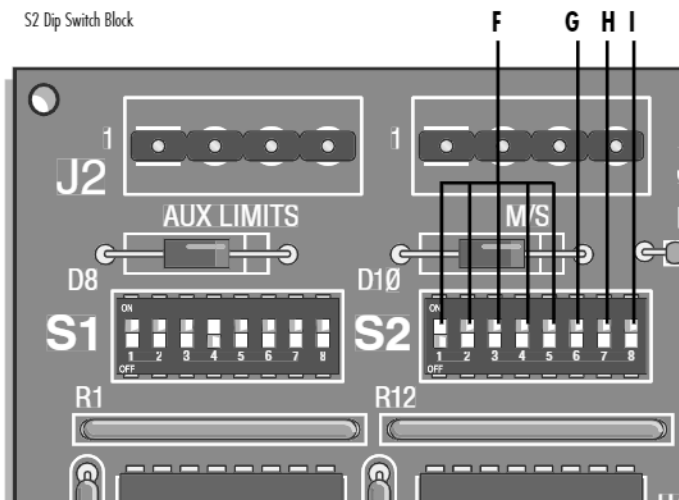

### F TIMER-TO-CLOSE

#### DIP Switch S2-1 to S2-5

The S2-1 to S2-5 DIP switches will set the period of time the gate remains opened after reaching the OPEN position.

Each DIP switch represents the number of seconds the gate will remain OPEN before CLOSING. With the S2-3 DIP switch in the ON (factory default) position, there are 4 seconds to allow a vehicle enough time to move out of the path of the closing barrier arm.

Turning multiple switches ON will combine the amount of time the barrier arm remains OPEN.

The maximum hold OPEN time is 32 seconds.

To de-activate this feature turn S2-7 DIP switch to the OFF position.

### G MULTIPLE VEHICLE MEMORY

#### DIP Switch S2-6

With S2-6 DIP switch in the ON position, the Multiple Vehicle Memory will activate, with inputs on terminal 4 and Common (COM) on the J5 terminal strip. Any of the terminals 9-12 on the J5 terminal strip can be used for common.

**NOTE:** With Multiple Vehicle Memory activated, the barrier arm will remain OPEN until the pre-authorized number of vehicles pass over the Close Loop.

### H AUTO CLOSE

#### DIP Switch S2-7

The S2-7 DIP switch (Auto Close) should be activated in case one or more of the pre-authorized vehicles DO NOT pass through the gate. The barrier arm will close after the set amount of time elapses and the count memory is reset to zero.

### I FAIL SAFE (AUTO OPEN ON AC POWER FAILURE)

#### DIP Switch S2-8

With S2-8 DIP switch in the ON position, the barrier arm will automatically OPEN approximately 15 seconds after a loss of power. Once the power has been restored the operator will resume normal operation after any input.

With S2-8 DIP switch in the OFF position, the barrier arm will resume normal operation until the batteries drop below 50% at which time the barrier arm will OPEN and remain opened until the batteries are fully charged.

# ADJUSTMENTS » INSTANT REVERSE DEVICE (IRD) + INSTALL THE BARRIER ARM

## ⚠️ WARNING

To reduce the risk of **SERIOUS INJURY** or **DEATH**:

- Disconnect power **BEFORE** performing **ANY** adjustments near drive shaft.

### INSTANT REVERSE DEVICE (IRD)

Adjustments to be done by qualified service persons only.

The instant reverse device is an internal circuit that continuously monitors the motor's current for increased draw in order to detect obstructions. If the arm is obstructed while closing the arm will reverse to the open position, time out (using the time delay set at S-2 switches 1-5) and then close. If arm is obstructed while opening, the arm will stop, time out (using the time delay set at S-2 switches 1-5) and then close.

Turning the IRD1 right (clockwise more sensitive), or left (counter clockwise less sensitive) in small increments will allow sensitivity adjustments (IF ARM DOES NOT REVERSE, DO NOT CONTINUE TO FORCE).

- 1 Place an obstruction in the path of the arm. Adjust sensitivity so that consistent reversal occurs when the arm hits the obstruction. If the gate stops while opening then the IRD is TOO sensitive.

**NOTE:** Instant reverse device (IRD) should be tested monthly to ensure proper operation.

### ADJUST THE BARRIER ARM

The arm should be level in the **HORIZONTAL POSITION**. If the arm is not level it can be adjusted by sliding the control board and/or adjusting the limit cam. The control board has two sensors on the back of the control board that sense when the limit cam has reached the open and close limit.

- **If the arm is closing too far:** Loosen the control board screws and slide the control board **UP** to increase the time it takes for the limit cam to travel between each sensor.
- **If the arm is not closing far enough:** Loosen the control board screws and slide the control board **DOWN** to decrease the time it takes for the limit cam to travel between each sensor.
- **If the arm is not stopping at the limits:** Move the limit cam closer to the control board by loosening the set screw on the limit cam.

After any adjustment open and close the arm to test if the arm is level. Ensure the limit cam set screw and control board screws are tight when adjustments are done.

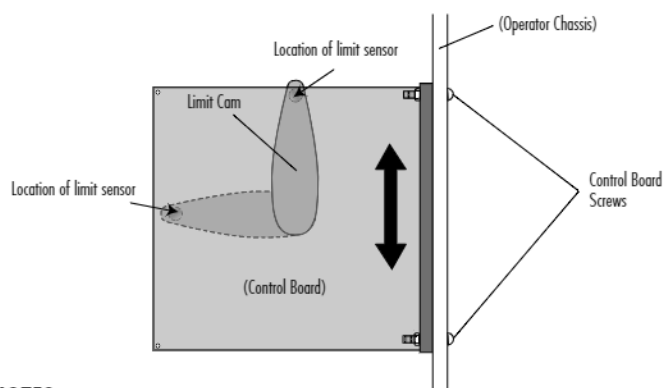
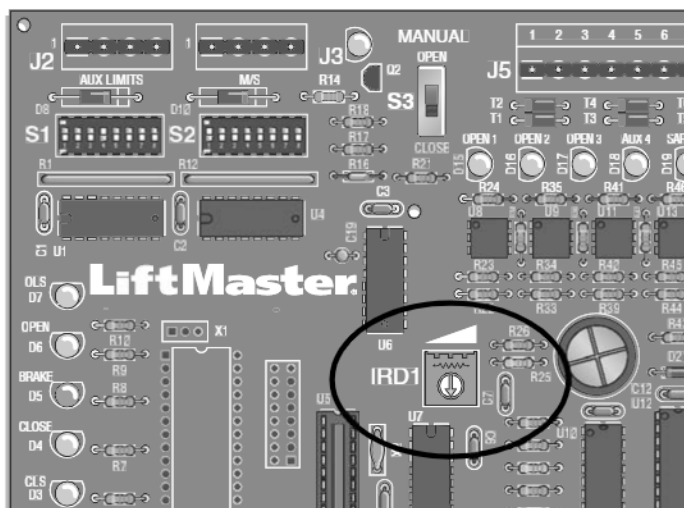

#### NOTES:

- In some cases, additional adjustments may be required after the belt wears in.
- To prevent entrapment, allow for two (2) feet minimum clearance past end of arm when in down position.

# OPERATION AND MAINTENANCE » IMPORTANT SAFETY INSTRUCTIONS

## IMPORTANT SAFETY INSTRUCTIONS

### ⚠️ ⚠️ WARNING

To reduce the risk of **SEVERE INJURY** or **DEATH**:

1. READ AND FOLLOW ALL INSTRUCTIONS.
2. NEVER let children operate or play with gate controls. Keep the remote control away from children.
3. ALWAYS keep people and objects away from the gate. NO ONE SHOULD CROSS THE PATH OF THE MOVING GATE.
4. Test the gate operator monthly. The gate MUST reverse on contact with a rigid object or stop when an object activates the non-contact sensors. After adjusting the force or the limit of travel, retest the gate operator. Failure to adjust and retest the gate operator properly can increase the risk of INJURY or DEATH.
5. Use the emergency release ONLY when the gate is not moving.
6. KEEP GATES PROPERLY MAINTAINED. Read the owner's manual. Have a qualified service person make repairs to gate hardware.
7. The entrance is for vehicles ONLY. Pedestrians MUST use separate entrance.
8. Disconnect ALL power BEFORE performing ANY maintenance.
9. ALL maintenance MUST be performed by a LiftMaster professional.
10. SAVE THESE INSTRUCTIONS.

# OPERATION AND MAINTENANCE » GENERAL SERVICE + SHEAR PIN REPLACEMENT + BATTERY

## **WARNING**

To avoid **SERIOUS PERSONAL INJURY** or **DEATH** from electrocution, disconnect **ALL** electric power **BEFORE** performing **ANY** maintenance.

Check at the intervals listed in the following chart:

ITEM	PROCEDURE	EVERY 3 MONTHS	EVERY 6 MONTHS	EVERY 12 MONTHS	EVERY 24 MONTHS
Fasteners	Check and tighten as required		●	◆	
Bearings and Shafts	Check for wear and lubricate	●		◆	
Battery Maintenance	Replace batteries.			◆	●

◆ Repeat **ALL** procedures.

## GENERAL SERVICE

- If the belt is loose or needs replacement, adjust with 4 bolts that support motor to allow 1/4" play.
- Battery voltage should be 27.5 +0.05, -0 Vdc disconnected (set with R63, shown on the Control Board Layout page).

## SHEAR PIN REPLACEMENT

If gate arm is vandalized and the tapered pin in the output shaft has been sheared, it must be replaced correctly and with the right pin type. Replacement must be done by always punching out the pin (or pieces) from the small end only. If drilling is required, **DO NOT DAMAGE THE SHAFT**, use a drill bit smaller than the small hole size of the pin. (Correct pin (P/N MA013) is a 2" pin with a number 6 taper only.)

**NEVER USE A BOLT AS A TEMPORARY FIX, THIS WILL DAMAGE THE SHAFT AND COLLAR.**

1. Turn the S3 Manual Open switch to OPEN on the control board to rotate gate arm bracket to the up position.
2. Disconnect AC power and disconnect batteries.
3. Remove the gate arm bracket and pieces in collar.
4. Drive out pin pieces with hammer and punch (Solid sharp blows are better than light ones).
5. Reinstall gate arm bracket.
6. Lightly oil the new pin and insert into collar.
7. Fully seat pin in shaft by tapping on large end.
8. Reinstall the barrier arm if required.
9. Connect AC power and batteries.
10. Turn off S3 Manual Open switch to CLOSE to put gate into operation.

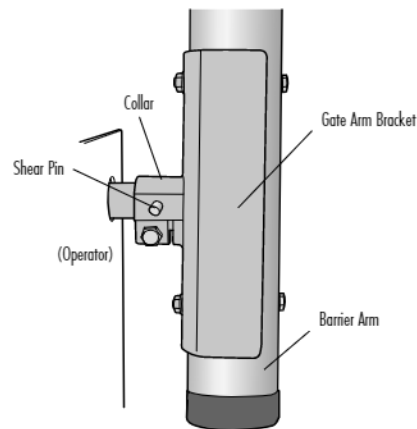

## BATTERY

### BATTERY DISPOSAL

Replaced batteries must be treated as a hazardous waste and disposed of in accordance with State, Local and Federal Regulations. See the battery manufacturer's Material Safety Data Sheets (01-30839 "MSDS Sheets, Battery, Standard").

### BATTERY REPLACEMENT

Service Kits are available for battery replacement. Please contact Technical Support (see back of this document for contact information). Replace the batteries with LiftMaster P/N MBAT batteries. Replace in pairs.

### BATTERY MAINTENANCE / TESTING

The batteries are maintenance free. However, to ensure proper and safe operation, it is recommended that the batteries be replaced every two years. Battery testing is conducted automatically. See the Battery Test Description section for manually initiating the battery test.

### BATTERY HANDLING / STORAGE

Refer to the battery manufacturer's Material Safety Data Sheets (01-30839 "MSDS Sheets, Battery, Standard"). LiftMaster does not recommend storage of batteries in the field. Batteries are intended for immediate use.



# ADDITIONAL FEATURES » SUGGESTED LOOP SENSOR LOCATIONS

## SUGGESTED LOOP SENSOR LOCATIONS

Do not allow control devices to be within 10 feet of gate or operator.

### RECOMMENDATIONS:

- If vehicle detectors are used to open or close the gate, use of the presence contacts are recommended. Using the pulse contacts will **REDUCE** the gate's safe operation.
- If closing timer is to be used, use **ONLY** on a dedicated free exit.
- Close loop must be centered under gate arm.

### FREE EXIT ON VEHICLE APPROACH

Gate will open when sensed by exit loop and then close once the close loop is cleared. If the vehicle pulls up to the exit loop and then backs away, it will close.

Space between loops will be 4 to 10 feet.

Terminal #7 is backaway (free exit).

Terminal #6 is close input.

### ENTRY WITH ACCESS CONTROL DEVICE

Gate will open when activated by an access control device. When vehicle passes and clears close loop, gate will close.

**NOTE:** If a second vehicle tail-gates and is sensed at the close loop, gate will stop its closing motion until loop is cleared again.

Terminal #6 is close input.

Terminals #1, 2, and 3 are open inputs.

### DUAL DIRECTION AS ENTRY OR FREE EXIT

Dual direction is a combination of both of the above configurations to provide the ability for traffic to enter or exit in the same lane.

Space between loops will be 4 to 10 feet.

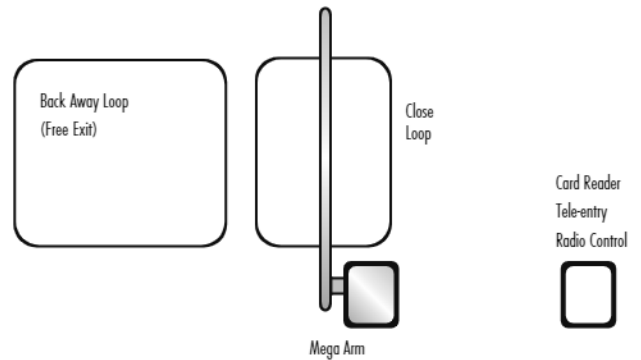
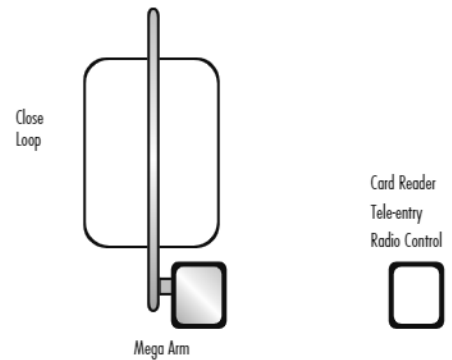
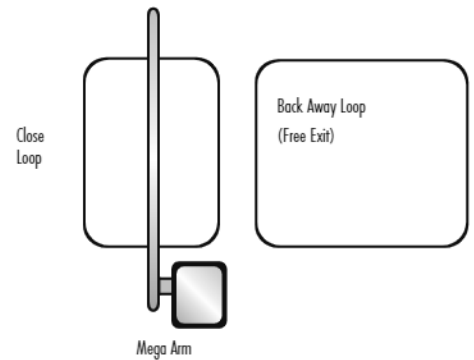



# ADDITIONAL FEATURES » SEQUENCE ACCESS MANAGEMENT SYSTEM (SAMS) WITH "MEMORY"

## SEQUENCE ACCESS MANAGEMENT SYSTEM (SAMS) WITH "MEMORY"

### SAMS WITH OTHER OPERATORS

#### REQUIRES THE K1 RELAY OPTION (Order SAMS KIT)

This feature allows a logical interface between the MEGA ARM barrier gate and a swing, slide, etc. gate operator (or MTC-31). All that is required is 4 wires between the MEGA ARM barrier gate and the other operator. It will be necessary to have one set of dedicated/isolated dry contacts - {C. and N.C.} COMMON and NORMALLY CLOSED be available at the other operator's OPEN LIMIT SWITCH. Most operators will require that this EXTRA limit switch be added to their open limit switch assembly.

#### OPERATION

At one second pulse from access control device to the MEGA ARM will energize its K1 relay sending an open signal to the other operator causing it to open. However, the MEGA ARM's barrier arm will not raise yet. When the other operator reaches its full open limit switch, this will open the COMMON and NORMALLY CLOSED contact on the EXTRA open limit switch. This will allow the original signal from your access control device (that was stored in memory) to now raise the barrier arm. As long as the other operator is in the full open position, any additional open pulse sent will in turn energize the MEGA ARM's K1 relay to send another open signal to the other operator as well as cause the arm to raise again if it has closed via a car crossing the MEGA ARM's close loop.

#### WIRING:

1. Run 2 wires from the other operator's isolated common & normally closed contacts of its open limit switch to the MEGA ARM J5#8 and one of the commons J5, #9-12.
2. Run 2 wires from the MEGA ARM's K1 relay (common & normally open) to the other operator's common and open input. (**WARNING:** Max of 30 VOLTS at .5 amps through relay). J5 #8 was the unused SHADOW LOOP input on the MEGA ARM. **NOTE:** A separate open device (24 hour timer, toggle switch) can be run to the other operator to control it without raising the gate arm. Tampering with the other operator's safety loops, safety edges and reverse sensors WILL NOT cause the arm to raise if one tripped. The arm will only raise if an intended open signal was sent to the MEGA ARM.

#### NOTES:

- For motorized teeth, vertical pivot or overhead operator, leave S1-6, S1-8 OFF (this will keep the K1 relay latched down until the arm reaches the down position. This will keep the other gate operator locked open or teeth locked down until the arm closes completely).
- In this mode, if the arm senses an impact, the K1 relay will stay energized holding open (or teeth down) the other operator until the arm times out and closes.

**NOTE:** Insert a jumper across the JP2 terminal to allow the SAMS feature to work with the multiple vehicle memory count selection, use the K1 relay to open the sequenced gate (S1-5 off, S2-6 on, jumper across JP2). This allows gate to store input counts via J5 #4 but not raise the arm until the sequenced slide or swing gate has fully opened.

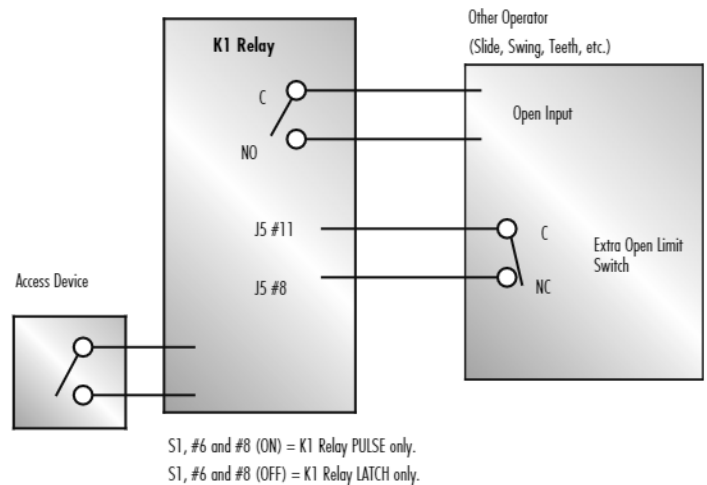

# ADDITIONAL FEATURES » CONTROL BOARD LAYOUT + INPUT LOCATIONS

## CONTROL BOARD LAYOUT

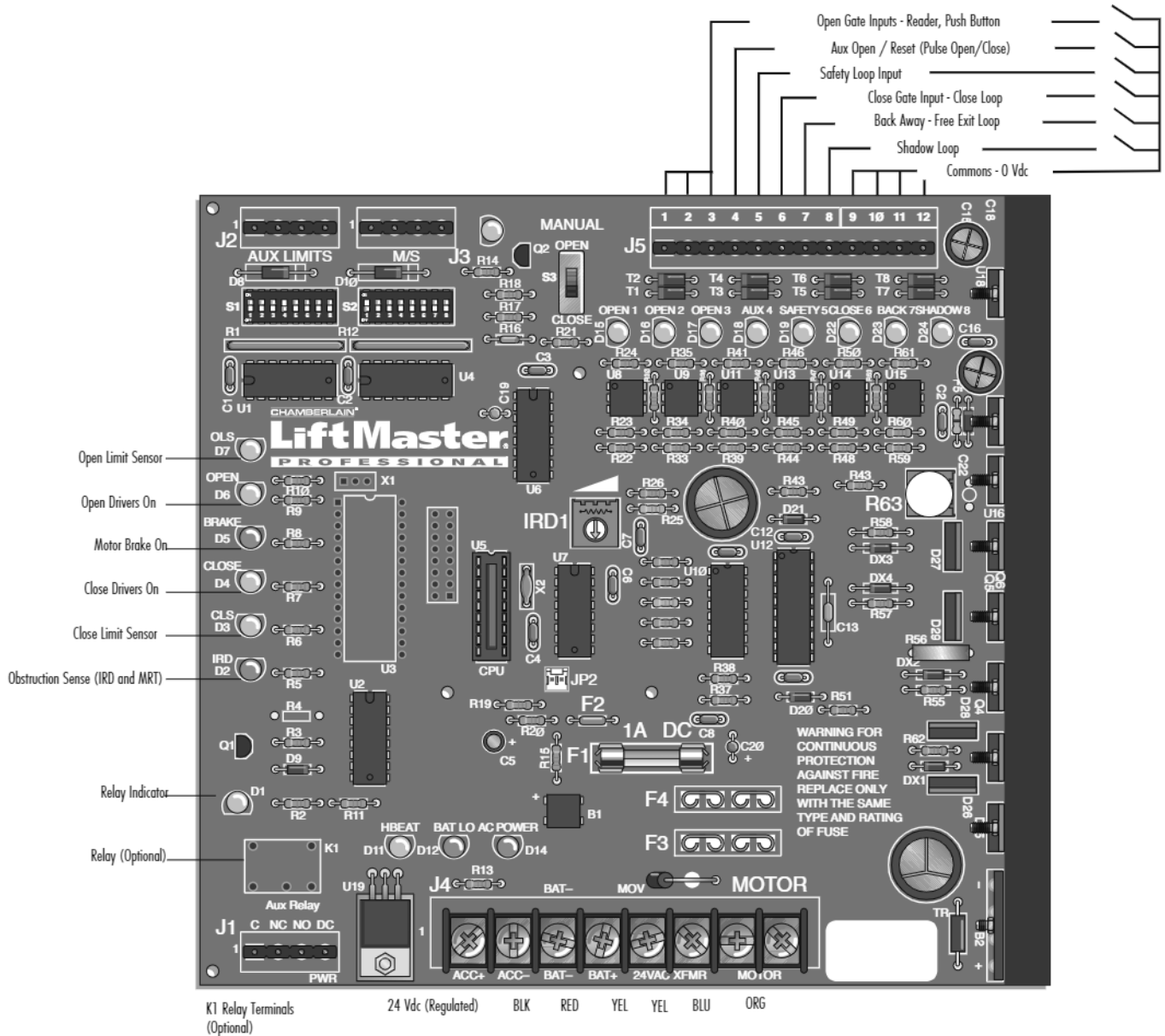

## INPUT LOCATIONS

Accessory power is 24 Vdc regulated rated at 500 ma. [1/2 amp].

**NOTE:** J5 #8 is now the SAMS with memory input (see page 13).

**D11:** Heart beat. Shows that processor and program are running properly.

**D12:** Battery status. See diagnostic procedures.

**D14:** AC power indicator. Shows that AC power is present.

**S3:** Manual open. To allow gate to be opened or closed during service of operator. Keep in the "Close" position for normal operation.

**F3:** 10 amp ATO type fuse for 24 Vac input power. (UL listed fuse only.)

**F4:** 15 amp ATO type fuse for 24 Vdc battery input power. (UL listed fuse only.)

# TROUBLESHOOTING » BATTERY CHECKOUT + GATE NOT OPERATING

**WARNING - DISCONNECT BATTERIES AND AC POWER BEFORE SERVICING ANY MECHANICAL OR MOVING COMPONENTS.**

## BATTERY CHECKOUT

When the batteries become weak the gate will begin to run noticeably slower.

**NOTE:** Batteries should only be checked when you are sure they have had adequate time to fully charge.

1. Turn off the AC power and run gate for 5 to 10 cycles while observing low battery indicator LED D12. If LED 12 comes ON, batteries are too weak to function properly. If LED 12 does not light, then voltage should be checked as they still maybe near failure. Correct voltage is approximately 24.5 Vdc.

**NOTE:** If LED D12 does light, gate will open to conserve batteries in this test or in a real power loss, even if mode switch 8 on S2 is off.

Return of AC power will clear low battery indicator. Correct charge voltage is 27.5 Vdc with batteries not connected (set with R63, shown on the Control Board Layout page).

## GATE NOT OPERATING

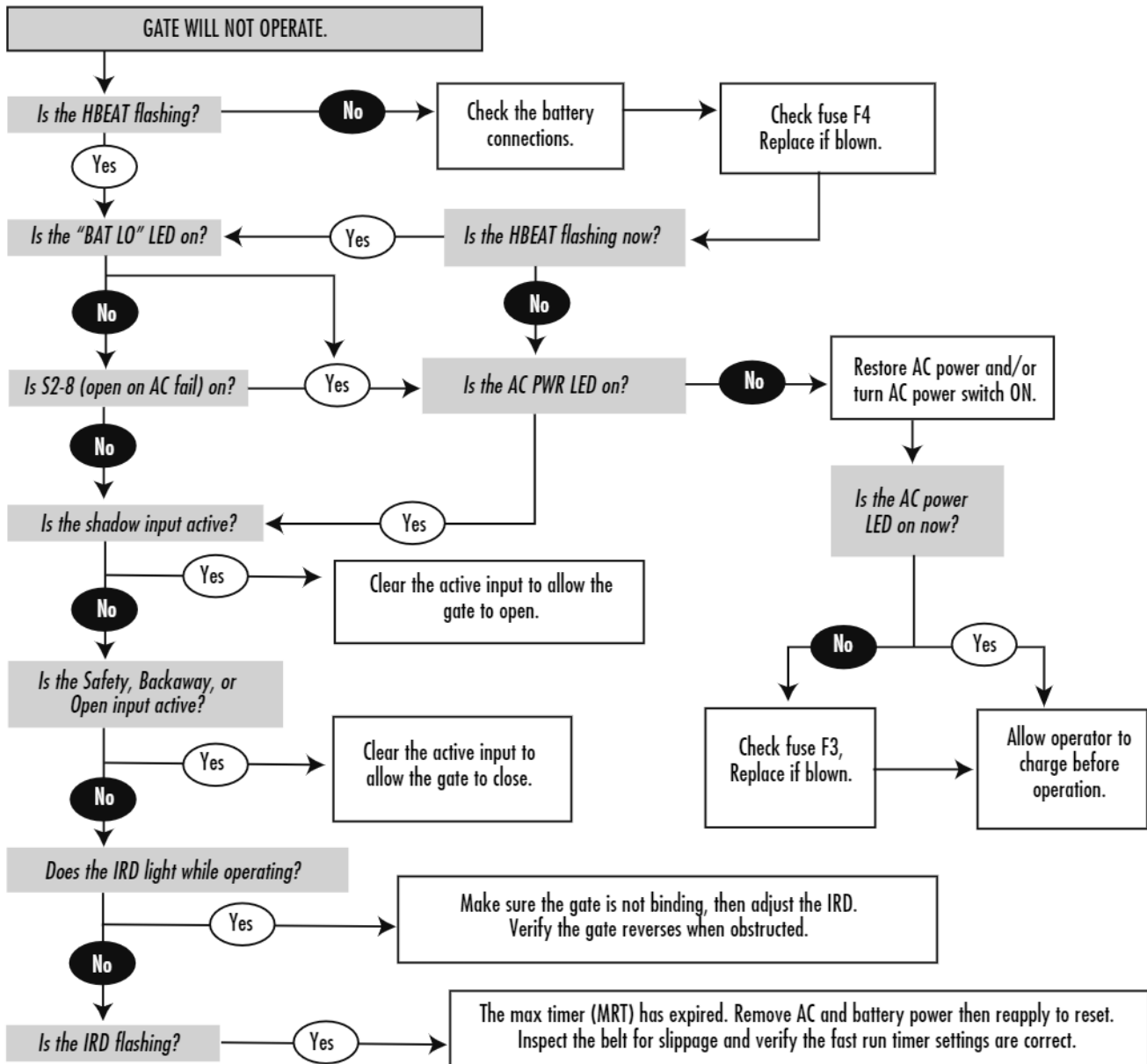

# REPAIR PARTS » PART NUMBERS AND DESCRIPTIONS + PARTS SHIPPED + MEGA ARM TOWER UNIQUE PARTS LIST + MEGA ARM OPTIONS PARTS LIST

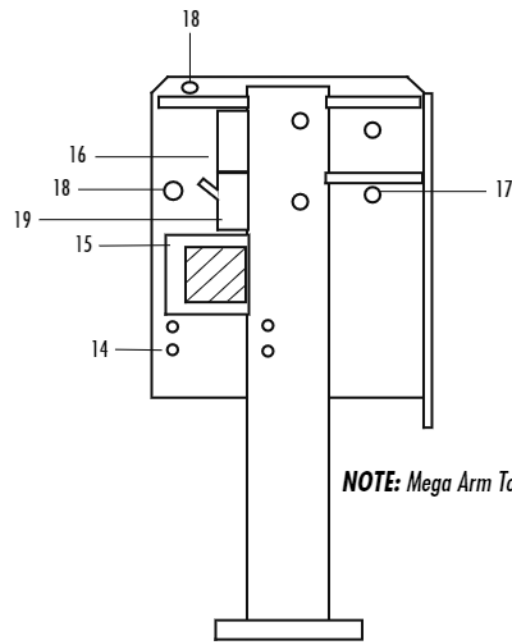
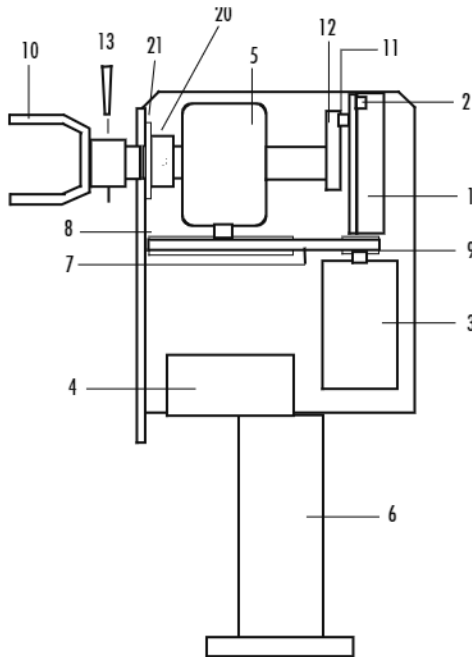

**NOTE:** Mega Arm Tower not shown

## PART NUMBERS AND DESCRIPTIONS

ITEM	PART NUMBER	DESCRIPTION	ITEM	PART NUMBER	DESCRIPTION
1	MA001	Controller	14	MA014	Bolt and Nut (4) Motor
2	MA002	Removable Connector	15	MA015	Transformer
3	MA003	DC Motor - 24 Vdc	16	MA016	120 Vac Duplex Outlet (120 Vac Only)
4	MBAT	12 Vdc 7AH Battery 2 required	17	MA017	Bolt and Nut (4) Reducer
5	MA005	Gear Reducer 60:1	19	MA019	On/Off Switch
6	MA006	Aluminum Chassis	*	MA020	Operator Cover for Mega Arm (Not Tower)
7	MA007	Drive Belt	*	MA021	Nylon Arm Nuts (2)
8	MA008	Reducer Pulley	*	MA022	Arm Bolts (2)
9	MA009	Motor Pulley	*	MA023	Gate Arm - 12'
10	MA010	Gate Arm Bracket	*	73A3	Filter Module
11	MA011	Magnet	*	74-31243	Surge Suppressor
12	MA012	Cam Arm	20	MA036	Collar
13	MA013	Shear Pin	21	MA037	Nylon Washer

(\* ) parts not shown

## PARTS SHIPPED

ITEM	QTY
MEGA ARM Operator Controller	1
Operator Cover	1
Installation and Service Manual	1
Arm Bolts with Washers	2
Nylon Nuts	10
7AH Batteries	2

## MEGA ARM TOWER UNIQUE PARTS LIST

ITEM	PART NUMBER	DESCRIPTION
*	MA020T	Operator Cover for Mega Arm Tower
*	MA020D	Operator Door for Mega Arm Tower

## MEGA ARM OPTIONS PARTS LIST

ITEM	PART NUMBER	DESCRIPTION
*	71-TRAP	Trap option
*	71-SPRINT	Sprint option
*	71-TRAPSP	Sprint Trap option

# ACCESSORIES

## REMOTE CONTROLS

Chamberlain offers a variety of LiftMaster Security+® and Passport™ remote controls to satisfy your application needs. Single-button to 4-button, visor or key chain. Additionally, Passport™ remote controls are ideal for integration with Telephone Entry and Access Control Systems. Contact your authorized LiftMaster dealer for details.

### SECURITY+® SINGLE BUTTON REMOTE CONTROL

Includes visor clip. Model 371LM

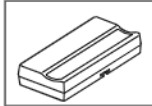

### SECURITY+® 3-BUTTON REMOTE CONTROL

Includes visor clip. Model 373LM

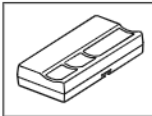

### SECURITY+® 4-BUTTON REMOTE CONTROL

Includes visor clip. Model 374LM

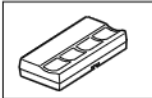

### PASSPORT™ 1-BUTTON REMOTE CONTROL

Includes visor clip. Model CPT13.



### PASSPORT™ 3-BUTTON REMOTE CONTROL

Includes visor clip. Model CPT33

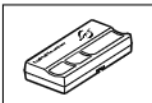

### PASSPORT™ 4-BUTTON REMOTE CONTROL

Includes visor clip. Model CPT43



## MISCELLANEOUS

### 24 VDC LOOP DETECTOR

Model A24

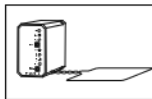

### WIRING HARNESS

For the A24. Model A57

### HEATER KIT

500 watt with thermostat (MAT and MATS only). Model UN201

### SLIP CLUTCH OPTION

For Mega Arm Gear Box. Model MA005C

### K1 RELAY OUTPUT OPTION

Model MA200

### ALUMINUM ARM

White, 12' x 3" diameter with warning labels. Model MA023

### ALUMINUM ARM:

12' x 3" diameter with yellow/black stripes. Model MA024

### ALUMINUM ARM

12' x 3" diameter with reflective yellow/black stripes. Model MA024R (Highly Recommended)

### SAMSKIT

Includes required relay and limits.

### NYLON ARM NUTS

(Pkg. of 50). Model MA021

### NYLON ARM NUTS

(Pkg. of 50), thin. Model MA021A

### ADAPTER COLLARS

For padded arm option (2 included). Model MA031

### ROUND PADDED ARM

12' x 4" diameter, yellow (requires MA031). Model MA025

### REPLACEMENT PAD:

12' x 4" diameter, yellow. Model MA026

### REPLACEMENT ARM TUBE

12' x 2" diameter. Model MA027

### ROUND PADDED ARM

14' x 4" diameter, yellow (requires MA031). Model MA028

### REPLACEMENT PAD

14' x 4", yellow. Model MA029

### REPLACEMENT ARM TUBE

14' x 4". Model MA030

### COUNTER WEIGHT

Required for all 15' arms. Model MA117

### ALUMINUM GATE ARM

White, 15' x 3" (requires MA117). Model MA115

### ALUMINUM GATE ARM

15' x 3" with yellow/black stripes (requires MA117). Model MA116

### ALUMINUM GATE ARM

15' x 3" with reflective yellow/black stripes (requires MA117). Model MA116R

### ARTICULATING PVC (FOLDING) ARM

9' with hardware kit. Model MA034 (Highly Recommended)

### HARDWARE KIT

(Only for MA034). Model MA033

### PVC ARM: 9'

(Only for MA034). Model MA035

### ARTICULATION ALUMINUM (FOLDING) ARM:

10' without hardware kit, with yellow/black stripes. Model MA024-10

### MA230VKIT

Includes surge suppressor, wire jumper, duplex box covers and detailed instructions.

## SPRINT OPERATORS ONLY

### SPRINT GATE ARM

8' Padded Safety Arm, yellow. Model SP8

### REPLACEMENT ARM TUBE

Model SP8 TUBE

### REPLACEMENT PAD

Yellow. Model SP8 PAD

# WARRANTY POLICY

(YOU MUST READ, UNDERSTAND AND AGREE WITH ALL ITEMS IN THE LIMITED WARRANTY)

LiftMaster warrants the **MEGA ARM-UL** to be free of defects in workmanship and materials for a period of 2 years for electronics and mechanical components and includes a 10 year corrosion perforation warranty on the cover and chassis. Warranty will begin from the date of purchase.

LiftMaster reserves the right of final determination as to the existence and causes of any defect or failure. Any part or parts found to be defective and are returned to LiftMaster within the warranty period, shall at our option be repaired or replaced free of charge F.O.B. the factory. Freight is not included at any time on gate arms and chassis. ONLY UPS ground freight is included during the first year of warranty.

The warranty will not apply the following circumstances which are considered beyond our control.

Mis-use, vandalism, accident, neglect, unauthorized repairs or modifications, acts of God (lightning, floods, insect damage, etc.), power surges, units subjected to corrosive environments, incorrect installation or application, the batteries or incorrect battery installation, operation without or failure to use correct battery type, damage to arm bracket and/or gear reducer due to use of incorrect arm.

The warranty set forth above is entirely exclusive and no other warranty whether written or oral, is expressed or implied. LiftMaster specifically disclaims any and all implied warranties, merchantability or fitness for a particular purpose. It is the purchasers sole and exclusive responsibility to determine whether or not the equipment will be suitable for a particular purpose. In no event shall LiftMaster, inc. be held liable for direct, indirect, incidental, special, consequential damages or loss of profits whether based on contract, tort, or any other legal theory during the course of the warranty or at any time there after. The installer and/or end user agree to assume all responsibility for all liability in use of this product, releasing LiftMaster of all liability.

**WARNING! MEGA ARM NOT FOR USE WITH BICYCLES OR PEDESTRIANS. YOU MUST PROVIDE APPROPRIATE SIGNAGE BEFORE ACTIVATING THE UNIT. NEVER ALLOW CHILDREN TO PLAY NEAR OR OPERATE AUTOMATIC GATES.**

IN ORDER TO INSTALL AND USE THE MEGA ARM, YOU MUST UNDERSTAND AND BE IN FULL UNCONDITIONAL AGREEMENT WITH ALL STIPULATIONS OUTLINED ABOVE. IF YOU ARE NOT IN FULL AGREEMENT, DO NOT PUT UNIT INTO OPERATION. IF OPERATOR IS PUT INTO OPERATION THIS WILL BE CONFIRMATION THAT YOU ARE IN FULL UNCONDITIONAL AGREEMENT WITH ALL OF THE ABOVE STIPULATIONS.

**Materials, components, features and specifications are subject to change without notice.**

## HOW TO ORDER REPAIR PARTS

OUR LARGE SERVICE ORGANIZATION  
SPANS AMERICA

INSTALLATION AND SERVICE INFORMATION  
SIMPLY DIAL OUR TOLL FREE NUMBER:

**1-800-528-2806**

[www.liftmaster.com](http://www.liftmaster.com)

WHEN ORDERING REPAIR PARTS, ALWAYS GIVE THE FOLLOWING INFORMATION:

- PART NUMBER
- PART NAME
- MODEL NUMBER

ADDRESS ORDERS TO:  
THE CHAMBERLAIN GROUP, INC.  
Technical Support Group  
6050 S. Country Club Road  
Tucson, Arizona 85706