

LiftMaster®

LiftMaster
300 Windsor Drive
Oak Brook, IL 60523
LiftMaster.com

OWNER'S MANUAL **MODELS**

LM21AFCB LM21AFCBVB

ADVANCE FIRE CONTROL RELEASE DEVICE

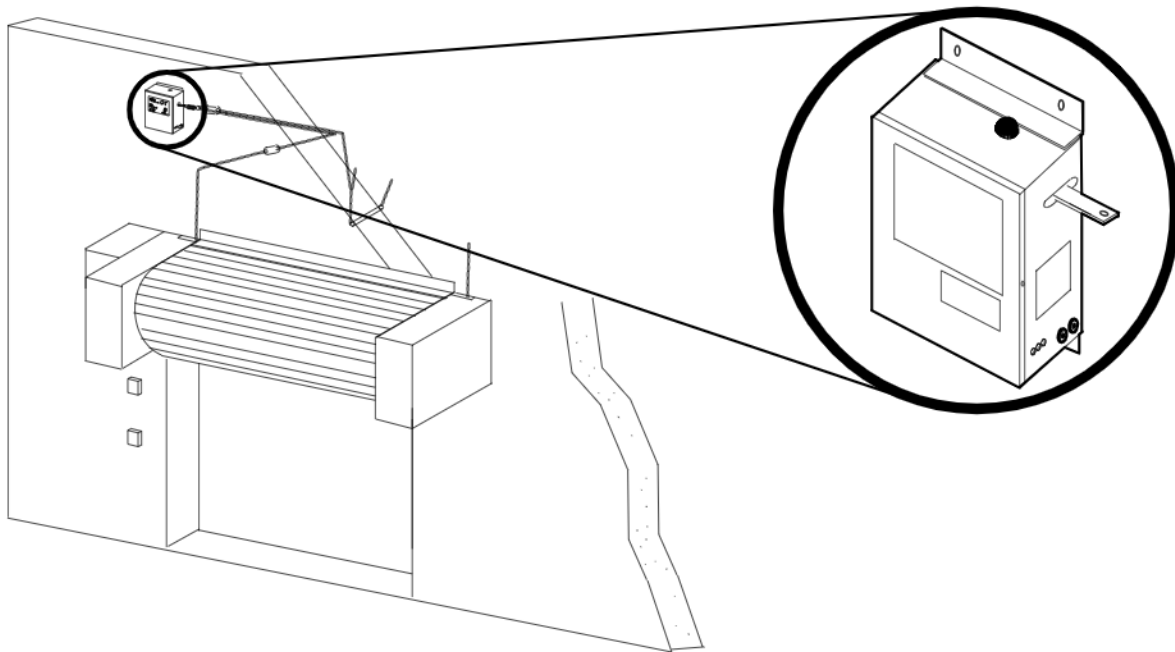

TABLE OF CONTENTS

INTRODUCTION

General Description	2
Agency Requirements	3
Specifications	3
Preparation	3

INSTALLATION

Important Installation Warnings	4
Mount the Release Device	4

WIRING

Power Wiring Connections	5
Connections from Device to the Operator	6
Connections of Initiating Devices and Accessories	7
Optional Connections	8

ADJUSTMENTS

DIP Switch Configuration Setting	9
Selectable Delay Settings (Switches 3 & 4)	9

TESTING

Test Release Device and Door Operator	10-11
Test Release Device With Battery Backup Without AC Power.	12

TROUBLESHOOTING

Diagnostic LEDs	13
---------------------------	----

MAINTENANCE

Maintenance	14
Enclosure Mounted LEDs Status Indicators	14

ACCESSORIES AND REPAIR PARTS 15

APPENDIX 16

WARNING

Mechanical

WARNING

Electrical

CAUTION

When you see these Safety Symbols and Signal Words on the following pages, they will alert you to the possibility of *serious injury* or *death* if you do not comply with the warnings that accompany them. The hazard may come from something mechanical or from electric shock. Read the warnings carefully. When you see this Signal Word on the following pages, it will alert you to the possibility of damage to your door and/or the door operator if you do not comply with the cautionary statements that accompany it. Read them carefully.

IMPORTANT NOTES:

- *BEFORE attempting to install, operate or maintain the release device, you must read and fully understand this manual and follow all safety instructions.*
- *DO NOT attempt repair or service of your release device unless you are an Authorized Service Technician.*



WARNING: This product can expose you to chemicals including lead, which are known to the State of California to cause cancer or birth defects or other reproductive harm. For more information go to www.P65Warnings.ca.gov

INTRODUCTION

GENERAL DESCRIPTION

The LiftMaster® Fire Control LM21AFGB and LM21AFGBVB Release Device is UL/ULC listed normally energized fail-safe device incorporating state-of-the-art electronic control circuitry. This release device is designed to be used with manual doors or motorized doors incorporating a reversing electric safety edge to create an automated door closing system.

The high performance control panel responds to emergency conditions generated from an automatic initiating device. Upon activation, the device will then automatically close a motorized door or mechanically release a door in the absence of motorized operation. If the alarm is still present and power is available to the operator, a motorized door can be opened by depressing the open switch of the operator, after which the door will close again. If the door meets an obstruction while in alarm, the door will reverse and make three attempts to close, after which the motor will be shut off and the door will rest on the obstruction. The release device may also be optionally set to fully open the door and subsequently mechanically release the fire door onto the obstruction.

The device provides 3 count obstruction cycling. A safety timer within the device will turn the motor off and perform a mechanical release if the lower limit is not detected within a predetermined time period. Verify factory-installed options to desired features during initial testing.

Features include a selectable 10, 20, 30 or 60-second time delay on alarm, remote test, motor voltage sensing, Form C relay output, lower limit detection, safety timer, battery support for release device logic, smoke detectors, standard annunciators and trouble diagnostic capabilities (does not support operator). Operating voltage is 120Vac.

As with all releasing device systems, maximum fire protection is provided when installed in accordance with factory specifications and used with fusible link systems.

INTRODUCTION

AGENCY REQUIREMENTS

Installation and testing to factory specifications shall be performed by factory authorized personnel for proper operation in accordance with the latest National Fire Protection Association (NFPA), Underwriters Laboratories (UL), National Electrical Code (NEC), local, state, county, district and/or other applicable building and fire standards, guidelines, regulations and codes including, but not limited to, all appendices and amendments and the requirements of the local authority having jurisdiction (AHJ).

⚠ WARNING

To prevent possible SERIOUS INJURY or DEATH:

- DO NOT install this device on a motorized door without an electric safety edge.
- DO NOT use this device without fusible links installed.
- Test every 90 days to assure proper operation of release device.

SPECIFICATIONS

ELECTRICAL SPECIFICATIONS

VOLTAGE RATING:	120Vac, 60Hz	FUSES:	2A @ 250V, 2AG Slo-Blo Type
STANDBY CURRENT:	.20A	MOTOR CONTROL SENSE:	Input Voltage 24Vac/dc Typical +15% / -10%; Input Current not to exceed .004A
ALARM CURRENT:	.6A	AUXILIARY POWER:	24Vdc @ .75A Maximum
BATTERY RATING:	12V 4.5AH or 5.0AH Sealed Lead Acid Batteries (2), Maximum charge current .150Amps	COMMON ALARM RELAY:	.5A 125Vac 60Hz
BATTERY STANDBY TIME:	Fire Sentinel AFCB, 48 hours Fire Sentinel AFCBVB, 36 hours	(MAX. CONTACT RATING)	1A 24Vdc Resistive
INITIATING DEVICE:	Maximum line impedance 20 ohm; Maximum current not to exceed .010A.; Maximum voltage 24Vdc		

MECHANICAL SPECIFICATIONS

LOAD RATING:	Support and Release 40 lbs. Max.	WEIGHT:	Approximately 18 lbs.
PHYSICAL DIMENSIONS:	10" x 10" x 5" (h x w x d)	(INCLUDING BATTERIES)	

PREPARATION

It is imperative that the wall or mounting surface provide adequate support for the release device.

Refer to the door manufacturer's recommendations for use of this product with specific door being utilized. Use only hardware approved or recognized by the appropriate testing and listing agencies in conjunction with the installation of this product.

Additional items may be required to complete the installation:

- Concrete anchors or fasteners
- Sash chain or 1/16" cable
- Eyebolts-hook
- Fusible links
- Turnbuckles
- Smoke detectors (up to 4 may be installed with this device)

Refer to NFPA 72 and NFPA 80 for instructions concerning proper placement and detection coverage. End-of-line devices shall be installed for supervision of electrical power to 4-wire smoke detector. When using 4-wire smoke detectors with this device, electrical supervision must be provided by means of a UL/ULC listed end-of-line relay.

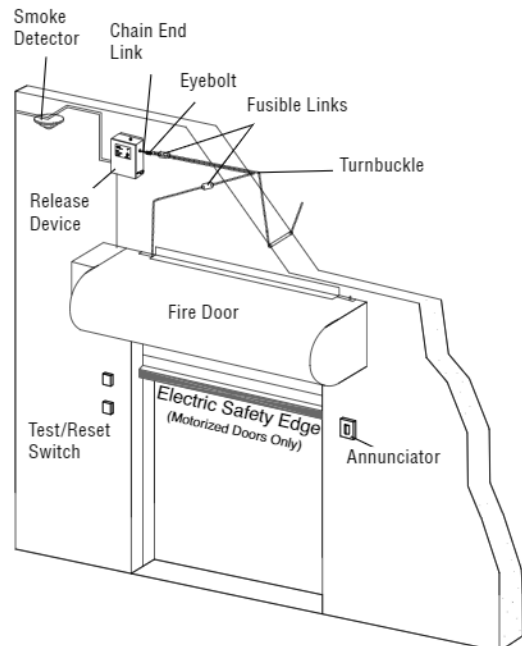

INSTALLATION

IMPORTANT INSTALLATION INSTRUCTIONS

WARNING

To reduce the risk of SEVERE INJURY or DEATH:

1. READ AND FOLLOW ALL INSTALLATION WARNINGS AND INSTRUCTIONS.
2. NEVER connect release device to power source until instructed to do so.
3. DO NOT install this device on a motorized door without an electric safety edge.
4. DO NOT use this device without fusible links installed.
5. Concrete anchors MUST be used if mounting release device into masonry.
6. DO NOT exceed maximum pull rating of 40 lbs. on releasing device.

Classification:

Releasing device as defined by Underwriters Laboratories.

Installation Requirements:

Intended for "Indoor Dry" locations; all wiring must be performed in accordance with the most current version of NFPA 72 - National Fire Alarm Code and the National Electric Code.

MOUNT THE RELEASE DEVICE

Installation procedures vary according to door types. Refer to door manufacturer's recommendation that applies to your door.

1. Mount the release device on a vertical surface with chain end link exiting side of enclosure.
2. Secure the release device enclosure with fasteners (#10 is the minimum size recommended). If installing in masonry, use concrete anchors (not provided).
3. Install hardware (sash chain or 1/16" cable, eyebolts-hook, fusible links, turnbuckles—not provided) according to door manufacturer's recommendations. **NOTE: The end link direction of pull must be perpendicular to the side of the release device enclosure. Install an eyebolt a minimum distance of 12" from the release device to adequately redirect sash chain pull.**
4. Install end link by pressing mechanical reset to allow insertion of end link. Push end link completely in and release mechanical reset to latch end link.
5. Remove sash chain or cable slack by adjusting turnbuckle.

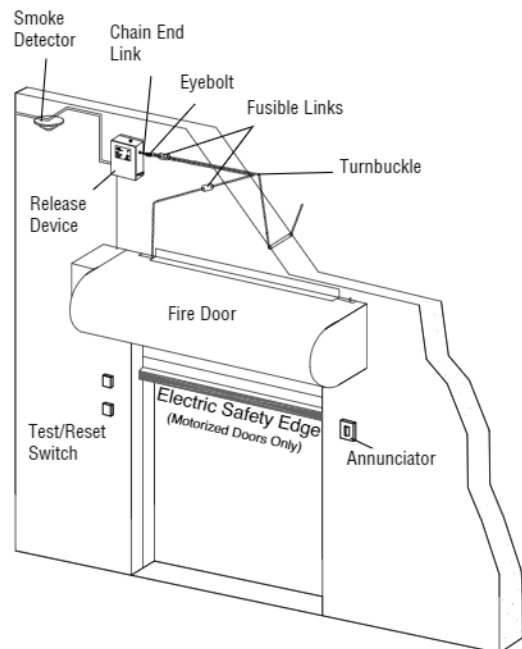
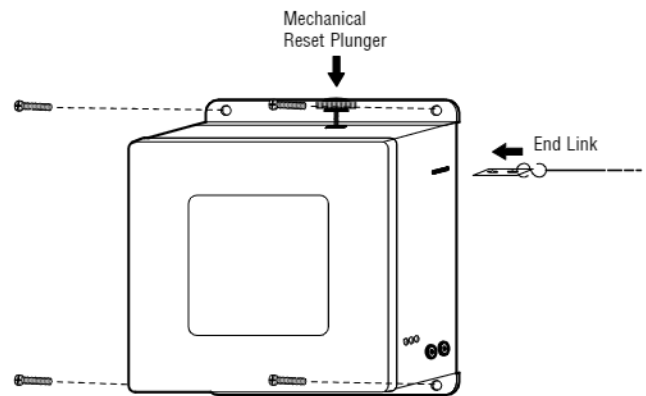

WIRING

⚠️ WARNING

To reduce the risk of SEVERE INJURY or DEATH:

- ALL electrical connections MUST be made by a qualified individual.
- Disconnect power at the fuse box BEFORE proceeding. Release device MUST be properly grounded and connected in accordance with local electrical codes.
- Installation of ALL wiring and connections, including Class 1 and Class 2 circuits, shall be performed in accordance with, but not limited to, the latest NFPA, UL and N.E.C. standards and codes. In addition, ALL installations subject to Canadian standards shall be performed in accordance with the Canadian Electrical Code, Part I, with respect to wiring material type, wiring gauge related to power capacity requirements and circuit length and wiring methods.
- ALL power wiring should be on a dedicated circuit and well protected. The location of the power disconnect should be visible and clearly labeled.
- ALL power and control wiring MUST be run in separate conduit.
- A reversing edge MUST be installed on ALL motorized doors BEFORE proceeding with the installation.

POWER WIRING CONNECTIONS

This device is designed to be used on motorized doors incorporating a reversing feature safety edge. Verify wiring configuration with that recommended by door manufacturer for use of this product with specific door and accessories being utilized.

1. Confirm power source for adequate voltage of 108 to 132Vac.
2. Disconnect power at fuse box to the release device and door operator before continuing.
3. Connect 120Vac (single phase) power source inputs to terminals L1 (line) and L2 (neutral) of the power strip. The third position is used for earth ground. **NOTE:** Do not apply incoming power or connect battery at this point.

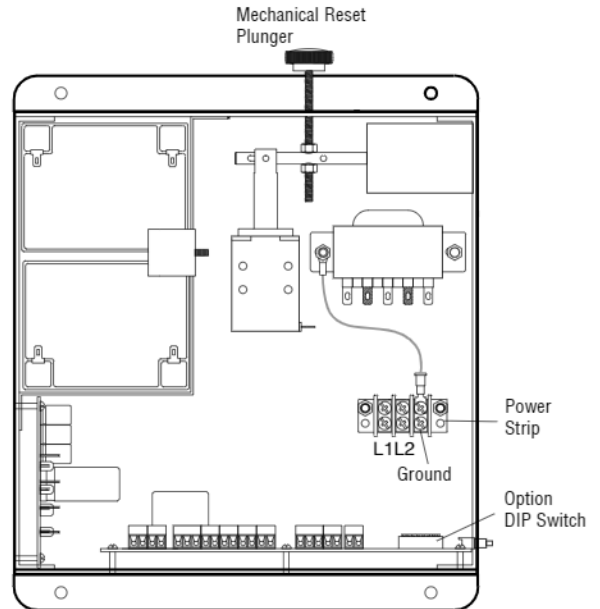

WIRE ROUTING

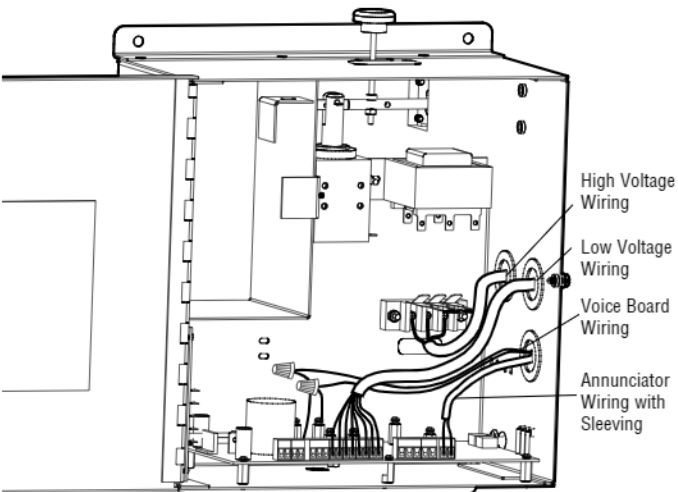

PARTS KIT

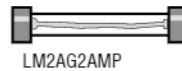

Refer to Wiring section for proper application of these parts.

WIRING

CONNECTIONS FROM DEVICE TO THE OPERATOR

NOTE: For low voltage wiring #18 AWG is recommended.

OPERATOR CONNECTIONS

1. Connect terminals 11 and 12 from the release device to the transformer secondary in the door operator. The required voltage should be 24-30Vac.

NOTE: This connection must be made in order to avoid a mechanical release in alarm conditions when the door is not closed (Figure 2).

2. Connect release device to auxiliary limit switches on the operator. These are required and must be provided by the door operator manufacturer.

Auxiliary Closed Limit Switch (Figure 1):

Connect a wire from the common and N/O of the auxiliary limit switch to terminals 13 and 14 on the release device. This input will not allow a mechanical release if the auxiliary close limit is activated. This circuit also turns off annunciators when the auxiliary close limit is activated.

FIGURE 2

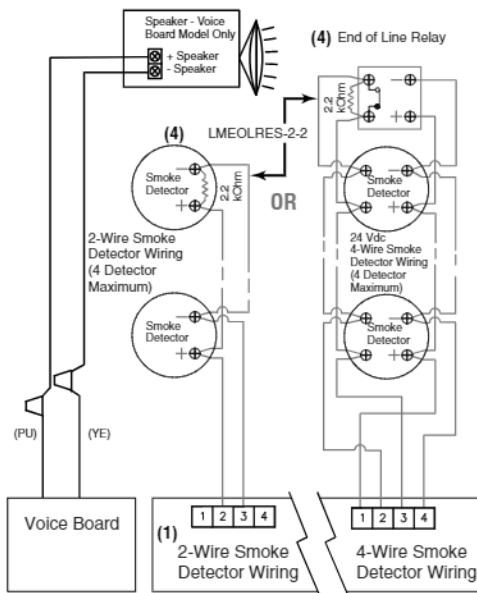

CAUTION

To prevent DAMAGE to the circuit board, auxiliary limit switches MUST be provided as dry contacts and may not be used in conjunction with the simultaneous switching of a motor control or ANY other voltage through the same contacts. Connections of this type will result in immediate damage to the release device.

Auxiliary Open Limit Switch (Figure 1):

Connect a wire from the common and N/O of the auxiliary limit switch to terminals 14 and 15 on the release device. A connection to an auxiliary up limit switch is required for 3-cycle obstruction count feature. Adjust the auxiliary open limit to activate just before the operators open limit is activated.

3. Connect wires from terminals 7, 8, 9, and 10 to the door operator terminals that are used for 3-button station (for use with N/O 'Close' switch, N/O 'Open' switch and N/C 'Stop' switch). The close relay output latches to initiate a door closure through the operator after the factory set delay.

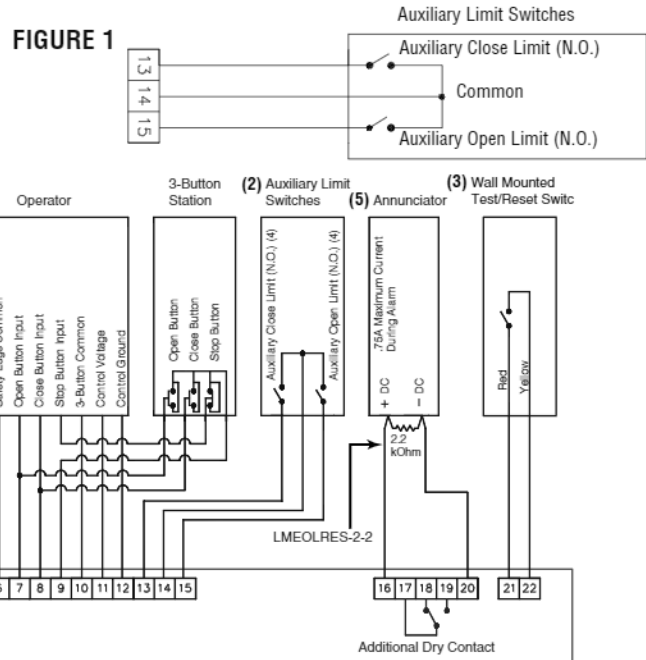

BATTERY CONNECTION / MAINTENANCE

Use two (2) 12V 4.5AH or 5.0AH sealed lead acid batteries in series.
Maximum charge current 1A.
Replace batteries every 2 years.

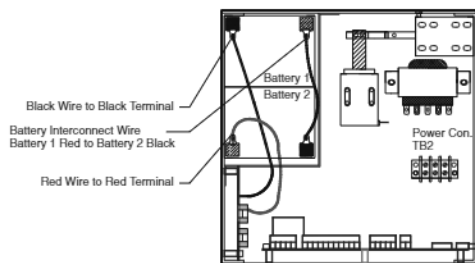

POWER CONNECTION

Replace batteries every 2 years.

Field Wiring shall consist of 22-18 AWG wiring. Use only 250 VAC, 2 Amp, 3 AG Slo-Blo fuses.

1. Supervised, power limited circuit, 20 Ohm maximum line impedance.
2. Unsupervised circuit, 20 Ohm maximum line impedance.
3. Unsupervised, power limited circuit, 20 Ohm maximum line impedance.
4. Maximum of 4 Class B Style A detectors. LMEOLRES-2-2 required for supervision.
5. Maximum of 2 Class B Style W notification appliances. 0.75 Amp at 24 VDC maximum. Supervised, non-power limited circuit. 20 Ohm maximum line impedance. Place 2.2 kOhm resistor between 16 & 20 if unused.

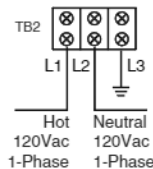

CONNECTIONS OF INITIATING DEVICES AND ACCESSORIES

A maximum of 4 smoke detectors may be installed with this device. Refer to NFPA 72 and NFPA 80 for instructions concerning proper placement and detection coverage. End-of-line devices must be installed for supervision of electrical power to 4-wire smoke detector. When using 4-wire smoke detectors with this device, electrical supervision must be provided by means of a UL/ULC listed end-of-line relay.

NOTE: For low voltage wiring #18 AWG is recommended.

Normally Open "2-Wire," Class B Style A 12Vdc Initiating Devices

1. Connect wiring from N/O initiating device loop to terminals 2 and 3.
2. Place the supervisory resistor (LMEOLRES-2-2) across the terminals of the last initiating device. Observe proper polarity, 2 (+), 3 (-) (Figure 3).

OR

Normally open "4-Wire," Class B Style A Initiating Devices

1. Connect wiring from N/O 4-Wire initiating device loop to terminals 2 and 3. (Do not share alarm loop with other alarm circuits.)
2. Place the supervisory resistor (LMEOLRES-2-2) as illustrated in figure 4 or 5. (Do not share alarm loop with other alarm circuits.)
3. Auxiliary power (+24Vdc) for smoke detectors may be obtained from terminals 1 (+) and 4 (-) for +24Vdc. There is a 4 detector maximum, and an end-of-line relay device must be used (Figures 4 & 5).

NOTE: End-of-line devices must be installed adjacent and after the last initiating device. Initiating device loops are supervised and cannot be direct series or paralleled between multiple release devices or shared with other alarm equipment. For proper wiring configurations from multiple smoke detectors or signaling for simultaneous closure on multiple doors, call technical support, 1-800-929-2553. Incorrect wiring between devices may cause damage to the release control circuit and void warranty.

4. In lieu of smoke detectors, the release device may be put into alarm by the fire alarm control panel. Most commonly, a relay module is used as an interface between the fire alarm control panel and the release device. The relay module must provide Form C dry contacts for connection to the appropriate terminals on the release device (Figure 6).

NOTE: When choosing a relay module to activate the release device in an alarm condition, always select one that provides Form C dry contact relays. Do not use any relay module providing or passing any (control) voltage through the contacts into the release device. The passage of voltage through such a relay module into the release device will cause problems with the operation of the device and may damage the device's terminals and/or circuit board.

⚠ WARNING

To prevent possible **SERIOUS INJURY** or **DEATH**:

- End-of-line devices **MUST** be installed for supervision of electrical power to 4-wire smoke detector.
- **DO NOT** install this device on a motorized door without an electric safety edge.

FIGURE 3

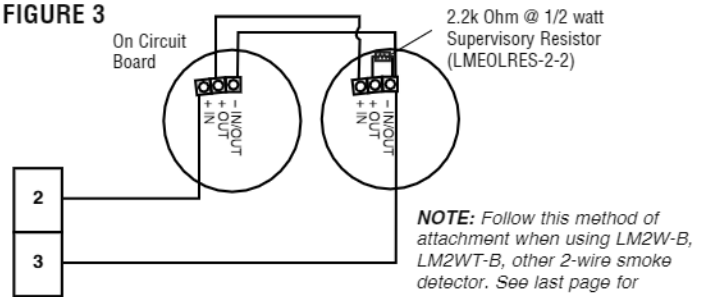

FIGURE 4

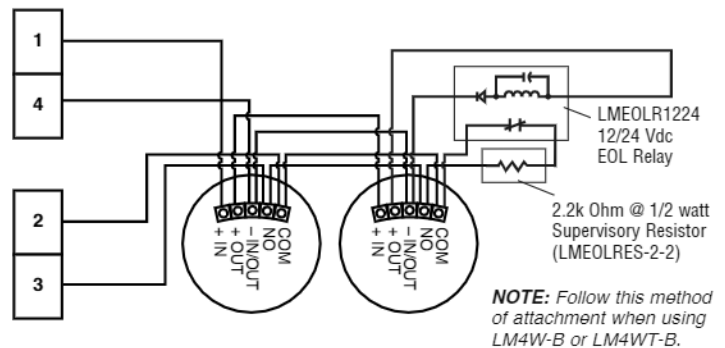

FIGURE 5

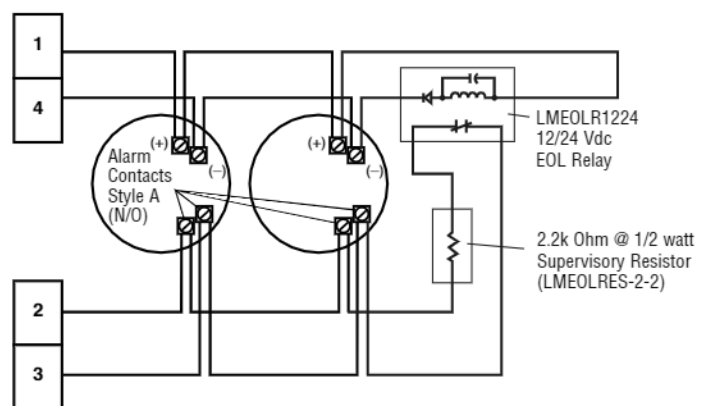
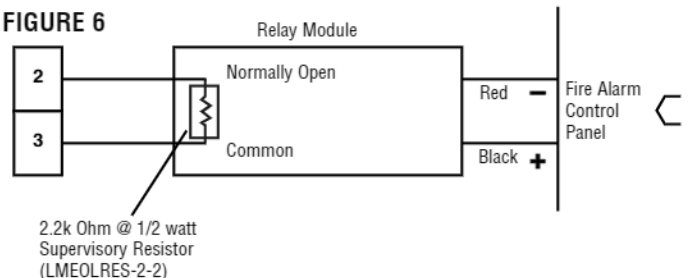

FIGURE 6



OPTIONAL CONNECTIONS

WALL MOUNTED REMOTE TEST / RESET SWITCH

The provided LMRT-OHD switch should be wall mounted using a single gang junction box at approx. 4' above floor level. Connections should be made between N/O contacts (red and yellow wires) on the LMRT-OHD to terminals 21 and 22 in the releasing device (Figure 9). The LMRT-OHD test / reset switch provides two functions to the releasing device:

- 1) Test Function. The releasing device can be tested by turning and holding the LMRT-OHD switch. See Testing section for details.
- 2) Alarm Resetting. The LMRT-OHD can be used to reset a latched alarm condition if the door is closed and the alarm input has returned to the standby state (alarm is no longer active). Reset can be accomplished by turning and releasing the switch. **Door may re-open automatically if auto-open feature is enabled, see DIP Switch Configuration Setting section.**

NOTE: This connection is necessary if floor level resetting of the device or Auto Opening is required.

ANNUNCIATOR

Connect annunciator (LMHS24R) to 16 (+) and 20 (-). End-of-line resistor (LMEOLRES-2-2) must be installed as illustrated (Figure 7). A maximum of two annunciators may be connected. Maximum output current of the devices must not exceed .75A dc. Route wires through the non-conductive sleeving (provided) covering any exposed bare wires. Maximum distance of wire run within conduit not to exceed 20' total. **NOTE:** If installing two visual annunciators they must be installed on opposite walls. If these inputs are not used, place the 2.2k Ohm resistor from the parts kit between terminals 16 and 20.

ADDITIONAL DRY CONTACT RELAY

An additional dry contact relay is provided between 17 (Common) and 18 (N/C) and 19 (N/O). Maximum switched current is .15A 125Vac, 1A 24Vdc. Switching of this relay occurs immediately upon sensing an alarm.

VOICE BOARD OPTION

The voice board provides one of two verbal warnings that the fire door is closing. Typically, depending on the length of the delay chosen on the release device, a warning tone will occur prior to the message, which is approximately 10 seconds in length (for example, a 20 second delay setting on the release device will result in a 10 second warning tone followed by the verbal warning message). There are two messages that may be selected:

Message 1: Warning tone followed by the message, "Warning! An emergency condition exists and this fire door is about to close; please remove any obstructions from its path and stand clear."

Message 2: Warning tone followed by the message, "Warning! This fire door will close in 10 seconds... 5 seconds... the fire door is now closing; please remove any obstructions from its path and stand clear."

CAUTION

To prevent DAMAGE to the circuit board, auxiliary limit switches MUST be provided as dry contacts and may not be used in conjunction with the simultaneous switching of a motor control or ANY other voltage through the same contacts. Connections of this type will result in immediate damage to the release device.

The release device has an 8-position DIP Switch mounted on the circuit board, and the switch at position #8 permits selection of either message. In the "ON" position, Message 1 is activated; in the "OFF" position, Message 2 is activated.

The voice board can drive up to two 70.7V speakers (Model LMSP24R) or speaker inputs to speaker strobes (Model LMSS24R). Maximum delivered power is 5 watts.

A potentiometer (VR1) is mounted on the board and rotation counterclockwise increases the volume (clockwise to decrease volume) (Figure 8).

Figure 7

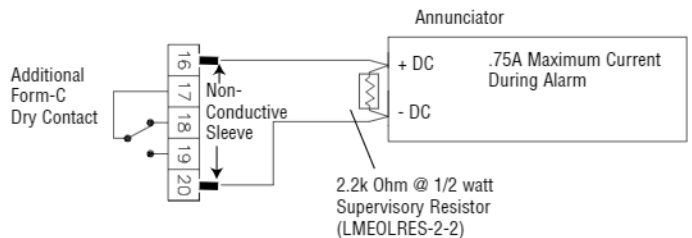

Figure 8

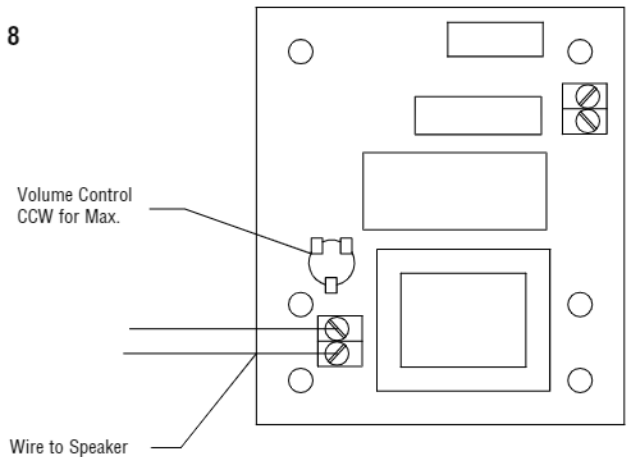
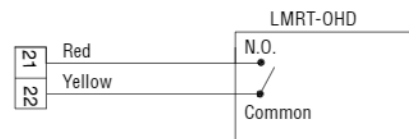

Figure 9



NOTE: LMRT-OHD key switch must be installed within a single gang junction box with a minimum 2" depth using appropriate 6-32 mounting screws and mounted on the same wall and within the same room as is the release device. All wire connections must be secured with appropriate wire nuts.

ADJUSTMENTS

DIP SWITCH CONFIGURATION SETTING

The release device has DIP switch selectable options. The options DIP switch is located next to terminal block 5. Set all DIP switch options before applying power to the system. The selection of positions is listed below.

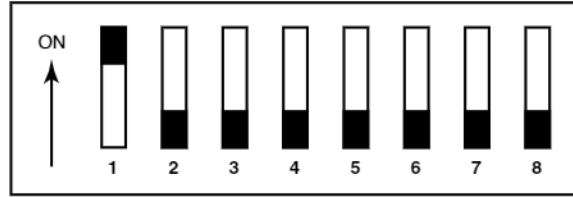

Factory default setting of 10 seconds shown.

DIP Switch	Switch "ON"	Switch "OFF"
1	Motorized door. The device will attempt to close the door with the motor before releasing.	Manual door. The device will drop the door without attempting to close it with a motor.
2	Stop on obstruction. If a motorized door is used, the device will attempt to close the door but will reverse if the safety edge is triggered. The device will stop the door on the obstruction when it is sensed the third time.	Drop after sensing an obstruction three times. The device will attempt to close the door but will reverse if the safety edge is triggered. The device will fully open the door after a third obstruction is sensed and then drop the door.
3	DIP switches 3 and 4 control the length of the delay, either 10, 20, 30 or 60 seconds depending on the switch settings.	DIP switches 3 and 4 control the length of the delay, either 10, 20, 30 or 60 seconds depending on the switch settings.
4	DIP switches 3 and 4 control the length of the delay, either 10, 20, 30 or 60 seconds depending on the switch settings.	DIP switches 3 and 4 control the length of the delay, either 10, 20, 30 or 60 seconds depending on the switch settings.
5	6-Minute safety timer. Will drop the door after 6 minutes if the close limit is not achieved by a motorized closure.	3-Minute safety timer. Will drop the door after 3 minutes if the close limit is not achieved by a motorized closure
6	Line Power Loss Alarm. Treat a loss of line power as an alarm, which leads to door closure or drop.	Operate normally from battery power when line power is lost. (Standard)
7	Auto-Open. Open a motorized door automatically after alarm condition is cleared by Remote Test / Reset Switch.	Auto-Open Disabled. Keep door closed after alarm condition is cleared. (Standard)
8	For voice board option only, this selects Message 1.	For voice board option only, this selects Message 2.

SELECTABLE DELAY SETTINGS (SWITCHES 3 & 4)

The release device will provide a factory default delay of 10 seconds before releasing the fusible link chain upon alarm. The length of the delay is controlled by the positions (Off or On) of the number 3 and 4 switches on the 8-position DIP switch mounted on the logic board. Four preset delays are available and are shown.

Delay Setting	Switch Position	
	3	4
10 Seconds	Off	Off
20 Seconds	Off	On
30 Seconds	On	Off
60 Seconds	On	On

TESTING

TESTING

Testing does not affect normal operation of alarm system when connected to release device/control panel. Testing of the release device is independent of, and shall in no way be interpreted as an alternative method of, testing of a central fire alarm system, motorized operator and/or any other system component employed on the fire door or counter fire door installation. Complete testing and normal operation can only be accomplished with power applied to device. Verify options ordered and installed with device.

TEST RELEASE DEVICE AND DOOR OPERATOR

AUTOMATIC DOOR CLOSURE TESTS (MOTORIZED DOORS ONLY)

Release Device Test Button – with AC Power

1. Clear fire door opening and prohibit traffic through door opening while testing.
2. Turn on power to release device. The Red power LED will light on the release device and the battery trouble sounder will begin to beep.
3. Connect battery leads using the included battery interconnect wire and the release device battery wires (Figure 10). Green LED will light indicating battery is connected and charging.
4. Turn on power to motor. Motor sense disable Yellow LED will light indicating power is present at motor control secondary.
5. Fully open door.
6. Depress and continue to hold the test button on the release device. The optional annunciator (or voice board) will turn on and after the preset delay the door will begin to close.
7. Release test button. The test is complete. The door will re-open if Auto-Open feature is enabled, see DIP Switch Configuration Setting.
8. Depress "Open" button on door control to raise door to open position if required.

⚠ WARNING

To prevent possible SERIOUS INJURY or DEATH:

- Clear fire door opening and prohibit traffic through door opening while testing.
- DO NOT install this device on a motorized door without an electric safety edge.
- Test every 90 days to assure proper operation of release device.

FIGURE 10

Use two 12V 4.5AH or 5.0AH sealed lead acid batteries in series. Maximum charge current 1A. Replace batteries every 2 years.

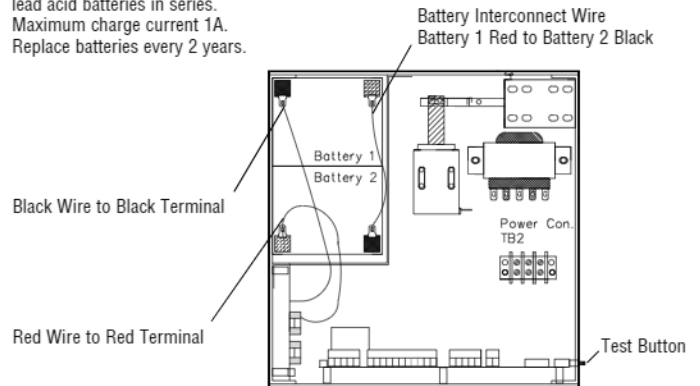

TESTING

TEST RELEASE DEVICE AND DOOR OPERATOR

AUTOMATIC DOOR CLOSURE TESTS (CONTINUED) (MOTORIZED DOORS ONLY)

Three-Cycle Obstruction Test

1. With the door fully open, place an obstruction no less than 12" in height in the normal path of the door.
2. Depress and continue to hold the test button of release device through step 4. Optional annunciator will turn on indicating a door closure is about to occur. After the preset delay the door will begin to close.
3. Upon contact with the suitable obstruction being utilized, the safety edge will reverse the operator raising the door to the open position. The release device will make three attempts to close through the operator. The release device will turn off the operator when the door reaches the open position and releases the door mechanically through the drop release mechanism. **NOTE:** *The release device can optionally be set to stop the door on the obstruction after the third triggering of the safety edge (see DIP switch options). The door will stop on the obstruction and will close fully after the obstruction is removed. The annunciator will continue to sound until the alarm condition has been cleared.*
4. Release test button. The test is complete.
5. Reset the fire door per manufacturer's instructions.
6. Reset release device by pushing in and holding the mechanical reset plunger. Insert end link through enclosure opening and release reset plunger latching the end link.
7. Depress Open button on operator control raising door to open position.

Wall Mounted Test / Reset Switch (provided)

This test disables the internal counter circuit and allows the door to continuously cycle if a suitable obstruction is utilized (refer to Three-Cycle Obstruction Test.)

1. Clear fire door opening and prohibit traffic through door opening while testing.
2. Insert key into wall mounted Test / Reset switch, turn key and hold in direction of test indicator until test is complete. Annunciator will turn on and the door will begin to close after preset delay. If no obstruction is placed in the path of the closing door, the door will fully close and the motor will turn off. If an obstruction is encountered, the door will close until it strikes the obstruction and reverse to a fully open position. The door will immediately begin to close again and continue this cycle until the key is returned to the off position.
3. Return Test / Reset switch to off position to silence the annunciator. The door will re-open if Auto-Open feature is enabled, see DIP Switch Configuration Setting.

Auxiliary Closed/Open Limit Detection Test

1. Clear fire door opening and prohibit traffic through door opening while testing.
2. Depress "Close " button on door control to close door.
3. Green Close Limit LED will be lit on Logic Board (Figure 11).
4. Depress "Open" button on door control to open door.
5. Green Open Limit LED will be lit on Logic Board (Figure 11).

TESTING

TEST RELEASE DEVICE WITH BATTERY BACKUP WITHOUT AC POWER

MECHANICAL DOOR CLOSURE TEST

This test verifies a mechanical release in absence of power to the operator. **NOTE:** *This test requires mechanical door resetting per manufacturer's instructions before returning the Fire Door to service.*

1. Clear fire door opening and prohibit traffic through door opening while testing.
2. Fully open door. Disconnect power to operator and release device. **NOTE:** *Batteries must be connected and the Green LED must be lit, if not door will release (close).*
3. The mechanical release disabled LED (Yellow) is off if the door is not closed. Turn and hold the Test / Reset Switch or depress and hold "Test" button on release device. Annunciator will sound indicating a door closure is about to occur and after preset time delay (refer to the Configuration Settings) device will release door. Release Test / Reset Switch.
4. Reset fire door per door manufacturer's instructions, then reset device release mechanism by pressing mechanical reset plunger. Fully insert end link through release device side opening and release mechanical reset plunger to latch end link.
5. Restore power to the operator and the release device. Red LED should light on the release device indicating power has been restored
6. Raise door to its fully open position. Press the "Reset" button on the device.
7. After completing all tests, verify that door is in its normal condition (open or closed) and that all power required for normal operation is restored to device and operator. The device is designed to operate with its primary power source applied.

TROUBLESHOOTING

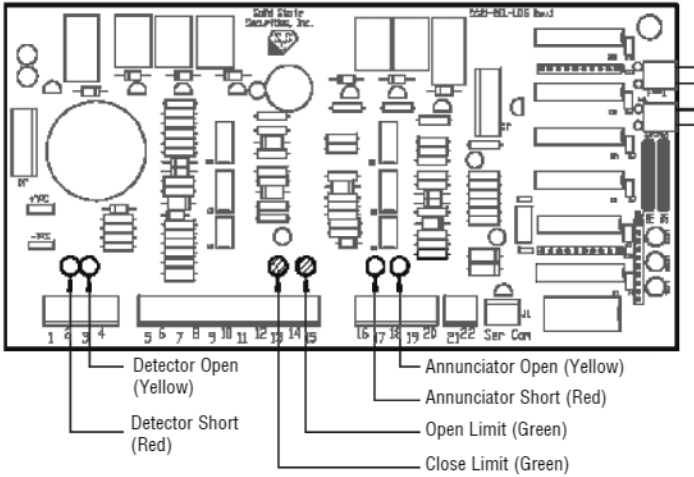

FIGURE 11 - LOGIC BOARD LED DESCRIPTIONS

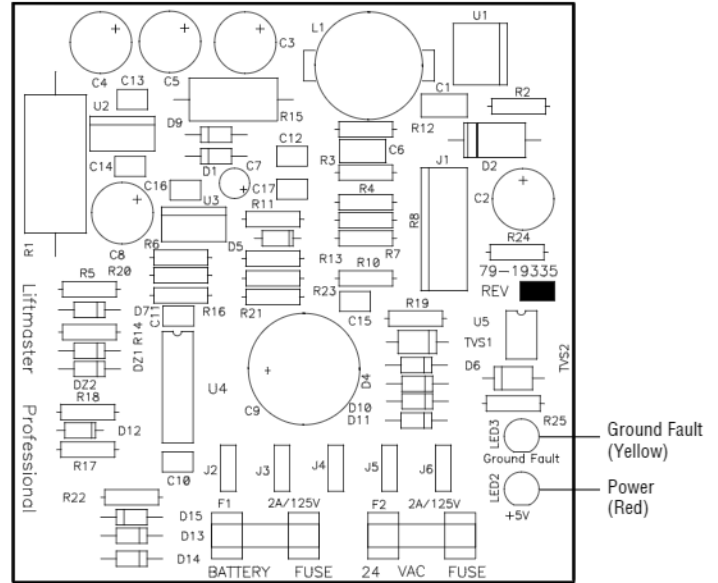

FIGURE 12 - POWER SUPPLY BOARD LED DESCRIPTIONS

DIAGNOSTIC LEDS

LED	LED Color	Description	Action Required
Battery Present	Green (Fig. 13)	If lit, batteries have been installed correctly and are charging or have been fully charged.	If the LED does not come back on after installing the batteries, check battery connections are as illustrated.
Open Limit	Green (Fig. 11)	If lit, the device senses a triggered normally open limit switch.	If door is on the Open limit, input is connected properly. If door is not on the Open limit, check that auxiliary limit connections are made as illustrated.
Close Limit	Green (Fig. 11)	If lit, the device senses a triggered normally close limit switch.	If door is on the Close limit, input is connected properly. If door is not on the Close limit, check that auxiliary limit connections are made as illustrated.
Mechanical Release Disabled	Yellow (Fig. 13)	If lit, the device is in a state where it will not release the door.	This is caused by being in close limit or by sensing an electric door operator. Check limit switch connections and motor operator control voltage connections.
Annunciator Open	Yellow (Fig. 11)	If lit, 2.2k Ohm resistor is not installed on the annunciator circuit. Note that LED lights when system is in alarm condition.	Check that the annunciator is installed as described in Wiring Instructions.
Detector Open	Yellow (Fig. 11)	If lit, 2.2k Ohm resistor is not installed on the smoke detector circuit.	Check that a 2.2k Ohm resistor is connected in the circuit as illustrated.
Ground Fault	Yellow (Fig. 12)	If lit, a short to earth ground exists.	Check that release device and all ancillary devices/loops (detectors, annunciators, etc.) are grounded properly.
Annunciator Short	Red (Fig. 11)	If lit, the annunciator circuit is short-circuited.	Check that the annunciator is installed as described in Wiring Instructions.
Line Power Present	Red (Fig. 13)	If lit, the line power is connected and switched "on."	If the LED does not light when power is applied, check that the power is connected to L1 and L2 as described in Wiring Instructions.
Detector Short	Red (Fig. 11)	If lit, the smoke detector circuit is short-circuited.	Check that the smoke detectors are connected in the circuit as illustrated. Press the "Reset" button to reset the detectors.

MAINTENANCE

MAINTENANCE

The release device has no scheduled maintenance requirements. The device has been designed and tested for use in dry, indoor locations. Testing of the device at least once every 90 days is recommended, but test intervals shall ultimately be subject to criteria established by the Authority Having Jurisdiction (AHJ).

FUSE REPLACEMENT PROCEDURE AND REPAIR PARTS

The fuse present at position F1 limits the amount of current coming into and going from the battery. The device is shipped with the fuses installed and replacement fuses (2) are provided in a separate parts bag.

For replacement parts, refer to Accessories and Replacement Parts page.

BATTERY MAINTENANCE/TESTING

No maintenance or testing is required for the battery. An audible warning tone, generated by the trouble annunciator, will sound when the battery is approaching the minimum operating threshold. This indicates the need to replace the battery. Replace the batteries every 2 years.

For replacement parts, refer to Accessories and Replacement Parts page.

BATTERY DISPOSAL

Spent batteries must be treated as hazardous waste and disposed of in accordance with State, Local and Federal Regulations.

WARNING

To avoid **SERIOUS PERSONAL INJURY** or **DEATH** from electrocution, disconnect **ALL** electric and battery power **BEFORE** performing **ANY** maintenance.

FIGURE 13

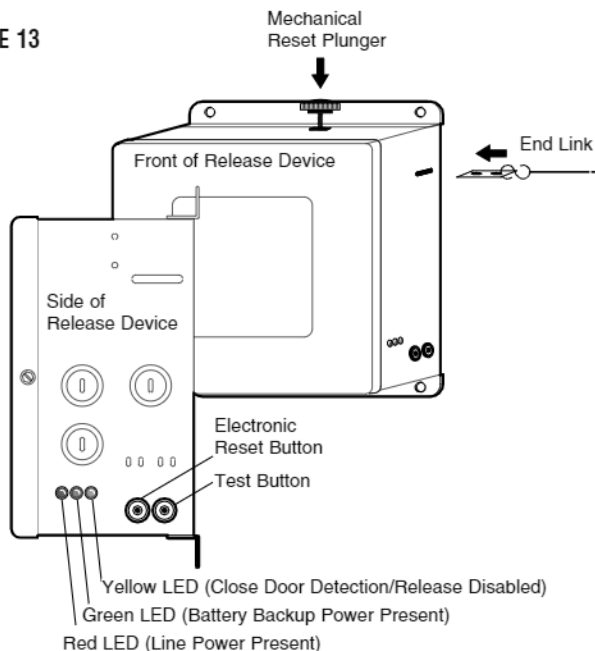

ENCLOSURE MOUNTED LEDS STATUS INDICATORS

LED Label	LED Color	Description	Action Required
Battery	Green (Fig. 13)	If the Green LED is lit, then the battery is connected properly and charged above the minimum acceptable level.	If the LED does not light, check that the leads are connected to the battery as shown on the wiring diagram in this manual. Check Battery Fuse, F1 (Fig. 12).
Disable	Yellow (Fig. 13)	If the Yellow LED is lit, the releasing device will attempt to close through the operator and not perform a mechanical release door closure in alarm. It should light if the operator control voltage is connected or the auxiliary close limit is active	Connect operator control voltage connections to terminals 11, 12 and auxiliary close limit connections to terminals 13, 14.
Power	Red (Fig. 13)	If the Red LED is lit, then the line power is connected and switched "on."	If the LED does not light when power is applied, check that power is connected as described in the installation manual electrical connections. Check 24Vac Fuse, F2, (Fig. 12).

ACCESSORIES AND REPLACEMENT PARTS

ACCESSORIES

ITEM PART #	DESCRIPTION	ITEM PART #	DESCRIPTION
1 LM8100	Smoke Detector - 120V Photo	11 LMSS24R	Speaker Strobe - 24Vdc
2 LM8100T	Smoke Detector - 120V Photo with Thermal	12 LMS24R	Strobe - 24Vdc
3 LM8100I	Smoke Detector - 120V Ion	13 LMHS24R	Horn/Strobe - 24Vdc
4 LM2W-B	Smoke Detector - 12/24Vdc 2-Wire Photo	14 LMH24R	Horn - 24Vdc
5 LM2WT-B	Smoke Detector - 12/24Vdc 2-Wire Photo with Thermal	15 LMPSTR1V75ADA	Speaker Strobe - 120Vac
6 LM4W-B	Smoke Detector - 12/24Vdc 4-Wire Photo	16 LML1V750ADA	Strobe - 120Vac
7 LM4WT-B	Smoke Detector - 12/24Vdc 4-Wire Photo with Thermal and Form C Relay	17 LMHS1V75ADA	Horn/Strobe - 120Vac
8 LM1412	Smoke Detector - 12Vdc Ion	18 LMEH120ADA	Horn - 120Vac
9 LMTH135	Heat Detector - 135 Degree Fixed Temperature	19 LMSP24R	Speaker 8"
10 LMTH194	Heat Detector - 194 Degree Fixed Temperature	20 LMEOLR1224	End-of-Line Relay - 12/24Vdc
		21 LMEOLR120	End-of-Line Relay - 120Vac

REPLACEMENT PARTS

ITEM PART #	DESCRIPTION
1 LMRK	Reset Knob
2 LMELH	End Link
3 01-32674	Owner's Manual
4 LM2AG2AMP	Fuse - 2Amp
5 LMRT-OHD	Remote Test / Reset Switch
6 LMEOLRES-2-2	End-of-Line Resistor, 2.2 kOhm
7 LM4AH12	Battery

NOTE: Certain accessories above will require a separate power source. Refer to product manual.

HOW TO ORDER REPAIR PARTS

OUR LARGE SERVICE ORGANIZATION SPANS AMERICA

Installation and service information
call our TOLL FREE number:

1-888-528-7870

APPENDIX

ACCESSORY COMPATIBILITY GUIDE

SMOKE DETECTORS

MODEL NO.	DESCRIPTION	SYSTEM SENSOR MODEL NO.	
LM2W-B	24Vdc 2-Wire Photo	2W-B	
LM2WT-B	24Vdc 2-Wire Photo with Thermal	2WT-B	
LM4W-B	24Vdc 4-Wire Photo	4W-B	
LM4WT-B	24Vdc 4-Wire Photo with Thermal & Form C Relay	4WT-B	

HEAT DETECTORS

MODEL NO.	DESCRIPTION	CHEMTRONICS MODEL NO.	SYSTEM SENSOR MODEL NO.	EDWARDS SYSTEM TECHNOLOGY (EST) MODEL NO.
LMTH135	135 Degree Fixed Temperature	#603	#5603	#283B-PL
LMTH194	194 Degree Fixed Temperature	#604	#5604	#284B-PL

NOTIFICATION DEVICES

MODEL NO.	DESCRIPTION	SYSTEM SENSOR MODEL NO.	
LMSS24R	24Vdc Speaker Strobe, Red, Fire	SP2R1224MC, SPSRL	
LMS24R	24Vdc Strobe, Red, Fire	S1224MC, SRL	
LMHS24R	24Vdc Horn/Strobe, Red, Fire, 2W	P1224MC, P2R, P2RL	
LMH24R	24Vdc Horn, Red	H12/24, HRL	
LMSP24R	Speaker, Red	SP201R, SPRL	

END-OF-LINE DEVICE

MODEL NO.	DESCRIPTION	SYSTEM SENSOR MODEL NO.	SPACE AGE ELECTRONICS NO.	LIFTMASTER NO.
LMEOLRES-2-2	2.2 kOhm End-of-Line Resistor			LMEOLRES-2-2
LMEOLR1224	End-of-Line Device	EOLR-1		
LMEOLR120	End-of-Line Device		PAM-1	

NOTE: Certain accessories above will require a separate power source. Refer to product manual.