

LINEAR™

Entry Pro Series

Entry Pro Installation Manual



EP Series Hardware Installation Manual

Table of Contents

Introduction	1
Feature Overview	2
Hardware Features	2
Installation Overview Checklist	3
Output Defaults	3
System Input Wiring Defaults	3
System Diagnostics	4
Accessory Overview	5
Wiegand Devices	5
Component Locations	6
Wiring Diagram	7
Mounting Requirements for EP Series Units	8
Entry System Mounting	9
System Output Overview	12
Wiring - Best Practices	12
System Input Wiring	15
System Input Wiring	15
Wiegand Reader	17
Telephone Wiring	18
Operational Postal Lock	19
Optional Internal Card	20
CPU Board Indicators	25
Internal Controls	26
Dimensional Drawing – EP - 4xx	27
Dimensional Drawing – EP - 7xx	28
Troubleshooting	29
Specifications	30
Unit Operation	30
Limited Warranty	32
FCC Notice	32

Introduction

Linear's Entry Pro (EP) Telephone Entry & Access Control System is designed for use as a primary access control device for gated communities, parking garages, office buildings, apartments, dormitories, hotels/motels, commercial buildings and recreational facilities.

The EP Telephone Entry and Access Control system provides considerable advantages over legacy RS485 daisy-chained systems. These networked systems can provide shared programming and user information, remote accessibility and enhanced scalability for large complex installations.

The system is housed in a locked enclosure, featuring a stainless-steel back-lit keypad with bright, easy-to-read graphics, a 4.3" color LCD directory display or 7" Touch Screen with programmable welcome message, a built-in microphone and speaker, and an ADA compliant TTY jack for use by the hearing impaired. The system also has provisions for an internally mounted card reader and a U.S.P.S. supplied postal lock. Cabinet security is monitored with a mechanical "tamper" switch.

The unit houses four relays; two can be programmed to control electric door strikes, magnetic locks, door and gate operators or barrier gates. The other two can be programmed for auxiliary options, such as a propped door alarm.

The system provides telephone communications between visitors and residents for granting access. Complete access control event logging, access time restriction, access location restriction, and administration functions are also available to manage the installation.

The EP-xx2 models are standalone units, but they can be upgraded to interconnect with other EP-x36 and EXN modules. Multiple EP units can be networked together to share one common database for larger multi-access installations.

NOTE: *There should only be one Access Control server database in a networked multi-system installation. In this situation, the EP-xxx unit can be reconfigured to be a client instead of a server. See the License-TO-Go document included for information on this process.*

Operation

In a typical installation, the unit is programmed with each resident's name and directory code number. Arriving visitors use the keypad on the unit to view the directory names. When selecting the resident, the unit will dial the resident's telephone number and establish two-way voice communication between the visitor and the resident.

The resident will then have the option to grant or deny access to the visitor by pressing the phone's 9 key or deny access by ending the call. In addition to the telephone entry, the unit can grant access using entry codes at the local or remote keypads. Also, remote receivers, card readers, and interior and exterior keypads can be used with the system.

MegaCode® remote transmitters can be used to gain access through the included radio receiver. Each transmitter can be individually suspended or re-activated. The system's clock/calendar can control access based on specific times and dates. Automatic relay activation can be scheduled. Access can be restricted to certain times and dates. Holiday access can be scheduled. The system's event log records system activity for future reference.

Programming and Cardholder Maintenance

After initial configuration, system programming and maintenance can be performed locally or remotely over a network connection.

Feature Overview

Relay Outputs

Two 5-amp dry contact Form-C SPDT relay outputs are provided to activate access devices, such as door strikes, magnetic locks, automatic doors, barrier gates, and automatic sliding gates. Two Auxiliary outputs can also be used as specialty outputs for alarm contact shunting and alarm activation. Each of the relays can also be manually activated from buttons on the unit's interface circuit board. These buttons also provide manual override to allow doors/gates to remain open (Construction Mode) when necessary. LED indicators display the status of each relay.

Request-to-Exit (REX) Inputs

Each door lock relay channel has a request-to-exit input. These inputs are supplied for hard wire activation of the access devices. Typically a request-to-exit input is wired to a pushbutton inside of the access controlled area. When a person desires to exit, pressing the pushbutton will activate the output relay channel and trigger the access device. A loop detector for automatic gate operation can be connected to a request-to-exit input. The inputs are also selectable NO, NC and/or supervised.

Door Switch Monitor (DSM) Inputs

The door switch monitor inputs connect to door switches that monitor whether the controlled door is open or closed. As an option, REX can be electronically over-ridden in the software.

Wiegand Reader Support

The unit's four Wiegand inputs (READER #1 & READER #2) can connect to Wiegand output accessories capable of reading up to 64 bit formats. The system offers a Wiegand code decoder and most formats are offered and can be configured to use existing credentials. The Wiegand format is a common standard for access control equipment. A typical application would be to add swipe card or proximity readers to the system.

Local Keypad

The local keypad is the system's primary keypad. The local keypad activates Door Lock Relay "A".

Postal Lock

The unit's cabinet has provisions for installing a U.S.P.S. postal lock for keyed mail carrier access. The postal lock will activate Door Lock Relay "A", but can be programmed for any of the relays. This feature also allows for Access Levels to be applied for added security.

Removable Programming Memory

The unit's removable 16GB SD card memory retains all entry codes, transmitter information, user event data, card access, and programming.

Power Management

The unit is a 9-15 VDC system with minimum power of 2amp, (ISD is powered with a 12 VDC PIP) and can be powered with a plug-in power supply, or by using the Power Distribution Module (PDM). If an AC power failure occurs, the Power Distribution Module (optional-not included) will notify the system.

Normal system power is 11-13VDC and should be measured at the power input connector with a DVOM with power plugged in and system powered up.

Network Support

Multiple EN-4xx, EN-7xx and EXN units can be networked together via individual Ethernet cables connected to a network. A common event log is retained for all of the networked units. For redundant system backup, a computer connected through the network can store and retrieve the memory data.

Unit Access

Each EP Series unit has a three-point locking mechanism with a weather-tight male and female gasket designed door requiring 6 pounds of pressure to securely close and open. When opening the cabinet, the primary hinge is more flexible than a solid continuous hinge. This design eliminates requirements for special hardware or single purpose housings, allowing the EP Series unit multiple surface and flush mount variations.

Hardware Features

- **FOUR FORM "C" (NO & NC) RELAYS**
Each relay has 5-amp @ 24-volt rating
Two assigned for lock functions
Two are assignable but default for prop door
- **TWO DOOR SWITCH MONITOR (DSM) INPUTS**
For sensing access controlled door position to detect door-ajar condition and for activating auxiliary output alarm features
- **TWO REQUEST-TO-EXIT (REX) INPUTS**
Activates access device for exiting using a hard wired switch
- **TWO AUXILIARY INPUTS**
Activates auxiliary relay outputs
Assignable to monitor NO/NC/Supervised or non-supervised devices
- **FOUR WIEGAND INPUTS**
Two Door / Portal 4, Wiegand card reader (with In and Out per door) connections to external Wiegand devices
- **INTERNAL CARD READER SUPPORT**
Card reader can mount inside front panel
- **BUILT-IN SPEAKER**
Sounds tones during keystrokes and for two-way voice communication
- **BUILT-IN MODEM**
Modem is included for telephony management of the the system
- **SD CARD MEMORY**
Removable SD memory card retains Cardholder and configuration information
- **TCP/IP Network Support**
Multiple units can be connected to a hub to share data and transactions
- **ON-BOARD CLOCK/CALENDAR CIRCUIT**
Stamps the event log data as it is stored in the system's memory
- **POWER FAILURE MONITOR**
If the optional Power Distribution Module installed, the AC power input is monitored and power outages are recorded in the event log
- **UPGRADABLE SECURITY MEASURES**
Stock locking mechanism can be replaced with unique key tumbler.
Connect tampering sensor integration with 24hr alarm circuit.

Installation Overview Checklist

The following list outlines the steps required for successfully installing an EP Series Telephone Entry System unit.

- Mount the enclosure
- Add up power consumption of all devices connected to system for Power Load Calculation
- Install the Power Distribution Module (optional)
- Connect the outputs and inputs for the access devices
- Connect the Wiegand reader
- Connect the telephone line
- Install an postal lock and card reader (optional)
- Wire an Ethernet cable for PC or LAN connectivity and management.
- Connect power to the system
- Connect an Ethernet cable to the RJ45 port on the EP for local configuration.
- Obtain IP address and other TCP/IP information from network administrator and configure the network settings for the system
- Connect the local LAN or WAN port to the local area network

NOTE: Wiring methods shall be in accordance with the National Electrical Code ANSI/NFPA 70 and all local codes.

Output Defaults

All outputs are assigned default features that can be configured as needed. The following table shows the default states for each of the two output types:

OUTPUT	DEFAULT STATE	DEFAULT RESPONSE
Door lock outputs	Not energized, single pulse	Three (3) Second unlock time in response to corresponding reader activity reader #1 input Activates door relay "a" Reader #2 input activates door relay "b"
Auxiliary outputs	Not energized, single pulse	No default response Must be configured via programming.

System Input Wiring Defaults

Systems have the three types of switch inputs used for monitoring door position (DSM), exit requests (REX), and auxiliary requests. All inputs are assigned default features that can be configured as needed. The following table shows the default states for each of the inputs:

INPUT	DEFAULT STATE
Door switch monitor (DSM)	Normally open unsupervised Eight (8) second held open time
Request to exit (REX)	Normally open momentary Unsupervised
Auxiliary inputs	Normally open Unsupervised

System Diagnostics

LED indicators on the I/O Board and CPU Board are for monitoring the system during operation. When calling for technical assistance, the Technical Services Department may ask the installer to use these indicators to diagnose the system.

I/O Board & Modem Indicators

33 LED indicators are on the I/O Board. Refer to the figure for the location of each indicator.

- **READER POWER** lights showing power is being supplied to Reader #1 or Reader #2.
- **INVALID CARD** lights when a credential's data read is not a valid data string.
- **ACCESS GRANTED** lights when a credential has been successfully decoded and the Cardholder has been granted access.
- **ACCESS DENIED** lights when a credential has been successfully decoded and the Cardholder has been denied access.
- **DOOR "A" DSM** lights when Door Relay "A" Door Switch Monitor input is activated.
- **DOOR "A" REX** lights when Door "A" Request-to-Exit input is activated.
- **DOOR "A" AUX** lights when Door "A" auxiliary input is activated.
- **DOOR "B" DSM** lights when Door Relay "B" Door Switch Monitor input is activated.
- **DOOR "B" REX** lights when Door "B" Request-to-Exit input is activated.
- **DOOR "B" AUX** lights when Door "B" auxiliary input is activated.
- **DOOR "A" LOCK RELAY** lights when Door Lock Relay "A" is energized.
- **DOOR "A" AUX RELAY** lights when Door Auxiliary Relay "A" is energized.
- **DOOR "B" LOCK RELAY** lights when Door Lock Relay "B" is energized.
- **DOOR "B" AUX RELAY** lights when Door Auxiliary Relay "B" is energized.
- **COMMUNICATIONS ERROR** lights when there is network error.
- **RELAY MANUAL** lights when a relay has been activated manually.
- **MODEM POWER** lights when the telephone modem has power.
- **USB ENABLED** lights when the USB Port has been enabled.
- **HEARTBEAT** lights when the system is live and running.
- **POWER GOOD** lights when system power is within specification.
- **POWER ON** lights when the system is receiving power.
- **BOOT** lights during system reboot.
- **RESET** lights during system reboot.
- **PERIPHERAL "A" TRAFFIC** lights during Peripheral "A" traffic.
- **PERIPHERAL "B" TRAFFIC** lights during Peripheral "B" traffic.

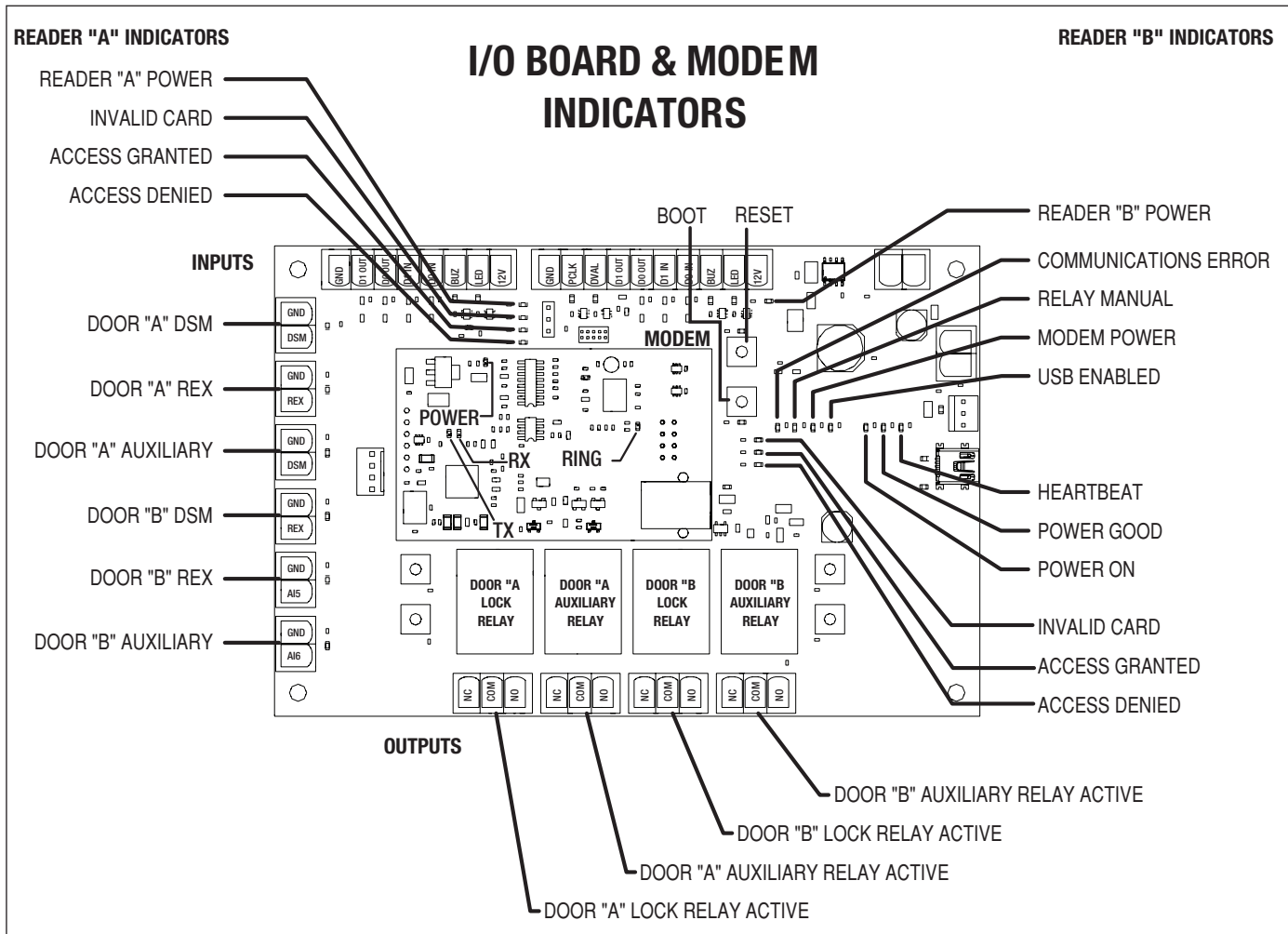

Accessory Overview

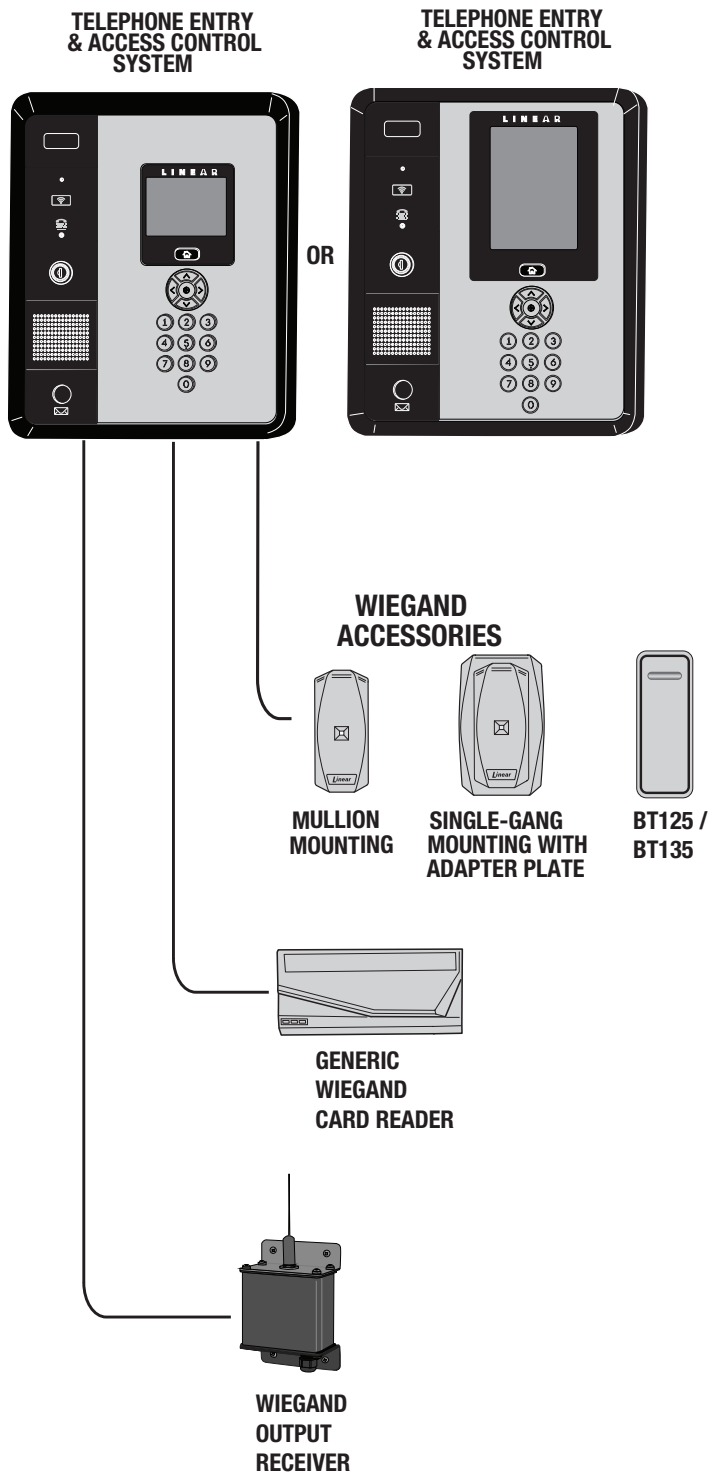

Wiegand Devices

The two WIEGAND format inputs are available to connect WIEGAND devices. Virtually all 26 through 64 bit WIEGAND output devices from other manufacturers can be used with EP Series units.

SINGLE-GANG MOUNTING WITH ADAPTER PLATE

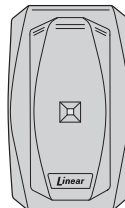

2N1 Reader

2N1 Reader

The 2N1 reader is a 125kHz Multi-Protocol Reader with RFID technology. Supports certain HID, AWID & Farpoint 125 kHz proximity protocols. Mullion and Single-Gang (Shown) mounting options.

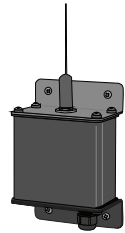

WOR

Wiegand Output Receiver (WOR)

The WOR is used as a wireless access control interface for block coded digital transmitters. It receives signals from transmitters, adds a facility code to the data, and sends the information via a 5-wire connection to a Wiegand input commonly available on most access control panels.

Component Locations

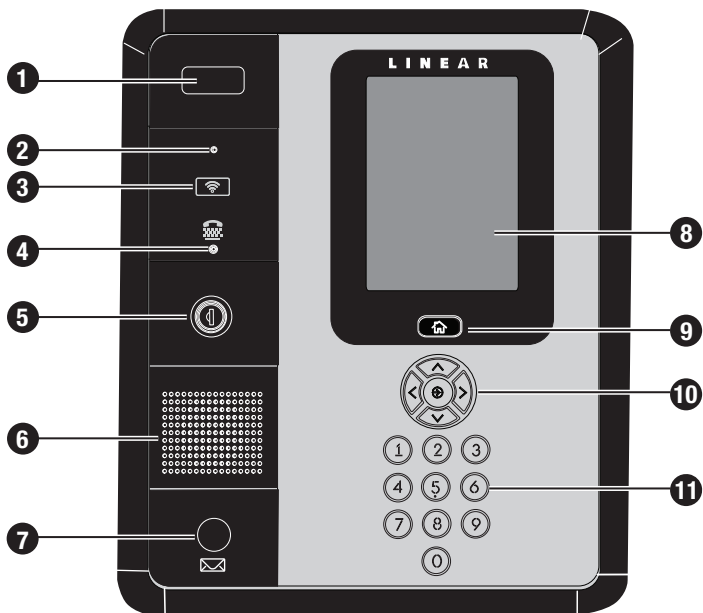

1. Optional Camera
2. Microphone
3. Optional Proximity Sensor
4. TTY Jack
5. Cabinet Lock
6. Speaker
7. Optional Postal Lock
8. Touch Screen Display (EP-736 only)
9. Home Button
10. Navigation Keys
11. Lighted Panel
12. Pedestal Mounting Holes
13. Relay Outputs
14. 3-Point Locking Latch
15. Door Position (DSM) Exit Request (Rex) & Auxiliary Inputs
16. Input/Output Board
17. Reader "A" (Weigand)
18. Reader "B" Type Jumper
19. Reader "B" (Weigand)
20. Power Input 12 VDC
21. Power Fault Input
22. Camera Power
23. SD Memory Card Slot
24. CPU Board
25. Tamper Input
26. USB Port
27. Light Sensor Board
28. Tamper Switch
29. 3-Point Locking Tab
30. Microphone
31. Brackets for Optional Prox Reader
32. TTY Jack
33. Cabinet Lock
34. Speaker
35. 3 Point Locking Tab
36. Postal Lock Cover
37. RJ45 LAN Port
38. Lock Switch
39. Mic Input Postal
40. Speaker Input
41. Postal Lock Input
42. Keypad Board
43. USB to I/O
44. Earth Ground Stud

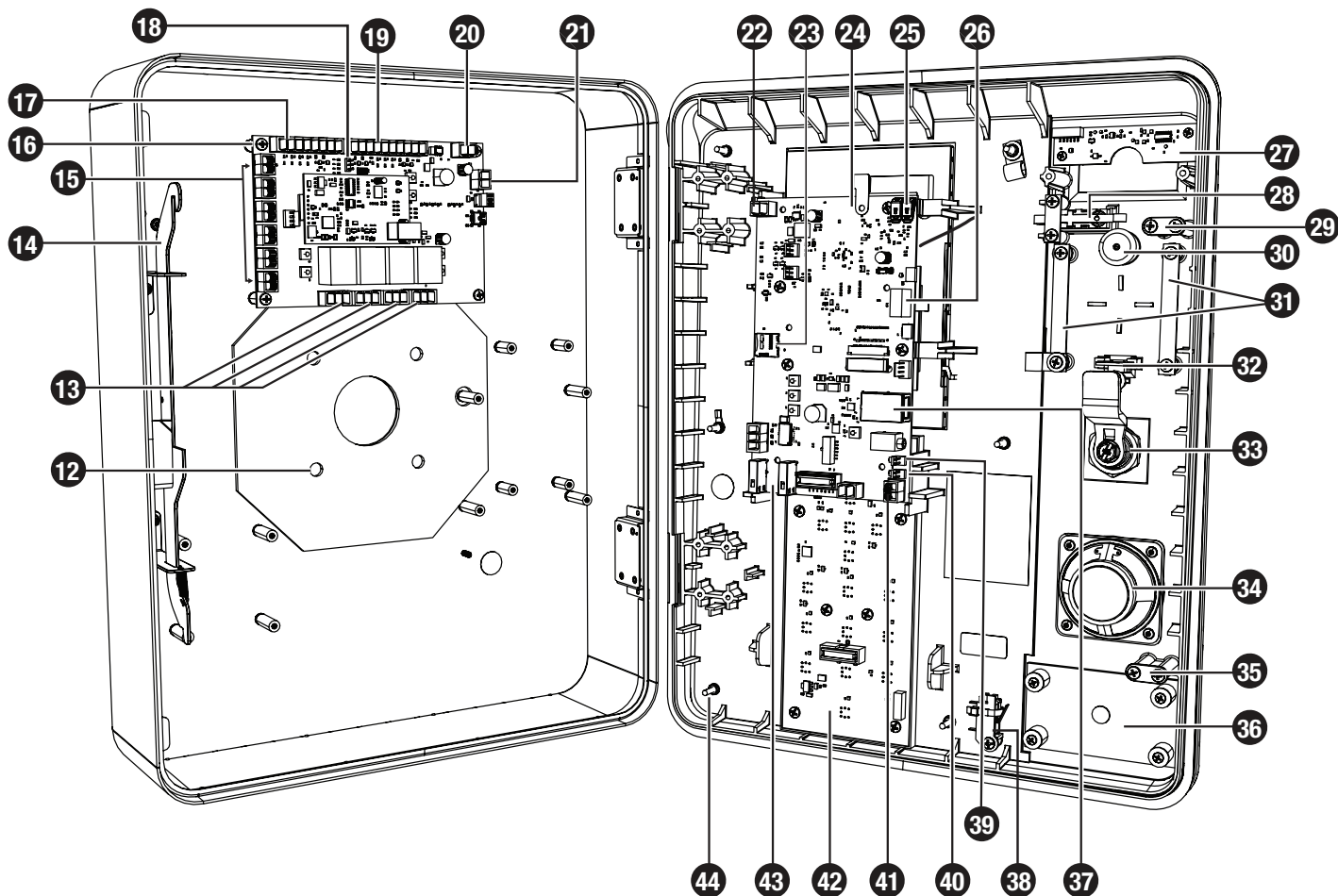

Wiring Diagram

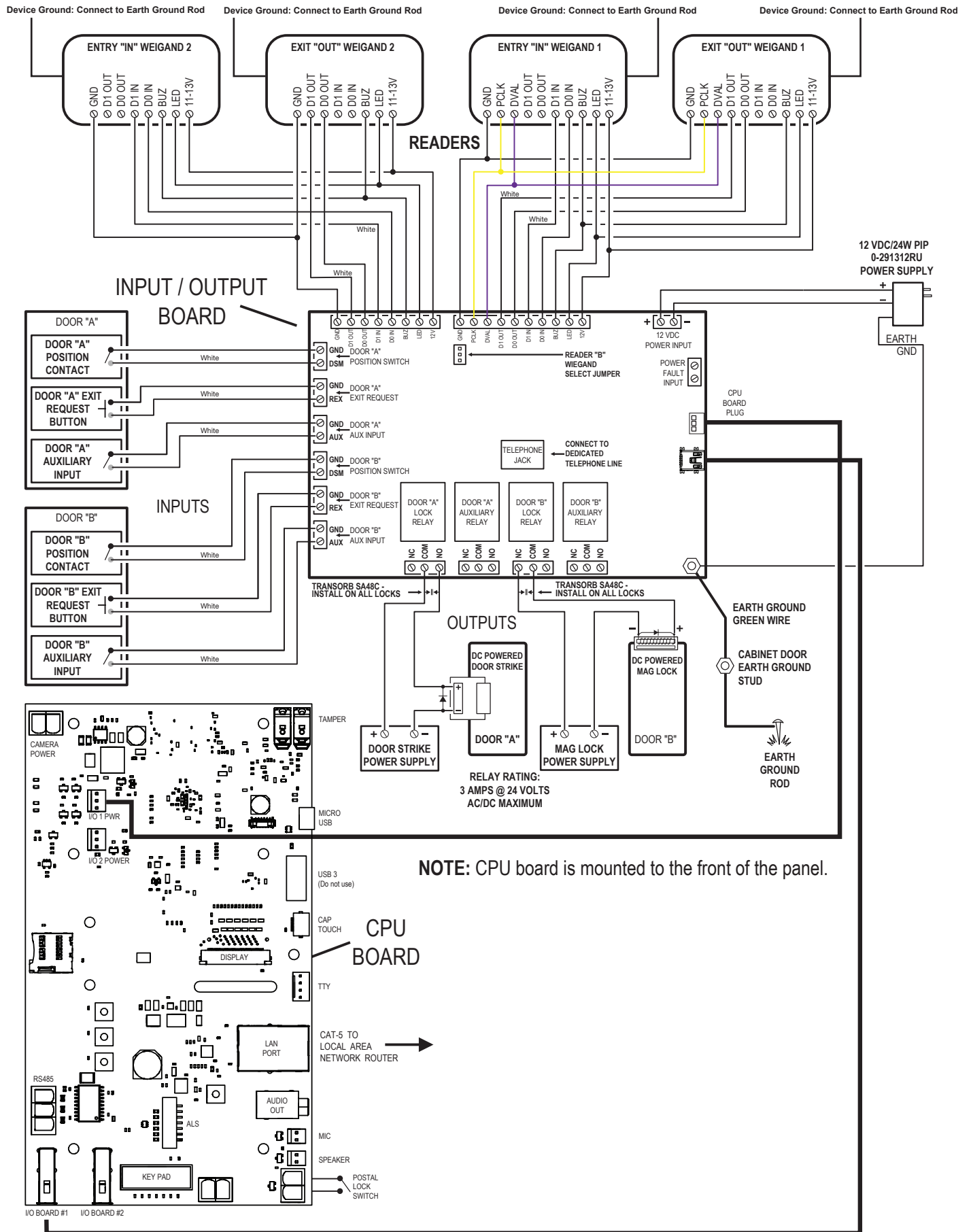

Mounting Requirements for EP Series Units

The EP Series Telephone Entry & Access Control System can be installed for public or private use. The mounting requirements will vary depending on the installation. Review the following information before beginning the installation.

Mounting Environment

Consider the environmental factors at the desired mounting location. The unit is designed for direct outdoor installations, however, it is preferable to protect the unit and your guests and residents from extreme exposure to sun, driving rain, or snow whenever possible. Mounting the unit in a kiosk can provide extra environmental protection.



Mounting Surface

When mounting to an uneven surface, be sure not to bolt down the housing too hard. Shims should be used to offset the uneven surface to ensure the housing is not warped when mounted.

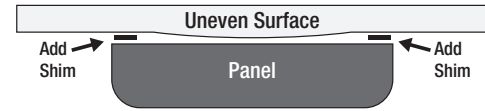

Follow Building Codes

Check all local, state, and national building codes and ordinances prior to installing the system. Proper installation of the unit conforming to the local building codes for access control equipment is a regulatory requirement. The unit's installation is an extremely important and integral part of the overall access control system. It is not designed to have direct water from drainage or water flow from roof on or behind the unit.

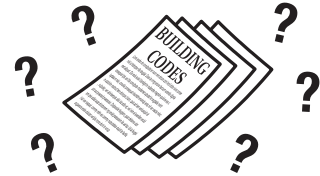

Mounting Location

If the unit is used to control a door or pedestrian gate, locate the unit as near as practical to the entry point. If the unit is mounted on or in a wall adjacent to the entry point, be sure the wall is sturdy. The repeated shock and vibration from a slamming access door or spring-loaded pedestrian gate must be isolated from the unit. Avoid drainage spouts or areas where water runs directly down wall. **NEVER MOUNT THE UNIT DIRECTLY TO A MOVING DOOR OR GATE!**

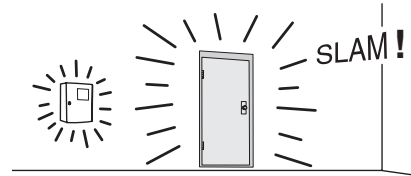

Gate Installations

If the unit is used to control a gate operator connected to a vehicular gate, the unit **MUST** be mounted **AT LEAST 10 feet** away from the gate (open and closed) and gate operator. **AT NO TIME SHOULD A PERSON BE ABLE TO TOUCH THE GATE OR GATE OPERATOR AND THE UNIT AT THE SAME TIME.**

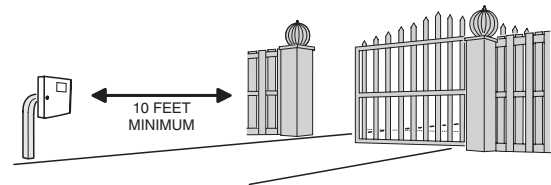

Vehicle Traffic

Do not mount the unit where it extends into any traffic lane. Locate the gooseneck pedestal or entry kiosk so all parts of the unit are outside the traffic lane. Locate the unit clear of any turn-around lanes vehicles use when access is denied.

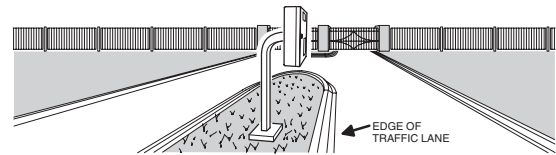

Americans with Disability Act (A.D.A.) Requirements

THE FOLLOWING WHEELCHAIR ACCESS REQUIREMENTS ARE FOR PUBLIC DOOR CONTROL INSTALLATIONS ONLY.

1. If the clear floor space allows only forward approach to the system, the maximum high forward reach allowed is 48" above grade to the top of the keypad.
2. If the high forward reach to the system is over an obstruction of greater than 20" but less than 25", the maximum high forward reach allowed is 44" above grade to the top of the keypad.
3. If the clear floor space allows parallel approach by a person in a wheelchair, the maximum high side reach shall be 54" above grade to the top of the keypad.
4. If the high side reach is over an obstruction of 24" or less, the maximum high side reach allowed is 46" above grade to the top of the keypad.



Entry System Mounting

The unit's cabinet is designed to be mounted two ways:

- The unit can be mounted directly to a wall or flat surface.
- The unit can be mounted on a standard gooseneck pedestal.

Choose a well lit location near the controlled opening. Wiring access for power, telephone, network, earth ground, and control outputs must be available to the mounting location. If the optional remote accessories are used, wiring access for these cables must also be available to the mounting location.

Surface Mounting

The cabinet can be mounted on a wall or any suitable flat surface. Use the four 3/8" mounting holes to attach the cabinet to the surface.

1. For wall mounting, hold the template at the approximate mounting location where the display will be about eye level or slightly above.
2. Using the 3/8" mounting holes, mark the four mounting hole centers. Drill as required. Use the appropriate fasteners for the mounting surface to secure the cabinet.
3. The use of a silicon seal is permitted along the top of the case where the unit meets the mounting surface (ensure that the Weep holes located along the bottom edge remain free of silicon and debris). Ensure that water runoff from building does not impact the unit.

IMPORTANT: BE CERTAIN TO INSTALL ANY PROVIDED GASKETS DURING INSTALLATION.

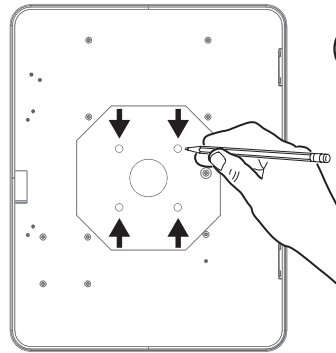

1 MARK THE (4) FOUR MOUNTING HOLES CENTERS.

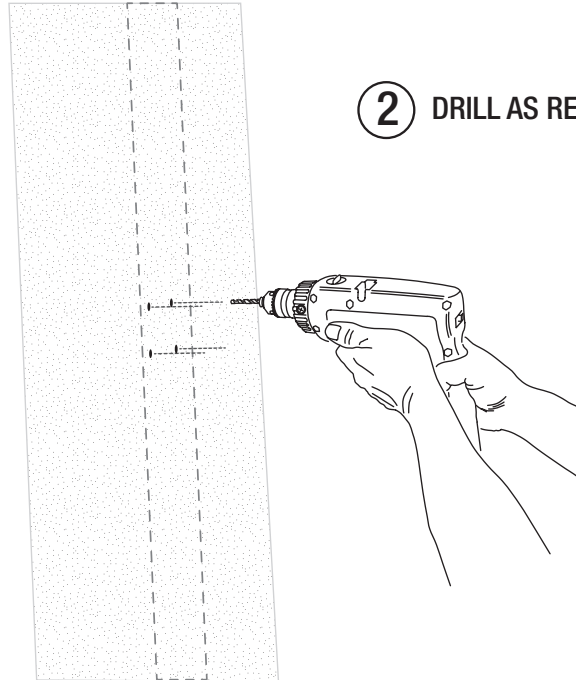

2 DRILL AS REQUIRED.

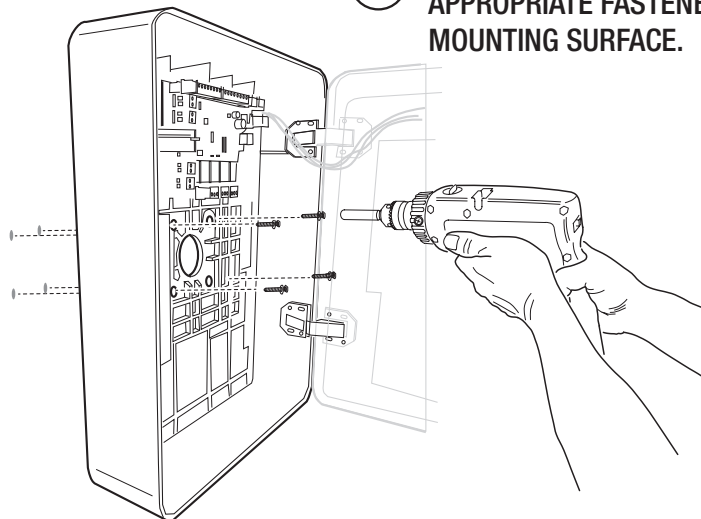

3 SECURE THE CABINET USING THE APPROPRIATE FASTENERS FOR THE MOUNTING SURFACE.

Pedestal Mounting

The cabinet can be mounted on a gooseneck pedestal. Two pedestals are available: Model GNC-1 is for surface mounting with concrete fasteners, Model GNB-1 is for burial mounting. The EP Series units are designed for installation directly to gooseneck mounts. No unique mounting plates are required.

1. Install the pedestal at the desired location.
2. Use security hardware to attach the cabinet to the pedestal.
3. Use silicon to seal any openings that could introduce water into the housing.

NOTE: No additional mounting brackets are required for the installation.

NOTE: NSC Goosenecks include gaskets for water tight connections.

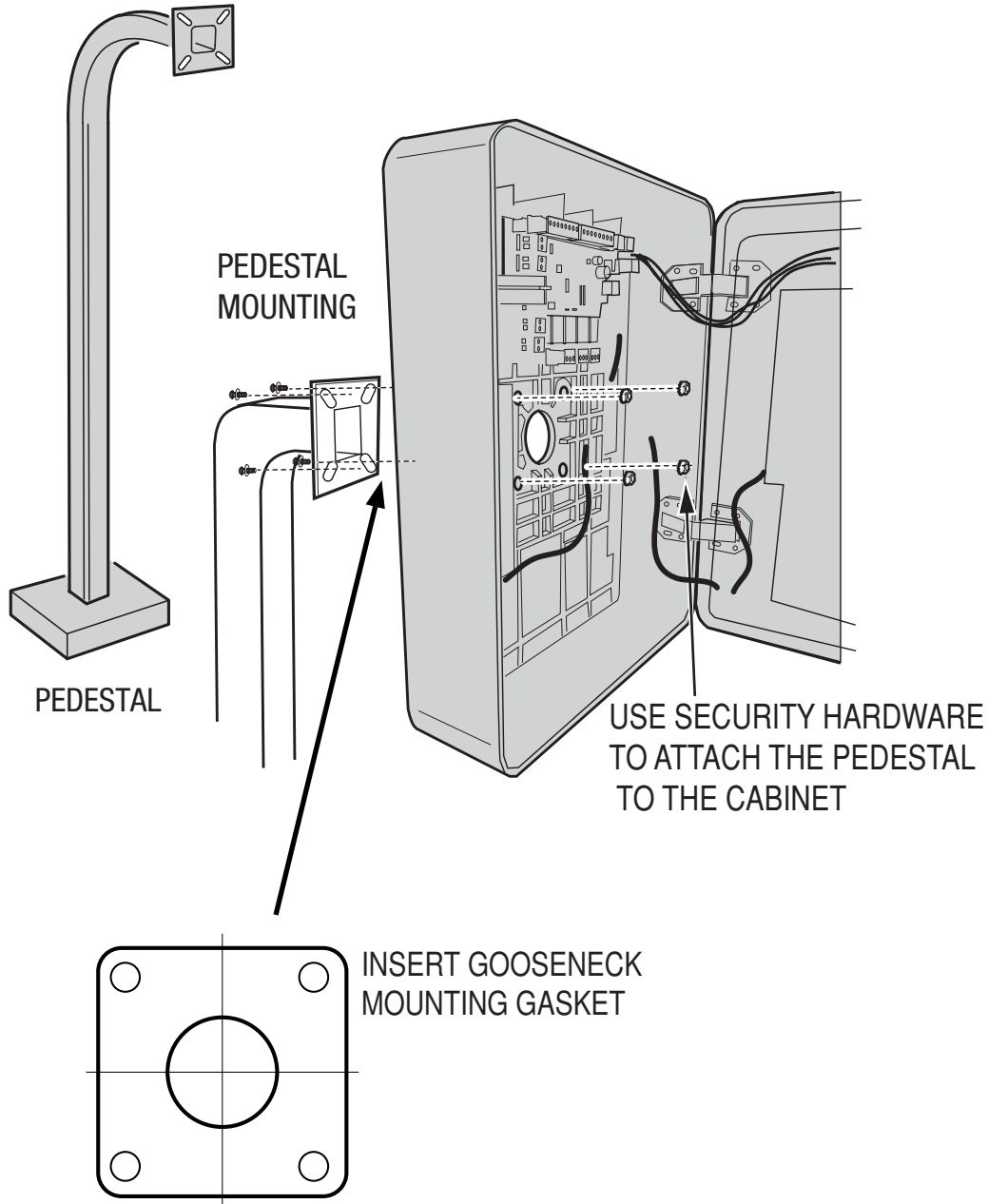

Mount to a Wood Surface Using Pedestal Mounting Holes

The cabinet can be mounted to a wood surface using the holes designed to install the Pedestal.

1. Work with the dealer to identify a stud or reinforcement beam where the housing may be attached.
2. Measure and drill holes into the beam.
3. Drive 1/4 inch wood screws with lock washers through the pedestal mounting holes to secure.
4. Use silicon to seal any openings that could introduce water into the housing.

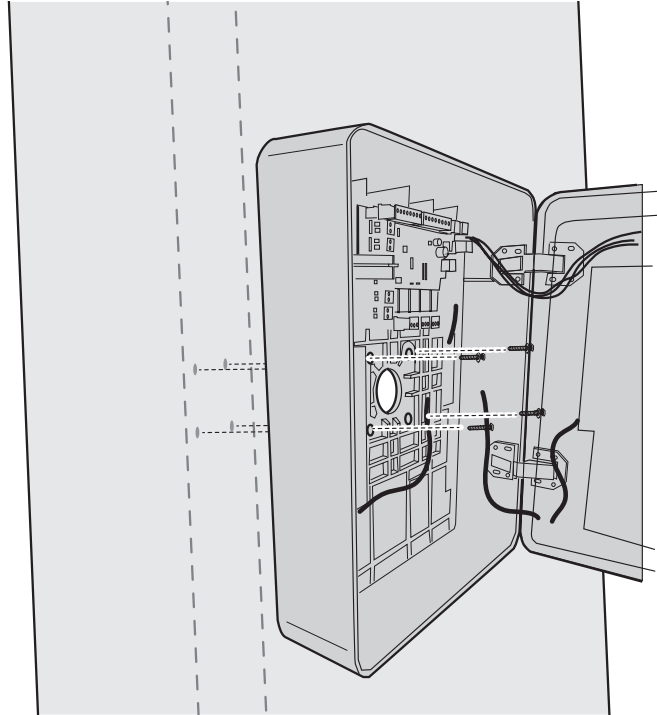

Mounting on a Rough Surface

If you're mounting the unit to a rough surface, use weather stripping to seal out moisture and debris from above.

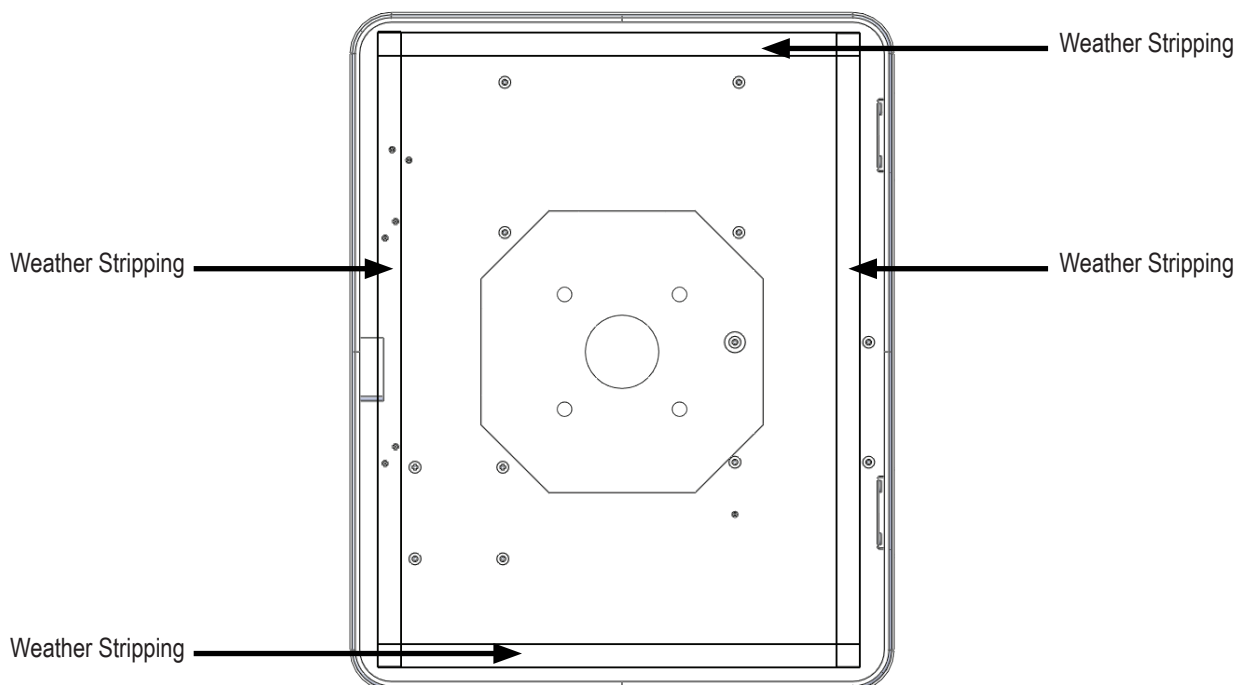

System Output Overview

The unit has two door lock relays and two auxiliary output relays that can be activated in response to reader activity, time schedules, or input conditions.

All relays are Form-C SPDT and provide non-powered dry contacts rated for 5 Amps. Power for the relay loads can come from an external power supply or from an optionally installed Power Distribution Module board.

Output Defaults

All outputs are assigned default features that can be configured as needed. The following table shows the default states for each of the two output types:

OUTPUT	DEFAULT STATE	DEFAULT RESPONSE
Door lock outputs	Not energized, single pulse	Three (3) second unlock time in response to corresponding reader activity reader #1 input Activates door relay "A" Reader #2 input activates door relay "B"
Auxiliary outputs	Not energized, single pulse	No default response Must be configured via programming.

Recommended Wiring Requirements

The power cable must be the proper gauge for the current load and should not be routed in parallel with other wiring especially high voltage or AC wiring. Refer to the table for wiring recommendations:

TOTAL AMPS	VOLTAGE (AC OR DC)	WIRING GAUGES AND DISTANCE			
		12 AWG	14 AWG	16 AWG	18 AWG
.5 AMPS	12 VOLTS	600 Feet	380 Feet	240 Feet	150 Feet
	24 VOLTS	1200 Feet	740 Feet	480 Feet	300 Feet
1.00 AMPS	12 VOLTS	300 Feet	190 Feet	120 Feet	75 Feet
	24 VOLTS	600 Feet	345 Feet	240 Feet	150 Feet
2.00 AMPS	12 VOLTS	150 Feet	95 Feet	60 Feet	35 Feet
	24 VOLTS	300 Feet	190 Feet	120 Feet	70 Feet

NOTE: Always verify power input during installation using a Digital Volt Ohm Meter (DVOM) with the power connector plugged in and the system powered up. Voltage must be in the acceptable power range of 11-13VDC. If voltage is not within range, you must verify the power source, wire gauge and cable length.

Wiring - Best Practices

1. Terminals are in a separate bag. This allows the installer to pull through the cabinet ~12' of cable and wire to the terminal not mounted to the board.
2. Make sure the cable drops down in the housing prior to connecting to the PCB. This will allow for condensation to drip to the bottom of the cabinet and not directly to the PCB boards.
3. Cabling for system ground always needs to be the correct cable type and gauge as defined for the system..
4. Be sure to use the transient protection where recommended.
5. The Entry series includes a power supply. It is not intended to power locking hardware or other devices.

Relay Wiring for Door or Pedestrian Gate Control

1. Door Lock Relays A & B can be used to control electromechanical access devices on doors. The door will unlock when a user is granted access by the system. The door will remain locked if a user is denied access (see diagram, next page).
2. The door lock relay outputs can each be configured to operate in fail-secure or fail-safe modes.
3. In fail-secure mode, a door lock relay energizes when access is granted.
4. In fail-safe mode, a door lock relay de-energizes when access is granted.

Door Strike

1. Install a low voltage electric door strike as a locking device for the door or pedestrian gate.
2. Install the power supply or transformer for the locking device. **DO NOT POWER THE UNIT FROM THIS POWER SUPPLY.**
3. Connect one wire from the power supply to one wire from the locking device.
4. Route two wires between the locking device and the unit. Connect one wire to the remaining wire of the locking device. Connect the other wire to the remaining wire of the power supply.
5. Install a protection diode (for DC door strikes) or MOV (for AC door strikes) across the strike to protect the door relay contacts.
6. Connect the wires to the unit's **DOOR LOCK RELAY COM & NO** terminals for fail secure operation or **DOOR LOCK RELAY COM & NC** terminals for fail safe operation.

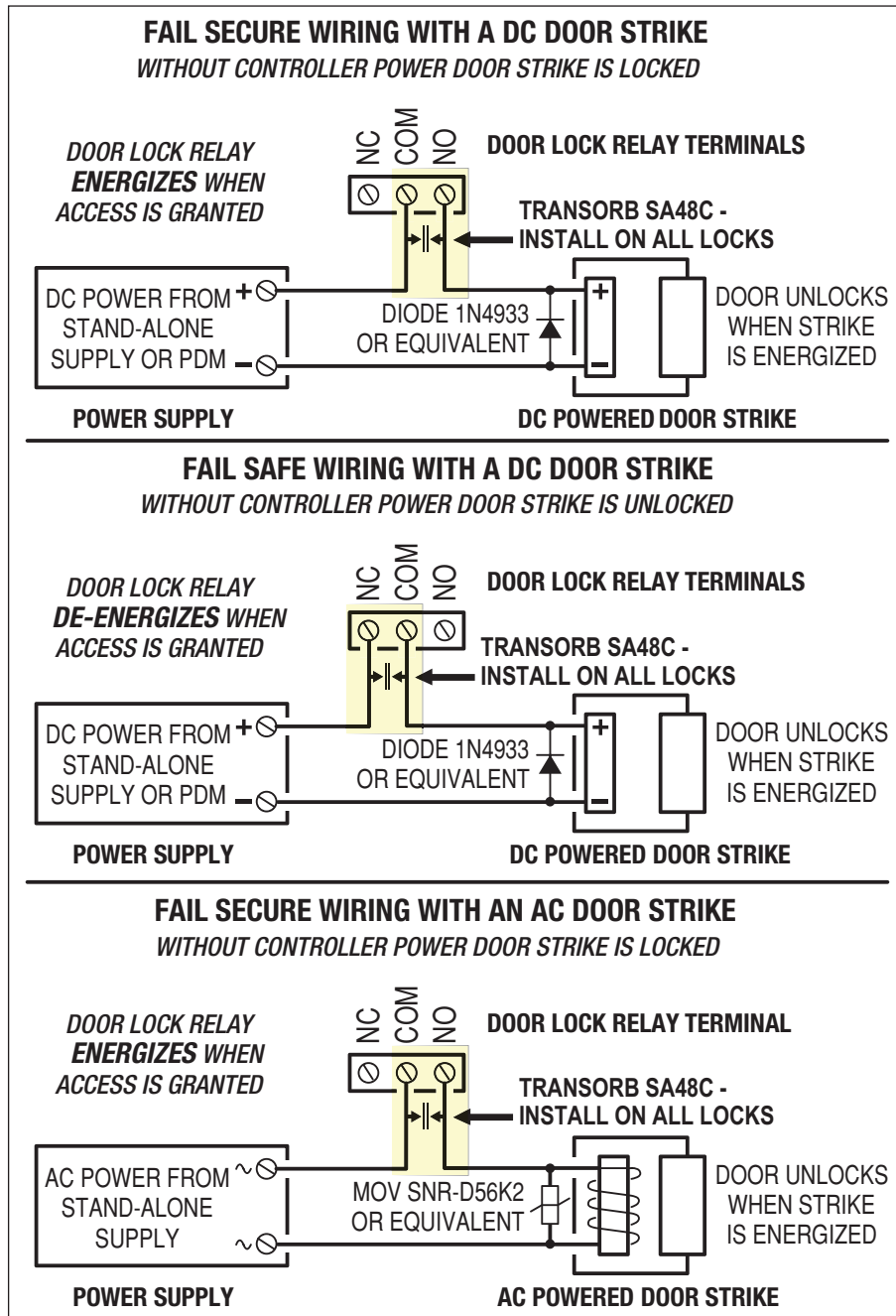

Mag Lock

1. Install a low voltage electric magnetic lock as a locking device for the door or pedestrian gate.
2. Install the power supply or transformer for the locking device. **DO NOT POWER THE UNIT FROM THIS POWER SUPPLY.**
3. Connect one wire from the power supply to one wire from the locking device.
4. Route two wires between the locking device and the unit. Connect one wire to the remaining wire of the locking device. Connect the other wire to the remaining wire of the power supply.
5. Install a protection diode (for DC mag locks or MOV for AC mag locks) across the mag lock to protect the door relay contacts at a point closest to the lock.
6. Connect the wires to the unit's **DOOR LOCK RELAY COM & NC** terminals for fail secure operation or **DOOR LOCK RELAY COM & NO** terminals for fail safe operation.

NOTE: For fail secure operation with a magnetic lock, the lock's power supply must have battery backup to power the lock during a power failure. Be sure to comply with NFPA and local building code requirements.

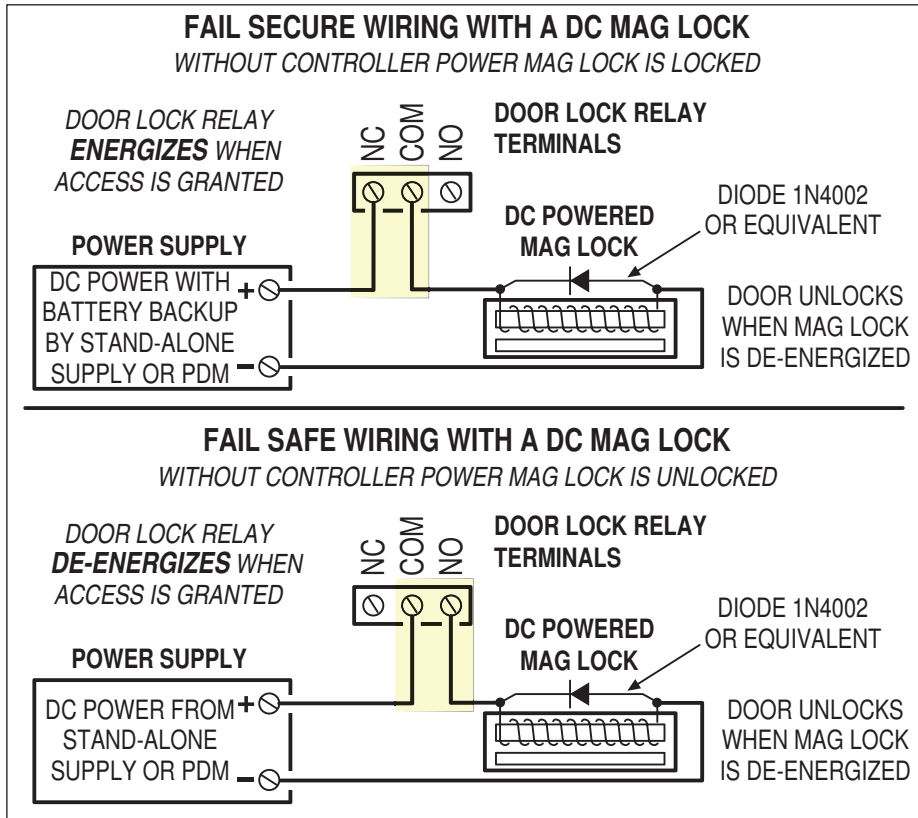

Automatic Gate

The Door Lock Relays can be used to activate an automatic gate operator when a user is granted access.

1. Route two wires between the gate and the unit.
2. Connect the gate operator's **OPEN** terminals to the unit's **DOOR LOCK RELAY COM & NO** terminals.

NOTE: For operator wiring specifics, refer to the gate operator's wiring diagram. See Recommended Wiring Requirements, pg. 12, for proper gauge requirements.

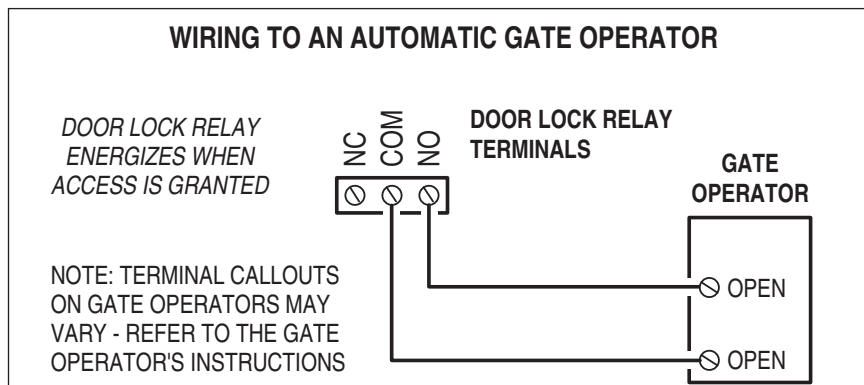

System Input Wiring

Systems have the three types of switch inputs used for monitoring door position (DSM), exit requests (REX), and auxiliary requests.

All inputs are assigned default features that can be configured as needed. The following table shows the default states for each of the inputs:

INPUT	DEFAULT STATE
Door switch monitor (DSM)	Normally open unsupervised Eight (8) second held open time
Request to exit (REX)	Normally open momentary Unsupervised
Auxiliary inputs	Normally open Unsupervised

System Input Wiring

Systems have the three types of switch inputs used for monitoring door position (DSM), exit requests (REX), and auxiliary requests.

All inputs are assigned default features that can be configured as needed. The following table shows the default states for each of the inputs:

Input Options

All inputs may be configured for normally open (factory default) or normally closed contacts with supervision or non-supervision. Use 1k ohm resistors for supervision. Refer to the figure for the acceptable wiring configurations.

Door Switch Monitor (DSM) Inputs

The two DSM inputs for Door Lock Relays A & B can connect to a door switch that monitors whether the controlled door is open or closed. Doors are usually monitored with a magnetic contact or mechanical switch to detect forced entry or door ajar conditions.

1. To use the door switch monitor feature, install a door switch on the door or pedestrian gate and route two wires from the switch to the unit.
2. Connect the sensing device wires to the associated relay sensing terminal **DSM** and **GND** terminals.

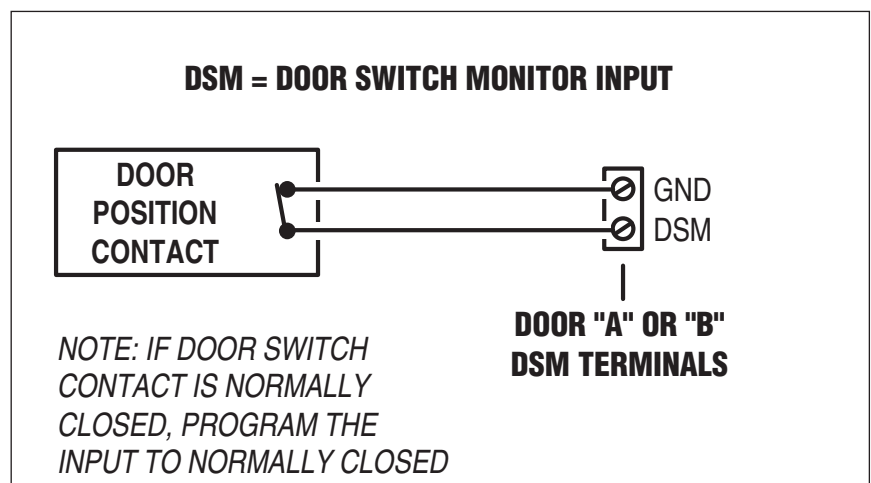
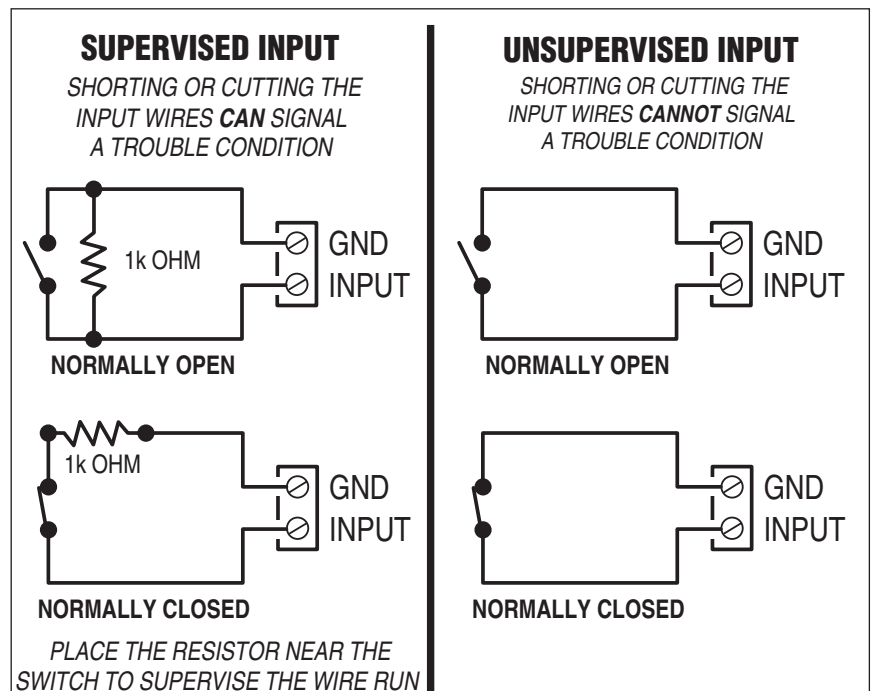

Request-to-Exit (REX) Inputs

The two door relay outputs have REX input terminals. Grounding a REX terminal will request activation for the associated relay. Exit request inputs are typically used with push bars, loop sensors, or pushbuttons.

1. Install the pushbutton or device to signal an exit request.
2. Route two wires from the device to the unit.
3. Connect the device's normally open output to the wires.
4. Connect the two wires to the associated relay's request-to-exit **REX** terminal and **GND** terminal.
5. Connecting the DSM Override allows the administrator portal monitoring without requiring the REX to automatically energize the lock output.

Auxiliary Inputs

The Auxiliary Inputs are general purpose inputs that can be used with a variety of input devices including REX switches, loop sensors, alarm system integration, etc. These inputs can be configured via programming to trigger a defined action such as to activate an auxiliary relay output.

Tamper Protection

A tamper switch is mounted inside the enclosure and connects to terminals on the CPU board. If the cover or enclosure door is opened for any reason the tamper switch will activate, triggering a condition that can be linked to an event action in programming (e.g., send an e-mail or generate an output).

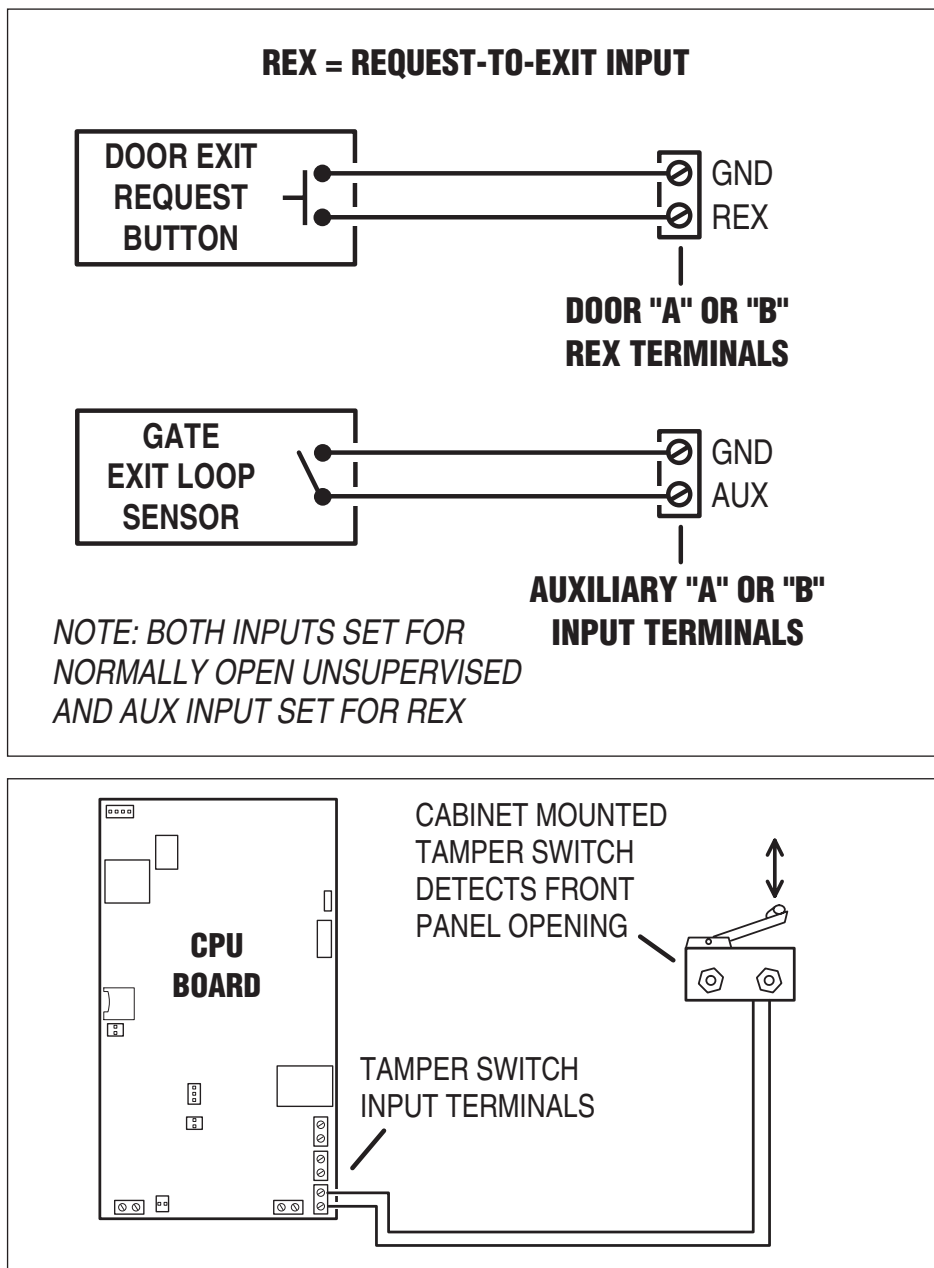

Wiegand Reader

The unit's four Wiegand terminals (WIEGAND #1 IN/OUT & WIEGAND #2 IN/OUT) can be connected to Wiegand readers capable of reading up to 64 bit formats. The Wiegand format is a common standard for access control equipment. A typical application would be to add swipe card or proximity readers to the system. Readers can be installed as primary "in readers" (entry) for each door as well as optional secondary "out readers" (exit).

The maximum power available for an individual reader is 750 mA @ 11-13 VDC with a combined maximum of 1.5A for the unit. Determine the reader's power consumption by referring to the documentation included with the reader. Exceeding the maximum current for individual readers or for the system will damage the protection fuses and void the warranty.

NOTE: Remove Excess Shield. Exposed Shield can cause interference or shorts. Tape off to make sure no shield is exposed.

NOTE: When using Wiegand devices for Reader "B", Reader "B" select jumper must be set to Wiegand position (default).

1. Mount and install the Wiegand accessory as described in its installation instructions.
2. Route the cable from the unit to the accessory.

Recommended cables:

- Belden 9535 (or 24AWG; 5 conductor; Shielded Equivalent)
- Weico 8606/18 (or 18AWG; 6 conductor; Shielded Equivalent)

3. Connect color-coded wires from reader's wiring harness to cable.
4. Connect the cable to the appropriate Wiegand **READER** terminal on the unit (see Wiegand wiring diagram).

IMPORTANT: Reader shields must be properly grounded per the manufacturers installation requirements. See diagram for shield connections.

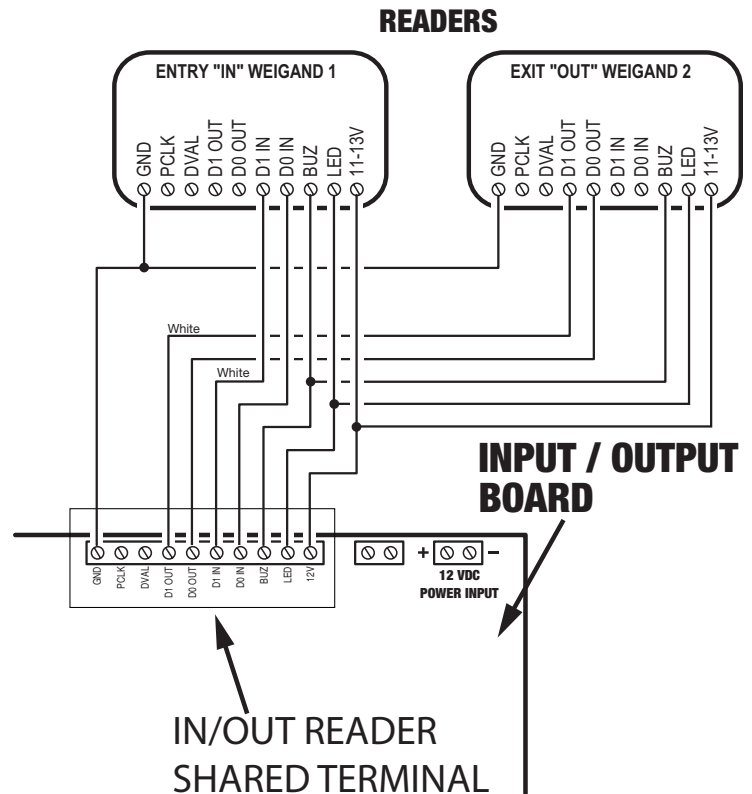

Manufacturers Wiring Recommendation

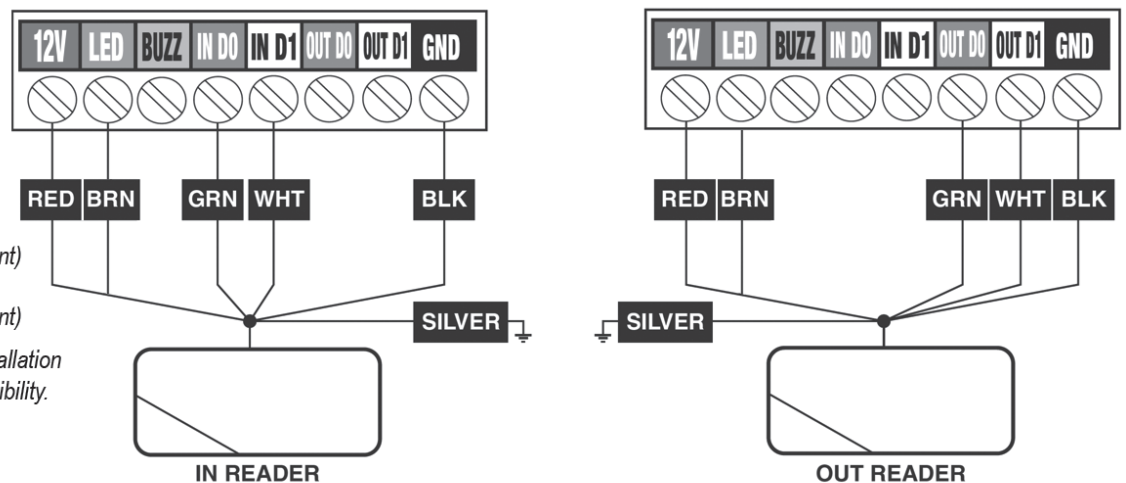

Minimum Cable Specifications:

- Belden 9535 (or 24AWG; 5 conductor; Shielded Equivalent)
- Weico 8606/18 (or 18AWG; 6 conductor; Shielded Equivalent)

Please follow the Reader's installation requirements to ensure compatibility.

Note: Wiring methods shall be in accordance with the National Electrical Code/NPFA 70 and all local codes.

NOTE: A green wire pigtail for earth ground is provided in all enclosures. Reader Shields (SILVER wires) must be properly grounded (to Earth Ground) per manufacturers installation requirements (see **Wiring Diagram**, pg. 7).

Telephone Wiring

For telephone entry applications, the unit connects two wire POTs.

Important Telephone Wiring Tips

- **WIRING SHOULD BE PLACED IN SEPARATE JACKETED CABLES FOR TELEPHONE AND AC.** Route all telephone wires inside a dedicated conduit that is at least six inches away from any AC line wiring.
- All telephone wiring must be made on the “building” side of the telephone company’s demarcation device (the terminal block where the telephone line connects to the building).
- If any security system or personal alert system at the installation is connected to the telephone line, be sure that it is connected to the line ahead of the unit using a RJ-31X or RJ-38X interface.
- Use only high-quality telephone wire. All telephone wire should be twisted-pair with a minimum size of 24 AWG.

Typical Telephone Wiring

1. Connect a double-ended modular RJ-11 cable to the unit’s **TELEPHONE** jack.
2. Connect the RJ-11 modular cable to the telephone jack wired to the installation’s telephone line.

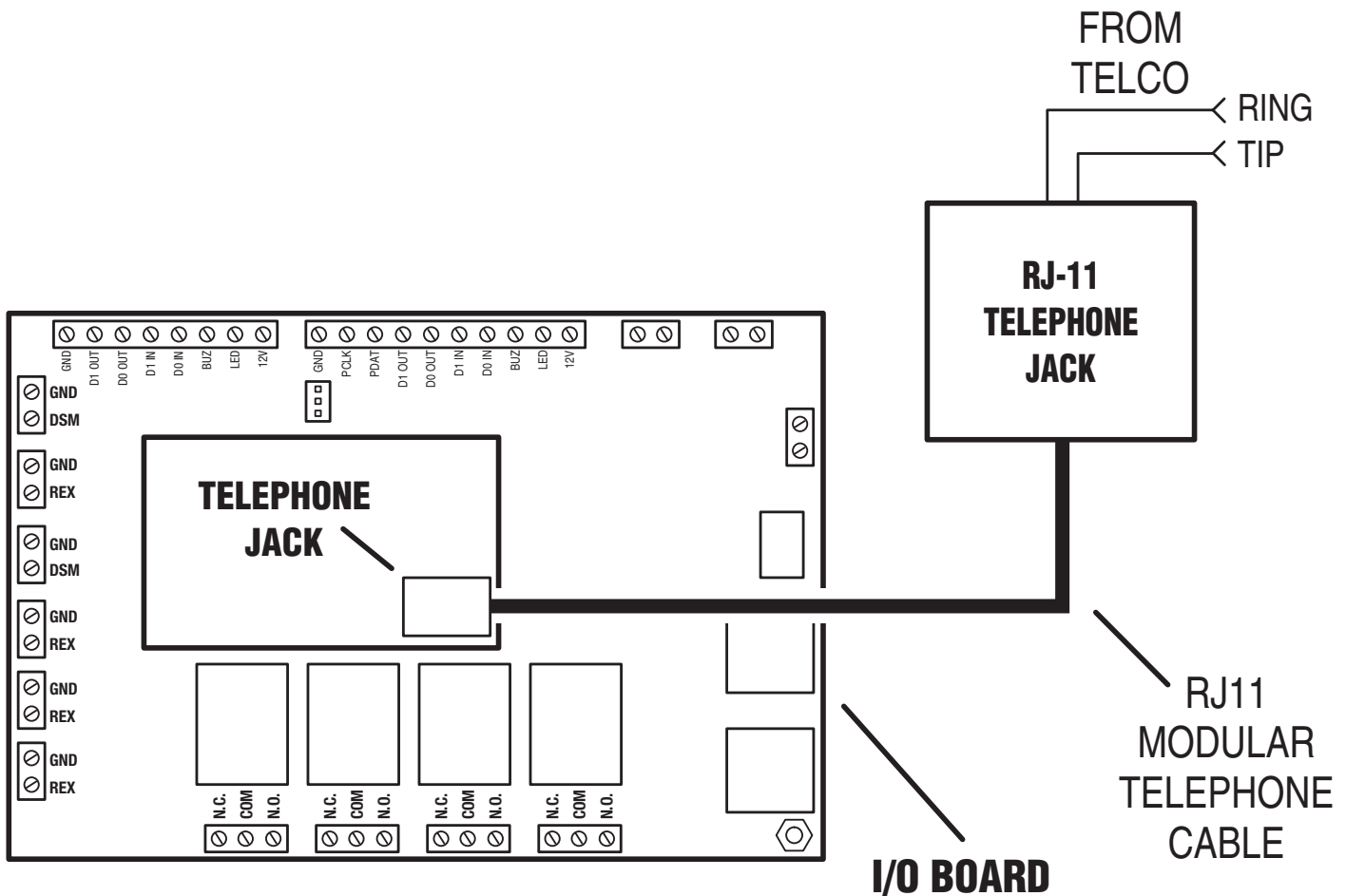

Operational Postal Lock

A postal lock can be installed in the EP Series unit to provide keyed access for the postal service. The unit's case is designed to accept a U.S. Postal Service postal lock. When the postal lock is engaged, the programmed output relay will activate.

Postal Lock Installation

1. Cut and discard the tie-wrap that is holding the postal lock switch engaged.
2. Remove the four screws that retain the postal lock cover plate.
3. Remove the postal lock cover plate. The postal lock cover plate will not be used and can be discarded.
4. Install the postal lock assembly onto the four studs. The postal lock's moving plunger should point towards the middle of the faceplate, towards the postal lock switch (see figure).
5. Secure the postal lock with the four screws.

NOTE: Be sure the postal lock's plunger actuates the microswitch. Adjust the postal lock then test the action until the microswitch fully actuates.

6. Tighten the four screws after the adjustment and testing is complete.
7. When programming the system, set the postal lock option to activate the desired relay output.

① REMOVE SCREWS, SPACERS, AND WASHERS

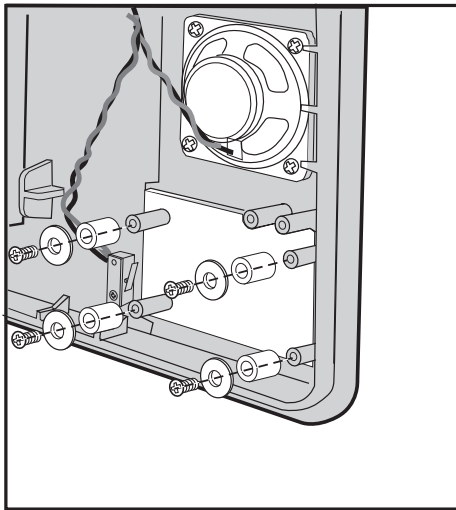

② REMOVE AND DISCARD PLATE AND SPACERS

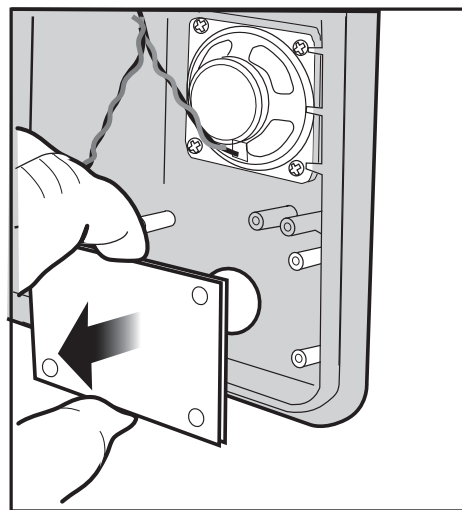

③ INSTALL POSTAL LOCK

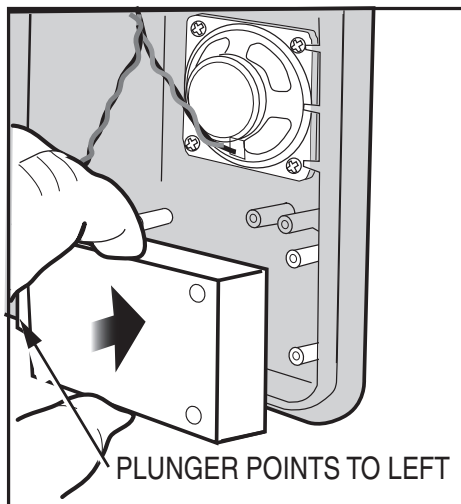

④ REINSTALL 4 SCREWS AND WASHERS TO SECURE POSTAL LOCK IN PLACE

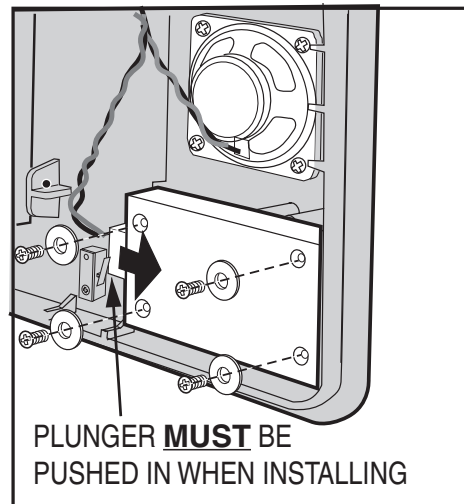

Optional Internal Card

A card reader can be installed inside the EP Series unit. Using a built-in card reader saves the time and expense of installing a stand-alone card reader next to the controlled access point. The user presents their credential directly to the unit's front panel.

The unit is designed to accept mounting of a card reader. The card reader is retained by brackets inside of the unit's front panel. Check the Web site www.nortekcontrol.com for compatible card reader models.

The built-in card reader is a Wiegand device and connects to either of the unit's reader connectors.

Card Reader Installation

1. Remove the four screws that hold the two card reader retaining brackets.
2. Align the card reader to the card reader retaining area on the inside of the front panel of the unit with the reading surface towards the front of the system.
3. Position each of the card reader retaining brackets behind the reader and attach the brackets with the four mounting screws.
4. Connect the card reader wires to one of the available reader terminals on the unit.

- ① Loosen screws to remove Retaining brackets.

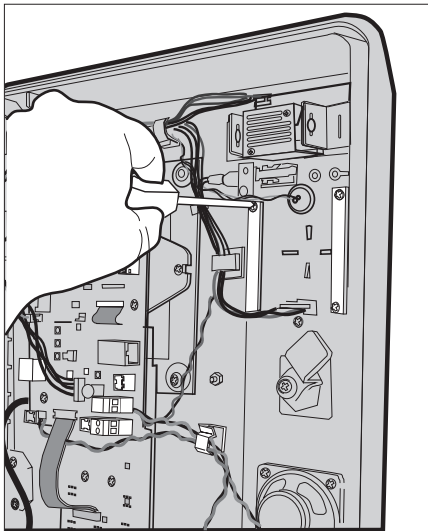

- ② Align the Reader in the front panel

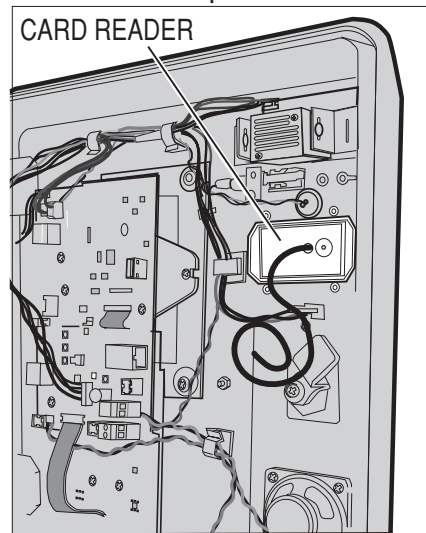

- ③ Reinstall retaining brackets.

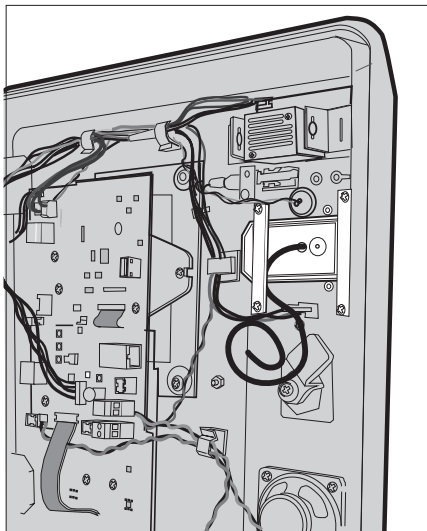

- ④ Connect the Reader to the terminal. Be certain to place the cable through the wire wrap / tie downs.

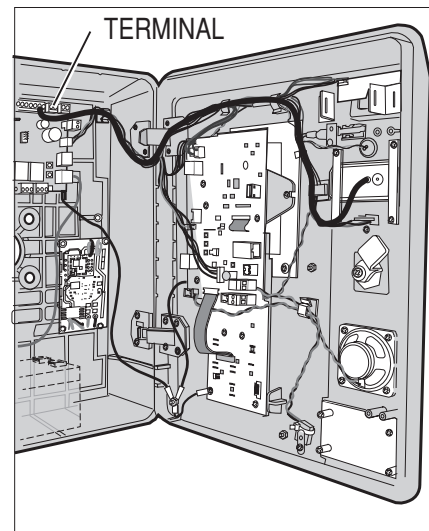

STEP 1: Power & Ground Wiring

The unit requires power from a 11-13 volt DC power source.

WARNING: Do not connect to an AC receptacle controlled by a switch.

NOTE: If the unit is powered directly from the plug-in power supply, a separate power supply **MUST** be used for door locks and accessories. Recommended is the Power Distribution Module (PDM) (optional-not included). The PDM will notify the system if an AC power failure occurs.

Power Options

- Power the unit directly from the 12 VDC 24 W plug-in power supply.

Power Wiring

NOTE: DO NOT APPLY POWER UNTIL THE INSTALLATION IS COMPLETE.

1. Route three-conductor cable between the unit and the 0-291312RU plug-in power supply. To indicate DC polarity, be sure to use cable with multiple wire colors.
 - For power wire runs up to 100 feet, use 16 AWG, THHN 600-volt insulated wire.
 - For power wire runs up to 200 feet, use 14 AWG, THHN 600-volt insulated wire.
2. Connect two wires to the plug-in power supply's + & - terminals.
3. Connect one wire to the plug-in power supply's **EARTH GROUND** terminals.
4. Connect the + & - from the plug-in power supply to the system:
 - Connect the + & - power wires from the plug-in power supply to + & - **12 VDC POWER INPUT** terminals on the **I/O Board**.
5. Connect the **EARTH GROUND** wire from the plug-in power supply to the unit cabinet door **EARTH GROUND** stud.
6. When the installation is complete, plug the power supply into a dedicated indoor AC receptacle that is not controlled by a switch.

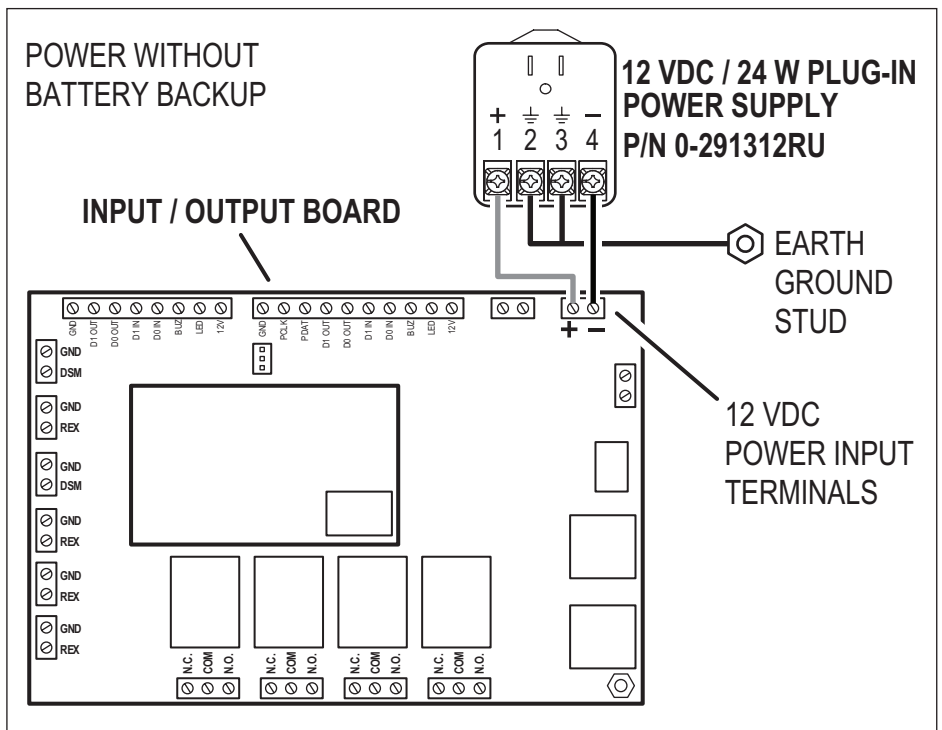

NOTE: The gauge wire should always be thicker than the others, because it carries all system power.

Earth Grounding Option

For an NEC compliant earth ground, use size 12 gauge solid wire or larger and clamp it to an 8-foot copper ground rod driven into the ground. Locate the ground rod next to the Intersystem Bonding Termination point (Power and Telephone company ground rods) and bond the rods together with a 6 AWG or larger bonding jumper. **Do not disturb the clamps installed by the Power or Telephone Company.**

1. Install the ground rod as described above.
2. Connect the wire from the earth ground to the unit's cabinet door **EARTH GROUND** stud.

EP Series units are grounded to help prevent against electrical sparking, fire, and/or electrical shock. It is recommended to maintain the grounding securely at all times.

WARNING: The Earth Ground Stud and Rod are safety features designed to prevent sparking, fire, and/or electrical shock. Do not attempt to bypass this safety feature. Harm to personnel and equipment may result.

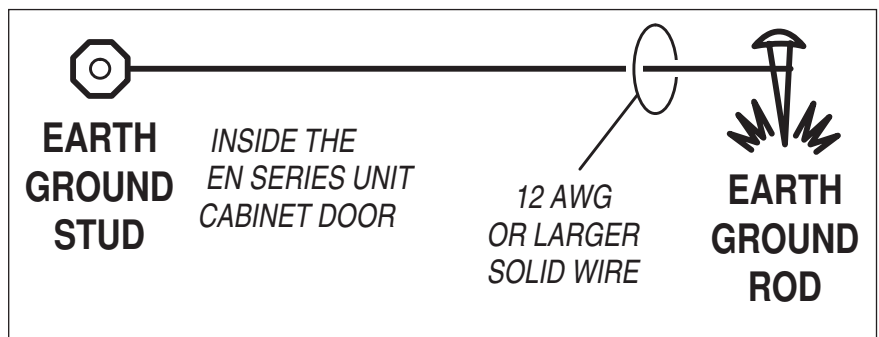

STEP 2: IP Address Configuration

WARNING: Do Not connect an Ethernet cable from the EP-xxx CPU to the Local Area Network (LAN) before the Initial IP System Configuration has been completed.

The E3 Entry Pro and Access Control system can be a standalone system or part of a larger Access Control network. Regardless of the type of installation the initial IP configuration of the EP is done between a Laptop/PC and the EP unit directly connected to each other not part of the local network.

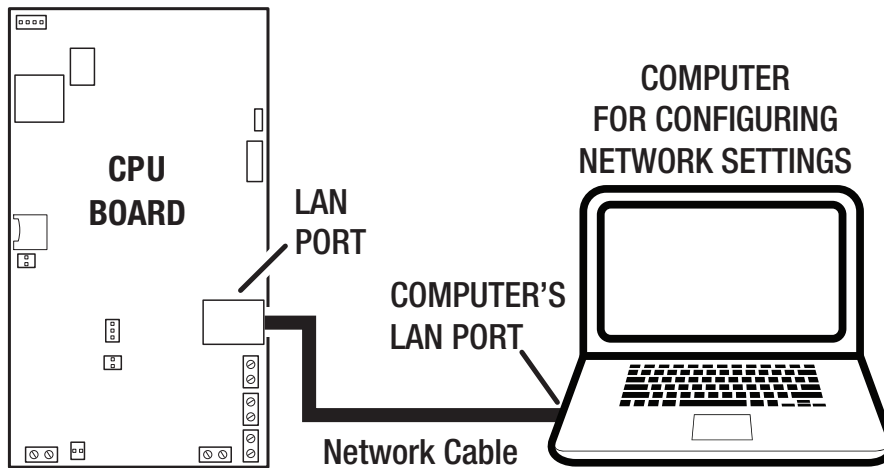

NOTE: A Telephone Entry or Access Control Systems should always have a static IP Address assigned to them not a DHCP dynamically assigned address.

Consult the appropriate on-site IT administrator to obtain the following information before configuring the EP system:

- IP address: _____
- Subnet Mask: _____
- Gateway: _____
- DNS 1: _____
- DNS 2: _____

Configure IP Network Settings

To allow for the system to be recognized on the local network, it is necessary to change the unit's default IP address as follows:

1. Connect your programming computer directly to the LAN port of the EP-xxx unit. A standard CAT5 or better networking cable is used for the direct connection.
2. Assign a static IP address of 192.168.0.149 to the computer. (For instructions on how to change the static IP address of a Windows computer, please visit: <http://technet.microsoft.com/en-us/library/ff710457>)
3. After assigning the static IP address to the computer, open a web browser and enter the default IP address of the unit (Default = 192.168.0.250).
4. The unit presents the login page.

To log on, enter the default user ID and Password:

User ID: admin

Password: admin

NOTE: It is highly recommended to change the default Password.

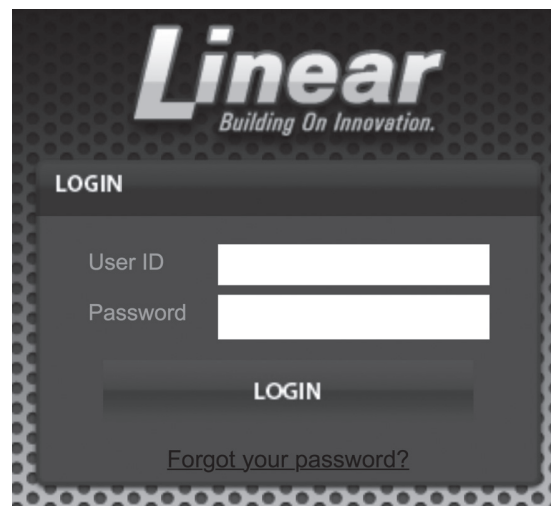

5. Select the Network Setting icon, then the IP Address icon to display the IP settings page.

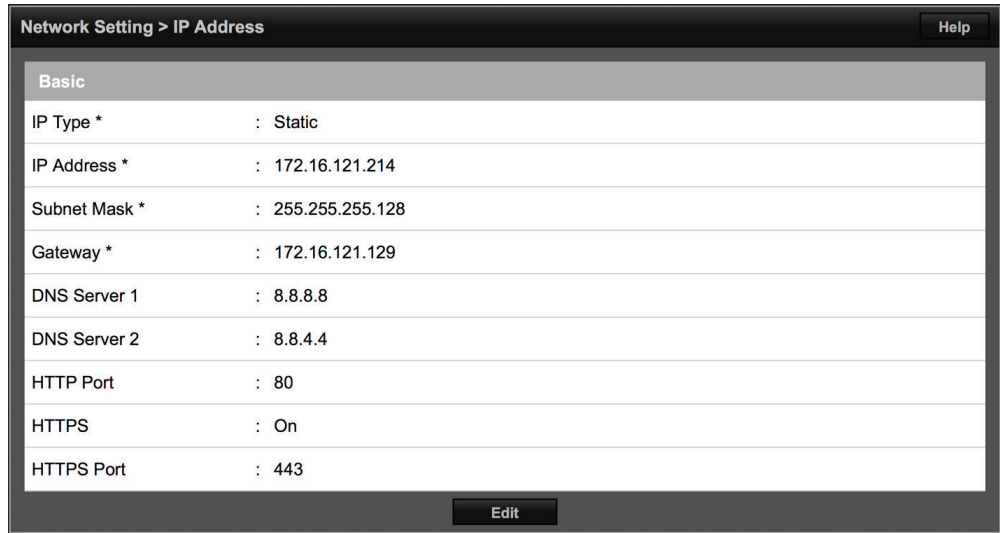
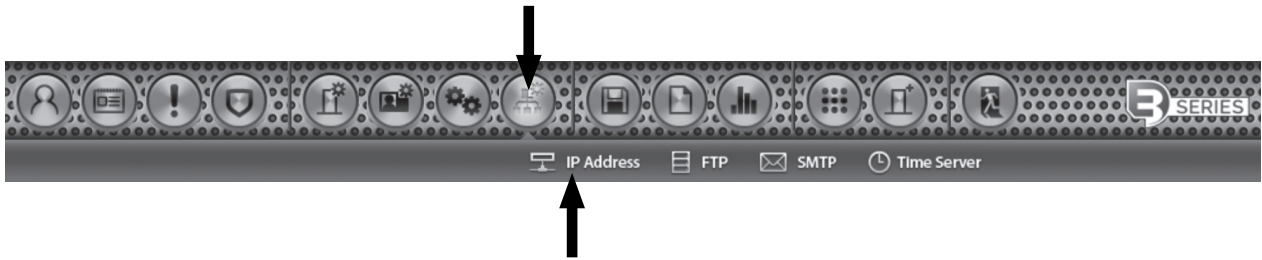

Enter the static IP address, Subnet Mask, Gateway and DNS server so that it matches the requirements of the local network provided by the IT administrator.

6. Click **Save & Reboot** for the settings to save and take effect. (The reboot will take approximately 2 minutes.)

NOTE: The IP settings will be lost if the unit is powered down without performing Save & Reboot.

7. Disconnect the programming computer from the unit. The system is now ready for connection to the local network.

CAUTION: The EP is an Access Control system and should be on an isolated or segmented Security network where a protected network security appliance (firewall, etc.) is installed and maintained. This will help prevent unwanted access from the shared company network environment.

NOTE: Port forwarding should not be utilized to provide remote Internet access. If remote access from the Internet is required a VPN should be used to ensure the security of the system.

8. Connect the networking cable from the Local Area Network to the unit's LAN port. The local computers will then be able to access the system by entering the new static IP address of the unit.

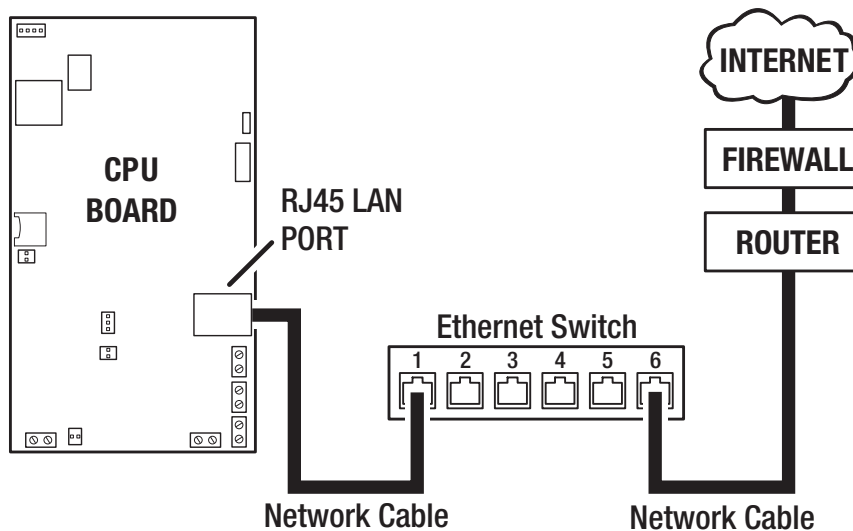

Multi-Unit Installation - Telephone Entry

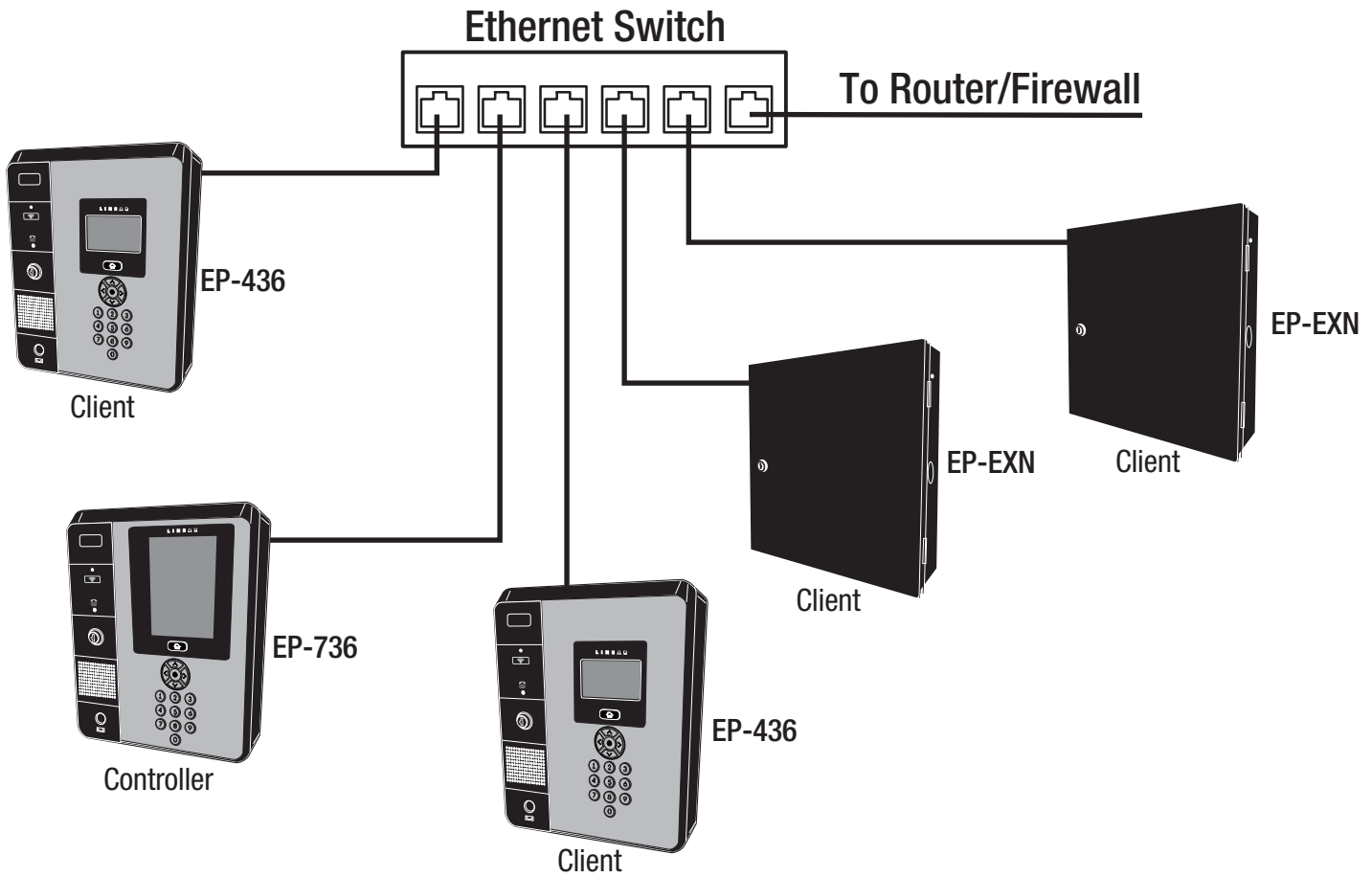

NOTE: In a multi-unit installation, only one EP unit should be the Controller all others should be clients. Use the License-To-Go procedure to configure the clients units. EP-EXN units come preconfigured as clients.

CPU Board Indicators

There are four LED indicators on the CPU Board. Refer to the figure for the location of each indicator.

- **CPU BOARD POWER** lights when power to the CPU board is on.
- **BOOT** lights during an external I/O board boot sequence.
- **RESET** lights an external I/O board reset.
- **I/O BUS POWER** lights when power on the I/O bus is on.

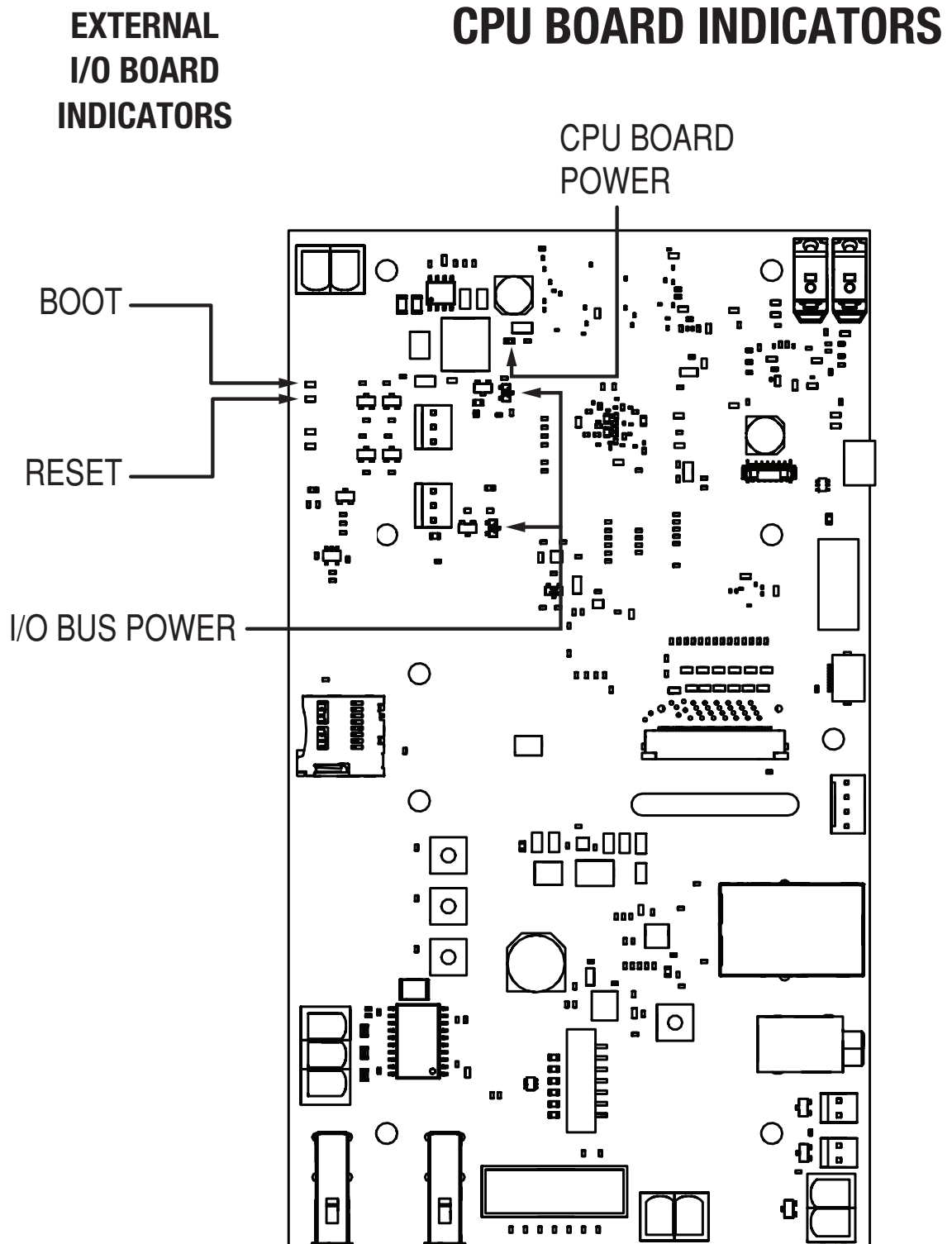

Internal Controls

I/O board Pushbuttons

Six pushbuttons are on the I/O Board. Refer to the figure for the location of each pushbutton. The LOCK / AUX relays can activate Construction Mode, which allows for manual control of doors and gates to keep them open during heavy construction or other high level traffic.

- DOOR "A" LOCK RELAY button manually activates the Door "A" Lock Relay.
- DOOR "A" AUX RELAY button manually activates the Door "A" Auxiliary Relay.
- DOOR "B" LOCK RELAY button manually activates the Door "B" Lock Relay.
- DOOR "B" AUX RELAY button manually activates the Door "B" Auxiliary Relay.
- **SYSTEM BOOT** button reboots the entire system.
- **SYSTEM RESET** button resets the entire system.

CPU board Pushbuttons

Four pushbuttons are on the CPU Board. Refer to the figure for the location of each pushbutton.

- **FACTORY RESET** button resets the system to the factory defaults. **PRESSING FACTORY RESET WILL DELETE ALL PROGRAMMING AND CARDHOLDER INFORMATION.**
- **NETWORK RESET** button resets and restarts the system network.
- **ADMIN RESET** button resets the unit's admin code.
- **CPU RESET** button resets and restarts the system CPU.

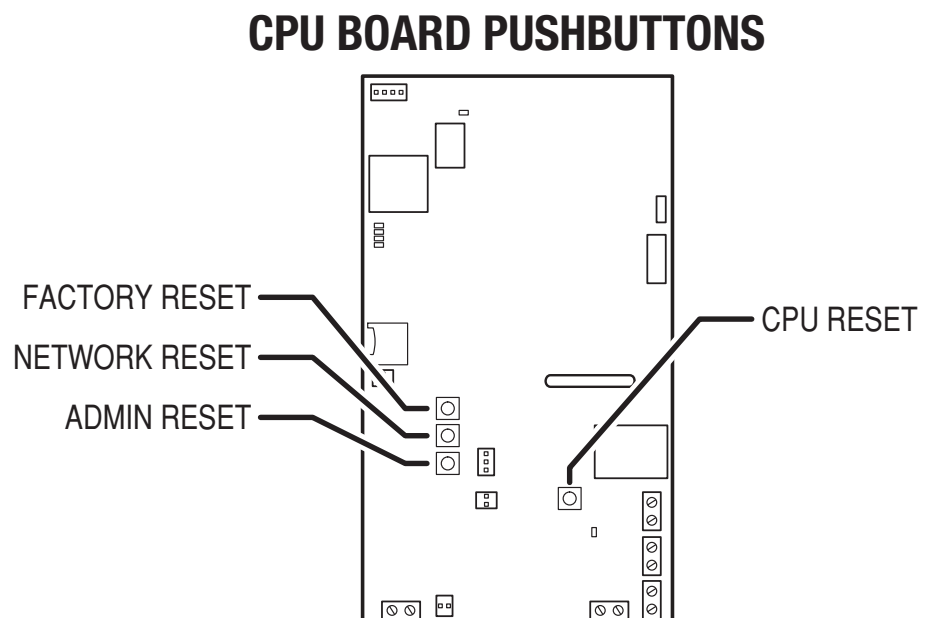
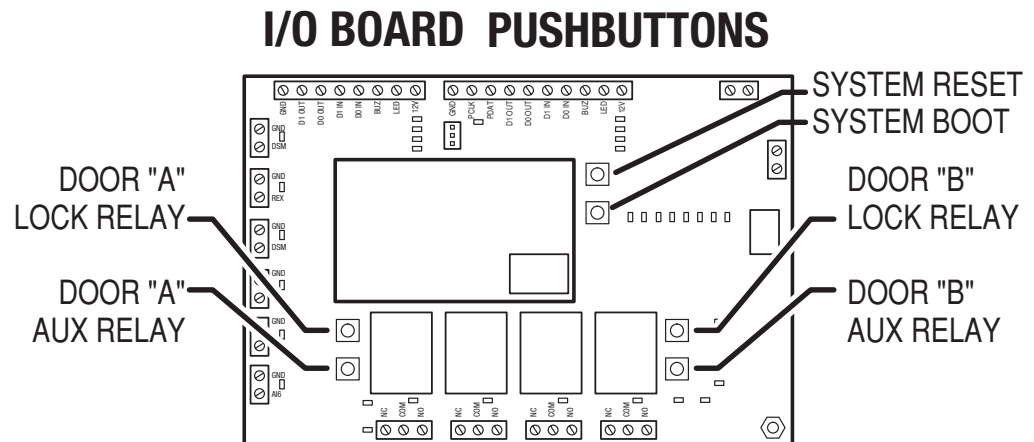

Dimensional Drawing – EP - 4xx

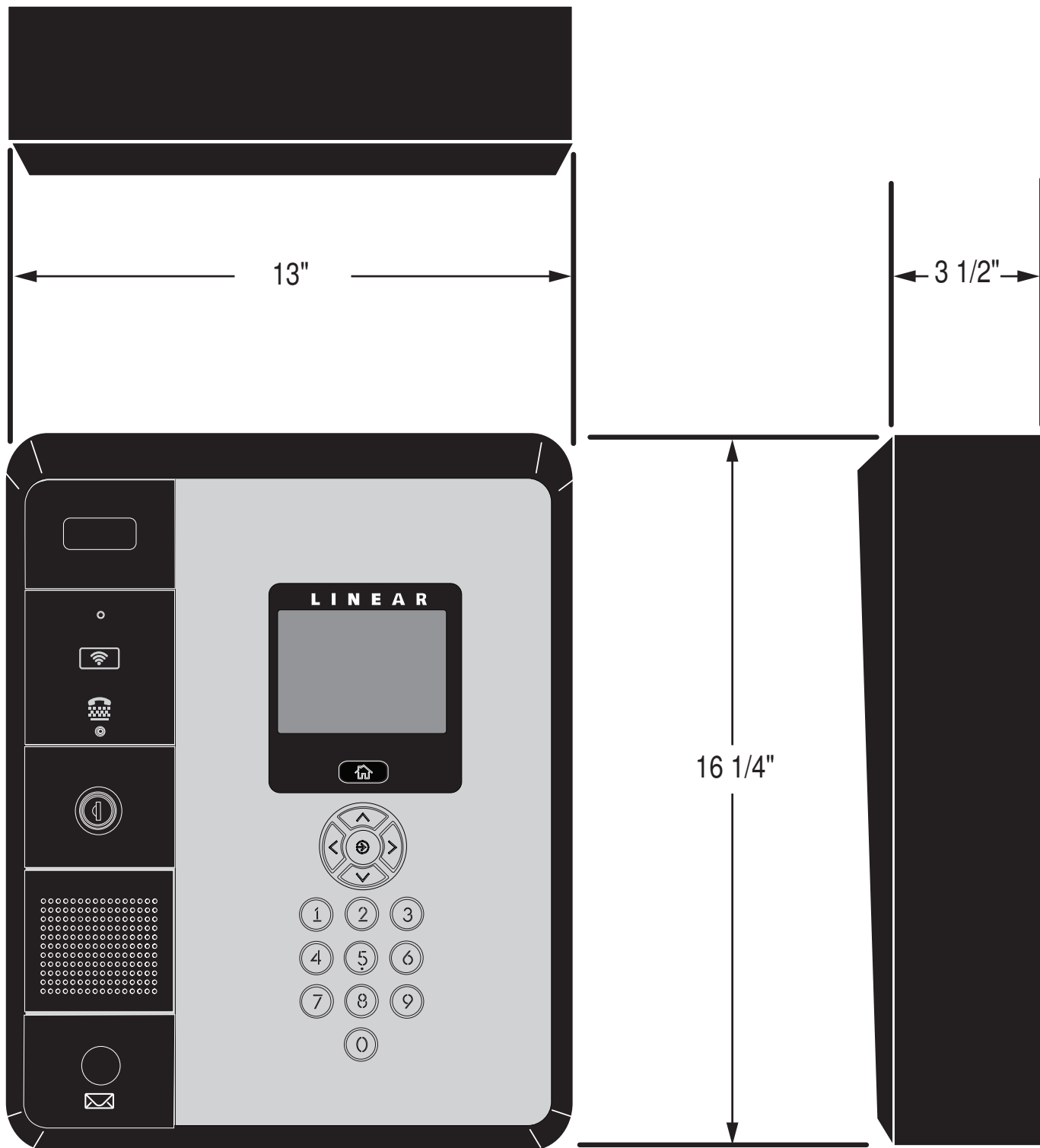

Dimensional Drawing – EP - 7xx

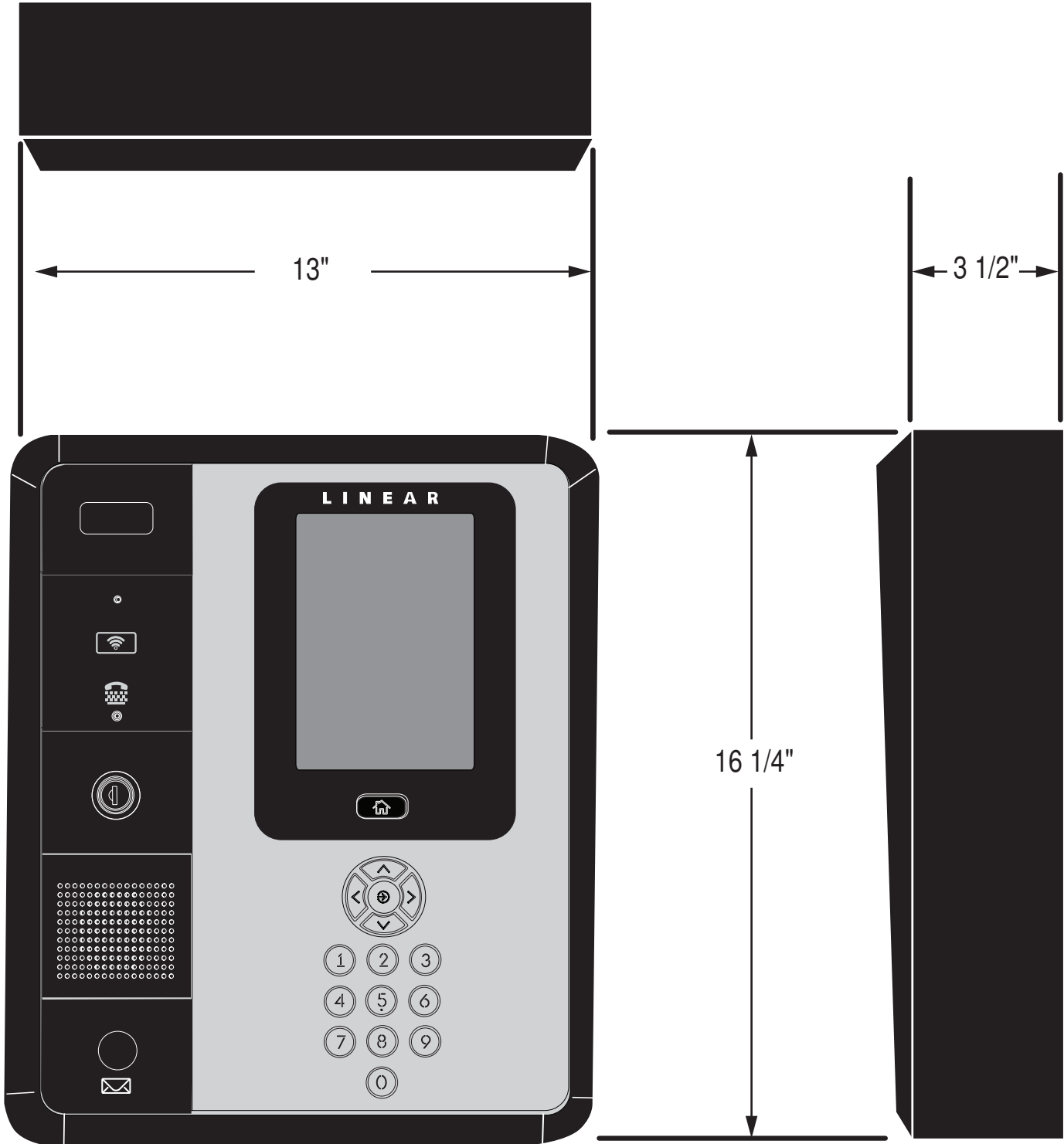

Troubleshooting

System completely dead

- No power from power supply. Check voltage at power supply terminals.
- Check voltage at I/O Board power terminals.

Buzz on speaker

- Check for telephone line shorted to ground.
- Verify that telephone wires are twisted pair.
- Verify that the EN-4xx is connected to earth ground.

Buzz on telephone line

- Check all connections for any shorts to ground.

System will not answer an incoming call

- Automatic telephone answer disabled.
- EN-4xx telephone line trouble.

Entry code will not activate relay

- Entry code not assigned.
- Entry code not set up for proper relay.
- Keypad is in lockout.
- Review diagnostic LEDs.

Remote Wiegand device does not work

- Check remote device for power.
- Assure device is wired correctly.
- Check the position of the Reader #1 select jumper.
- Move to second port and see if unit works.

Main or remote keypad will not activate a relay

- Entry code is not assigned.
- Keypad may be in lockout from too many incorrect attempts. Wait one minute for lockout to clear and try again.
- Remote keypad wiring incorrect.

Resident's Telephone does not ring when a visitor calls

- Resident's telephone number programmed incorrectly.
- Check the telephone line.
- Call resident from another line or cell phone to determine if the resident's telephone is working.

Transmitter does not activate relay

- Transmitter button setting programmed to "no relay" (would effect all transmitters).
- Transmitter not enrolled.
- Specific transmitter is deactivated in the system.
- See receiver LEDs for transmission reception.

Data lost from programming prior to field installation

- Manual backup must be performed via the Save and Reboot tab (on user portal interface) to save data.
- Without battery backup, if the system is powered down prior to saving, data will be lost.
- The EP series performs an automatic backup every 1.5 hours and/or upon A/C loss when on battery to permanent memory.

Specifications

MECHANICAL

Case dimensions: 13" W x 16-1/4" H x 3-1/2" D

ELECTRICAL

Voltage: 11V-13V Volts DC

Current: 750 mA

Outputs: Four Relays (2 Portal, 2 Aux)
Form "C" 5 Amps @ 24 Volts maximum

Inputs: Two DSM door position inputs
Two REX exit request inputs
Two AUX auxiliary inputs
Four WIEGAND reader inputs (two IN, two OUT)

Network: LAN

ENVIRONMENTAL

Temperature: -22°F to 149°F (-30°C to 65°C)

Humidity: 5% to 95% non-condensing

The MECHANICAL, ELECTRICAL, and ENVIRONMENTAL specifications are inclusive of all EP Series models including EN-4xx, EN-7xx and UL294.

Case dimensions are uniform through all the variants and do not change the overall foot print of the device.

Feature Levels

Destructive Attack	Level II
Ethernet Line Security	Level II
POTS Line Security	Level I
Endurance	Level IV
Standby Power	Level I

Unit Operation

Requesting Access with an Entry Code

- Residents have up to 40 seconds to key in their entry code.
- Up to eight seconds are allowed between each keystroke.
- All digits of the entry code must be entered. Example: If the entry code length is set for four digits, and the code is 0042, the user must enter "0 0 4 2".
- If the wrong key is pressed, pressing the  key will reset the keypad. The correct code can then be entered.
- After a correct code is entered, and if the conditions for granting access are fulfilled, the programmed relay will activate for the programmed time.
- If the number of incorrect codes entered exceeds the keypad lockout count, the keypad will be locked and not accept any entries for one minute.
- If the Anti-passback feature is enabled, the entry code will be unusable until the anti-passback time expires.

Requesting Access with a Wireless Transmitter

- Activate a wireless transmitter within radio range of the unit's antenna. Each transmitter must be entered into the system as a credential and associated to a user.
- After a valid transmitter is decoded, and if the conditions for granting access are fulfilled, the programmed relay channel will activate for the programmed time.
- If the Anti-passback feature is enabled, the transmitter will be unusable until the anti-passback time expires.

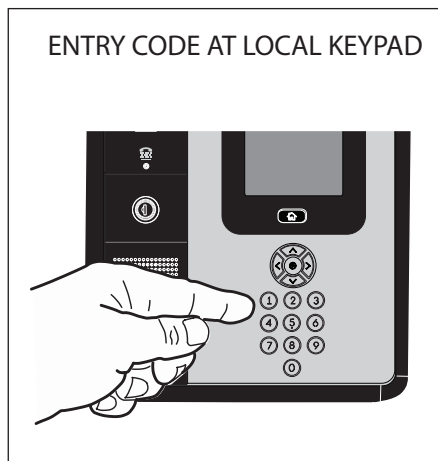

Refer to the **Front Panel Programming Guide** for more specific settings and configurations.

Requesting Access with a Visitor Call

- Navigate to Resident Directory using Navigation keys.
- Scroll through the alphabet to the first letter of the last name.
- Press Enter.
- Scroll through name list to desired entry.
- Press Enter to call.
- If the visitor already knows the resident's directory number, they can enter the directory number to call the resident.
- The system dials the resident's telephone number to establish 2-way communications.

NOTE: The resident's telephone number will never be displayed to the visitor.

- If the resident is using the telephone at the same time a visitor calls, the display will indicate to the visitor that the line is busy.
- The resident answers the call and converses with the visitor to determine if access will be granted.
- The resident can use their telephone's keypad to grant access activating Relay Channel "A" by pressing **9**. After access is granted, the system will disconnect the visitor and resident call.
- The resident can disconnect the visitor without granting access by pressing ***** or by hanging up.

NOTE: The telephone keys that the resident presses can be customized for the installation.

- The length of time the visitor is allowed to talk can be programmed from 30-300 seconds.

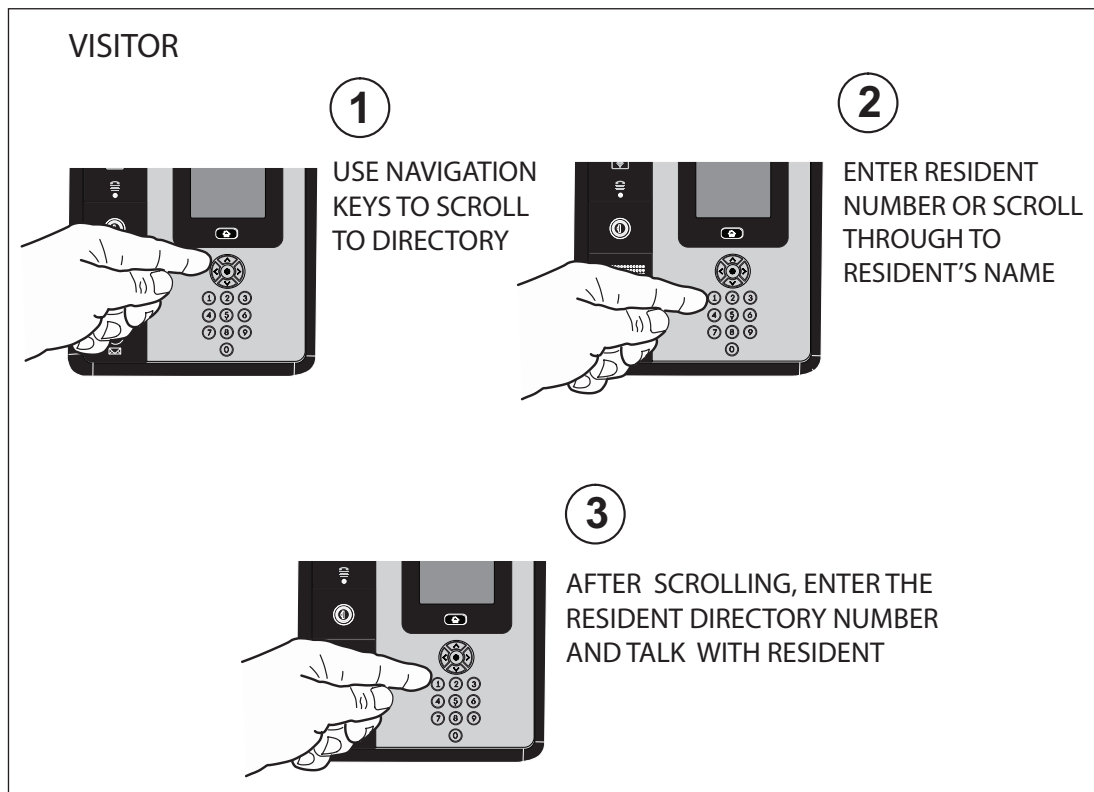

Test and Maintenance Operations

Prior to installation, ensure that all inside wiring is secure. Each unit should be checked annually for any loose wire connections.

Impaired Operation

Units are designed to operate under adverse environmental conditions. Under normal circumstances, they will function properly regardless of outside conditions. However, units do not have secondary power sources and cannot function without direct continuous power. If a unit is damaged by natural causes or deliberate vandalism, it may not function properly depending on the level of damage.

Limited Warranty

This Nortek Security & Control LLC product is warranted against defects in material and workmanship for twenty-four (24) months. **This warranty extends only to wholesale customers** who buy direct from Nortek or through Nortek's normal distribution channels. **Nortek Security & Control LLC does not warrant this product to consumers.** Consumers should inquire from their selling dealer as to the nature of the dealer's warranty, if any. There are no obligations or liabilities on the part of Nortek Security & Control LLC for consequential damages arising out of or in connection with use or performance of this product or other indirect damages with respect to loss of property, revenue, or profit, or cost of removal, installation, or reinstallation. All implied warranties, including implied warranties for merchantability and implied warranties for fitness, are valid only until the warranty expires. This Nortek Security & Control LLC Warranty is in lieu of all other warranties express or implied.

All products returned for warranty service require a Return Authorization Number (RA#). Contact Nortek Security & Control Returns at 1-855-546-3351 for an RA# and other important details.

FCC Notice

Changes or modifications not expressly described in this manual or approved by the manufacturer could void the user's authority to operate the equipment.

This equipment has been tested and found to comply with the limits for a Class B digital device, pursuant to Part 15 of the FCC Rules. These limits are designed to provide reasonable protection against harmful interference in a residential installation. This equipment generates, uses and can radiate radio frequency energy and, if not installed and used in accordance with the instructions, may cause harmful interference to radio communications. However, there is no guarantee that interference will not occur in a particular installation. If this equipment does cause harmful interference to radio or television reception, which can be determined by turning the equipment off and on, the user is encouraged to try to correct the interference by one or more of the following measures:

- Reorient or relocate the receiving antenna.
- Increase the separation between the equipment and receiver.
- Connect the equipment into an outlet on a circuit different from that to which the receiver is connected.
- Consult the dealer or an experienced radio/TV technician for help

LINEAR

Technical Support: (800) 421-1587 • M – F 8am – 7pm EST

Sales & Customer Service: (800) 543-4283, M – F 8am – 7pm EST • **Website:** www.linear-solutions.com



5919 Sea Otter Place, Suite 100, Carlsbad, CA 92010 USA

©2021 Nortek Security & Control LLC. Linear and GTD are trademarks of Nortek Security & Control LLC. All rights reserved.

Page left intentionally blank