

Specifications and Wiring for 1300F or 1300S

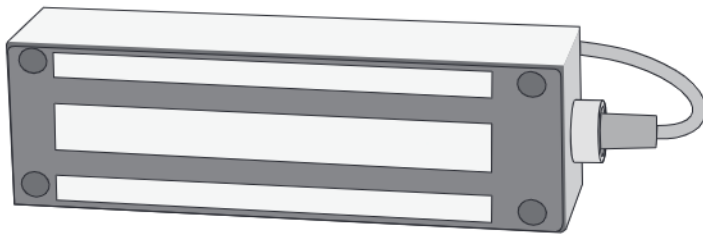

Model # EMLO 1300F
Face Mount

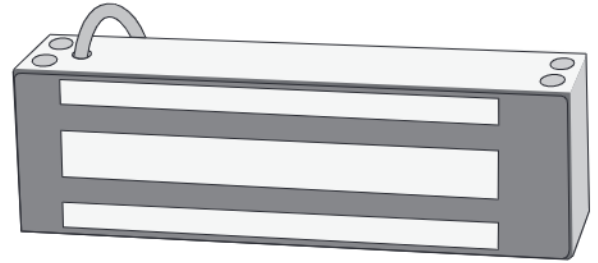

Model # EMLO 1300S
Surface Mount

Specifications:

Housing: Stainless Steel

Plating: Zinc

Power Supply:

12 VDC Supply:

Transformer: input .20 VAC, output: 7.2 VA 12 VDC @ 500mA

24 VDC Supply:

Transformer: input .20 VAC, output: 14.4 VA 24 VDC @ 600mA

Current draw: 250 mA @ 24 V 500 mA @ 12 V 300mA

If power supply is 12 VDC and wire is 50 ft use 18 AWG, if wire is 150 ft use 14 AWG.

If power supply is 24 VDC and wire is 50 ft use 22 AWG, if wire is 150 ft use 18 AWG.

**Do Not Use Wire
Smaller than
22 AWG**

Handling Maglock:

The electromagnetic lock and armature are ruggedly constructed and designed to provide years of trouble free service. Care must be taken during installation and during actual use so that the lock face and the armature face are free of dirt, rust, burrs, paint or any other obstruction which may interfere with the lock and armature making good contact.

Mounting Maglock:

The lock must mount rigidly to the gate/door frame, and the armature must mount to the gate/door. (See reverse side).

Wiring 12 VDC or 24 VDC Transformer (Not Included)

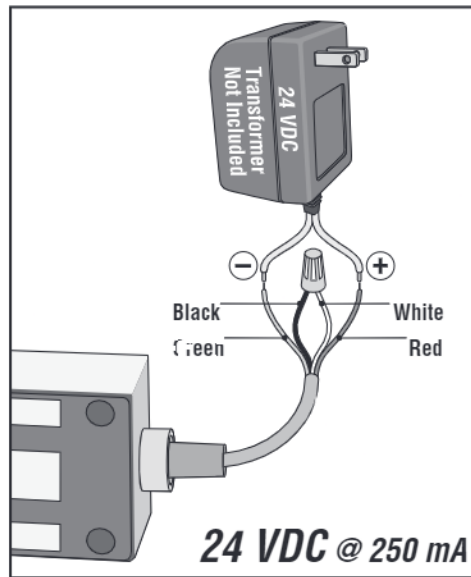
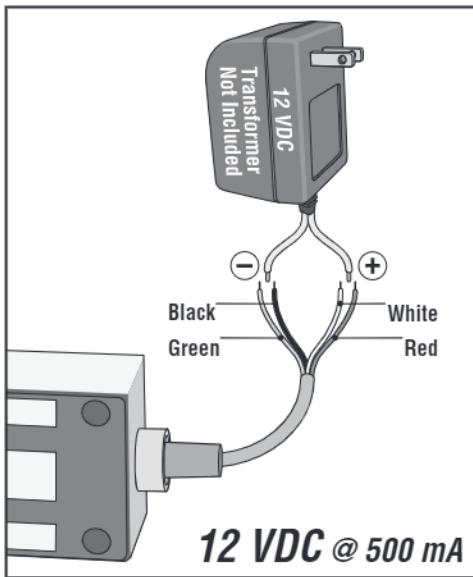

Maintenance of Maglock:

To insure peak lock performance, clean the lock and armature faces with a mild detergent and a clean soft cloth. Then apply a light coat of rust inhibitor, such as WD40, to lubricate and protect these surfaces. This need only be done when dirt build-up is noticed.



**Surface Mount
Model # EMLO 1300S**

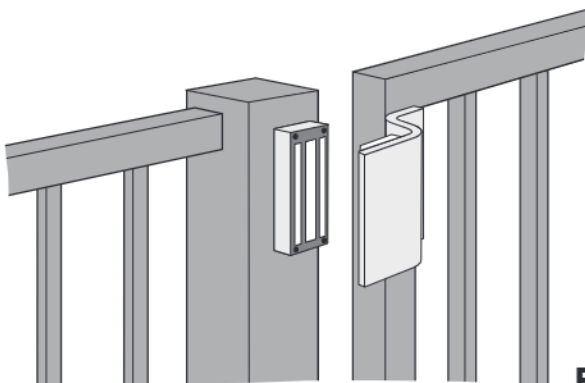

Face Mount Model # EMLO 1300F



Mounting the Magnetic Lock and Armature

STEP 1: Determine position of Magnetic lock and Armature on gate/door and header/post. Use the template provided for the Model to be installed. Transfer the position of the hole locations for both the Magnetic Lock and Armature.

CAUTION!
Be *precise* when marking hole with template.

STEP 2: Mount Armature in accordance to Gate or Door type. (See illustrations below) Install anti-spin guide pins in the back of the armature as shown to the right, this insures the plate will not move after installation.

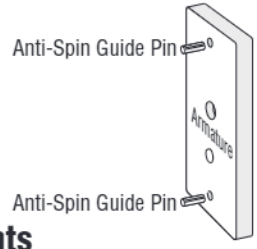

Types of Door/Gate Armature Attachments

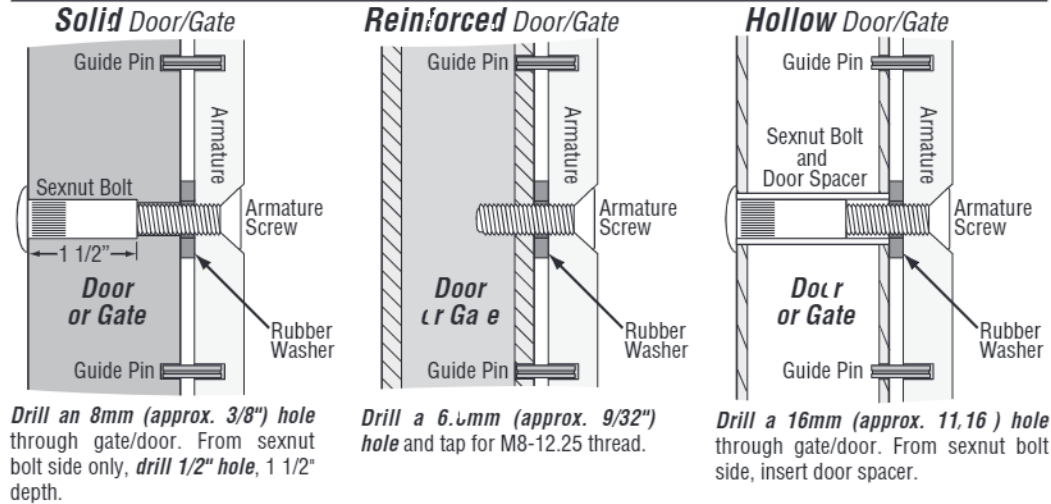

Hardware Parts List

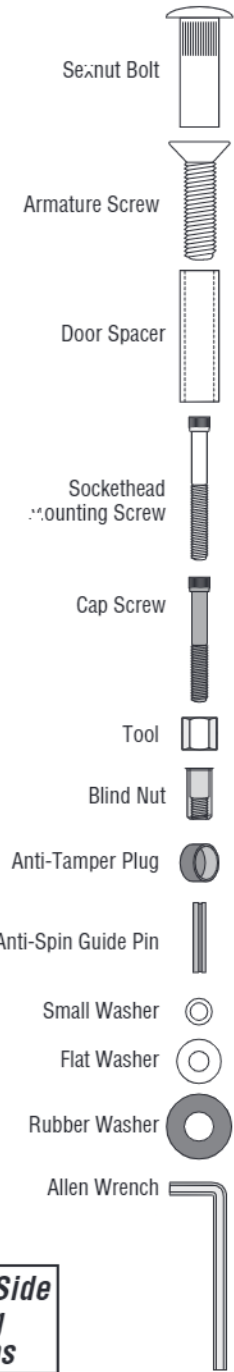

STEP 3: In order to mount the Magnetic lock, Blind nuts are included along with a tool to install them. The blind nut collapses when cap screw is turned with Allen wrench and tool is held fast with box wrench. See illustration below. If applicable, install all blind nuts.

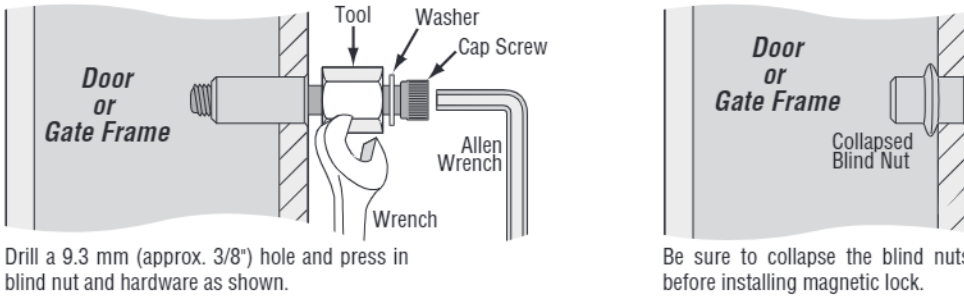

STEP 4: Firmly tighten all screws through Magnetic Lock to application. Install anti-tamper plugs into holes covering each sockethead mounting screw, use soft hammer to avoid damaging lock case. See illustration C. on opposite page.

Note: Use Locktite on screw threads to avoid the possibility of screws loosening over time.

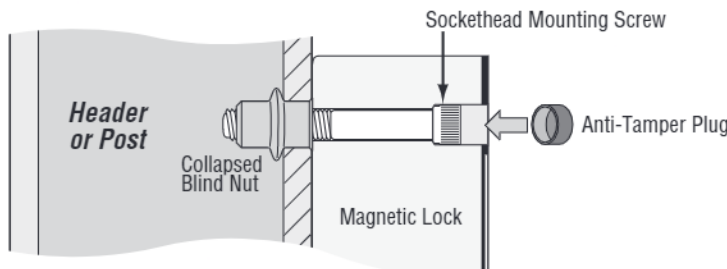

See Reverse Side for Wiring Instructions