

WARNING

To prevent possible SERIOUS INJURY or DEATH, disconnect electric power to operator BEFORE installing.
ALL installations and electrical connections MUST be made by a qualified individual.

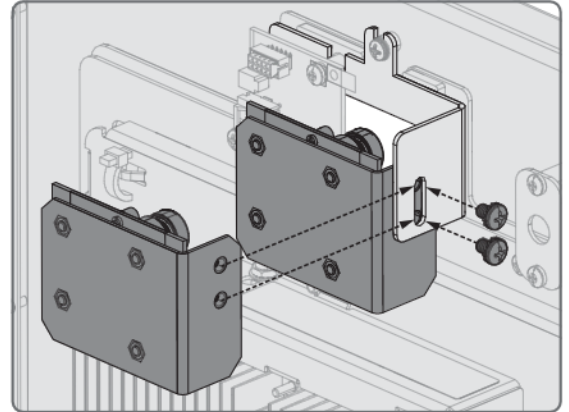

WARNING: This product can expose you to chemicals including lead, which are known to the State of California to cause cancer or birth defects or other reproductive harm. For more information go to www.P65Warnings.ca.gov.



Prior to Camera Installation

NOTE: CAPXLCAM is the only USB camera supported by CAPXL and myQ[®] Business™ video features. CAPXLCAM is the only camera evaluated by UL for use with CAPXL.

- 1. Make note of all Internet connectivity settings before any firmware update.**
When updating firmware Internet settings will be deleted. Go to the CAPXL connection screen in admin mode and write down or take picture of settings.
- Ensure CAPXL is running **Firmware version 2.0** or higher. The CAPXL upgrade process requires a restart and could be non-functional for up to 30 minutes while this upgrade takes place. Please ensure the gates/doors are open or residents have an alternate means to enter to the community during this brief period prior to hitting the upgrade button in myQ[®] Business™. This may require a technician on site to ensure safe operation and resident flow.
- Turn off power by disconnecting the power input on the I/O board.
- Remove the protective LENS cover from the camera assembly lens.

NOTE: Camera lens cover must be removed prior to mounting in the CAPXL.

Carton Inventory

- Camera assembly
- Camera bracket
- USB cable
- Mounting hardware bag (2x Screws)

Recommended Tools

- Network Test Software
- Philips Screwdriver
- Network LAN Cable Tester
- Wi-Fi / Wi-Fi Hotspot
- Wi-Fi Analyzer App
- Pliers

Internet Requirements CAPXL / CAPXLV - Use the information below for router compatibility.

CAPXL/CAPXLV can be connected to a router via a wired connection or Wi-Fi. LiftMaster recommends a minimum upload/download speed of 5Mbps for each CAPXL/CAPXLV supporting video camera feeds.

NOTE: This upload speed should be met when considering usage of other devices on the network like cameras and computers.

CAPXL / CAPXLV Wi-Fi Security Compatibility

Compatible	Not Compatible
<ul style="list-style-type: none"> • WPA2-PSK (AES) (Recommended) 	<ul style="list-style-type: none"> • WPA2 Enterprise
<ul style="list-style-type: none"> • WPA2-PSK (TKIP) (Recommended) 	<ul style="list-style-type: none"> • WEP
<ul style="list-style-type: none"> • WPA2 Personal (Recommended) 	<ul style="list-style-type: none"> • Open (No password or encryption)
<ul style="list-style-type: none"> • WPA-PSK (AES) 	
<ul style="list-style-type: none"> • WPA-PSK (TKIP) 	

Additional Compatibility Considerations

- Don't use Wi-Fi extender devices. These may introduce latency in the connection leading to choppy or loss of reliable video transmission.
- If using a Wi-Fi signal strength tool or app, a continuous Wi-Fi signal strength connection of at least -65 DBM (numbers closer to zero are stronger strength) at the CAPXL / CAPXLV must be guaranteed to ensure an acceptable connection to the local network.
- Hidden network SSID's are not supported. The network must be selectable from the CAPXL / CAPXLV display.
- Wi-Fi networks requiring secondary authentication are not supported, for example, Hotels and airport Wi-Fi.
- When checking signal strength in CAPXL / CAPXLV admin mode, we recommend at least two bars, as shown on the CAPXL screen.
- If two bars are not available, relocate the router, the antenna or use accessory WFAEXT (Wi-Fi Antenna Extension Kit – 15') to move the CAPXL / CAPXLV antenna higher up or to a location resulting in two or more bars.

Installation

1. Open CAPXL and remove the existing black camera bracket (top middle) by loosening and removing the wingnut.
2. Ensure CAPXL camera window is clean and free of any obstructions. Cleaning the camera window with a clean lens wipe or lens cloth is recommended.
3. Remove all items from shipping carton and ensure all required items are present: camera assembly, camera bracket, USB cable, and mounting hardware bag.
4. Use the mounting hardware to attach the new bracket with camera to the CAPXL. Securely tighten.
5. Use pliers to unplug the upper right dust plug from USB socket on control board (controller). (Figure 1.A)
6. **USB PORT #3 MUST BE USED** to connect the camera. The Micro USB end of the USB cable goes into the camera and the standard USB end of the cable specifically connects to USB port 3, (the upper right USB port on the controller.) (See Figure 1.B)
7. Route and secure USB cable with included tie-wraps. (Figure 2)
8. Turn on power to the CAPXL.
9. Enter CAPXL Admin Mode using the Dip Switch #1 on the Power/Internet board. Select the "Audio / Video" tab and confirm the video feed appears, and the angle and orientation are correct. (Figure 3)
10. Refer to the myQ® Business™ Quickstart Guide and visit the help section of the myQ® Business™ website for tutorial videos and further assistance with setting up the camera functions. Features such as the recording of events, the Guest View Feature, and more are set up within the myQ® Business™ account.

Access your myQ® Business™ account at:

<https://www.myQBusiness.com>

myQ® Business™ Help and Tutorial Videos:

<https://support.partner.liftmaster.com/s/community-access-support>

NOTES: Options such as live streaming within myQ® Business™ require an access control subscription. Please refer to the specific jurisdiction to determine if specific signage will be required for video use and monitoring.

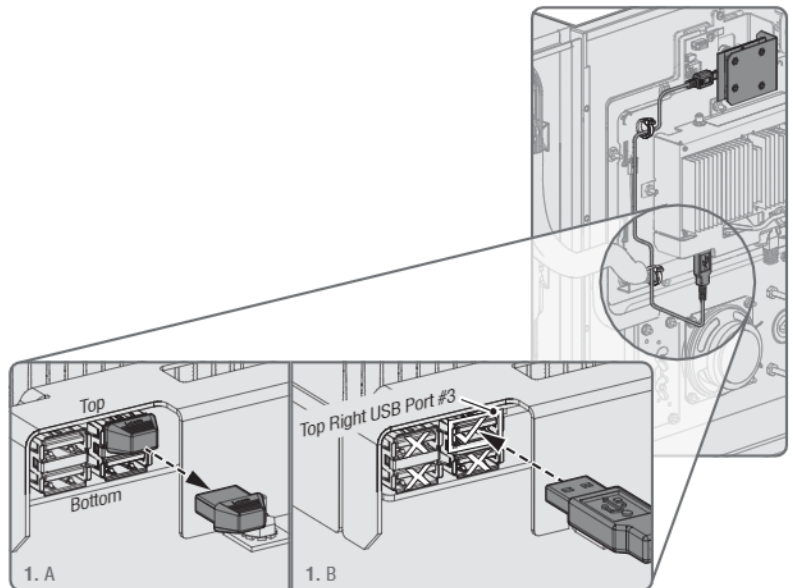

Figure 1. Removing the dust plug and connecting to USB Port #3 on the upper right side of the controller.

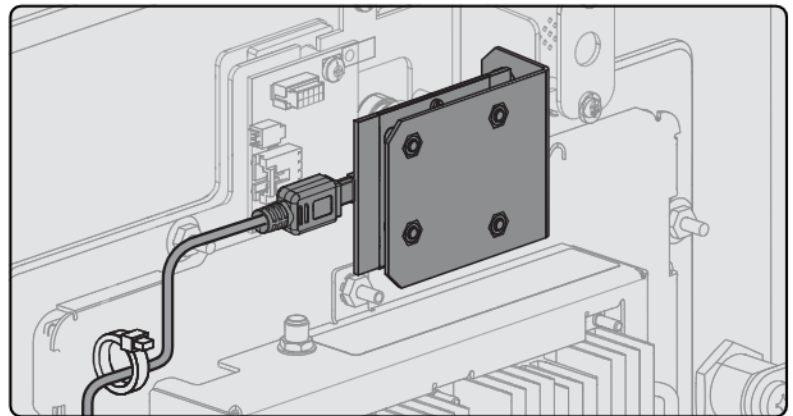

Figure 2. Routing the USB cable.

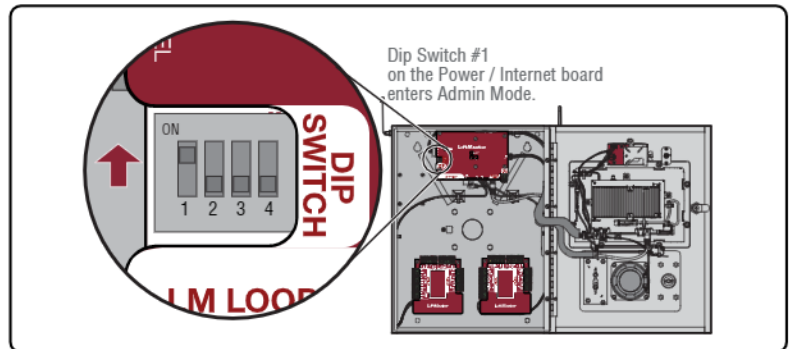

Figure 3. Admin Mode.

LiftMaster Support	Resources
Web	LiftMaster.com
Dealer Installation FAQ& myQ® Business™ Support Videos	https://support.partner.liftmaster.com/s/community-access-support
Commercial / Professional support: 877-247-6764	Mon-Fri 5:00 a.m. to 6:00 p.m. MST
LiftMaster Partner Portal	https://partner.liftmaster.com