

Installation/Owner's Manual

Model 1175

Commercial Overhead Gate/Door Operator

Use this manual for circuit board 4405-010 Revision AA or higher.

1175-065-F-12-17

EXTERNAL ENTRAPMENT PROTECTION MUST be installed or the gate/door operator WILL NOT function.

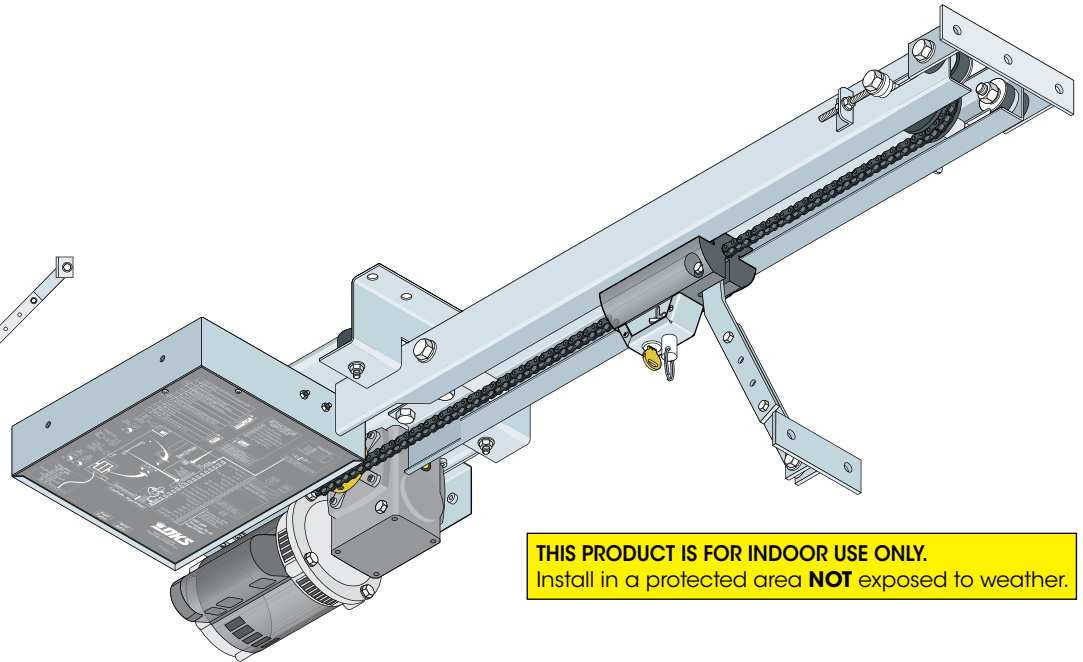
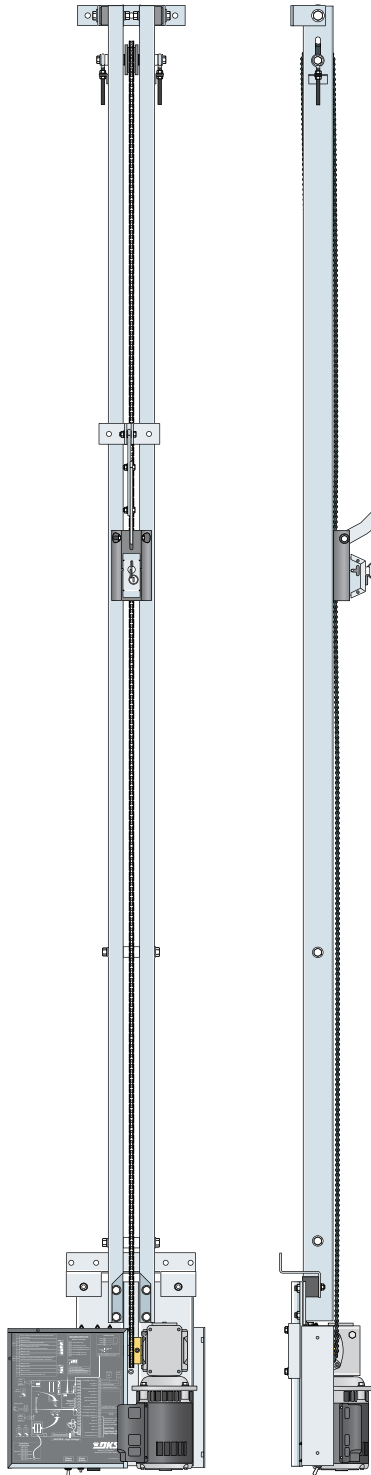

THIS PRODUCT IS FOR INDOOR USE ONLY.
Install in a protected area **NOT** exposed to weather.

THIS PRODUCT IS TO BE INSTALLED AND SERVICED BY A TRAINED GATE/DOOR SYSTEMS TECHNICIAN ONLY.
Visit www.dkslocator.com to find a professional installing and servicing dealer in your area.

Date Installed: _____

Installer/Company Name: _____

Phone Number: _____

Circuit Board
Serial Number
and Revision Letter: _____

Leave Manual with Owner

Copyright 2017 DoorKing, Inc. All rights reserved.



UL 325 Compliant



Copyright 2017 DoorKing, Inc. All rights reserved.

QUICK GUIDE: DIP-Switches

The two DIP-switches located on the circuit board are used to program the operator to operate in various modes and to turn on or off various operating features. Whenever a switch setting is changed, power to the operator must be turned OFF and then turned back on for the new setting to take affect. Check and review ALL switch settings prior to applying power to the operator.

SW 1 (Top 8 Switches)			
Switch	Function	Setting	Description
1	Opening Direction	MUST be in ON Position.	
2	OFF	Leave in OFF Position.	
3	Exit Loop Port Output	OFF	The output wired to terminal #4 becomes the output from the exit loop detector plugged into the EXIT Loop port.
	Full Open Input	ON	Normal Setting. Terminal #4 is a normal full open input.
4	Auto-Close Timer	OFF	Auto-close timer is OFF. Manual input required to close gate/door.
		ON	Normal Setting. Auto-close timer is ON. Adjustable from 1-23 seconds.
5	OFF	Leave in OFF Position.	
6	OFF	Leave in OFF Position.	
7 and 8	Circuit Board Relay	7-OFF 8-OFF	Normal Setting. Relay activates when gate/door is at open limit.
		7-OFF 8-ON	Relay activates when gate/door is not closed.
		7-ON 8-OFF	Relay activates when gate/door is opening and open.
		7-ON 8-ON	Relay activates during opening and closing cycle.

Switch 1 Must OPEN upon initial AC power up and open command. Set to **ON** Position.

Switch 2 Leave in **OFF** position.

Switch 3 Determines that a device wired to terminal #4 is a normal full open command **OR** terminal #4 becomes the output from the exit loop detector that is plugged into the EXIT Loop port in the circuit board (Used for specialized functions).

Switch 4 Turns the auto-close timer on or off. Maximum time that the close timer can be set for is approximately 23 seconds.

Switch 5 Leave in **OFF** position.

Switch 6 Leave in **OFF** position.

Switches 7-8 These work in conjunction with each other and determine when the relay on the board will be activated. This relay can be used as a switch for various functions such as illuminating a warning light when the gate/door is moving, or turning on a green light when the gate/door is full open.

SW 2 (Bottom 4 Switches)			
Switch	Function	Setting	Description
1	OFF	Leave in OFF Position.	
2	Magnetic lock	OFF	Normal Setting. Magnetic lock is not used.
		ON	Magnetic lock is used and connected to terminals 9 and 13. See page 17 for wiring.
3	ON	Switch 3 MUST be in ON Position.	
4	OFF	Switch 4 MUST be turned OFF for Model 1175 operator.	

Switch 1 Leave in **OFF** position.

Switch 2 If a magnetic lock is not used with the gate/door operator, leave this switch in the OFF position. Turn this switch ON if a magnetic lock is used and connected to terminals 9 and 13. This applies magnetic lock power and logic to these terminals (NC).

Switch 3 MUST be in **ON** position.

Switch 4 MUST be turned **OFF** for the Model 1175.

See page 17 for terminal wiring.

QUICK GUIDE: Terminal Descriptions

4-Pin Non-Removable Terminal

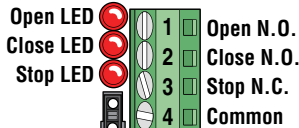

Jumper on **bottom** 2 pins when using 4-pin terminal.

Jumper on **top** 2 pins when **NOT** using 4-pin terminal.

- Use a standard **4-wire** 3-button control station mounted at least 5 ft above of the floor and at least 6 ft from gate/door. See page 13 for info about installation. (DoorKing's **3-wire** 3-button control station **cannot** be used)

- When using a 3-button control station **AND** an interlock device together, #3 terminal (N.C.) must be wired in series.

- See page 17 for wiring.

- If SW 1, **switch 3** is **ON**, functions as a normal full open input (Normal setting).

- If SW 1, **switch 3** is **OFF**, input to terminal #4 becomes the output from the EXIT loop detector plugged into the EXIT loop port. (Used for specialized functions).

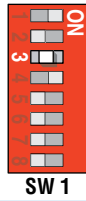

20-Pin Main Terminal

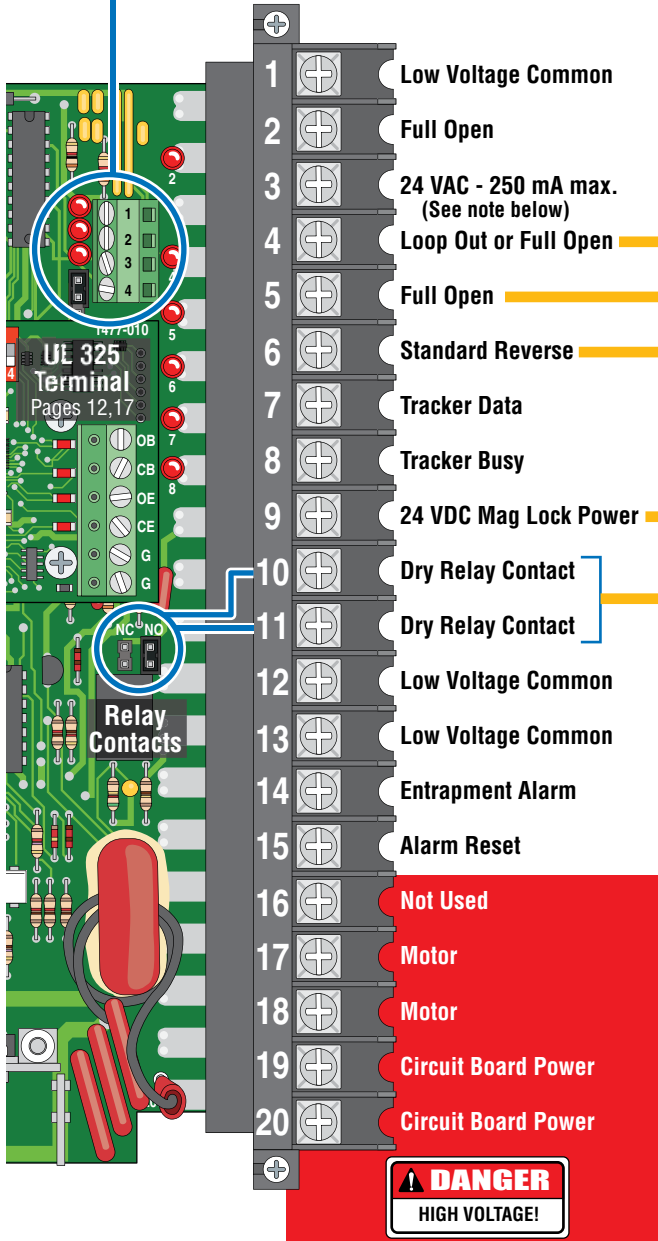

DANGER
HIGH VOLTAGE!

- When gate/door is closed, input will open gate/door.
- When gate/door is open and auto close timer SW 1, switch 4 is turned **ON**, input will re-set and hold timer.
- When gate/door is open and auto close timer SW 1, switch 4 is turned **OFF**, input will close gate/door.
- When gate/door is closing, input will reverse gate/door.



This input **ONLY** functions when gate/door is **fully opened** or in the **closing cycle**.

- When gate/door is closing: SW 1, **switch 5** is **OFF**, an input to terminal #6 (e.g.: photo beam gets obstructed) will stop and **reverse** and the gate/door to the full open position. **Note:** If the auto-close timer is **ON**, when gate/door reaches the open position, timer **will not** close the gate/door. Another input command is needed to reset and close the gate/door (Normal Setting).

- SW 1, **switch 5 ON, NOT** used for gate/door operator.



24-volt DC magnetic lock power is provided constantly except when the gate/door is **opening** or **open** (Normally Closed function). 1 Amp Max.

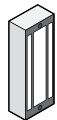

Operation of the circuit board dry relay contact is dependent on setting of SW 1, **switches 7 and 8**. **Relay contacts** can be set for Normally Open (NO) or Normally Closed (NC) operation.

Contact rating is 1 amp maximum at 24-volts DC.

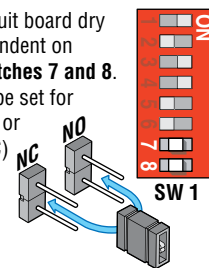

Main Terminal #3 Note:

Exceeding 250 mA of power from this terminal may cause the circuit board transformer to overheat, causing intermittent problems.

SPECIFICATIONS

THIS PRODUCT IS FOR INDOOR USE ONLY.
Install in a protected area **NOT** exposed to weather.

For the Model 1175 with circuit board 4405-010 Rev AA or higher ONLY.

Class of Operation _____ Model 1175 - UL325 Class II, III and IV
Type of Opening _____ Vehicular high traffic gate/door only.
Horsepower/ Voltage / Phase _____ ½ HP - 115 VAC - 60 Hz. Single-Phase
Current _____ 5.4 Amps
Max Gate/Door Dimensions _____ Height - 14 Feet, Width - 25 Feet
Gear Reduction _____ 40:1 Worm gear in a continuous oil bath.
Chain Type _____ #40
Cycles Per Hour _____ Continuous Duty
Speed _____ Approximately 10 inches per second

Inherent Entrapment Protection Device:

Inherent Reverse Sensor System (Type A)

External Entrapment Protection Device Inputs (Monitored Inputs):

Monitored connection inputs for Non-contact Sensor - Photo Sensor (Type B1)

Monitored connection input for Contact Sensor - Reversing Edge (Type B2)

Installation of ONE external MONITORED entrapment protection device MUST be installed or operator WILL NOT function.

TWO (2) Entrapment Protection Devices are REQUIRED for UL 325 compliance. Type B1 and B2 MUST be MONITORED when used.

Rail Part Number	Max. Gate/Door Height	Dimension A
1150-225	8 feet	12 feet 5 inches
1150-226	10 feet	14 feet 5 inches
1150-227	12 feet	16 feet 5 inches
1150-228	14 feet	18 feet 5 inches

IF the operator MUST be installed less than 2.44 m (8 feet) above the floor, then exposed moving parts must be protected by covers or guarding, provided by the operator manufacturer.

DoorKing offers a 1175 cover to protect against anyone from coming in contact with the operator's exposed moving parts. Sold separately, P/N 1175-020

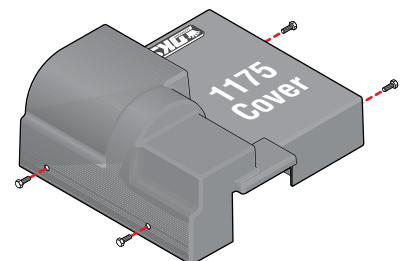

DoorKing, Inc. reserves the right to make changes in the products described in this manual without notice and without obligation of DoorKing, Inc. to notify any persons of any such revisions or changes. Additionally, DoorKing, Inc. makes no representations or warranties with respect to this manual. This manual is copyrighted, all rights reserved. No portion of this manual may be copied, reproduced, translated, or reduced to any electronic medium without prior written consent from DoorKing, Inc.

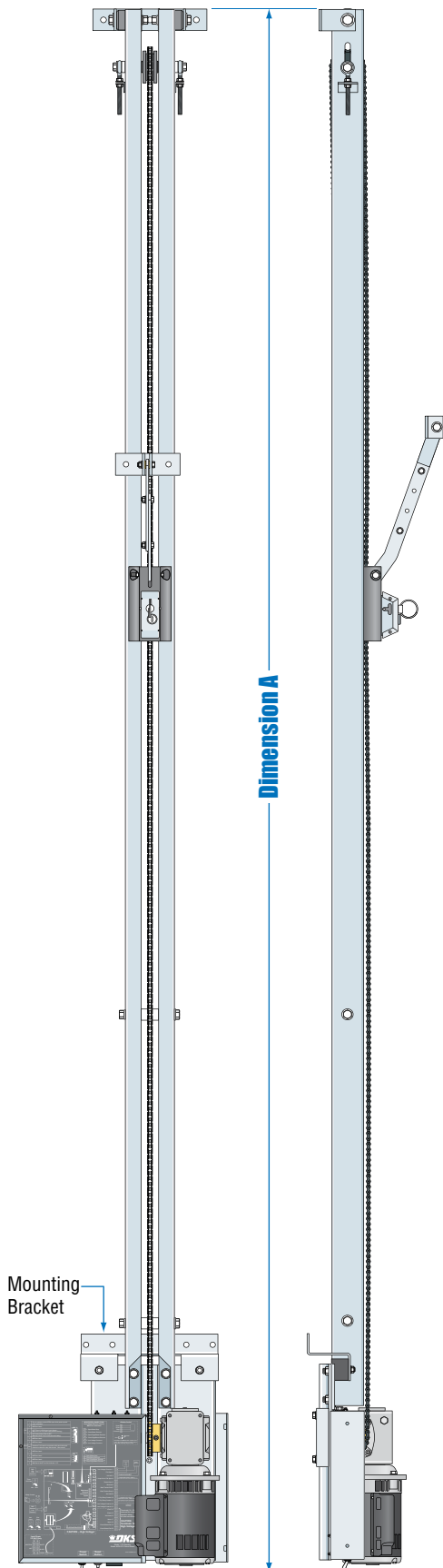

TABLE OF CONTENTS

QUICK GUIDES

Quick Guide: DIP-Switches	Quick Guide - 1
Quick Guide: Terminal Descriptions	Quick Guide - 2

SPECIFICATIONS

	Previous Page
Overhead Gate/Door Protection	2
Gate/Door Construction	3
Important Safety Instructions	3
Instructions regarding intended installation:	3-4
Important Notices	4
UL325 Entrapment Protection	5
Glossary	6

SECTION 1 - INSTALLATION

7

1.1 Determine Location of Operator	7
1.2 Attach Rails to Powerhead	7
1.3 Manual Release and Chain Connection	8
1.4 Adjust Chain Tension	8
1.5 Attach Gate/Door Bracket	9
1.6 Attach Header Bracket	9
1.7 Mount Operator	10-11
1.8 External Entrapment Protection Installation	12
1.9 3-Button Control Station Installation	13

SECTION 2 - WIRING

14

2.1 Conduit Requirements	14
2.2 High Voltage Wire Run	15
2.3 High Voltage Terminal Connection	15
2.4 Main Terminal Description	16
2.5 Control Wiring	17
2.6 External Entrapment Protection Wiring	18
2.7 Loop Detector Wiring	19

SECTION 3 - ADJUSTMENTS

20

3.1 Circuit Board Adjustments	20
3.2 DIP-Switch Descriptions and Functions	21
3.3 Limit Sensor Adjustments	22
3.4 Inherent Reverse Sensor Adjustment	23

SECTION 4 - OPERATING INSTRUCTIONS

24

4.1 Power Switch and Alarm Reset Switch	24
4.2 Shutdown Conditions	25-26
4.3 Manual Gate/Door Operations	26-27

SECTION 5 - TECHNICAL INSTRUCTIONS

28

5.1 Maintenance Schedule	28
5.2 Diagnostics Check	28-29
5.3 Troubleshooting	29-30
5.4 Accessories	31
1175 Wiring Schematic	32

Overhead Gate/Door Protection

One or more contact or non-contact external MONITORED entrapment protection systems shall be located where the risk of entrapment or obstruction exists at either the opening or closing direction. Care shall be exercised to reduce the risk of nuisance tripping, such as when a vehicle trips the sensor while the gate/door is still moving.

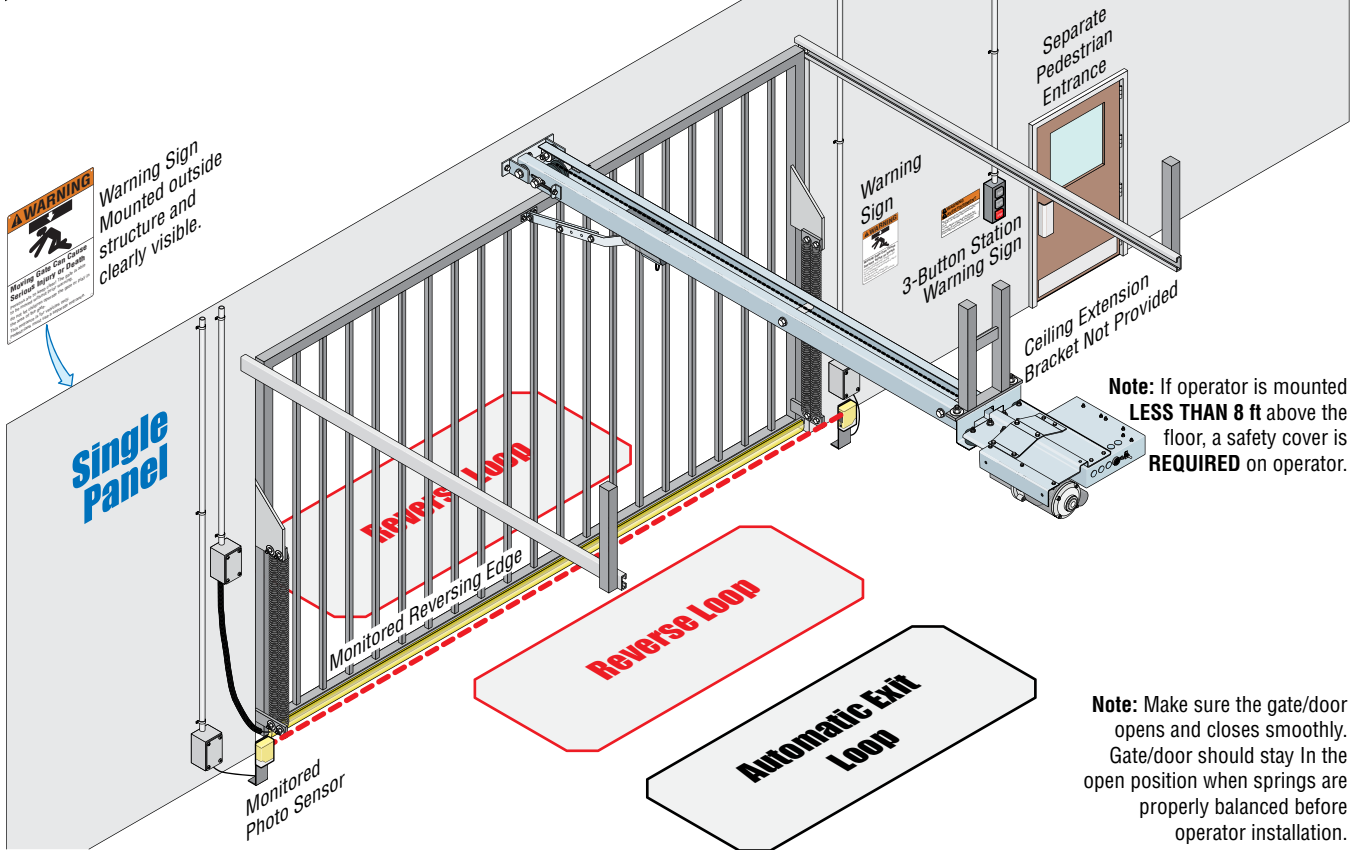
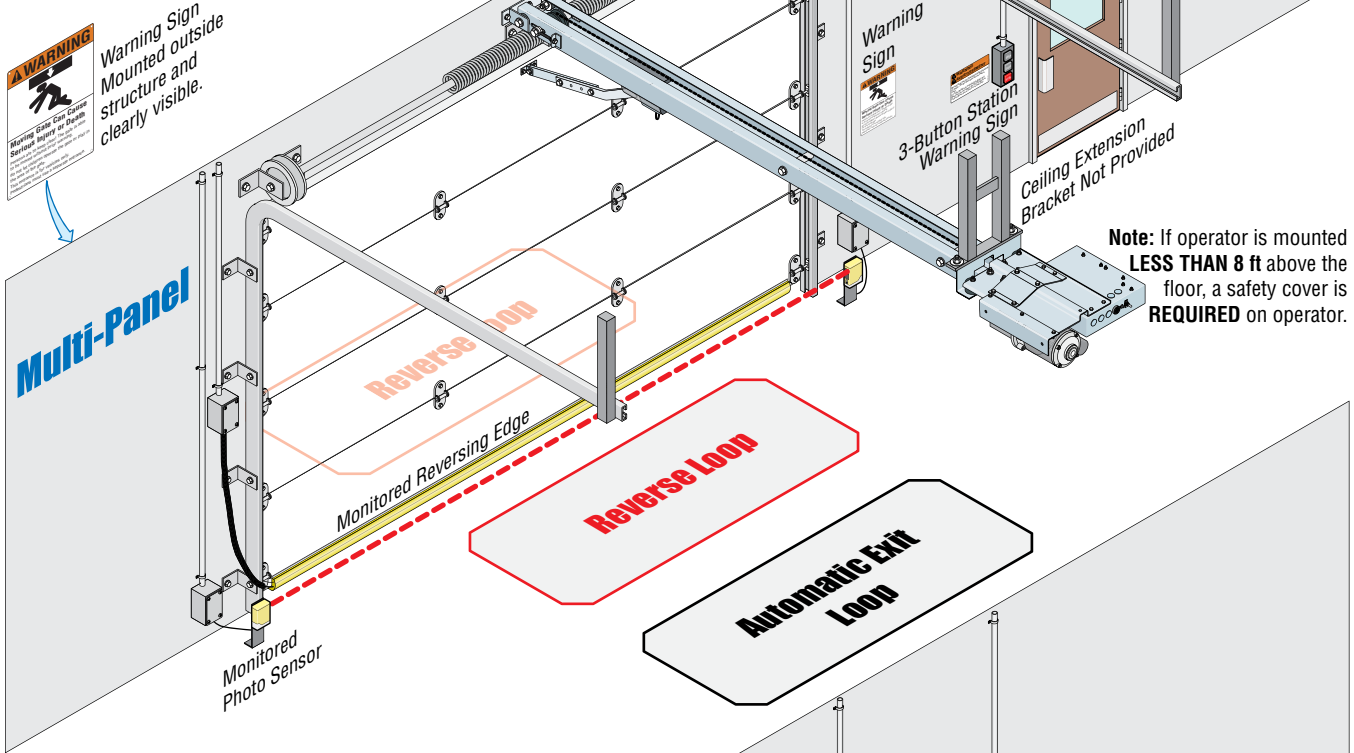

ASTM F2200 Standard for Gate/Door Construction

Vehicular gates should be constructed and installed in accordance with ASTM F2200; Standard Specification for Automated Vehicular Gate/Door Construction. For a copy of this standard, contact ASTM directly at 610-832-9585; service@astm.org; or www.astm.org.

Important Safety Instructions

WARNING – To reduce the risk of injury or death:

1. READ AND FOLLOW ALL INSTRUCTIONS.
2. Never let children operate or play with gate/door controls. Keep remote controls (when provided) away from children.
3. Personnel should keep away from the gate/door in motion and keep the moving gate/door in sight until it is completely closed or opened.

NO ONE SHOULD CROSS THE PATH OF A MOVING GATE/DOOR.

4. Test the gate/door safety features at least once a month. After adjusting either the force or the limit of travel, retest the gate/door operator's safety features. Failure to adjust the operator properly may cause severe injury or death.
5. Use the manual release only when the gate/door is closed. Use caution when using this release when the gate/door is open. Weak or broken springs may cause the gate/door to fall rapidly, causing severe injury or death.
6. KEEP GATE/DOOR PROPERLY OPERATING AND BALANCED. Refer to the hardware manufacturer's User Manual. An improperly operating or balanced gate/door could cause severe injury or death. Have a trained technician make repairs to cables, spring assemblies, and other hardware.
7. **SAVE THESE INSTRUCTIONS.**

Important Installation Instructions

WARNING – To reduce the risk of injury or death:

1. READ AND FOLLOW ALL INSTRUCTIONS.
2. Install only on a properly operating and balanced overhead gate/door. An overhead gate/door that is operating improperly could cause severe injury. Have qualified service personnel make repairs to cables, spring assemblies, and other hardware before installing the operator.
3. Remove all pull ropes and remove, or make inoperative, all locks (unless mechanically and/or electrically interlocked to the power unit) connected to the gate/door before installing the operator.
4. A commercial/industrial overhead gate/door operator that has exposed moving parts capable of causing injury to persons or employs a motor deemed indirectly accessible by virtue of its location above the floor shall include:
 - a. Install the gate/door operator at least 2.44 m (8 feet) or more above the floor; or
 - b. If the operator must be installed less than 2.44 m (8 feet) above the floor, then exposed moving parts must be protected by covers or guarding, provided by the operator manufacturer; or
 - c. Both (a) and (b).
5. Use the manual release only when the gate/door is closed. Use caution when using this release when the gate/door is open. Weak or broken springs may cause the gate/door to fall rapidly, causing severe injury or death.
6. KEEP GATE/DOOR PROPERLY OPERATING AND BALANCED. Refer to the hardware manufacturer's User Manual. An improperly operating or balanced gate/door could cause severe injury or death. Have a trained technician make repairs to cables, spring assemblies, and other hardware.
7. **SAVE THESE INSTRUCTIONS.**

Instructions regarding intended installation:

- Install the gate/door operator only if:
 1. The operator is appropriate for the construction of the gate/door and the usage class of the gate/door.
 2. All openings of a horizontal slide gate are guarded or screened from the bottom of the gate to a minimum of 6 feet (1.83 m) above the ground to prevent a 2 ¼ inch (57.2 mm) diameter sphere from passing through the openings anywhere in the gate, and in that portion of the adjacent fence that the gate covers in the open position.
 3. All exposed pinch points are eliminated or guarded.
 4. Guarding is supplied for exposed rollers.
- The operator is intended for installation only on gates/doors used for vehicles. Pedestrians must be supplied with a separate access opening. The pedestrian access opening shall be designed to promote pedestrian usage. Locate the gate/door such that persons will not come in contact with the vehicular gate/door during the entire path of travel of the vehicular gate/door.
- The gate/door must be installed in a location so that enough clearance is supplied between the gate/door and adjacent structures when opening and closing to reduce the risk of entrapment. Swinging gates/doors should not open into public access areas.
- The gate/door must be properly installed and work freely in both directions prior to the installation of the gate/door operator. Do not over-tighten the operator clutch, pressure relief valve or reduce reversing sensitivity to compensate for a damaged gate/door.
- For gate/door operators utilizing Type D protection:
 1. The gate/door operator controls must be placed so that the user has full view of the gate/door area when the gate/door is moving.
 2. A warning placard shall be placed adjacent to the controls.
 3. An automatic closing device (such as a timer, loop sensor, or similar device) shall not be employed.
 4. No other activation device shall be connected.

Continued on next page.

Continued from previous page.

- Controls intended for user activation must be located at least six feet (6') away from any moving part of the gate/door and where the user is prevented from reaching over, under, around or through the gate/door to operate the controls. Outdoor or easily accessible controls should have a security feature to prevent unauthorized use.
- The Stop and/or Reset button must be located in the line-of-sight of the gate/door. Activation of the reset control shall not cause the operator to start.
- A minimum of two (2) WARNING SIGNS shall be installed, one on each side of the gate/door where easily visible.
- For gate/door operators utilizing a non-contact sensor:
 1. See the instructions on the placement of non-contact sensors for each type of application.
 2. Care shall be exercised to reduce the risk of nuisance tripping, such as when a vehicle trips the sensor while the gate/door is still moving in the opening direction.
 3. One or more non-contact sensors shall be located where the risk of entrapment or obstruction exist, such as the perimeter reachable by a moving gate/door or barrier.
- For gate operators utilizing contact sensors:
 1. One or more contact sensors shall be located where the risk of entrapment or obstruction exist, such as at the leading edge, trailing edge, and post mounted both inside and outside of a vehicular horizontal slide gate.
 2. One or more contact sensors shall be located at the bottom edge of a vehicular vertical lift gate/door.
 3. One or more contact sensors shall be located at the pinch point of a vehicular vertical pivot gate/door.
 4. A hardwired contact sensor shall be located and its wiring arranged so that the communication between the sensor and the gate/door operator is not subjected to mechanical damage.
 5. A wireless contact sensor such as one that transmits radio frequency (RF) signals to the gate/door operator for entrapment protection functions shall be located where the transmission of the signals are not obstructed or impeded by building structures, natural landscaping or similar obstructions. A wireless contact sensor shall function under the intended end-use conditions.
 6. One or more contact sensors shall be located at the bottom edge of a vertical barrier (arm).

Important Notices

Vehicular gate/door operator products provide convenience and security. However, gate/door operators must use high levels of force to move gates/doors and most people underestimate the power of these systems and do not realize the potential hazards associated with an incorrectly designed or installed system. These hazards may include:

- Pinch points
- Entrapment areas
- Reach through hazards
- Absence of entrapment protection devices
- Improperly located access controls
- Absence of vehicle protection devices
- Absence of controlled pedestrian access

In addition to these potential hazards, automated vehicular gate/door systems must be installed in accordance with the UL 325 Safety Standard and the ASTM F2200 Construction Standard. Most people are unaware of, or are not familiar with, these standards. If an automated vehicular gate/door system is not properly designed, installed, used and maintained, serious injuries or death can result. Be sure that the installer has instructed you on the proper operation of the gate/door and gate/door operator system. Be sure that the installer has trained you about the basic functions of the required reversing systems associated with your gate/door operating system and how to test them. These include reversing loops, inherent reversing system, electric edges, photoelectric cells, or other external devices.

- This Owner's Manual is your property. Keep it in a safe place for future reference.
- Be sure that all access control devices are installed a minimum distance of 6 feet away from the gate/door and gate/door operator, or in such a way that a person cannot touch the gate/door or gate/door operator while using the device. If access control devices are installed in violation of these restrictions, immediately remove the gate/door operator from service and contact your installing dealer.
- Loops and loop detectors, photo-cells or other equivalent devices must be installed to prevent the gate/door from closing on vehicular traffic.
- The speed limit for vehicular traffic through the gate/door area is 5 MPH. Install speed bumps and signs to keep vehicular traffic from speeding through the gate/door area. Failure to adhere to posted speed limits can result in damage to the gate/door, gate/door operator, and to the vehicle.
- Be sure that all persons who will use the gate/door system are familiar with the proper use of the gate/door and gate/door operator and are familiar with the possible hazards associated with the gate/door system.
- Be sure that warning signs are permanently installed on both sides of the gate/door in an area where they are fully visible to traffic.
- It is your responsibility to periodically check all entrapment protection devices. If any of these devices are observed to function improperly, remove the operator from service immediately and contact your installing or servicing dealer.
- Follow the recommended maintenance schedule.
- Do not allow children to play in the area of the operator or to play with any gate/door-operating device.
- To remove the gate/door operator from service, operate the gate/door to the full open position and then shut off power to the operator at the service panel.



Opening device **MUST** be mounted a minimum of 6 feet from the gate/door and **NOT** accessible through the gate/door!

UL325 Entrapment Protection

UL 325 Classifications



Class I - Residential Vehicular Gate Operator

A vehicular gate operator (or system) intended for use in garages or parking areas associated with a residence of one-to four single families. This does **NOT** apply to DKS commercial gate operator.



Class III - Industrial/Limited Access Vehicular Gate/Door Operator

A vehicular gate/door operator (or system) intended for use in an industrial location or building such as a factory or loading dock area or other locations not accessible by or intended to service the general public.

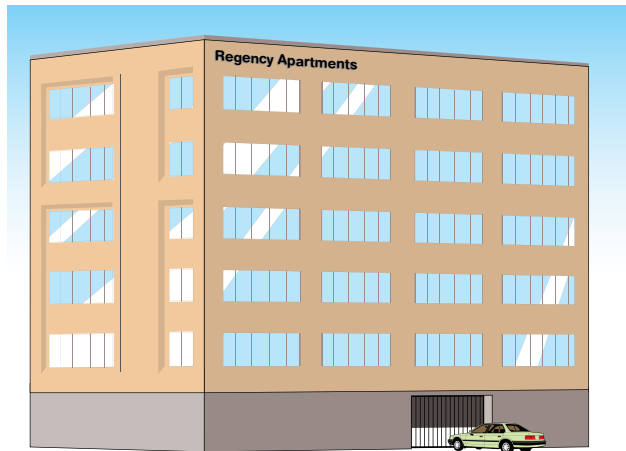

Class II - Commercial/General Access Vehicular Gate/Door Operator

A vehicular gate/door operator (or system) intended for use in a commercial location or building such as a multi-family housing unit (five or more single family units), hotel, garages, retail store, or other buildings accessible by or servicing the general public.



Class IV - Restricted Access Vehicular Gate/Door Operator

A vehicular gate/door operator (or system) intended for use in a guarded industrial location or building such as an airport security area or other restricted access locations not servicing the general public, in which unauthorized access is prevented via supervision by security personnel.

Gate/Door Operator Category

	Horizontal Slide, Vertical Lift, Vertical Pivot	Swing, Vertical Barrier (Arm)
Entrapment Protection Types	A, B1*, B2* or D	A, B1*, B2*, C or D

- Type A** - Inherent entrapment protection system.
- Type B1** - Non-contact sensor (photoelectric sensor or the equivalent).
- Type B2** - Contact sensor (edge device or equivalent).
- Type C** - Inherent force limiting, inherent adjustable clutch or inherent pressure relief device.
- Type D** - Actuating device requiring constant pressure to maintain opening or closing motion of the gate/door.

* B1 and B2 means of entrapment protection must be MONITORED.

Vertical Barrier Note: Barrier gate operators (arm) that is not intended to move toward a rigid object closer than 16 inches (406 mm) are not required to be provided with a means of entrapment protection.

Glossary

GATE/DOOR - A moving barrier such as a swinging, sliding, raising, lowering, or the like, barrier, that is a stand-alone passage barrier or is that portion of a wall or fence system that controls entrance and/or egress by persons or vehicles and completes the perimeter of a defined area.

RESIDENTIAL VEHICULAR GATE OPERATOR – CLASS I - A vehicular gate operator (or system) intended for use in a home of one-to four single family dwelling, or garage or parking area associated therewith.

COMMERCIAL / GENERAL ACCESS VEHICULAR GATE OPERATOR - CLASS II - A vehicular gate operator (or system) intended for use in a commercial location or building such as a multi-family housing unit (five or more single family units), hotels, garages, retail store, or other building servicing the general public.

INDUSTRIAL / LIMITED ACCESS VEHICULAR GATE OPERATOR - CLASS III - A vehicular gate operator (or system) intended for use in an industrial location or building such as a factory or loading dock area or other locations not intended to service the general public.

RESTRICTED ACCESS VEHICULAR GATE OPERATOR - CLASS IV - A vehicular gate operator (or system) intended for use in a guarded industrial location or building such as an airport security area or other restricted access locations not servicing the general public, in which unauthorized access is prevented via supervision by security personnel.

VEHICULAR BARRIER (ARM) OPERATOR (OR SYSTEM) - An operator (or system) that controls a cantilever type device (or system), consisting of a mechanical arm or barrier that moves in a vertical arc, intended for vehicular traffic flow at entrances or exits to areas such as parking garages, lots or toll areas.

VEHICULAR HORIZONTAL SLIDE-GATE OPERATOR (OR SYSTEM) - A vehicular gate operator (or system) that controls a gate which slides in a horizontal direction that is intended for use for vehicular entrance and exit to a drive, parking lot, or the like.

VEHICULAR SWING-GATE OPERATOR (OR SYSTEM) - A vehicular gate operator (or system) that controls a gate which moves in an arc in a horizontal plane that is intended for use for vehicular entrance and exit to a drive, parking lot, or the like.

SYSTEM - In the context of these requirements, a system refers to a group of interacting devices intended to perform a common function.

WIRED CONTROL - A control implemented in a form of fixed physical interconnections between the control, the associated devices, and an operator to perform predetermined functions in response to input signals.

WIRELESS CONTROL - A control implemented in means other than fixed physical interconnections (such as radio waves or infrared beams) between the control, the associated devices, and an operator to perform predetermined functions in response to input signals.

INHERENT ENTRAPMENT PROTECTION SYSTEM - A system, examples being a motor current or speed sensing system, which provides protection against entrapment upon sensing an object and is incorporated as a permanent and integral part of the operator.

EXTERNAL ENTRAPMENT PROTECTION DEVICE - A device, examples being an edge sensor, a photoelectric sensor, or similar entrapment protection device, which provides protection against entrapment when activated and is not incorporated as a permanent part of an operator.

ENTRAPMENT - The condition when an object is caught or held in a position that increases the risk of injury.

SECTION 1 - INSTALLATION

Prior to beginning the installation of the commercial gate/door operator, we suggest that you become familiar with the instructions, illustrations, and wiring guide-lines in this manual. This will help insure that your installation is performed in an efficient and professional manner compliant with UL 325 safety and ASTM F2200 construction standards.

The proper installation of the vehicular commercial gate/door operator is an extremely important and integral part of the overall access control system. Check all local building ordinances and building codes prior to installing this operator. Be sure your installation is in compliance with local codes.

1.1 Determine Location of Operator

IMPORTANT: Make sure the gate/door opens and closes smoothly **BEFORE** installing operator. Gate/door should **REMAIN** in the open position when balancing springs are properly adjusted.

IF the operator is installed less than 8 feet above the floor, then operator's exposed moving parts must be covered. DoorKing offers a 1175 cover for protection, Sold separately, P/N 1175-020

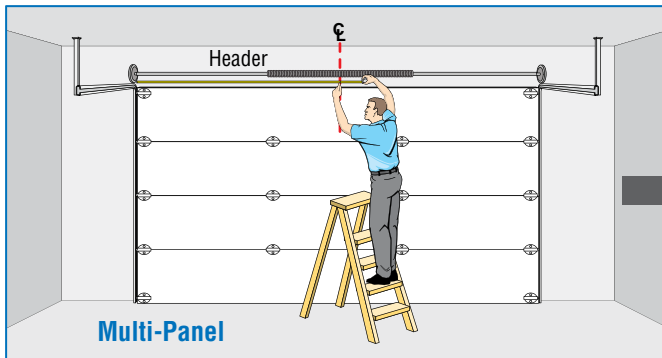
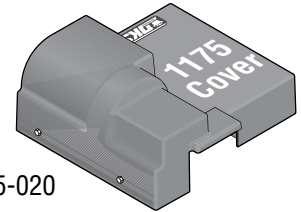

1. With the gate/door **CLOSED**, measure and mark a centerline of the gate.

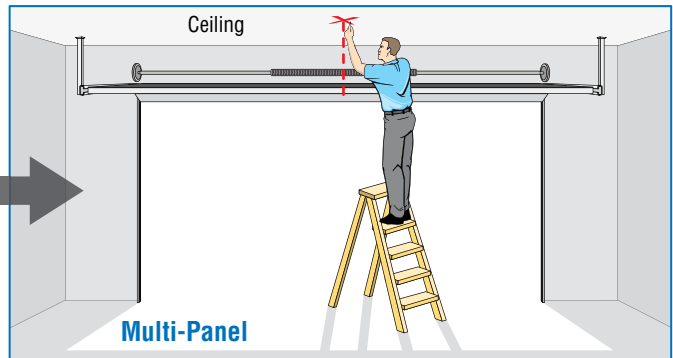

2. With the gate/door **OPEN**, mark a centerline of the gate on the ceiling.

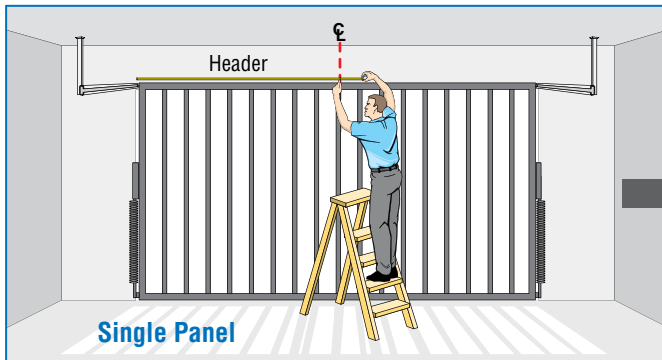

THIS PRODUCT IS FOR INDOOR USE ONLY.
Install in a protected area **NOT** exposed to weather.

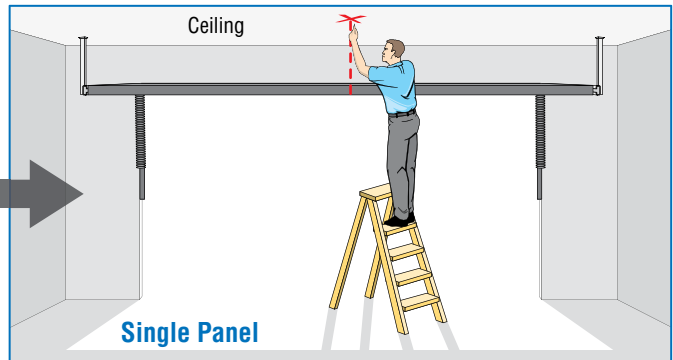

1.2 Attach Rails to Powerhead

Secure rails to powerhead with 4 bolts, nuts and lockwashers.

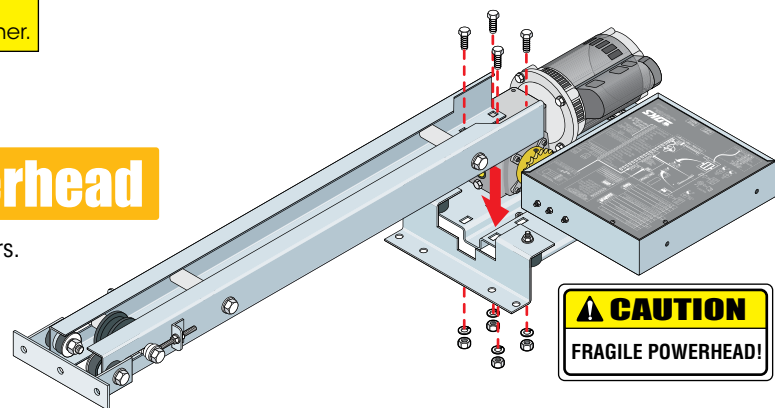

1.3 Manual Release and Chain Connection

Cut wire ties and route chain around gear reducer's sprocket and through unlocked carriage assembly (To unlock assembly, use key to unlock release ring, pull ring up and rotate 45° to release spring loaded chain catch). Connect chain together with double master link.

1 Unlock

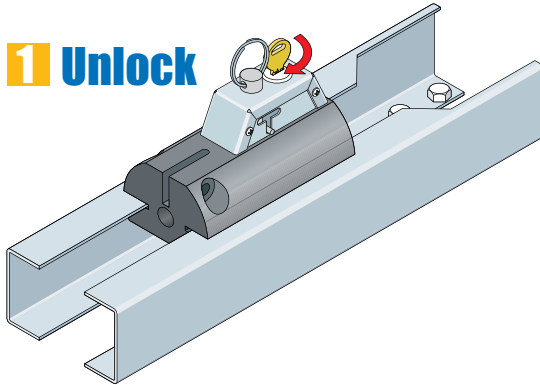

IMPORTANT: The carriage assembly's spring loaded chain catch will only lock into place in the double master chain link.

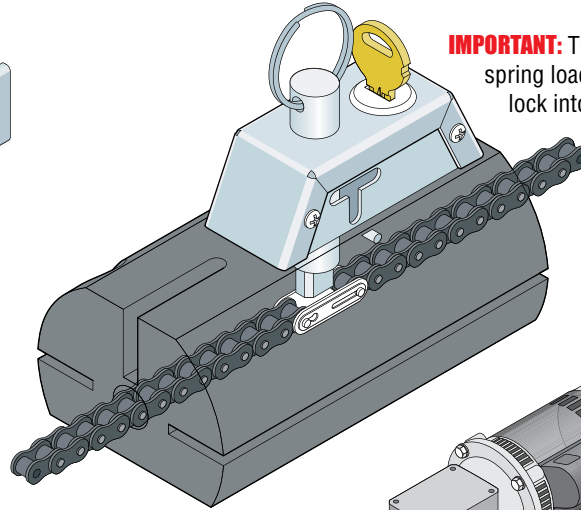

2 Pull Up and Turn Ring

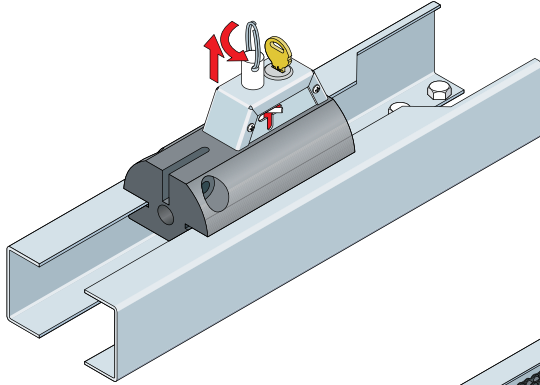

Sprocket

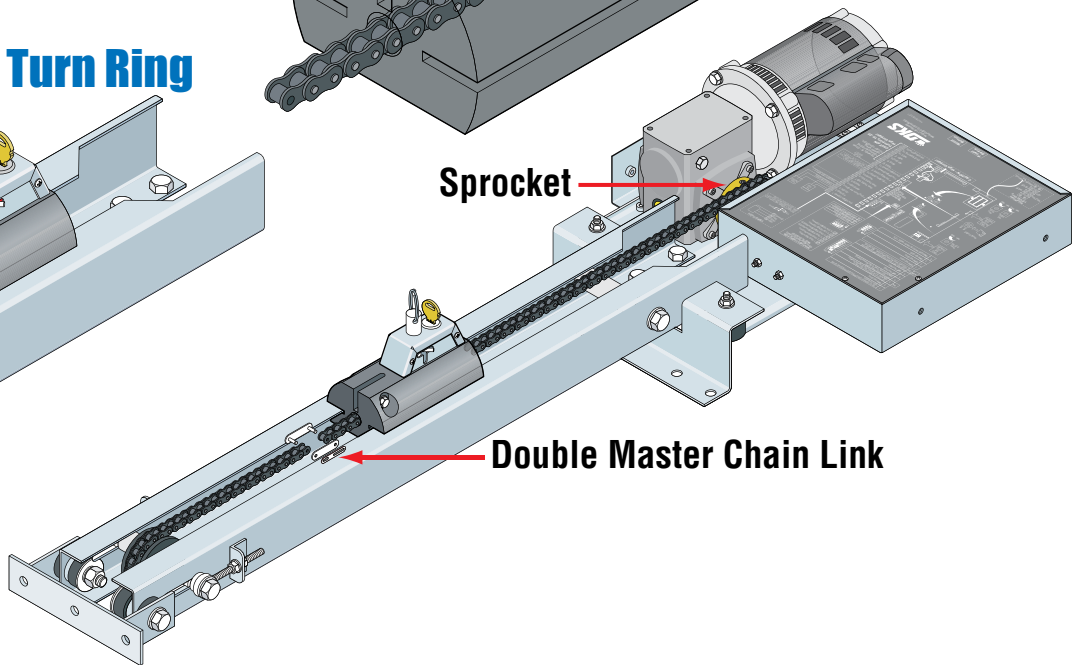

Double Master Chain Link

1.4 Adjust Chain Tension

Do not overtighten chain. Make adjustments equally on both sides of rails. Chain will need final adjustment after operator has been mounted. Chain will stretch over time and will need to be tightened.

Do not let chain touch steel rail separators.

Approximate chain tension, front rail removed for illustration.

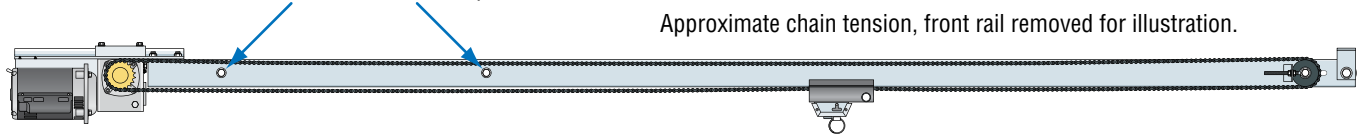

Chain must be centered between rails.

Return wheel must be centered between rails.

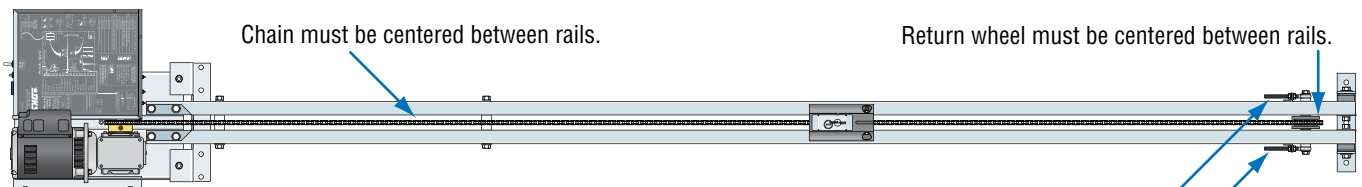

Chain tension adjustment. Adjust equally on both sides of rails.

1.5 Attach Gate/Door Bracket

Install the gate/door bracket on the top of the gate/door. Use appropriate hardware, not included. **Bracket must be mounted level and centered on gate/door!**

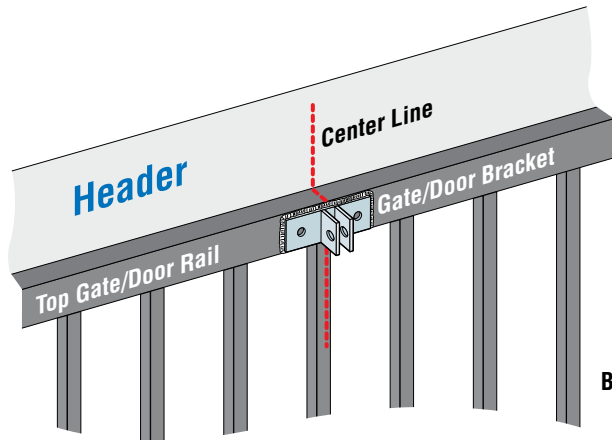

Single Panel

Typically welded, completely weld around bracket

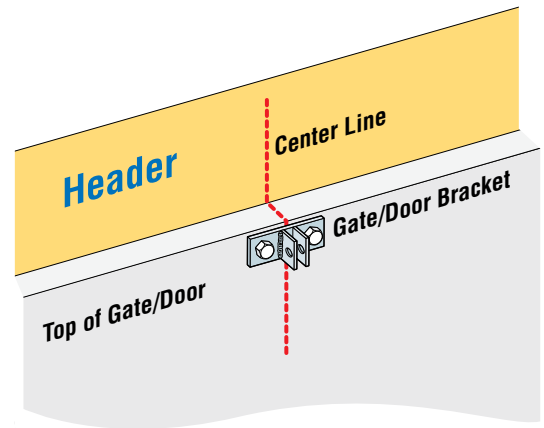

Multi-Panel

Typically bolted

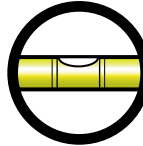

Bracket must be mounted level!

1.6 Attach Header Bracket

Header bracket should be mounted on the center line a **MINIMUM of 2.5 inches** from highest point of the gate/door in the open position (see below). Use appropriate hardware, not included. **Header bracket must be level and SECURELY mounted.**

Header Bracket Assembly

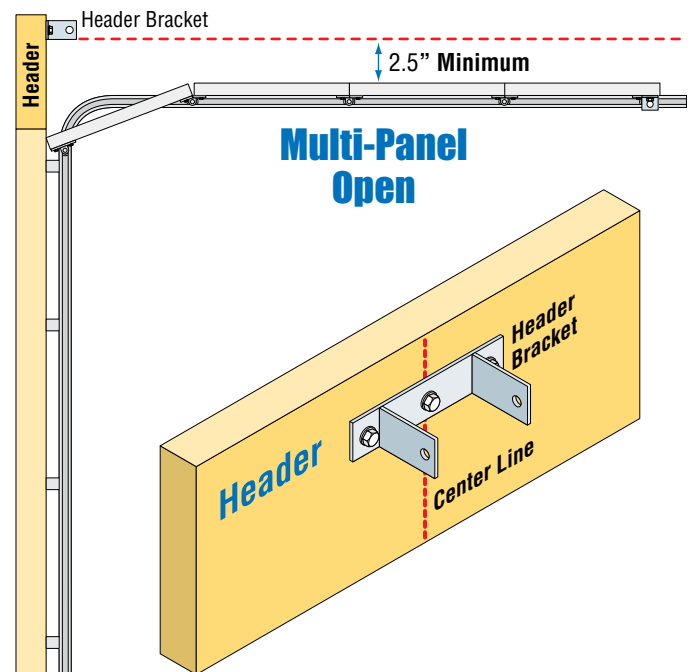
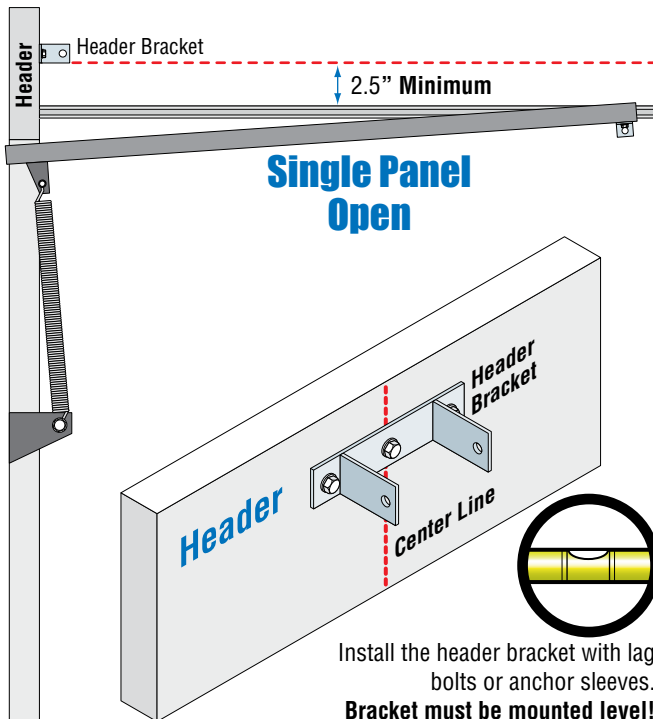
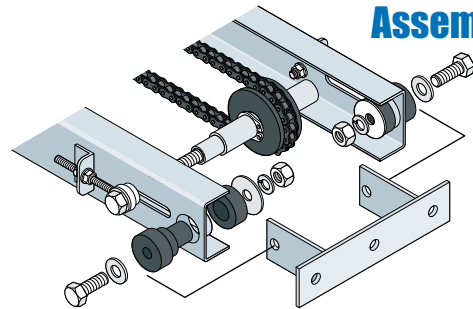

Install the header bracket with lag bolts or anchor sleeves.
Bracket must be mounted level!

1.7 Mount Operator

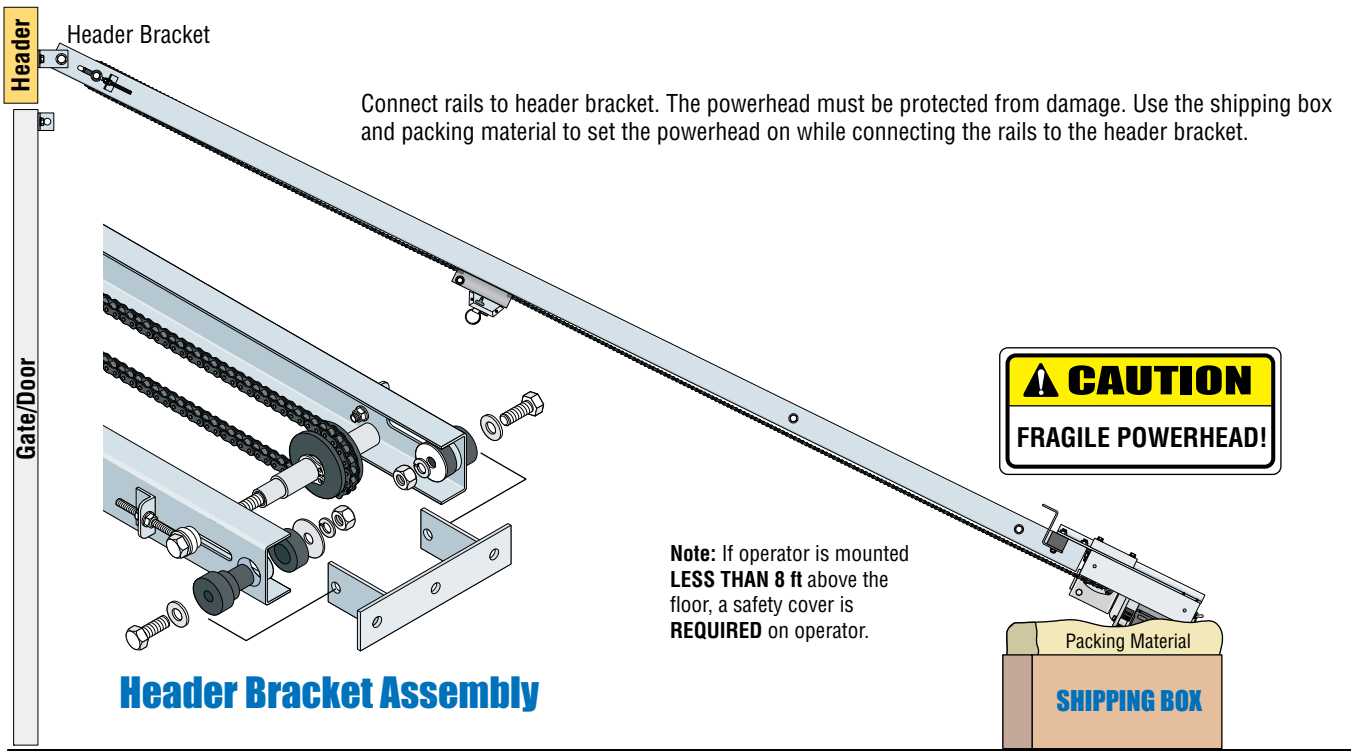

Mount Powerhead Directly to Ceiling

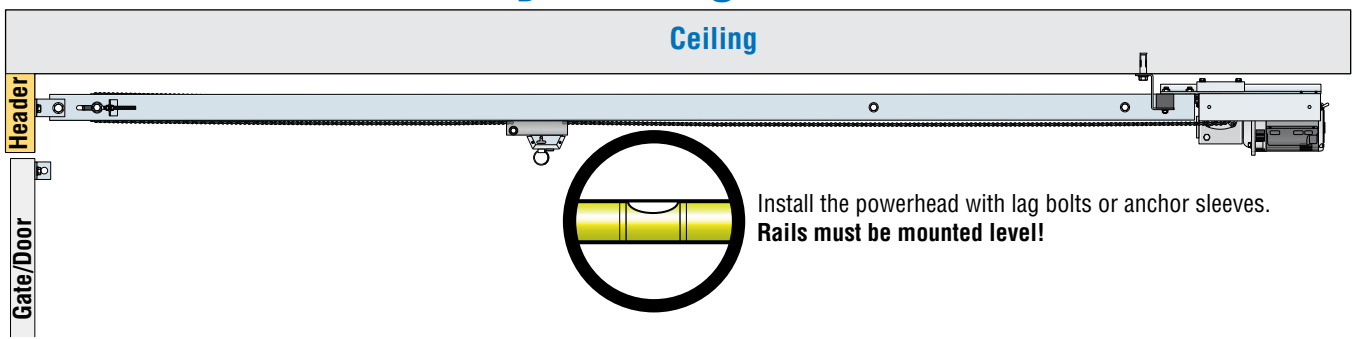

Mount Powerhead Using a Ceiling Extension Bracket

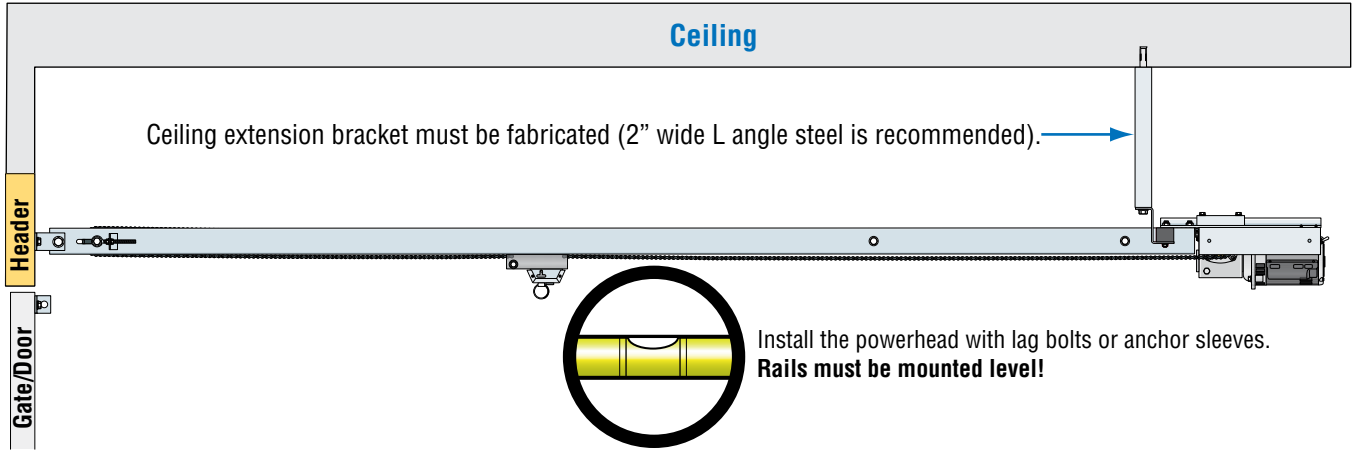

Connect Carriage Arm

Carriage assembly must be unlocked. After connecting the arm, manually raise and lower the gate/door, be sure the gate/door is operating smoothly and is not binding anywhere. Any interference must be corrected now.

Header

Gate/Door

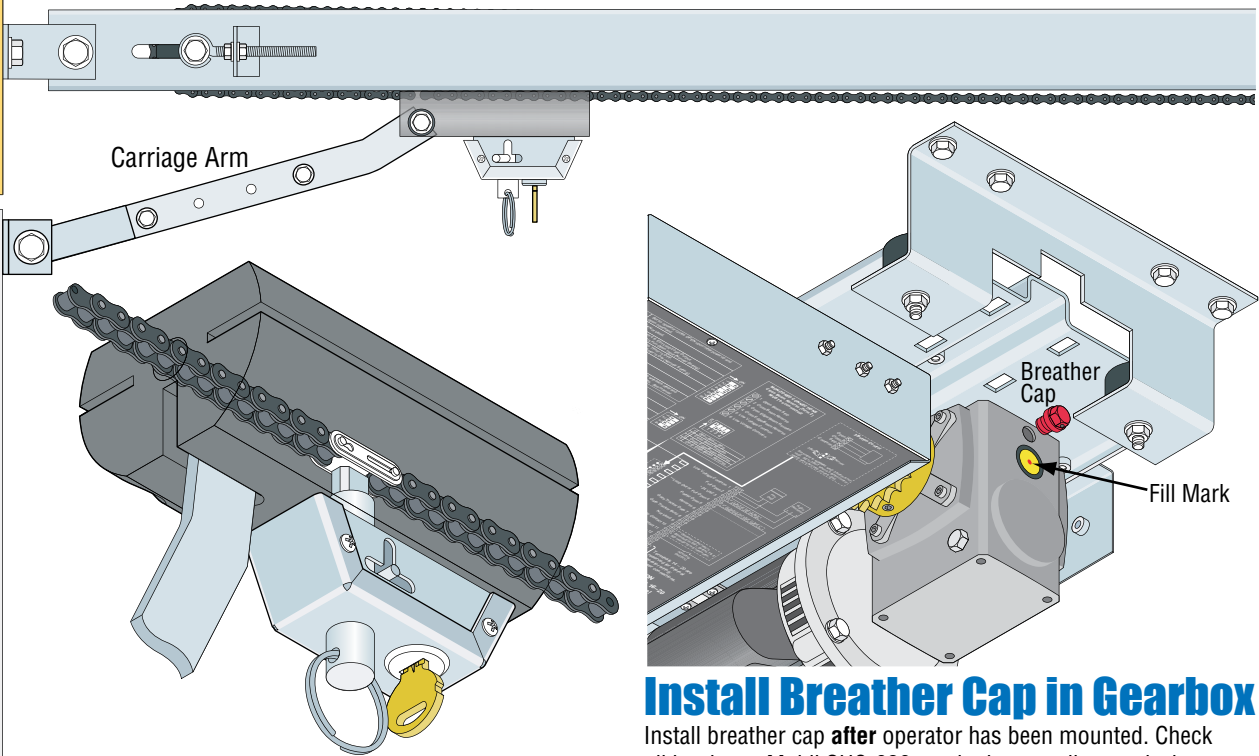

Install Breather Cap in Gearbox

Install breather cap **after** operator has been mounted. Check oil level, use Mobil SHC-629 synthetic gear oil or equivalent.

IMPORTANT: Gearbox should be filled to fill mark only. **Do not overfill.**

IMPORTANT: The carriage assembly's spring loaded chain catch will only lock into place in the double master chain link.

Final Chain Adjustment

Check that the chain is not rubbing on the steel rail separators. Final tension adjustment might be needed.

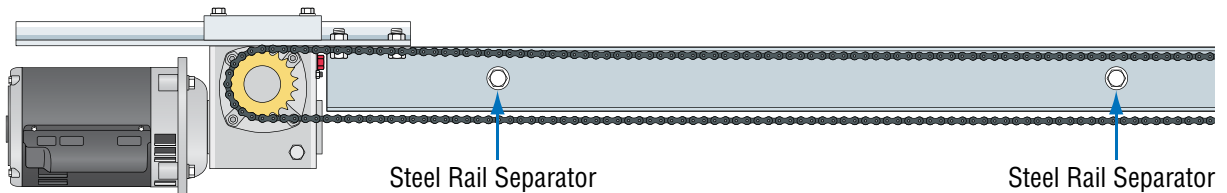

Installation of Warning Signs

This Operator is shipped with two warning signs. The purpose of the warning sign is to alert uninformed persons, and to remind persons familiar with the gate/door system, that a possible hazard exists so that appropriate action can be taken to avoid the hazard or to reduce exposure to the hazard. See page 2 for suggested mounting positions of signs.

- Permanently install the supplied warning signs in locations so that the signs are visible by persons on both sides of the gate/door.
- Use appropriate hardware such as wood or sheet metal screws (not supplied) to install the warning signs.



1.8 External Entrapment Protection Installation

External Entrapment Protection Devices:

In addition to the inherent reversing sensor system, this operator has a 6-pin UL 325 terminal for the connection of **MONITORED photo sensors**-Type B1 and/or **MONITORED reversing edges**-Type B2 entrapment protection required by UL 325 standards. **At least ONE external entrapment protection MONITORED device MUST be installed or the operator will NOT function.** Install these devices where the risk of entrapment or a safety hazard exists while the gate/door is moving. Specific installations will vary, see page 2 for more information.

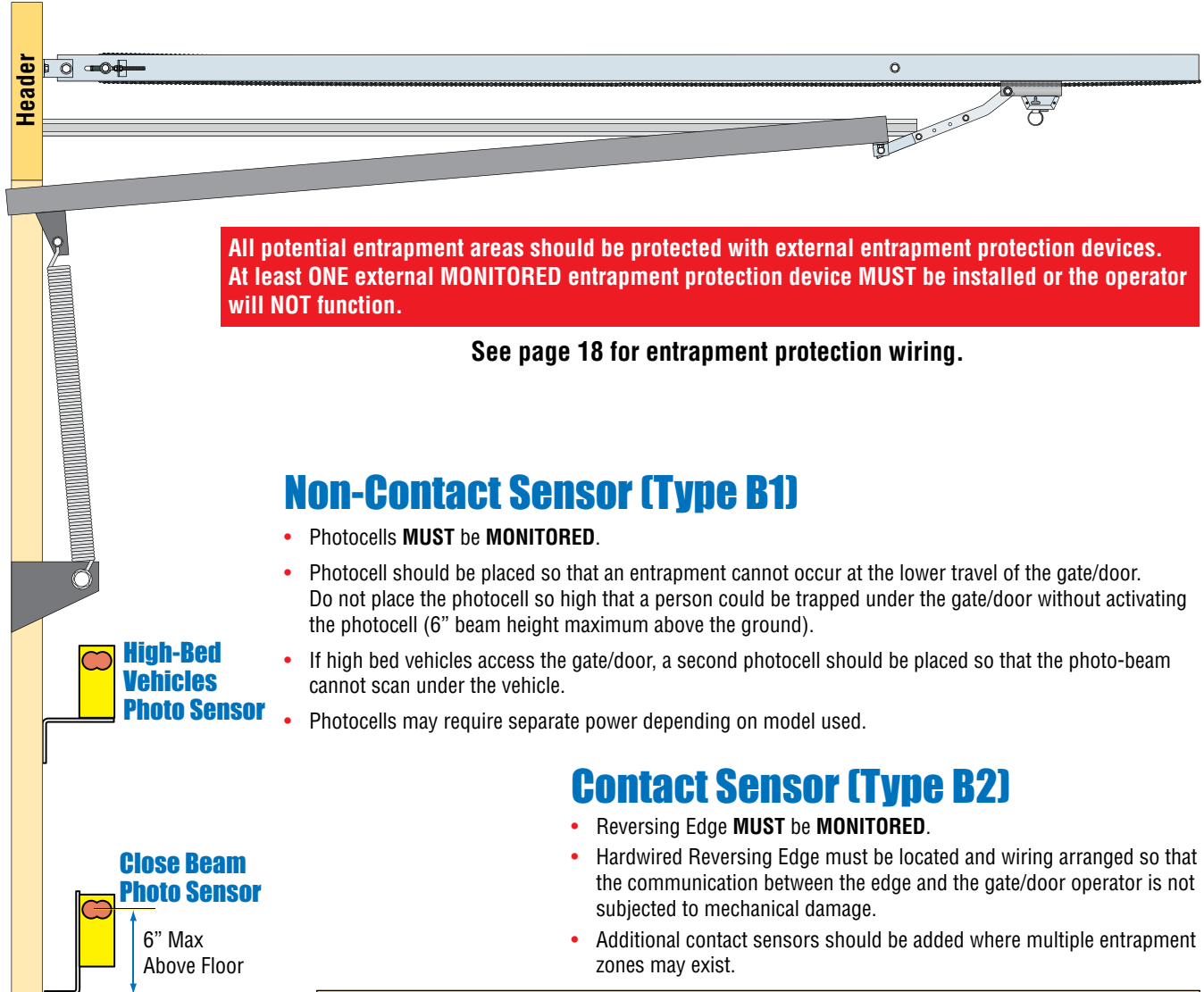

Non-Contact Sensor (Type B1)

- Photocells **MUST** be **MONITORED**.
- Photocell should be placed so that an entrapment cannot occur at the lower travel of the gate/door. Do not place the photocell so high that a person could be trapped under the gate/door without activating the photocell (6" beam height maximum above the ground).
- If high bed vehicles access the gate/door, a second photocell should be placed so that the photo-beam cannot scan under the vehicle.
- Photocells may require separate power depending on model used.

Contact Sensor (Type B2)

- Reversing Edge **MUST** be **MONITORED**.
- Hardwired Reversing Edge must be located and wiring arranged so that the communication between the edge and the gate/door operator is not subjected to mechanical damage.
- Additional contact sensors should be added where multiple entrapment zones may exist.

CLOSE Beam: Obstructed close-direction photo beam will **REVERSE** the gate/door **during the close-direction only**. Gate/door will close when the obstructed photo beam has been cleared and the close-timer times out.

CLOSING Reversing Edge: Obstructed close-direction reversing edge will **Reverse** the gate/door **back to the open position**. Another input is needed to close the gate/door.

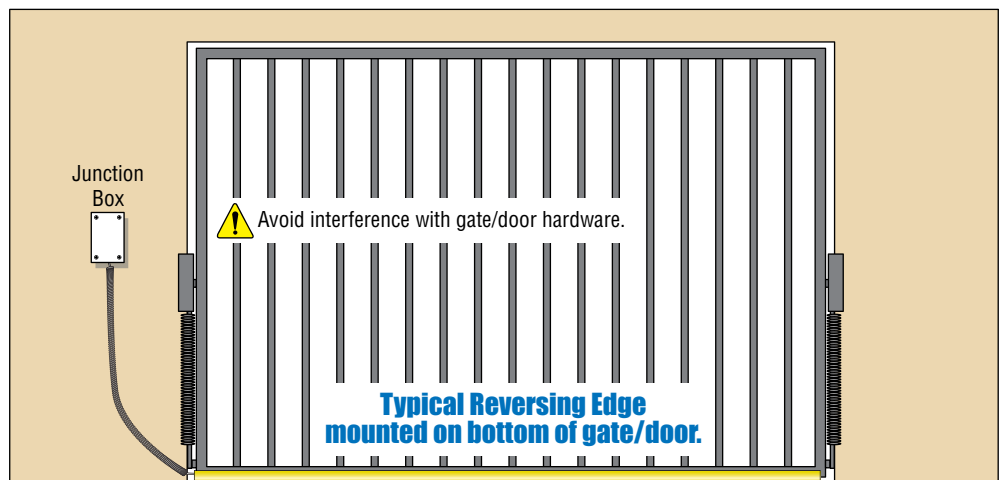

1.9 3-Button Control Station Installation

Permanently install the supplied warning sign next to the 3-Button control station so the sign is visible by a person using the control station.

! WARNING

! AVERTISSEMENT

Moving Gate Has the Potential of Inflicting Injury or Death – Do Not Start Gate Unless Path is Clear.

La Porte Mobile a le Potentiel D'infliger Des Blessures ou de la Mort - Ne Pas Démarrer la Porte à Moins que le Chemin ne Soit Clair.

P/N 2599-230

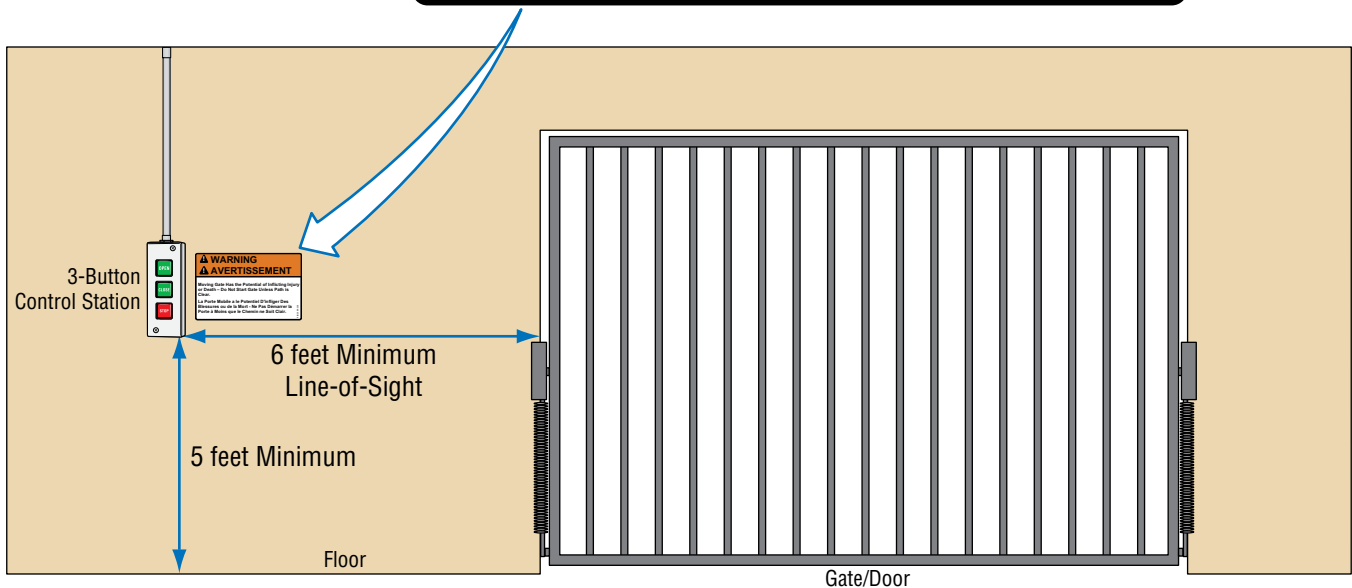

Install a standard **4-wire** 3-button control station mounted at least 5 ft above the floor and at least 6 ft from gate/door. It **MUST** be in the Line-of-Sight of the gate/door so a person operating the control station can see the moving gate/door area.

See page 17 to wiring control station to gate/door operator.

SECTION 2 - WIRING

Before attempting to connect any wiring to the operator, be sure that the circuit breaker in the electrical panel is in the OFF position. Permanent wiring must be installed to the operator as required by local electrical codes. It is recommended that a licensed electrical contractor perform this work.

Since building codes vary from city to city, we highly recommend that you check with your local building department prior to installing any permanent wiring to be sure that all wiring to the operator (both high and low voltage) complies with local code requirements.

THIS GATE/DOOR OPERATOR MUST BE PROPERLY GROUNDED!!

2.1 Conduit Requirements

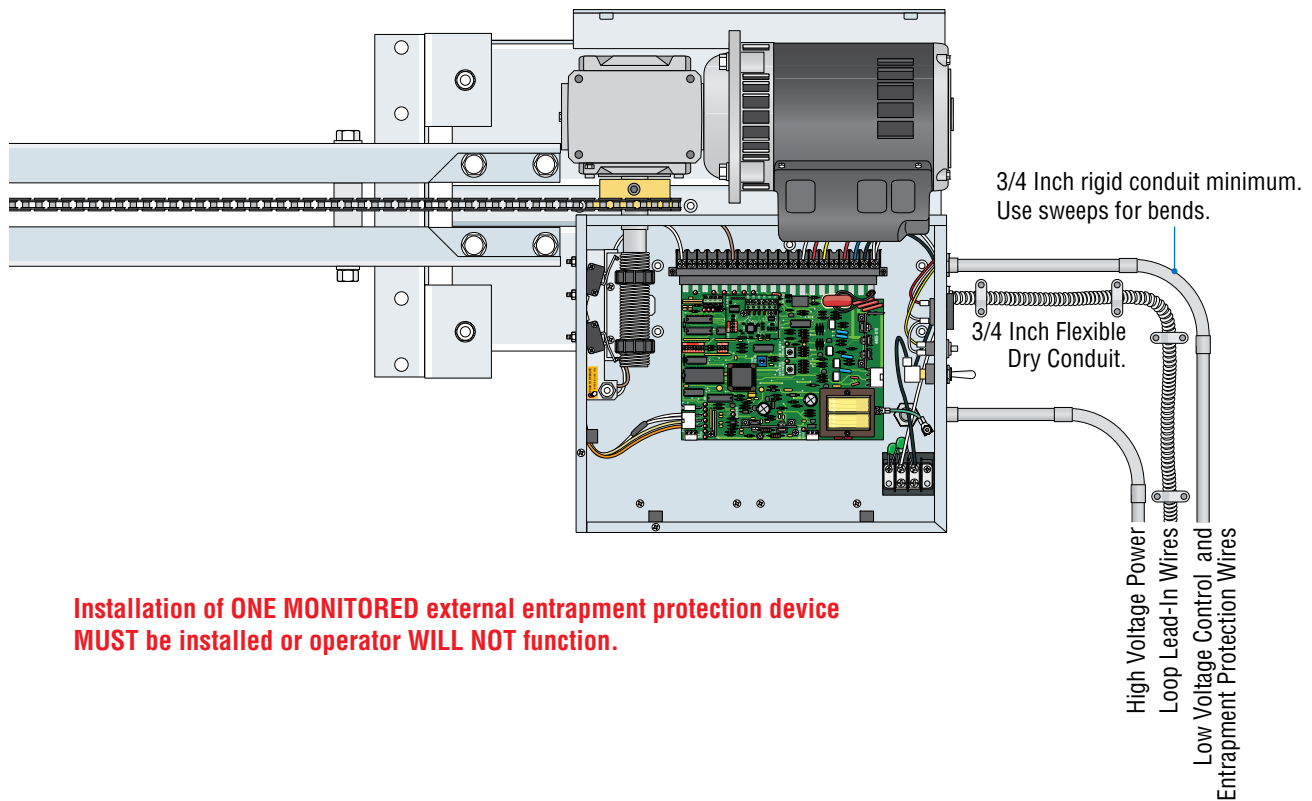

Installation of ONE MONITORED external entrapment protection device MUST be installed or operator WILL NOT function.

- The conduit requirements are for a typical overhead gate/door operator installation. **The conduit requirements for your application may vary from this depending on your specific needs.**
- Use only sweeps for conduit bends. Do not use 90° connectors as this will make wire pulls very difficult and can cause damage to wire insulation.
- We suggest that minimum 3/4-inch conduit be used.
- Be sure that all conduits are installed in accordance with local codes.

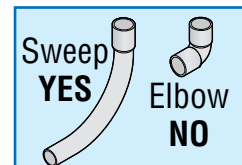

2.2 High Voltage Wire Run

The distance shown in the chart is measured in Feet from the operator to the power source. If power wiring is greater than the maximum distance shown, it is recommended that a service feeder be installed. When large gauge wire is used, a separate junction box must be installed for the operator connection. The wire table is based on stranded copper wire. Wire run calculations are based on a power source with a 3% voltage drop on the power line, plus an additional 10% reduction in distance to allow for other losses in the system.

This table illustrates the high voltage wire size and distance limitations.

Model Type	Voltage Required	Amps Required	Wire Size / Max Distance in Feet			
			12 AWG	10 AWG	8 AWG	6 AWG
1175	115	5.4	170	275	460	685

Never run high voltage and low voltage wires in the same conduit. Keep them in separate conduits.

2.3 High Voltage Terminal Connection

DO NOT cycle the operator without the OPEN and CLOSE limit nuts in their specific open and close positions. The limit nuts or the AC power switch are the only ways to STOP the operator once an open cycle has started. This could cause damage to the gate/door and/or operator if the gate/door opens too far!

Installation of ONE MONITORED external entrapment protection device MUST be installed or operator WILL NOT function.

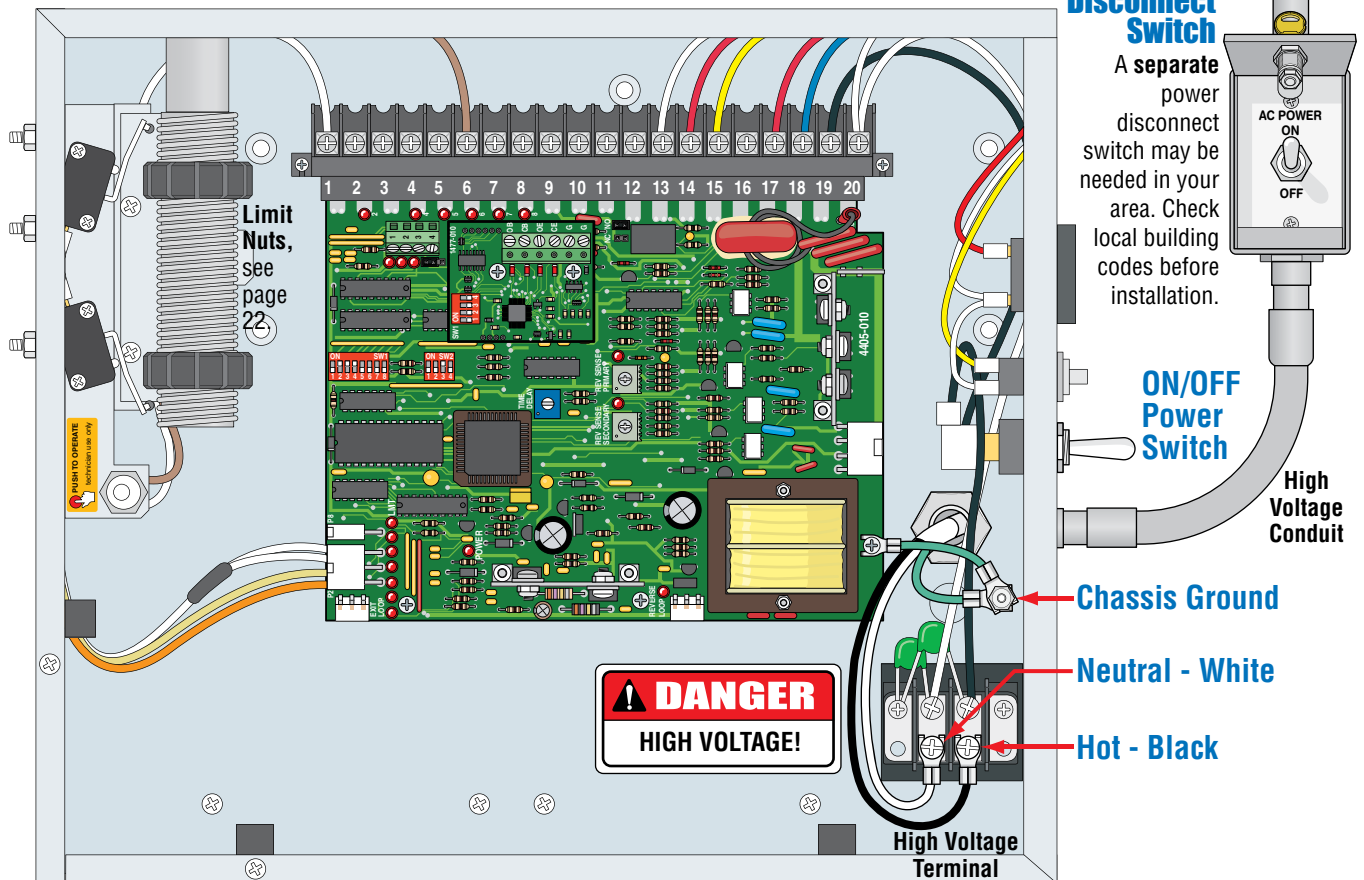

- Route incoming high voltage power through conduit and into the operator as shown.
- Be sure wiring is installed in accordance with local codes. Be sure to color code all wiring.
- Connect power wires as shown.
- It is recommended that a surge suppressor be installed on the high voltage power lines to help protect the operator and circuit board from surges and power fluctuations.

THIS GATE/DOOR OPERATOR MUST BE PROPERLY GROUNDED!!

2.4 Main Terminal Description

4-Pin Non-Removable Terminal

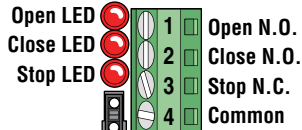

Jumper on **bottom** 2 pins when using 4-pin terminal.

Jumper on **top** 2 pins when **NOT** using 4-pin terminal.

- Use a standard **4-wire** 3-button control station mounted at least 5 ft above the floor and at least 6 ft from gate/door. See page 13 for info about installation. (DoorKing's **3-wire** 3-button control station **cannot** be used)

- When using a 3-button control station **AND** an interlock device together, #3 terminal (N.C.) must be wired in series.

- See page 17 for wiring.

4

- If SW 1, **switch 3** is **ON**, functions as a normal full open input (Normal setting).
- If SW 1, **switch 3** is **OFF**, input to terminal #4 becomes the output from the EXIT loop detector plugged into the EXIT loop port. (Used for specialized functions).

SW 1

20-Pin Main Terminal

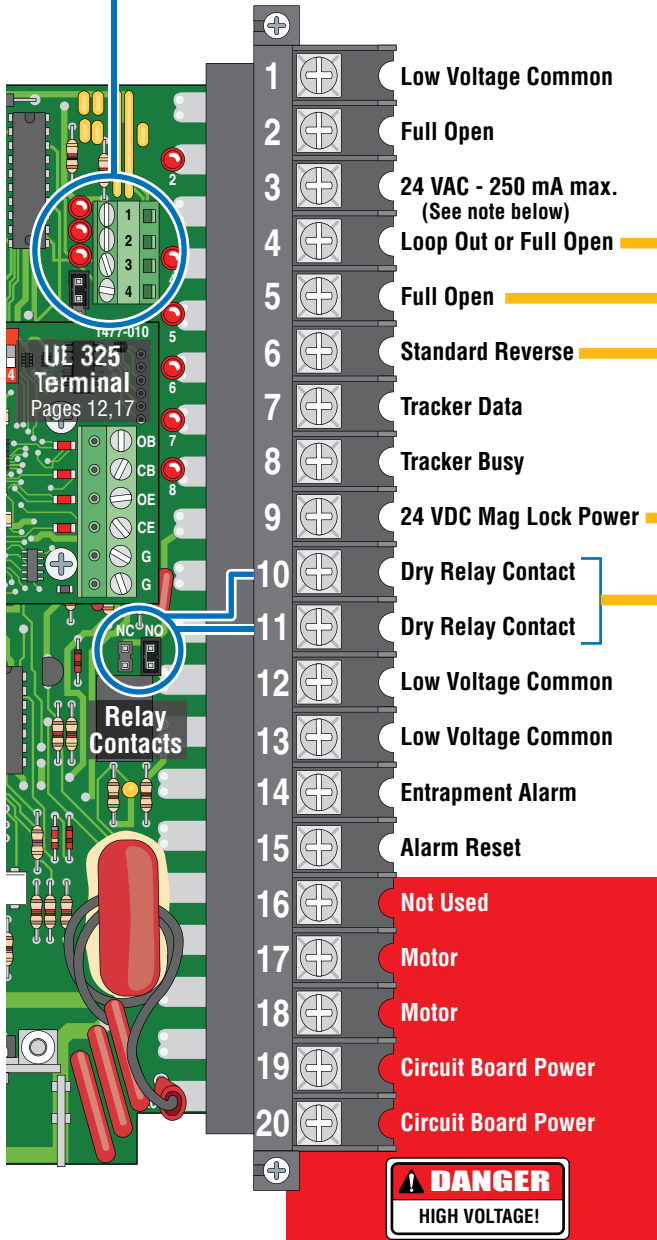

5

- When gate/door is closed, input will open gate/door.
- When gate/door is open and auto close timer SW 1, switch 4 is turned **ON**, input will re-set and hold timer.
- When gate/door is open and auto close timer SW 1, switch 4 is turned **OFF**, input will close gate/door.
- When gate/door is closing, input will reverse gate/door.

SW 1

6

This input **ONLY** functions when gate/door is **fully opened** or in the **closing cycle**.

- When gate/door is closing: SW 1, **switch 5** is **OFF**, an input to terminal #6 (e.g.: photo beam gets obstructed) will stop and **reverse** and the gate/door to the full open position. **Note:** If the auto-close timer is **ON**, when gate/door reaches the open position, timer **will not** close the gate/door. Another input command is needed to reset and close the gate/door (Normal Setting).
- SW 1, **switch 5 ON, NOT** used for gate/door operator.

SW 1

9

24-volt DC magnetic lock power is provided constantly except when the gate/door is **opening** or **open** (Normally Closed function). 1 Amp Max.

10/11

Operation of the circuit board dry relay contact is dependent on setting of SW 1, **switches 7 and 8**. **Relay contacts** can be set for Normally Open (NO) or Normally Closed (NC) operation.

Contact rating is **1 amp maximum** at 24-volts DC.

SW 1

Main Terminal #3 Note:
Exceeding 250 mA of power from this terminal may cause the circuit board transformer to overheat, causing intermittent problems.

2.5 Control Wiring

4-Pin Non-Removable Terminal

3-Pin With Jumper
Place jumper on bottom 2 pins when using 4-pin terminal.

3-Button Control Station
Use a standard 4-wire 3-button control station. DoorKing's 3-wire 3-button control station CANNOT be used.

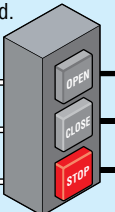

#1 Open N.O.
#2 Close N.O.
#3 Stop N.C.
#4 Com

Normally Closed Interlock Switch

Note: When using 3-button control station AND interlock switch together, #3 terminal (N.C.) must be wired in series.

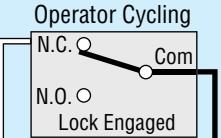

To #3 Stop N.C.
To #4 Com

Important: Controls intended for user activation must be located at least six (6) feet away from any moving part of the gate/door and where the user is prevented from reaching over, under, around or through the gate/door to operate the controls. Emergency access controls only accessible by authorized personnel (e.g., fire, police, EMS) may be placed at any location in the line-of-sight of the gate/door. See page 13 for a 3-Button control station installation and included warning label placement.

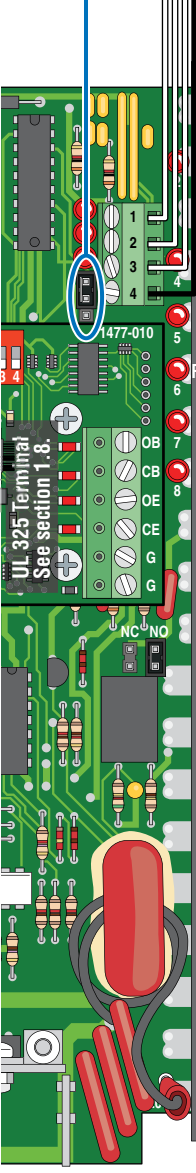

20-Pin Main Terminal

Main Terminal #3 Note:
Exceeding 250 mA of power from this terminal may cause the circuit board transformer to overheat, causing intermittent problems.

24 Volt
1 amp max.

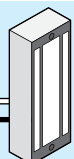

Magnetic Lock
Power (24-Volt DC) and logic output. Power is shut off .5 sec. prior to gate/door starting and remains off while gate/door is opening and in the open position.

#9 Normally Close



Terminal 5
Optional

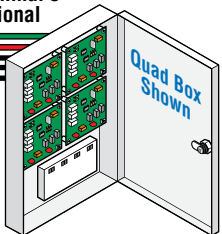

DKS Tracker - DoorKing Access Control System (Model 1833, 1835, 1837 or 1838) tracker system can be connected. This system can keep track of gate/door operator cycle count, shorted inputs, loop detector problems, any forced entry attempts, if the gate/door has struck anything during the open or close cycle, power interruptions, etc. For more detailed information refer to the Tracker Installation and Wiring Manual, DoorKing P/N 2358-065.

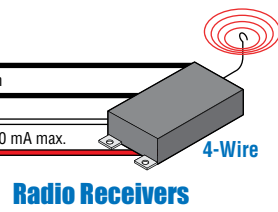

Radio Receivers

#4 - Safety Opening Device

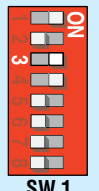
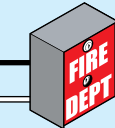

SW 1, switch 3 Must be ON.

#5 - Access Control Devices

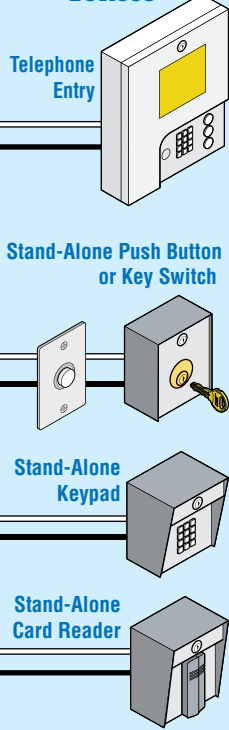

Note: All stand-alone and telephone entry devices must use a separate power source.



2.6 External Entrapment Protection Wiring

External Entrapment Protection Devices:

In addition to the inherent reversing sensor system, this operator has a 6-pin UL 325 terminal for the connection of **photo sensors**-Type B1 and/or **reversing edges**-Type B2 entrapment protection required by UL 325 standards. **At least ONE external entrapment protection MONITORED device MUST be installed or the operator will NOT function.** Install these devices where the risk of entrapment or a safety hazard exists while the gate/door is moving. Specific installations will vary.

- Use only UL listed (or equivalent) MONITORED sensors.
- Sensors shall be located where the risk of entrapment or obstruction exists, such as the perimeter reachable by a moving gate/door or barrier. Additional sensors should be added for additional protection where entrapment zones exist. Actual placement of sensors is dependent on the installation requirements.
- Disconnect power to gate/door operator before installing the sensors.

Non-Contact Sensor (Type B1)

- Photo-cell should be placed so that an entrapment cannot occur at the lower travel of the gate/door. Do not place the photocell so high that a person could be trapped under the gate/door without activating the photocell.
- If high bed vehicles access the gate/door, a second photocell should be placed so that the photo-beam cannot scan under the vehicle.
- Photocells may require separate power depending on model used.

All potential entrapment areas **MUST** be protected with an external entrapment protection device. See page 12. **At least ONE external entrapment protection device MUST be installed or the operator will NOT function.**

Entrapment Protection Board

ONLY connect monitored devices.

The 6-pin terminal can be unplugged from circuit board for easy wire connections.

LED Lights:

LED OFF: appropriate device is connected.

LED ON: device has been activated.

Flashing LED: device NOT connected.

Not appropriate device.

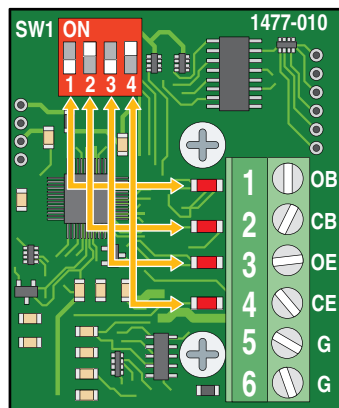

DIP-Switches MUST be turned ON for each connected device.

Monitored Device Note: Only 1 monitored Device can be connected to each input. An **OPTIONAL** Expansion Board (sold separately) will allow connection for additional devices.

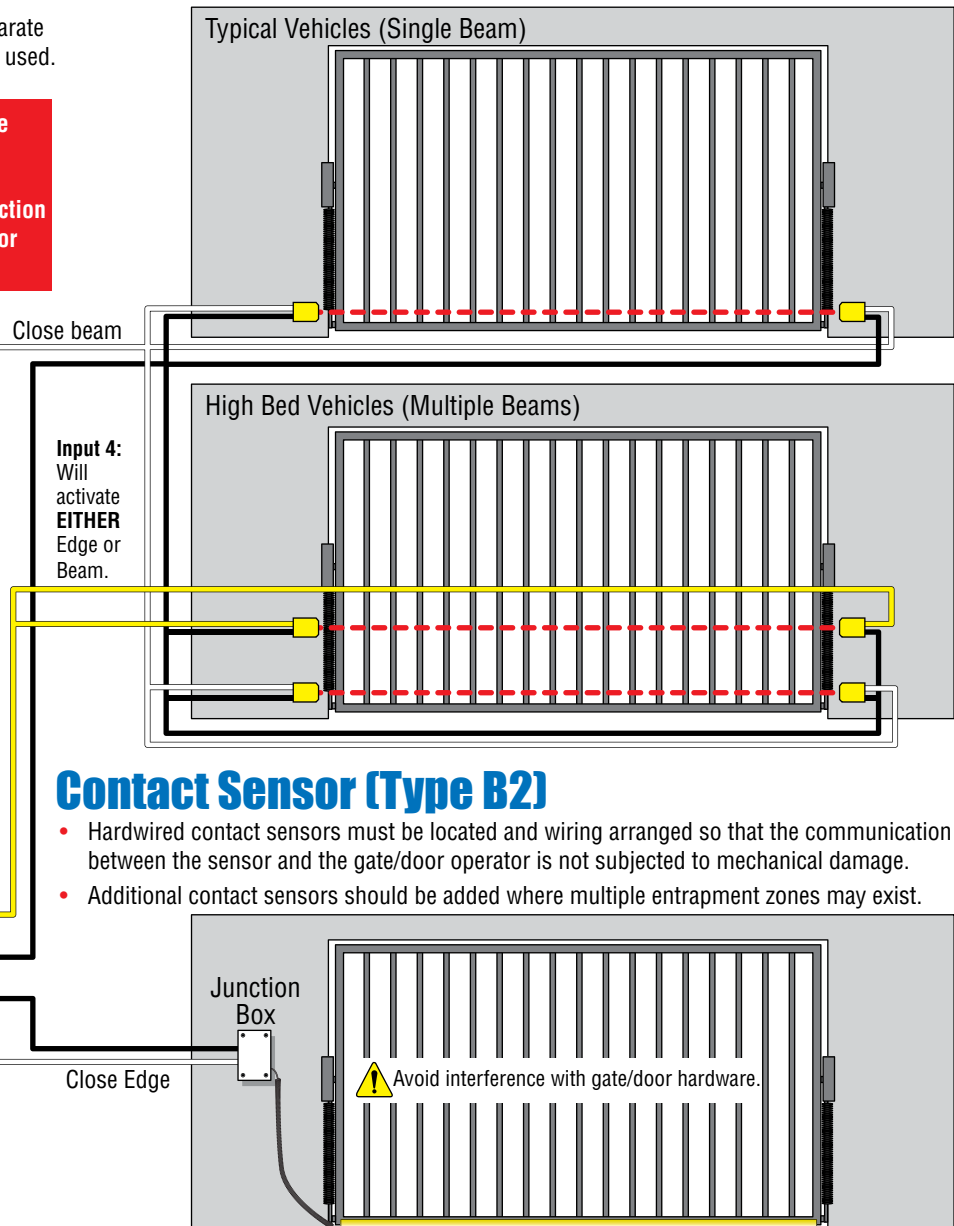

Contact Sensor (Type B2)

- Hardwired contact sensors must be located and wiring arranged so that the communication between the sensor and the gate/door operator is not subjected to mechanical damage.
- Additional contact sensors should be added where multiple entrapment zones may exist.

2.7 Loop Detector Wiring

Loop detectors **must** be installed to prevent the gate/door from accidentally closing on vehicles that may be in the path of the gate/door.

- Install 9410 Single Channel or 9409 Dual Channel DoorKing plug-in loop detectors (Sold separately).
- If using external loop detectors, use only UL listed (or equivalent) detectors. Use a separate power supply for external loop detectors. Inputs to circuit board are Normally Open (NO).
- Disconnect power to operator before installing any loop detectors.

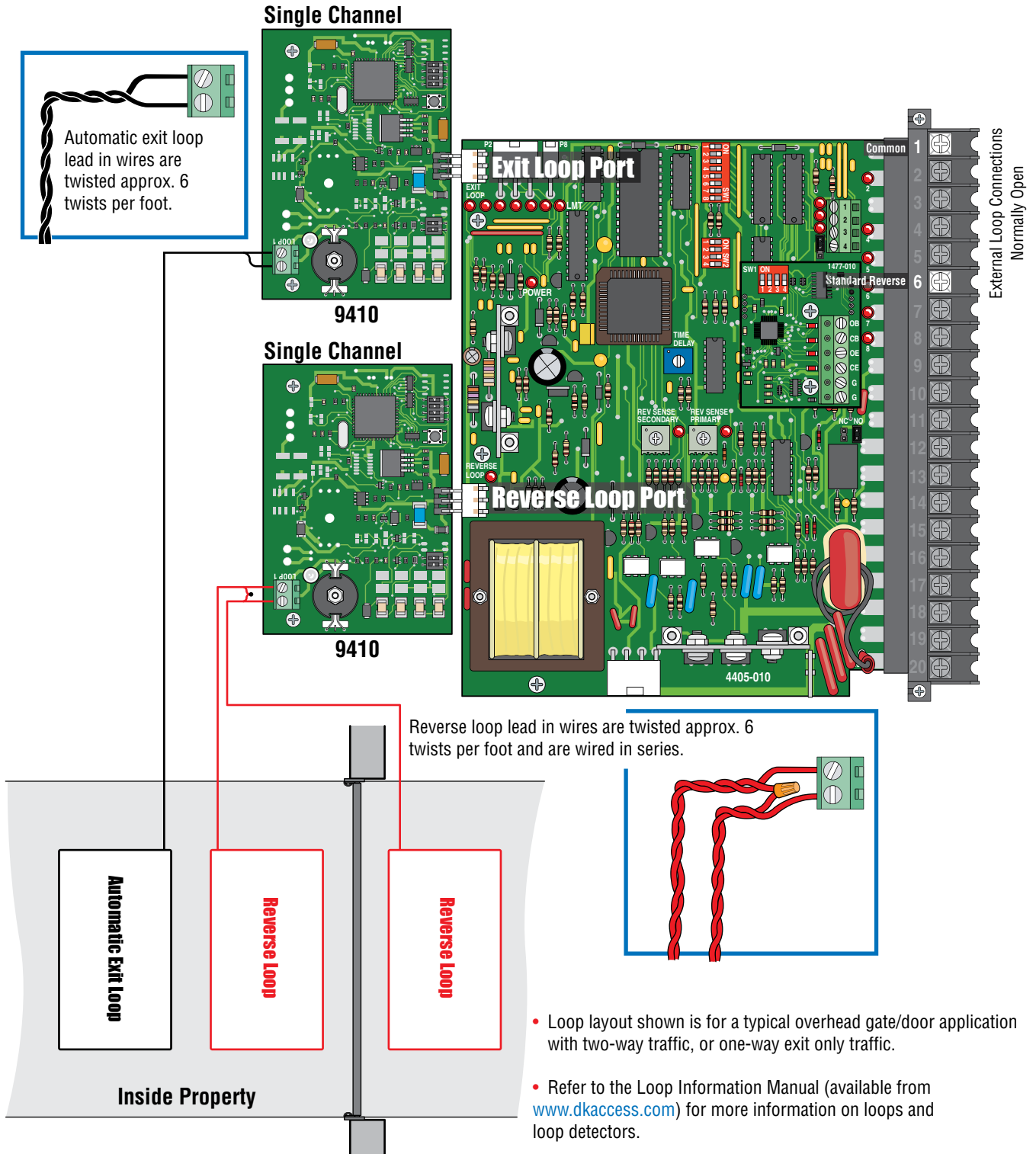

SECTION 3 - ADJUSTMENTS

The switch settings and adjustments in this chapter should be made after your installation and wiring to the operator is complete. **Whenever any of the programming switches on the circuit board are changed, power must be shut-off, and then turned back on for the new setting to take effect.**

3.1 4405 Circuit Board Descriptions and Adjustments

DIP-Switches

Set the DIP-switches on the circuit board to the desired setting. See switch-settings on next 2 pages.

SW 1
SW 2

Auto-Close Timer

Auto-close timer (when turned on) SW 1, switch 4.

SW 1

Time Delay:

Adjust from 1 second (full counter-clockwise) to approximately 23 seconds (full clockwise).

How LEDs Function

Illuminated LEDs Indicates that low voltage power is being applied to the circuit board.

Input LEDs should be OFF and will only illuminate when the input is activated.

Limit LEDs will only illuminate when the respective limit sensor has been activated.

Loop LEDs will only illuminate when a reverse or exit loop is activated (Vehicle passing over a loop).

Limit Switch Plug P2
See page 22

4-Pin Non-Removable Terminal
See pages 16 and 17.

6-Pin UL 325 Removable Terminal and 4 DIP-Switches
See pages 12,18.

Dry Relay Contact
Operation of the circuit board dry relay contact is dependent on setting of SW 1, switches 7 and 8. See switch-settings on next page.

Terminals 10-11 can be set for Normally Open (NO) or Normally Closed (NC) operation by placing the relay shorting bar on the N.O. or N.C. pins respectively.

Inherent Reverse Sensor
Adjust reversing sensitivity for the open AND close direction of the operator. Secondary adjustment is NOT used. See page 23.

Plug-In Loop Detectors (Sold separately)
EXIT Loop Terminal
REVERSE Loop Terminal
See page 19.

Loop LEDs
Power LED
TIME DELAY
REV SENSE SECONDARY
REV SENSE PRIMARY
NC-NO
Input LEDs
Chassis Ground
Plug Not used

3.2 DIP-Switch Descriptions and Functions

The two DIP-switches located on the circuit board are used to program the operator to operate in various modes and to turn on or off various operating features. Whenever a switch setting is changed, power to the operator must be turned OFF and then turned back on for the new setting to take affect. Check and review ALL switch settings prior to applying power to the operator.

SW 1 (Top 8 Switches)			
Switch	Function	Setting	Description
1	Opening Direction	MUST be in ON Position.	
2	OFF	Leave in OFF Position.	
3	Exit Loop Port Output	OFF	The output wired to terminal #4 becomes the output from the exit loop detector plugged into the EXIT Loop port.
	Full Open Input	ON	Normal Setting. Terminal #4 is a normal full open input.
4	Auto-Close Timer	OFF	Auto-close timer is OFF. Manual input required to close gate/door.
		ON	Normal Setting. Auto-close timer is ON. Adjustable from 1-23 seconds.
5	OFF	Leave in OFF Position.	
6	OFF	Leave in OFF Position.	
7 and 8	Circuit Board Relay	7-OFF 8-OFF	Normal Setting. Relay activates when gate/door is at open limit.
		7-OFF 8-ON	Relay activates when gate/door is not closed.
		7-ON 8-OFF	Relay activates when gate/door is opening and open.
		7-ON 8-ON	Relay activates during opening and closing cycle.

Switch 1 **Must OPEN** upon initial AC power up and open command. Set to **ON** Position.

Switch 2 Leave in **OFF** position.

Switch 3 Determines that a device wired to terminal #4 is a normal full open command **OR** terminal #4 becomes the output from the exit loop detector that is plugged into the EXIT Loop port in the circuit board (Used for specialized functions).

Switch 4 Turns the auto-close timer on or off. Maximum time that the close timer can be set for is approximately 23 seconds.

Switch 5 Leave in **OFF** position.

Switch 6 Leave in **OFF** position.

Switches 7-8 These work in conjunction with each other and determine when the relay on the board will be activated. This relay can be used as a switch for various functions such as illuminating a warning light when the gate/door is moving, or turning on a green light when the gate/door is full open.

SW 2 (Bottom 4 Switches)			
Switch	Function	Setting	Description
1	OFF	Leave in OFF Position.	
2	Magnetic lock	OFF	Normal Setting. Magnetic lock is not used.
		ON	Magnetic lock is used and connected to terminals 9 and 13. See page 17 for wiring.
3	ON	Switch 3 MUST be in ON Position.	
4	OFF	Switch 4 MUST be turned OFF for Model 1175 operator.	

Switch 1 Leave in **OFF** position.

Switch 2 If a magnetic lock is not used with the gate/door operator, leave this switch in the OFF position. Turn this switch ON if a magnetic lock is used and connected to terminals 9 and 13. This applies magnetic lock power and logic to these terminals (NC).

Switch 3 **MUST** be in **ON** position.

Switch 4 **MUST** be turned **OFF** for the Model 1175.

3.3 Limit Switch Adjustments

Basic DIP Settings

- Start-up direction **MUST** be **ON**. SW 1, switch 1.
- SW 1, switch 3 should be **ON**.
- Auto close timer (when turned on) SW 1, switch 4.
- SW 2, switch 3 **MUST** be **ON**.
- SW 2, switch 4 **MUST** be **OFF**.

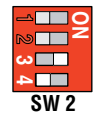
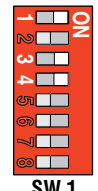

Time Delay

Setting Auto Close Timer

Adjust from 1 second (full counter clockwise) to approximately 23 seconds (full clockwise).

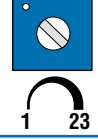

- Turn power off.
- Push and hold locking plate tab.
- Adjust limit nuts at full open and full close gate/door positions.
- Release locking plate tab to secure limit nuts.
- Turn power on. Cycle gate/door and check positions.
- Re-adjust if necessary.

Installation of ONE MONITORED external entrapment protection device MUST be installed or operator WILL NOT function.

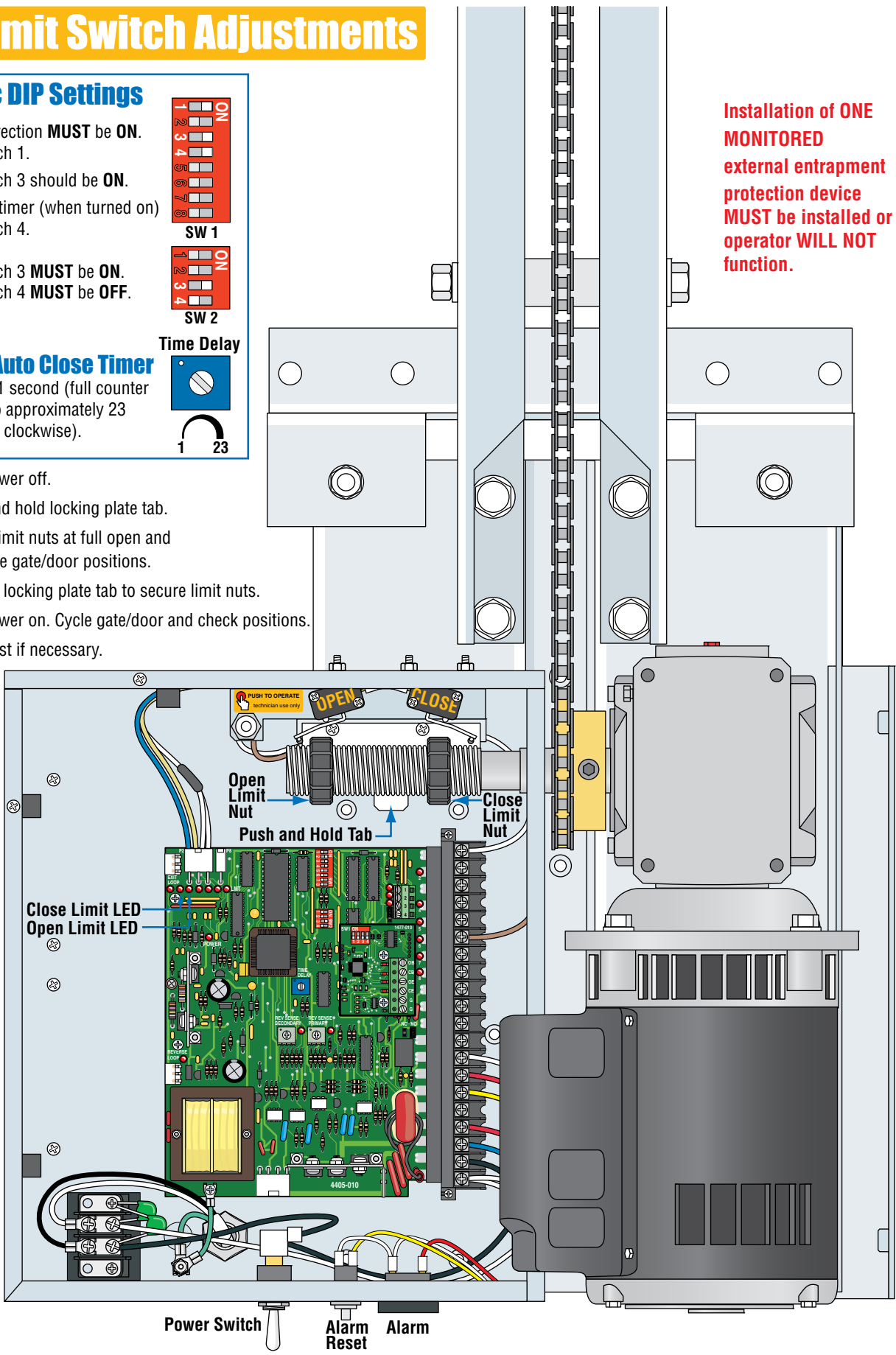

3.4 Inherent Reverse Sensor Adjustment

This vehicular gate/door operator is equipped with an inherent (Type A) entrapment sensing system. This system will sense an obstruction in either the opening or closing gate/door cycles and will cause the gate/door to reverse direction should an obstruction be encountered. For this system to function correctly, the gate/door must be properly installed and work freely in both directions.

1 After the limit nuts have been adjusted, activate the gate/door operator by pushing “Push to Operate” button.

2 While the gate/door is **OPENING**, slowly rotate the **PRIMARY** reverse sensor clockwise until the gate/door stops and the LED will light up, then rotate the sensor 1/8 turn counter-clockwise. After the gate/door has stopped, push “Push to Operate” button again to continue the open cycle of the gate/door. Auto close timer (If ON, SW1, switch 4) will then close the gate/door, completing the gate/door’s open/close cycle.

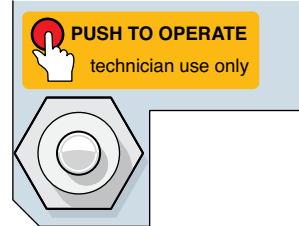

Note: Clockwise INCREASES the reverse sensitivity. Counter-clockwise DECREASES the reverse sensitivity.

3 While the gate/door is **CLOSING**, slowly rotate the **PRIMARY** reverse sensor clockwise until the gate/door stops and the LED will light up, then rotate the sensor 1/8 turn counter-clockwise. The gate/door will automatically reverse direction and open. Auto close timer (If ON, SW1, switch 4) will then close the gate/door, completing the gate/door’s open/close cycle.

Note: You may have to repeat these steps a few times to get the gate/door to completely cycle open and closed.

Test Reverse Sensors

1 Place an immobile object along the path of the gate/door so that the gate/door strikes it while **opening**. Gate/door must **STOP!** Re-adjust **Open** sensor if necessary.

2 Place an immobile object along the path of the gate/door so that the gate/door strikes it while **closing**. Gate/door must **REVERSE** direction and open! Re-adjust **Close** sensor if necessary.

Note: If alarm sounds while performing these tests, press alarm reset button to shut off alarm.

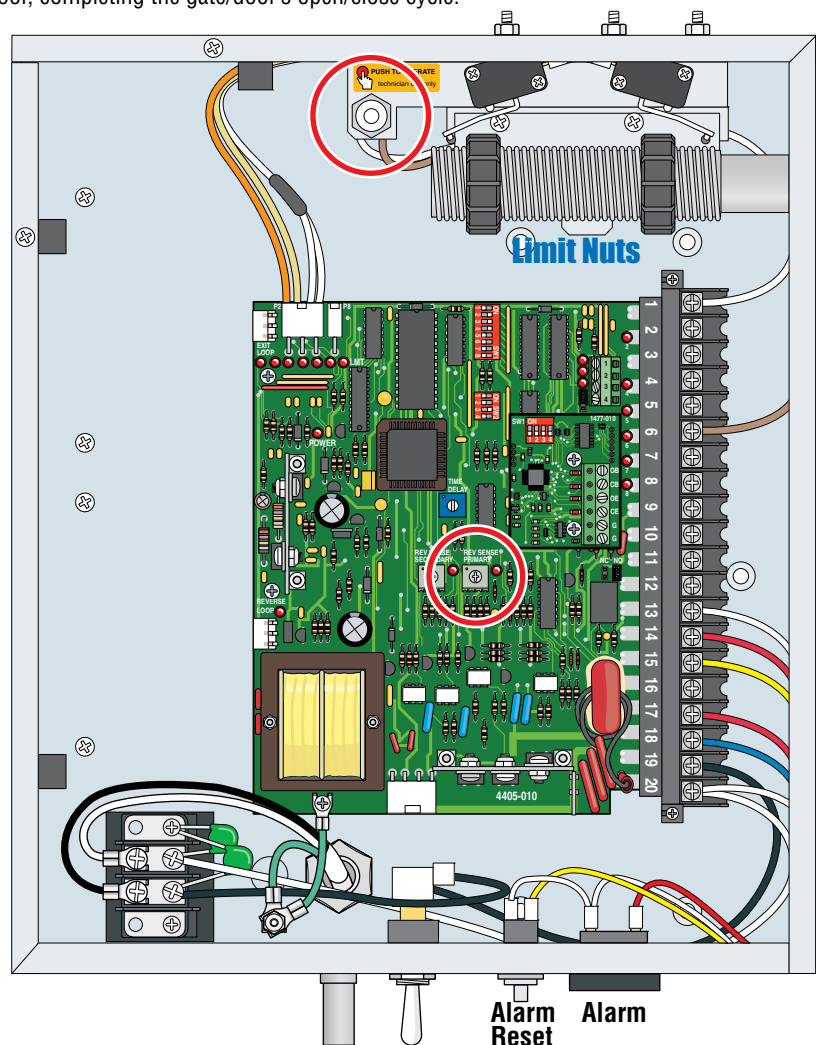

SECTION 4 - OPERATING INSTRUCTIONS

IMPORTANT SAFETY INSTRUCTIONS

WARNING - To reduce the risk of injury or death:

1. READ AND FOLLOW ALL INSTRUCTIONS.
2. Never let children operate or play with gate/door controls. Keep the remote control away from children.
3. Always keep people and objects away from gate/door. **NO ONE SHOULD CROSS THE PATH OF THE MOVING GATE/DOOR.**
4. Test the operator monthly. The gate/door **MUST** reverse on contact with a rigid object or stop or reverse when an object activates the non-contact sensors. After adjusting the force or the limit of travel, retest the gate/door operator. Failure to adjust and retest the gate/door operator properly can increase the risk of injury or death.
5. Use the emergency release only when the gate/door is not moving and power has been shut-off.
6. **KEEP GATE/DOORS PROPERLY MAINTAINED.** Read the owner's manual. Have a qualified service person make repairs to gate/door hardware.
7. The entrance is for vehicles only. Pedestrians must use separate entrance.
8. **SAVE THESE INSTRUCTIONS.**

4.1 Power Switch and Alarm Reset Switch

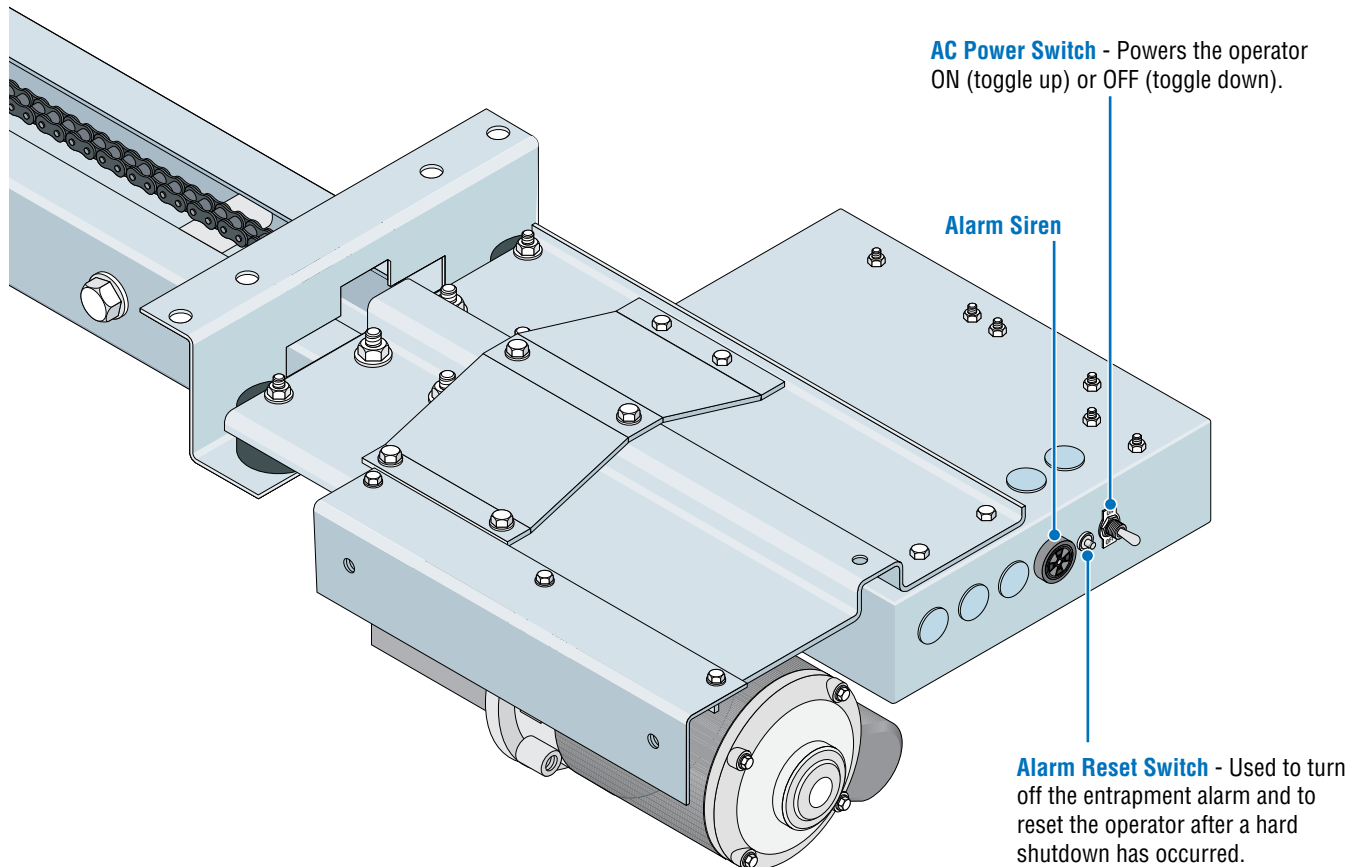

4.2 Shutdown Conditions

Under various entrapment conditions the operator will assume either a **soft** or **hard (alarm)** shutdown. To determine what type of reset action is required, you will need to understand how the different entrapment conditions affect the gate/door operator.

Soft Shutdown

This occurs in various situations where the inherent or entrapment protection devices have been activated. In a soft shutdown condition, the operator **will not** respond to any input that was present when the entrapment protection device sensed an obstruction. If the gate/door stops at the open position, the operator will not respond to the automatic close timer.

- **Example 1** - A time clock keys the gate/door open in the morning and an entrapment protection device senses an obstruction prior to the gate/door reaching the full open position. If the entrapment is sensed by the inherent system, the gate/door will reverse and run back to the closed position. The time clock input is still present, but the gate/door will not re-open.

Note: In some systems, the time clock input comes from the telephone entry system relay. This same relay may also provide open commands for a card reader, MicroPLUS transmitters and the visitor telephone entry. If so, these devices will also be disabled in a soft shutdown condition.

- **Example 2** - If the gate/door is closing and an entrapment protection device is activated, the gate/door will either stop or reverse and run back to the open position, depending upon if the external or inherent device was activated. The automatic close timer will not close the gate/door.
- **Example 3** - Vehicle arrives at open loop and gate/door runs towards the open position. The inherent entrapment protection is activated. The gate/door reverses and runs back to the closed position. If the vehicle is still present at the open loop a soft shutdown condition does not occur. The loop input provides an immediate reset of the operator and the gate/door will again run to the open position.

Resetting a Soft Shutdown

In some conditions, a soft shutdown will reset as soon as the entrapment condition clears. For example, if a non-contact sensor (photo sensor) is sensing an obstruction, the operator will stop the gate/door and assume a soft shutdown condition. When the photocell clears, the operator will return to normal operation.

When the operator is in a soft shutdown, activation of any "intended input" will reset the operator. An "intended input" includes any command, any standard safety input and any loop input. Activating any of these inputs will reset the gate/door. At that point the gate/door will return to normal operation. If the gate/door is open, the automatic close timer will then time out and close the gate/door.

Hard Shutdown (Alarm Activated)

A hard shutdown condition occurs when the inherent entrapment protection system has sensed **TWO** consecutive obstructions before the **closing** gate/door reaches the closed position.

- **Example** - The gate/door is closing and the inherent entrapment protection system senses an obstruction and causes the gate/door to reverse direction. As the gate/door begins to run in the open direction, a second obstruction is sensed prior to the gate/door reaching the full open position. Once the second obstruction has been sensed, the operator will stop, the audio alarm will be activated and all standard inputs are shut down (including open commands, safety commands, loop inputs, etc.).

The audio alarm will sound for five minutes, or until the operator's reset button is pushed. After (5) five minutes the alarm will "chirp every 5 sec." and the hard shutdown condition will remain in affect until the reset button is pushed.

- After 5 minutes, the audio alarm will "chirp" every 5 seconds. This indicates that the operator is in a hard shutdown condition and the reset switch must be activated to reset the operator and silence the alarm.

Continued on the next page

Resetting a Hard Shutdown

When the operator is in a hard shutdown condition (audio alarm activated or audio alarm “chirps” every 5 seconds), the only way to reset the gate/door operator and return it to normal operation is to activate the alarm reset input (auxiliary terminals 2 and 3). An alarm-reset switch can be mounted external of the gate/door operator provided that it is installed in the line of sight of the gate/door and gate/door operator.

- Before resetting a hard shutdown, determine why the shutdown occurred. Inspect the gate/door for any obstructions along its path that could have activated the inherent entrapment sensing system. Inspect the gate/door and gate/door hardware.

NOTE: DoorKing operators have a built-in alarm reset push button mounted on the operator above the power ON-OFF toggle switch. Activating this button will return the gate/door operator to normal operation, **but will not activate the gate/door operator.**

Once the gate/door has been reset, an open or close command is needed to start the gate/door operator. Most activating commands will cause the gate/door operator to cycle to the open position. This includes activation of a key switch or open command and activation of the automatic exit loop. Activation of a close command will run the gate/door to the closed position.

4.3 Manual Gate/Door Operation

This operator is equipped with a manual release system that will allow the gate/door to be pushed open in the event of a power outage or equipment failure.

This gate/door operator CAN NOT be manually forced open in the event of a power failure without FIRST manually releasing the gate/door! (See next page)

Never attempt to manually push open any gate/door with an operator attached to it until you have verified that power to the operator has been shut-off.

Emergency Vehicle Access Conditions

The automatic vehicular gate/door system must be designed to allow access to emergency vehicles under different operating conditions.



1. During normal powered operation, emergency vehicles access the gate/door by use of the **Emergency Vehicle Access Device** installed on your gate/door system. The type of device that is used in your community is dependent on your city codes. These devices may include (but are not limited to) Fire Department lock boxes, Click-2-Enter radio receivers, strobe light sensors, siren sensors, etc.

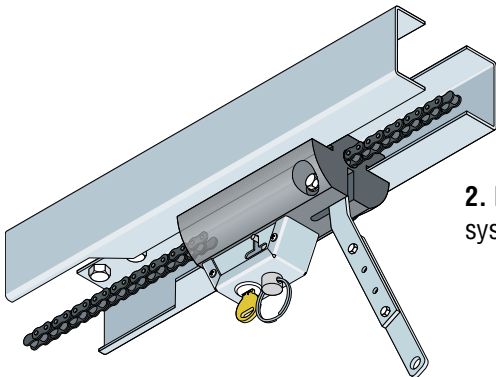

2. In the event of a primary (AC) power failure, the system must have a release system to allow the gate/door to be **Manually Operated** (See next page).

Manual Release

Never attempt to manually open any gate/door with an operator attached to it until you have verified that power to the operator has been shut-off.

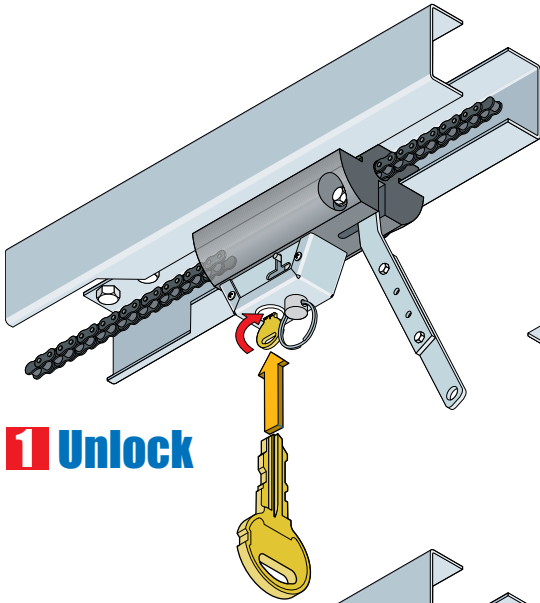

1 Unlock

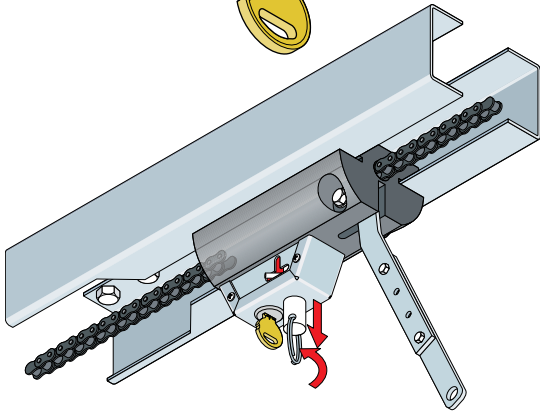
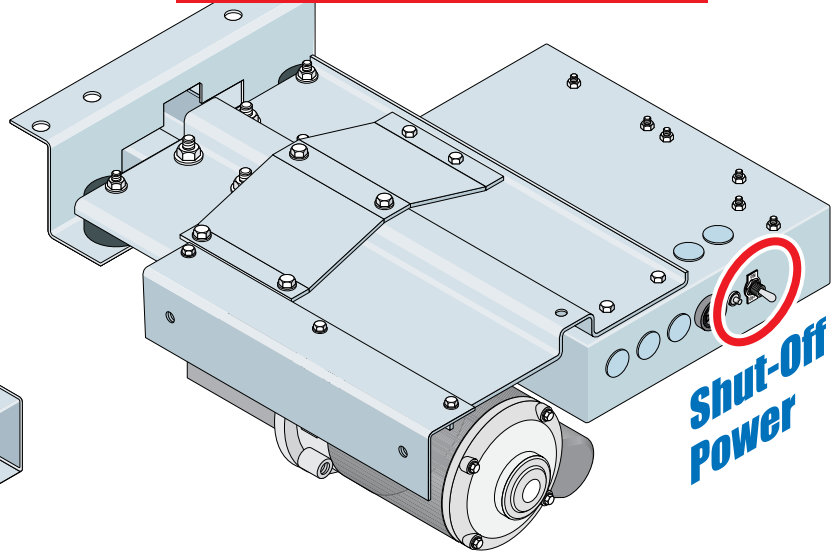

2 Pull Ring Down and Turn

Gate/door can now be manually operated

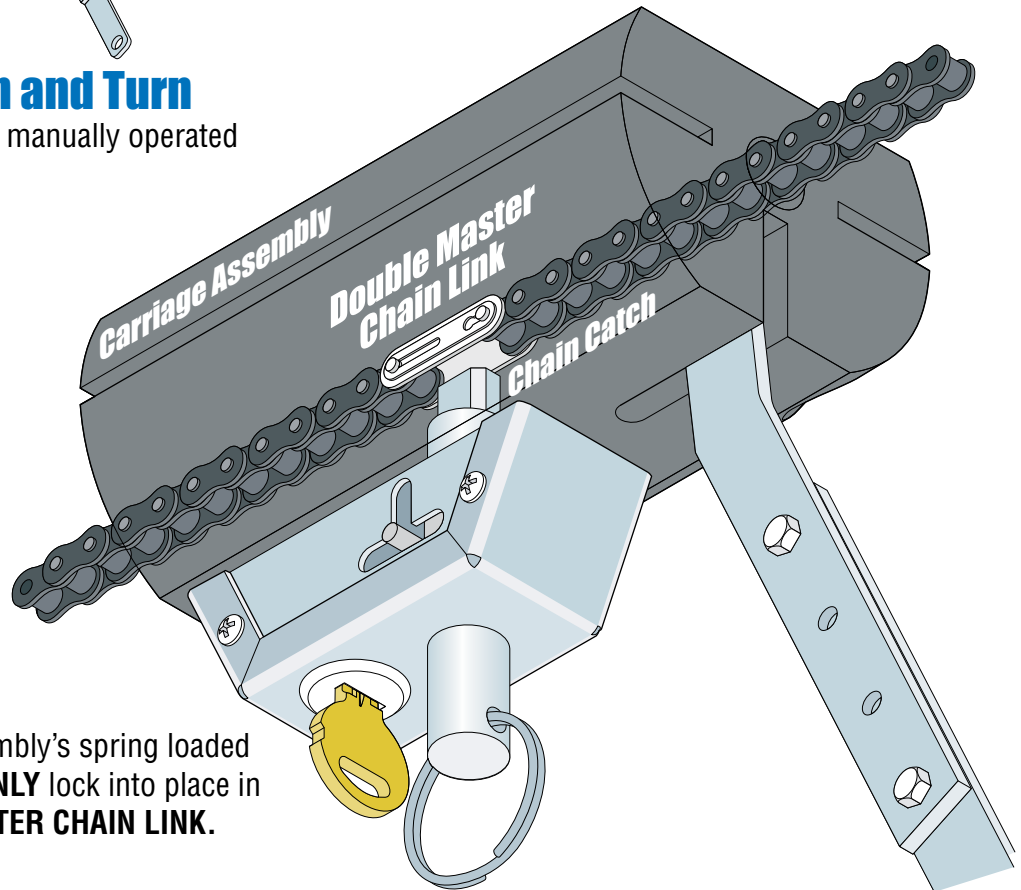

IMPORTANT:

The carriage assembly's spring loaded chain catch will **ONLY** lock into place in the **DOUBLE MASTER CHAIN LINK**.

SECTION 5 - TECHNICAL INSTRUCTIONS

Inspection and service of this gate/door operator by a qualified technician should be performed anytime a malfunction is observed or suspected. High cycle usage may require more frequent service checks.

5.1 Maintenance

When servicing the gate/door operator, always check any external reversing devices (loops, photocells, etc.) for proper operation. If external reversing devices cannot be made operable, do not place this operator in service until the malfunction can be identified and corrected.

Always check the inherent reversing system when performing any maintenance. If the inherent reversing system cannot be made operable, remove this operator from service until the cause of the malfunction is identified and corrected. Keeping this operator in service when the inherent reversing system is malfunctioning creates a hazard for persons which can result in serious injury or death should they become entrapped by the gate/door.

When servicing the gate/door operator, be sure that the AC input power is disconnected.

Operator Component	Maintenance	Monthly Interval		
		3	6	12
Chain	Check for sagging, chain must not rub against steel rail separators. Tighten if necessary. Grease chain if necessary.		✓	
Fire Dept.	Check emergency vehicle access device for proper operation.	✓		
Gate/Door	Inspect for damage. Check gate/door hinges for wear and grease if necessary.		✓	
Loop(s)	Check vehicular reverse and exit loops for proper operation.	✓		
Gearbox Oil	Check oil level, should be at fill mark. Fill if necessary. Use Mobil SHC-629 synthetic gear oil or equivalent.		✓	
Primary Reverse System	Check that the gate/door reverses on contact with an object in both the opening and closing cycles. Adjust the reversing sensors if necessary.	✓		
Release	Check manual release for proper operation.	✓		
External Reverse Device	Check external reverse device(s) stop or reverse the gate/door when activated.	✓		
Complete System	Complete check of gate/door and gate/door operating system.			✓

5.2 Diagnostics Check

Have the following diagnostic tools available: VOM meter with minimum voltage memory or min-max range to check voltage and continuity. Meg-ohm meter capable of checking up to 500 megohms of resistance to properly check ground loop integrity. A malfunction can be isolated to one of the following:

- Gate/Door Operator
- Loop System
- External Keying Devices

Use caution when checking high voltage areas: high voltage input terminal and the main terminals 17 through 19, the motor capacitor and the motor.

Check the input indicator LEDs. They should only come ON when an external keying device (card reader, push button, etc.) is activated. If any of the input LEDs are ON continuously, the gate/door will not operate. Disconnect the external keying devices one at a time until the LED goes OFF.

A malfunction in a loop or loop detector can cause the gate/door operator to hold open, or not detect a vehicle when it is present over the loop. Pull the loop detector circuit boards from the loop ports on the operator circuit board. If the malfunction persists, the problem is not with the loop system. For more information refer to the loop detector instruction sheet and the DoorKing Loop and Loop Detector Information Manual.

Check to be sure that there are no shorted or open control wires from the external keying devices to the gate/door operator. If an external keying device fails to operate the gate/door, momentarily jumper across terminals 6 and 14 on the operator circuit board. If the gate/door operates, this indicates that a problem exist with the external keying device and is not with the operator. Check the high voltage supply. A voltage drop on the supply line (usually caused by using too small supply voltage wires) will cause the operator to malfunction. Refer to the wire size chart on page 15.

5.3 Troubleshooting

Symptom	Possible Solution(s)
Operator will not run – power LED is OFF.	<ul style="list-style-type: none"> • Check that power to the operator is turned ON. • Transformer may be overheated. Turn power off and allow board to cool for several minutes then retest. Check for low 120 VAC power and low voltage shorts. • Check for 120 VAC at terminals 18 and 19. If voltage measures 0, check power. If voltage measures OK, check the terminal strip or replace the circuit board.
Operator will not run – power LED is ON.	<ul style="list-style-type: none"> • If a photocell is used as external entrapment prevention device, check to be sure that the beam is not blocked. • Momentarily jumper terminal 1 to terminal 6 or press “Push to Operate” button. If the input LED does not come ON, check the terminal strip or replace the circuit board. If LED does come ON, proceed to next steps. • Be sure that the chain is not too tight. A too tight chain may cause the operator to stall. • Turn power switch OFF and remove the control board. • Place a jumper wire from terminal 19 to terminal 18. CAUTION – HIGH VOLTAGE. Turn the power switch on. The motor should run. Turn the power switch off and remove the jumper. • Place a jumper wire from terminal 19 to terminal 17. CAUTION – HIGH VOLTAGE. Turn the power switch on. The motor should run in the opposite direction. Turn the power switch off and remove the jumper. • If the motor runs in both steps above, replace the control board. If the motor does not run, or runs in only one direction, problem can be a bad motor, motor capacitor, wire connections from the control board to the motor or a bad control board.
Gate/door opens a short distance, stops and reverses.	<ul style="list-style-type: none"> • Disconnect the gate/door from the gate/door operator and check that the gate/door moves freely without any binding. • Re-adjust the open reverse sensitivity. • Replace the circuit board.
Gate/door opens but will not close.	<ul style="list-style-type: none"> • Check the input LEDs. Any ON will hold the gate/door open and indicates a problem with a external keying device. • Check the external safety devices. Any that are activated will hold the gate/door open and indicates a problem with the safety device. • Check the loop detectors. Any that are activated can hold the gate/door open and indicates a problem with the loop detector or in-ground loop. • SW-2, switch 3 may be set incorrectly. Be sure that this switch is in the ON position for overhead gate/door operation. Activate any external keying device to determine if operator returns to normal operation. • If automatic close timer is desired, be sure SW-1, switch 4 is ON. • Check motor: Place a jumper wire from terminal 19 to terminal 18. CAUTION – HIGH VOLTAGE. Turn the power switch on. The motor should run. Turn the power switch off and remove the jumper. Place a jumper wire from terminal 19 to terminal 17. CAUTION – HIGH VOLTAGE. Turn the power switch on. The motor should run in the opposite direction. Turn the power switch off and remove the jumper. <p>If the motor runs in both steps from previous page, replace the control board. If the motor does not run, or runs in only one direction, problem can be a bad motor, motor capacitor, wire connections from the control board to the motor or a bad control board.</p>

Symptom	Possible Solutions
Gate/door closes but will not open.	<ul style="list-style-type: none"> • SW-2, switch 3 may be set incorrectly. Be sure that this switch is in the ON position for overhead gate/door operation. Activate any keying device to determine if operator returns to normal operation. • Check to be sure that the operator is running in the proper direction. Turn power OFF, and then back ON. Activate an external keying device. Operator should run in the open direction. If operator runs in the close direction, turn power OFF and change direction switch SW-1, switch 1 MUST be ON. Go to the previous symptom if operator now opens but will not close. • Be sure that the respective LED on the control board lights when the external keying device connected to the respective terminal is activated. If LED does not light, momentarily place a jumper wire from terminal 1 to the input terminal being checked. If LED lights and gate/door opens, problem is with the external keying device. If LED does not light, replace control board. • Check motor: Place a jumper wire from terminal 19 to terminal 18. CAUTION – HIGH VOLTAGE. Turn the power switch on. The motor should run. Turn the power switch off and remove the jumper. Place a jumper wire from terminal 19 to terminal 17. CAUTION – HIGH VOLTAGE. Turn the power switch on. The motor should run in the opposite direction. Turn the power switch off and remove the jumper. If the motor runs in both steps above, replace the control board. If the motor does not run, or runs in only one direction, problem can be a bad motor, motor capacitor, wire connections from the control board to the motor or a bad control board.
Gate/door starts to close, then reverses to open.	<ul style="list-style-type: none"> • Re-adjust the close reverse sensitivity. • Disconnect the gate/door from the operator and check that the gate/door operates freely without any binding. • Check the loop detector LEDs and input LEDs. Any that flash ON will cause the gate/door to reverse. • Replace the circuit board.
Gate/door closes and then re-opens.	<ul style="list-style-type: none"> • Check for any input or loop detector LEDs that are ON. • Check that the operator is running in the proper direction, switch SW-1, switch 1 MUST be ON.
Loop detector LED is ON continuously.	<ul style="list-style-type: none"> • Activate the RESET switch on the loop detector. • Decrease loop detector sensitivity. • Check loop wire for resistance to ground with a meg-ohm meter. Should be 100 megohms or higher. If less, problem may be with loop wire. • Be sure that lead-in wire from loop is twisted. • Be sure that all loop connections are soldered. • Replace loop detector.
Loop detector LED never activates.	<ul style="list-style-type: none"> • Increase loop detector sensitivity. • Check continuity of loop wire. Should be 0 ohms. If continuity check indicates greater than 0 ohms, check all connections or replace loop wire. • Move loop detector board to the other loop detector port on the control board, then check loop operation. If loop detector still fails, replace loop board with a known good one. If problem continues, ground loop may be too small to detect vehicles – replace ground loop.
Loop detectors do not open or reverse gate/door.	<ul style="list-style-type: none"> • If loop detector LED illuminates when vehicle crosses over, problem may be in loop detector board. Replace with a known good detector and re-check. If problem continues, control board may be bad. • If loop detector LED does not illuminate, see above symptom.
Operator has intermittent functionality problems that vary.	<ul style="list-style-type: none"> • The main terminal #3 250 mA power has been exceeded. Check total amp draw of connected device(s).

5.4 Accessories

UL 325 Monitored Entrapment Protection Devices available for the model 1175 commercial overhead gate/door operator.

Type B2 Contact Sensors (Reversing Edge)

- Miller Edge Sensing Edges - all models with a T2 (resistive) termination.
- Miller Edge Monitored Gate Link Model MGL-K20
- Miller Edge wireless monitored transmitter/receiver kit model RB-G-K10
- ASO GMBH Sentir GF Series sensing edges

Type B1 Non-contact Sensors (Photo Cell)

- Miller Edge Reflective-Guard Model RG
- Miller Edge Prime-Guard Model PG
- EMX Industries Model IRB-MON
- EMX Industries Model IRB-RET
- Omron Model E3K-R10K4
- Seco-Larm Model E-936-S45RRGQ
- Seco-Larm Model E-960-D90GQ

Monitored Expansion Kit

- Miller Edge Multi-Input Module Model MIM-62

Accessory items available for the model 1175 commercial overhead gate/door operator.

Plug-In Loop Detector - Detectors plug directly into ports on circuit board simplifying wiring.

- Single channel detector - P/N 9410-010
- Dual channel detector - P/N 9409-010
- Single channel detector with aux relay - P/N 9411-010
- Single channel low power draw detector - P/N 9416-010
- Dual channel low power draw detector - P/N 9415-010

External Loop Detector

- Reno A&E 12/24 VDC or 24 VAC - 9402-045
- Reno A&E 120 VAC - 9402-047
- Carlo Gavazzi 24 VAC/VDC - 9402-044
- Diablo 10-30 VAC/VDC low power draw - 9402-050

Loop Wire - 18 AWG loop wire with XLPE insulation is ideal for ground loops. Available in 500 and 1000 foot rolls with red, blue or black insulation.

Pre-Fab Loops - Prefabricated ground loops. 24-foot circumference with 50-foot lead-in. Available in yellow, red or blue jackets.

Not for use in asphalt roadways.

Time Clock - 7 day time clock can be used to automatically open gate at pre-set time and days. Compact clock fits inside the operator.

P/N 2600-791 - 7 day clock

Surge Devices - High and low voltage surge suppressors help prevent circuit board failure caused by lightning strikes and power surges.

P/N 1879-010 - High Voltage

P/N 1878-010 - Low Voltage

Speed Bumps - Prefabricated six-foot speed bump reduces traffic speed through gate/door system. P/N 1610-150

Model 1175 Protective Cover - Prefabricated plastic cover to protect operator components. P/N 1175-020

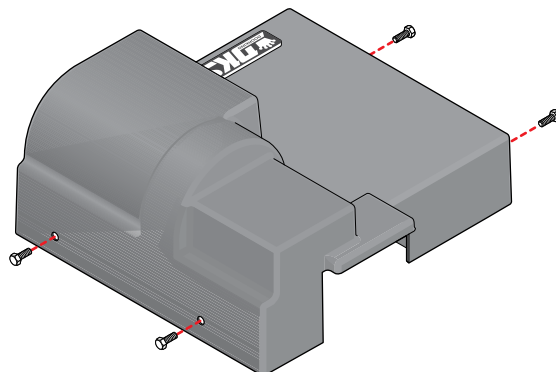

1175 Wiring Schematic

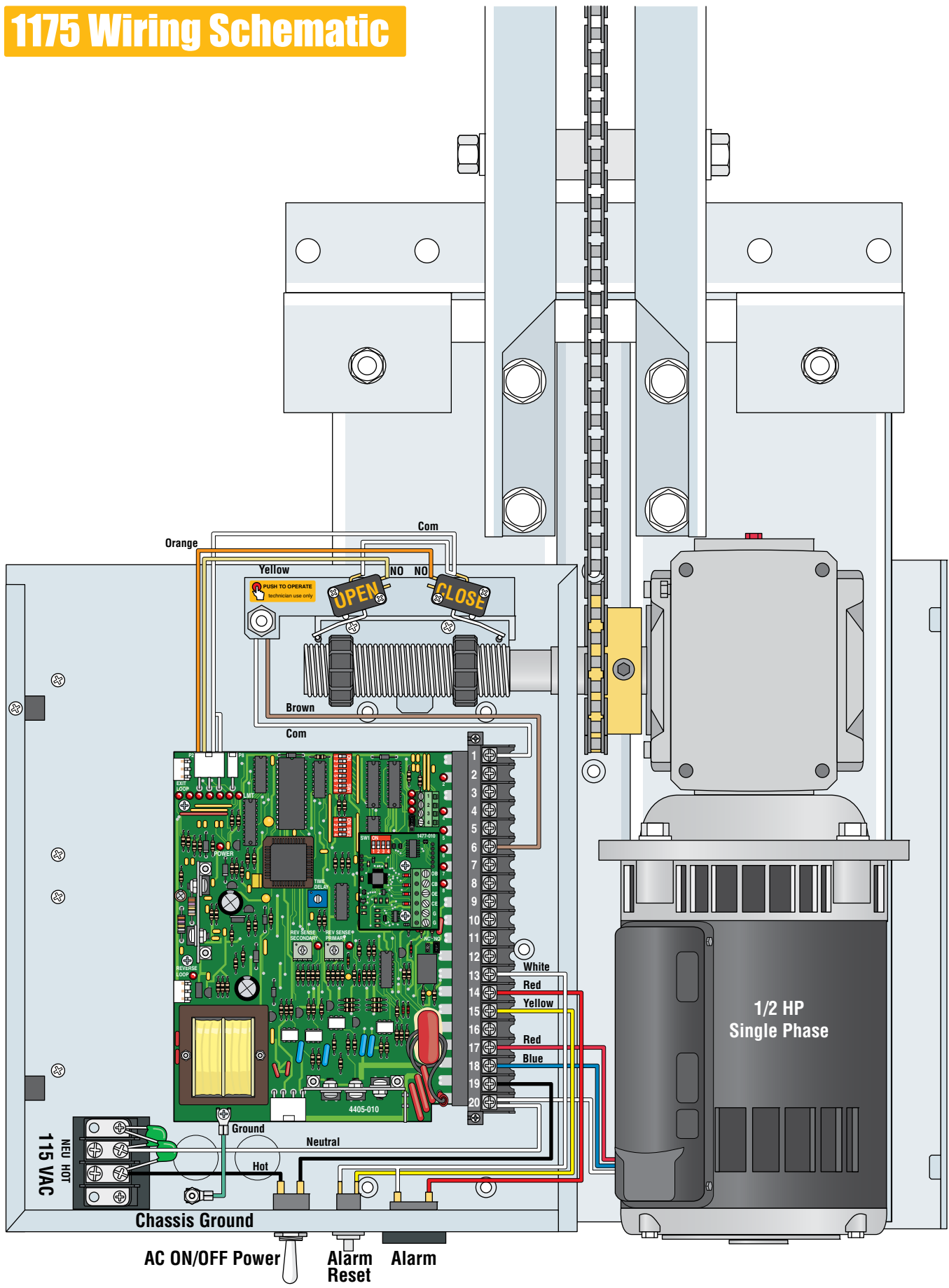

Installation/Owner's Manual

Model 1175

Commercial Overhead Gate/Door Operator

Use this manual for circuit board 4405-010 Revision AA or higher.

1175-065-F-12-17

EXTERNAL ENTRAPMENT PROTECTION MUST be installed or the gate/door operator WILL NOT function.

THIS PRODUCT IS FOR INDOOR USE ONLY.
Install in a protected area **NOT** exposed to weather.



THIS PRODUCT IS TO BE INSTALLED AND SERVICED BY A TRAINED GATE/DOOR SYSTEMS TECHNICIAN ONLY.
Visit www.dkslocator.com to find a professional installing and servicing dealer in your area.

www.doorking.com

DoorKing, Inc.
120 S. Glasgow Avenue
Inglewood, California 90301
U.S.A.
Phone: 310-645-0023
Fax: 310-641-1586