



**Lochinvar**<sup>®</sup>  
HIGH EFFICIENCY BOILERS & WATER HEATERS

**SHIELD™ WATER HEATER**

Submittal Sheet

**SWH-Sub-08**

**SHIELD™ COMMERCIAL GAS WATER HEATER**

Job Name: \_\_\_\_\_ Model No. \_\_\_\_\_

Location: \_\_\_\_\_ Type Gas: \_\_\_\_\_ BTU/Hr  
Input \_\_\_\_\_

Engineer: \_\_\_\_\_ Recovery Rate in GPH \_\_\_\_\_ @ \_\_\_\_\_ °F Rise

Agent/Wholesaler: \_\_\_\_\_ Equipment Tag(s): \_\_\_\_\_

Contractor: \_\_\_\_\_

**NOTES:**

**Standard Features**

- > Up to 96% Thermal Efficiency
- > Modulating Burner with 5:1 Turndown
- > Operates at Temperatures up to 180°F for Sanitizing Applications
- > Stainless Steel Heat Exchanger
- > Glass-Lined Steel Tank
- > Magnesium Anode Rods
- > 150 PSI Working Pressure
- > ASME Construction (SWA150–500)
- > ASME Temperature & Pressure Relief Valve
- > Zero Clearances to Combustible Material
- > Certified for Installation on Combustible Floors
- > PVC, CPVC, Polypropylene and Stainless Steel Venting up to 150 Equivalent Feet
- > Direct-Vent Sealed Combustion
- > Rooftop and Sidewall Venting
- > Advanced SMART CONTROL
  - LCD Display
  - Time Clock
  - Night Setback
  - Alarm Contacts
  - Runtime Contacts
  - Manual Reset High Limit
  - 3 Water Temperature Sensors
  - Flue Temperature Sensor
  - Contacts for Louvers
  - Adjustable Pump Delay
  - Security Protection
  - Enable/Disable Contacts

- > Low-NOx Operation, meets SCAQMD Rule 1146.2
- > Low Gas Pressure Operation
- > Direct-Spark Ignition
- > Brass Drain Valve
- > 8-Foot Power Cord
- > 3-Year Limited Warranty
- > 1-Year Parts Warranty

**Optional Equipment**

- Audible Alarm Kit
- BACnet Communication
- Concentric Vent Kit
- Condensate Neutralization Kit
- CON-X-US® Remote Connectivity
- Flow Switch
- Low Water Cutoff Kit
- Modbus Communication
- Sidewall Vent Termination Kit



# SHIELD COMMERCIAL WATER HEATER – DIMENSIONS AND SPECIFICATIONS

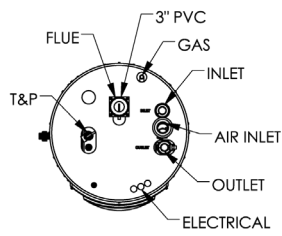

**SW(R,A)125**

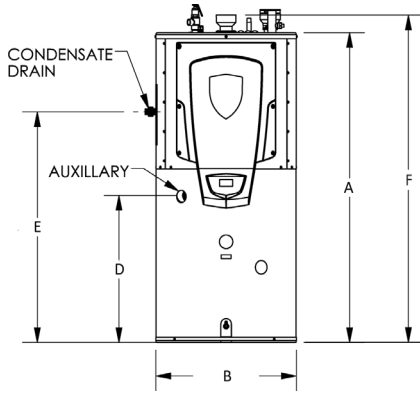

### Model Number Guide

<b>S</b>	<b>W</b>	<b>A</b>	<b>285</b>	<b>N</b>
SHIELD	Water Heater	ASME Construction	285,000 Btu/hr Input	Natural Gas

**SHIELD**  
Water Heater  
**ASME**  
285,000 Btu/hr Input  
Natural Gas

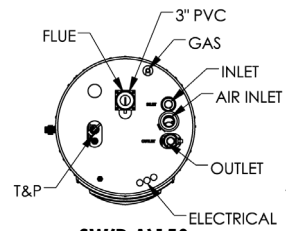

**SW(R,A)150**

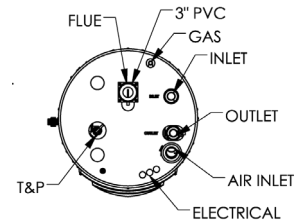
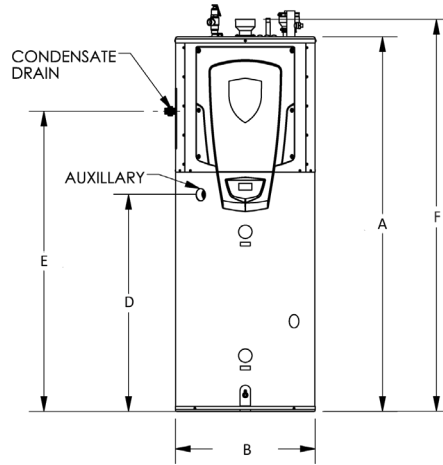

**SW(R,A)200**

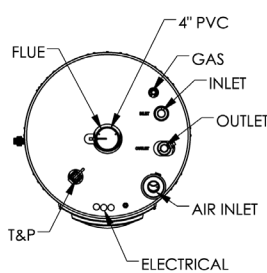
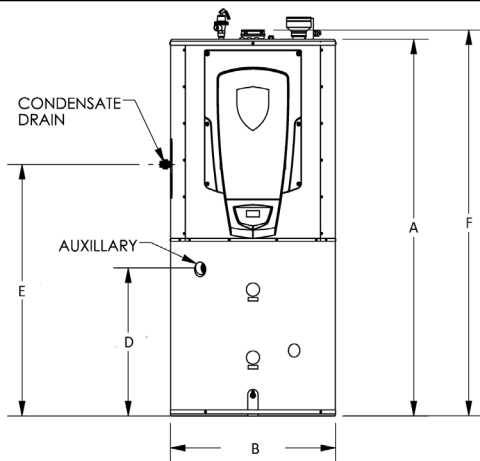

**SW(R,A)285**

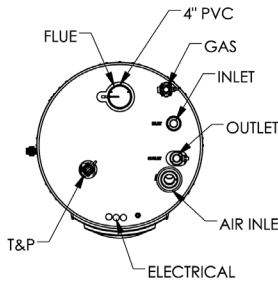

**SW(R,A)400**

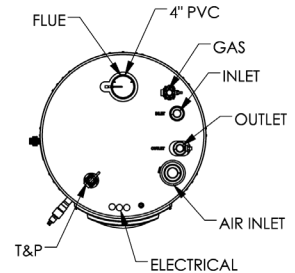

**SWA500**

Model Number	Btu/hr Input	Capacity (Gals.)	Thermal Eff.	GPH @ 100° Rise	1st Hour	A	B	D	E	F	Gas Conn.	Water Conn.	Air Inlet	Vent Size	Ship Wgt. (lbs.)
<b>Regular Construction</b>															
SWR125N	125,000	65	96%	145	197	62 1/2"	28"	29-1/2"	46 1/2"	66"	1/2"	1-1/2"	3"	3"	377
SWR150N	150,000	90	96%	175	247	76"	28"	44"	61"	79-1/2"	1/2"	1-1/2"	3"	3"	700
SWR200N	199,000	90	96%	232	304	76"	28"	44"	61"	79-1/2"	1/2"	1-1/2"	3"	3"	725
SWR285N	285,000	110	95%	328	416	77-1/2"	34"	30-1/2"	51-3/4"	79-1/2"	1/2"	1-1/2"	4"	4"	800
SWR400N	399,000	110	95%	459	547	77-1/2"	34"	30-1/2"	51-3/4"	79-1/2"	1"	1-1/2"	4"	4"	850
<b>ASME Construction</b>															
SWA150N	150,000	90	96%	175	247	76"	28"	44"	61"	79-1/2"	1/2"	1-1/2"	3"	3"	700
SWA200N	199,000	90	96%	232	304	76"	28"	44"	61"	79-1/2"	1/2"	1-1/2"	3"	3"	725
SWA285N	285,000	110	95%	328	416	77-1/2"	34"	30-1/2"	51-3/4"	79-1/2"	1/2"	1-1/2"	4"	4"	800
SWA400N	399,000	110	95%	459	547	77-1/2"	34"	30-1/2"	51-3/4"	79-1/2"	1"	1-1/2"	4"	4"	850
SWA500N	500,000	110	96%	582	670	77-1/2"	34"	30-1/2"	51-3/4"	79-1/2"	1"	1-1/2"	4"	4"	875

Change "N" to "L" for LP gas. Field convertible to LP Gas.

A = ASME Construction / Check local and state codes for ASME requirements

Electrical Requirements: 120V/1PH/60Hz

All Information is subject to change without notice.



Lochinvar, LLC  
300 Maddox Simpson Parkway  
Lebanon, Tennessee 37090  
P: 615.889.8900 | F: 615.547.1000  
Lochinvar.com



LOW LEAD CONTENT

HLW