

# Installation

## Phenolic Restroom Partitions Floor-Mounted with Overhead Brace Series 400

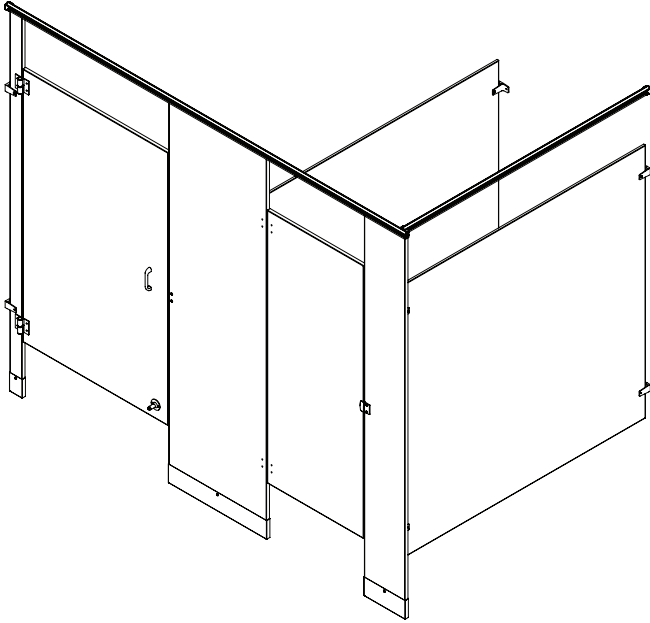

**For Standard Height  
Doors and Panels Only**

### Table of Contents

Pre-Installation Information . . . . .	2-3
Layout Dimensions for Brackets . . . . .	4
Mounting Brackets to Wall . . . . .	5-6
Leveling Screws to Pilaster . . . . .	6
Mounting Brackets to Pilasters . . . . .	7-8
Pilaster Mounting Hardware . . . . .	8
Pilasters and Panels . . . . .	9-11
Wall Hung Pilasters . . . . .	12-14
Pilaster Shoes . . . . .	15
Headrail . . . . .	16
Hinges . . . . .	17-19
Door Hardware . . . . .	20-21
Urinal Screens . . . . .	22-24



## **⚠ WARNING**

Before beginning installation, make sure that the wall and floor backing are adequate to support the secure mounting of the toilet compartment units.

Partitions are extremely heavy and may require more than one person to position and install.

Failure to comply with these instructions may result in personal injury and/or property damage and will void the partition warranty.

## **⚠ CAUTION**

Personal protective equipment (PPE) is required during the installation and maintenance of this product.

## **NOTICE**

To prevent warping, always lay the material flat. Do not lean the material against the wall or stack unevenly.

Make sure all floors and walls are clean and smooth. Remove loose impediments, such as protruding nails and other debris which could affect installation.

To minimize break-out, always use a support block when drilling through the material.

Carefully remove components from skid, do not drag.

## **IMPORTANT**

Review your partition layout drawings and verify the number of stalls and components before beginning installation.

Read this installation manual completely to ensure proper installation, then file it with the owner or maintenance department. This installation manual provides instruction for the assembly of normal partition configurations and standard components. Non-standard configurations or components including but not limited to curved or angled walls, partial walls, oversized panels, or modified hardware are not covered in this manual. Compliance and conformity to local codes and ordinances is the responsibility of the installer.

Separate parts from packaging and make sure all parts are accounted for before discarding packaging material. If any parts are missing, do not begin installation until you obtain the missing parts.

Product warranties and parts information may be found under "Products" on Bradley's website at [bradleycorp.com](http://bradleycorp.com).

**Supplies Required:**

- Chalk line and pencil
- Tape measure and 4' level
- Jigsaw (or hacksaw) and circular saw
- Two spring clamps
- 11/64", 15/64", 7/32", 1/4" and 17/64" drill bits
- Power drill or screw gun with drill bit extension
- 5/16" ceramic tile and masonry drill bit
- Hammer drill
- Spacer, 12" (305mm) high and strong enough to support weight of panel

**Hardware Provided**

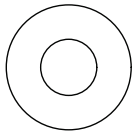

9/32" x 5/8"  
Washer Flat  
P10-449

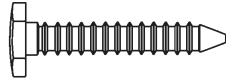

5/16" x 1-1/2"  
Hex Head  
Lag Screw  
FAST-S008



#14-16 Plastic  
Anchor  
FAST-T373



#14 x 2"  
Button-Head  
Sheet Metal Screw  
Torx-T27 Drive  
FAST-P002



#14 x 5/8"  
Button-Head  
Sheet Metal Screw  
Torx-T27 Drive  
FAST-S0016



#10 x 5/8"  
Button-Head  
Sheet Metal Screw  
Torx-T27 Drive  
FAST-S0019



#10 x 1"  
Button-Head  
Sheet Metal Screw  
Torx-T27 Drive  
FAST-S0028



#10 x 3/4"  
Flat-Head  
Sheet Metal Screw  
Torx-T25 Drive  
FAST-S0006



#10-24 x 3/8"  
Button-Head  
Machine Screw  
Torx-T27 Drive  
FAST-S0015



#10-24 x 1/2"  
Button-Head  
Shoulder Screw  
Torx-T27 Drive  
FAST-S0018



#10-24 x 3/4"  
Button-Head  
Shoulder Screw  
Torx-T27 Drive  
FAST-P004

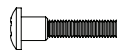

#10-24 x 1"  
Button-Head  
Shoulder Screw  
Torx-T27 Drive  
FAST-P004A



#10-24 x 1/2"  
Button-Head  
Barrel Nut  
Torx-T27 Drive  
FAST-S0017



#10-24 x 2"  
Flat-Head  
Machine Screw  
Torx-T25 Drive  
FAST-S0027

**Example of Submittal Drawing**

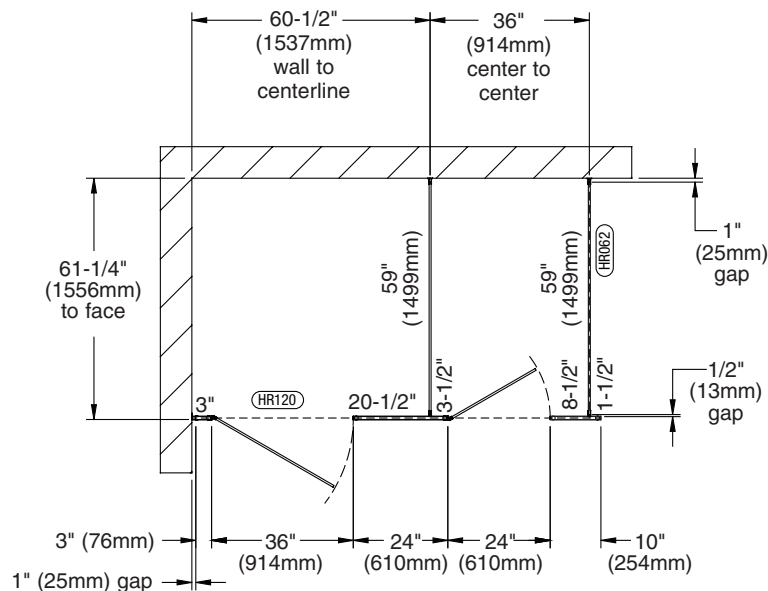

### 1 Layout Dimensions - Stirrup Brackets (Standard)

When installing the partition components, consult the applicable Mills Partition submittal drawing for compartment layout dimensions.

**A Pilaster Centerline:** Measure from the back wall forward to the face of the compartment, subtract 3/8" (10mm) and mark this location on the floor ("A"). Mark the same measurement on the opposite end of your layout ("A1") and draw a straight line connecting both marks.

**For Freestanding (FS) Partitions:** Refer to submittal drawings and determine the approximate location of the outside panels. Establish dimensions "A" and "A1" as explained above.

**C** Draw a plumb line on all walls from each pilaster and panel centerline. From the highest point in the room, measure 18" (457mm) and 64" (1626mm) from the floor and place a mark on the pilaster/panel plumb line. These marks represent the hole center line of the stirrup brackets. Use a level to transfer that mark to all other plumb lines ("C").

**B Panel Centerline:** Measure the stall width across the back wall and place a mark at the base of the rear wall ("B"). Repeat this step for each panel, starting each measurement from the last panel centerline ("B1").

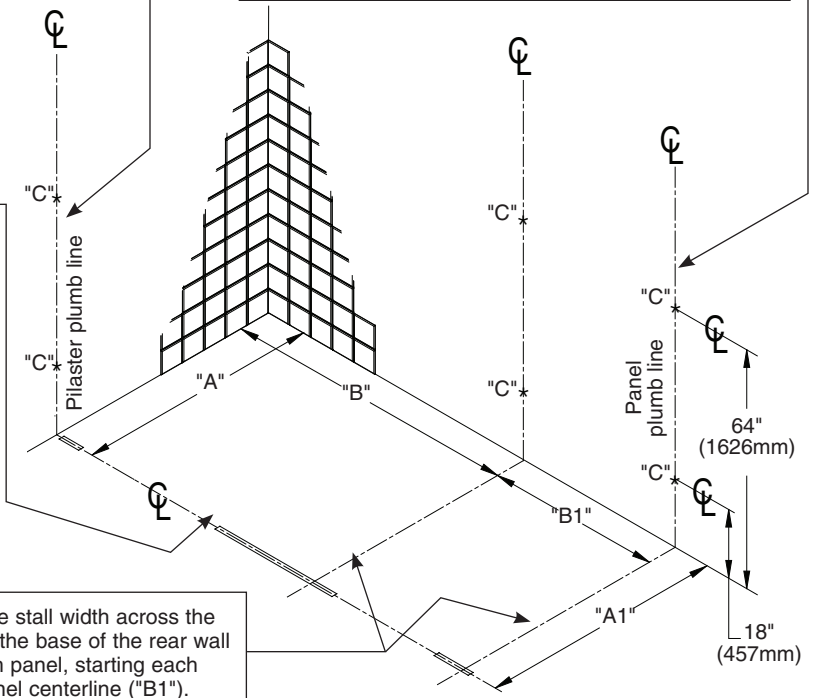

### 1a Layout Dimensions - Continuous Brackets (Optional)

When installing the partition components, consult the applicable Mills Partition submittal drawing for compartment layout dimensions.

**A Pilaster Centerline:** Measure from the back wall forward to the face of the compartment, subtract 3/8" (10mm) and mark this location on the floor ("A"). Mark the same measurement on the opposite end of your layout ("A1") and draw a straight line connecting both marks.

**For Freestanding (FS) Partitions:** Refer to submittal drawings and determine the approximate location of the outside panels. Establish dimensions "A" and "A1" as explained above.

**C** Draw a plumb line on all walls from each pilaster and panel centerline. From the highest point in the room, measure from the floor and place a mark on the pilaster/panel plumb line at dimension "C" for the respective bracket type (see table below). Use a level to transfer that mark to all other plumb lines ("D").

	Dim "C"
Stainless Steel	12-1/2" (318mm)
Aluminum	12-1/4" (311mm)

**B Panel Centerline:** Measure the stall width across the back wall and place a mark at the base of the rear wall ("B"). Repeat this step for each panel, starting each measurement from the last panel centerline ("B1").

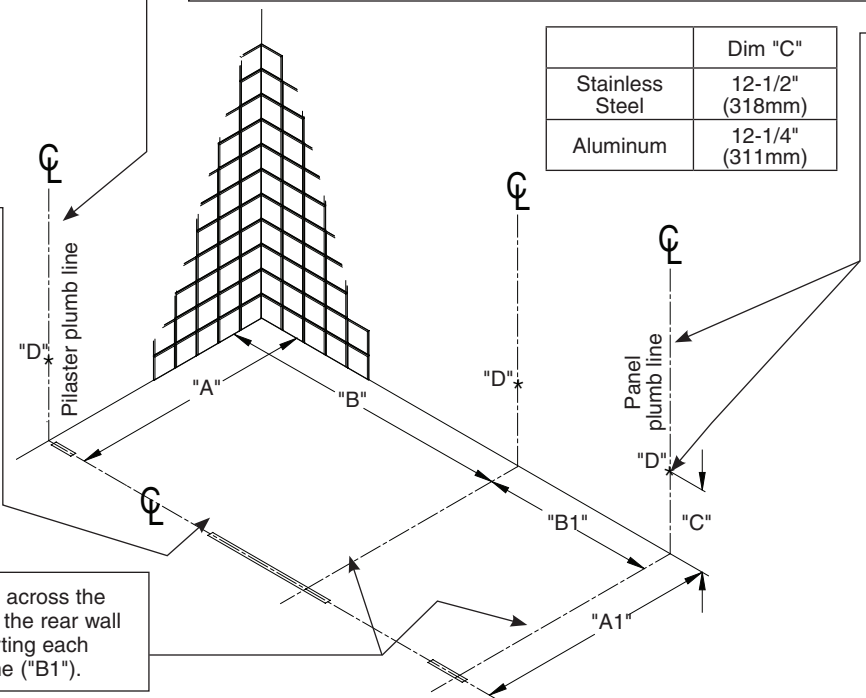

## 2 Stirrup Brackets to Wall (Standard)

- On end panel and pilaster applications, position the bracket with the ear facing toward the inside of the stall.
- Pilaster bracket is shown here. 3/4" opening brackets are for pilasters and 1/2" opening brackets are for panels.

**A** Place the center of each stirrup bracket at the established level line. Center the bracket opening on the pilaster/panel plumb line.

**B** Using the bracket as a template, mark the hole locations on the wall. Remove the bracket and drill a Ø5/16" hole (min. 2" [51mm] deep) at each hole location.

**C** Insert the plastic anchors in all holes and secure the brackets to the wall with the #14 x 2" screws provided.

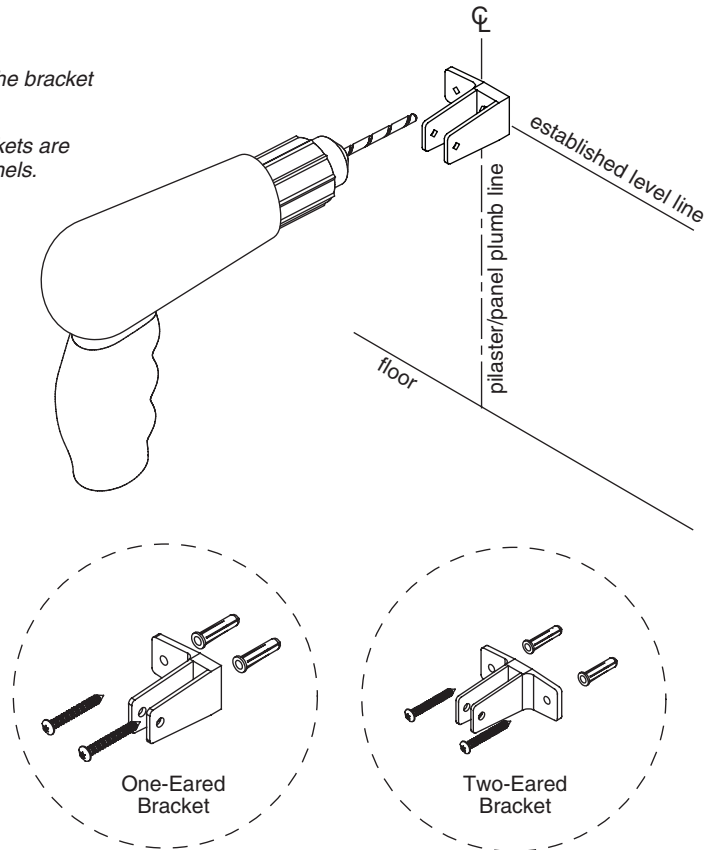

## 2a Continuous Stainless Steel Brackets to Wall (Optional)

- On pilaster applications, position the bracket with the ear facing toward the inside of the stall.
- Pilaster bracket shown here; "EAR" brackets are for pilasters and "U" brackets are for panels.
- Brackets are used as templates, but since the hole patterns may be different, the brackets may not be interchangeable.

**A** Place the bottom of each continuous bracket at the established level line. Center the bracket opening on the pilaster/panel plumb line.

**B** Using the bracket as a template, mark the hole locations on the wall. Remove the bracket and drill a Ø5/16" hole (min. 2" [51mm] deep) at each hole location.

**C** Insert the plastic anchors in all holes and secure the brackets to the wall with the #14 x 2" screws provided.

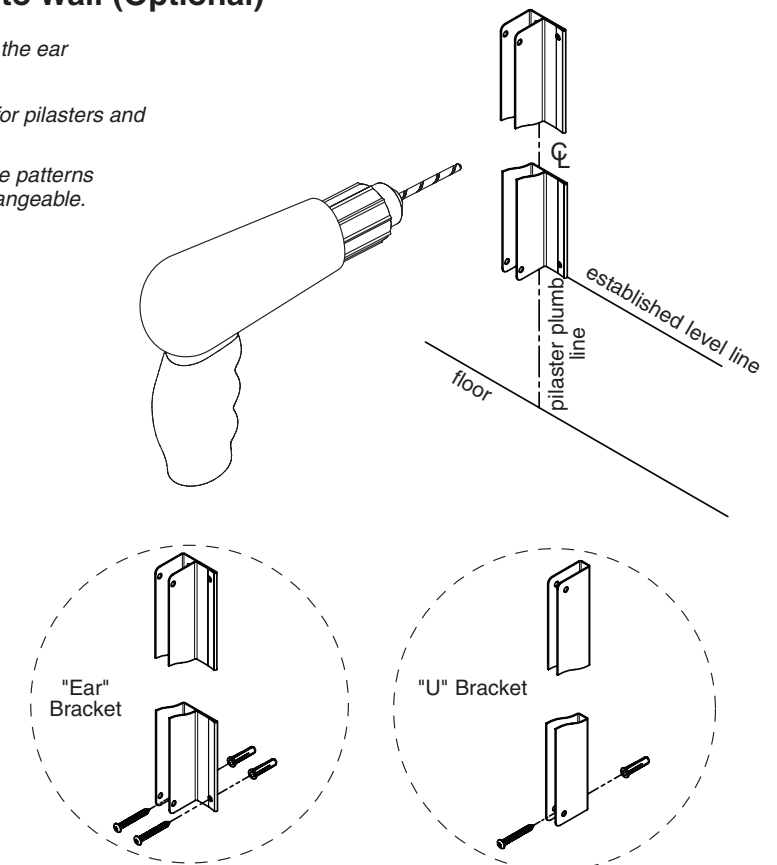

### 2b Continuous Aluminum Brackets to Wall (Optional)

- ✓ On end panel and pilaster applications, position the bracket with the ear facing toward the inside of the stall.
- ✓ Pilaster bracket is shown here; 3/4" opening brackets are for pilasters, and 1/2" opening brackets are for panels.
- ✓ Brackets are used as templates, but since the hole patterns may be different, the brackets may not be interchangeable.

**A** Place the bottom of each continuous bracket at the established level line. Center the bracket opening on the pilaster/panel plumb line.

**B** Using the bracket as a template, mark the hole locations on the wall. Remove the bracket and drill a Ø5/16" hole (min. 2" [51mm] deep) at each hole location.

**C** Insert the plastic anchors in all holes and secure the brackets to the wall with the #14 x 2" screws provided.

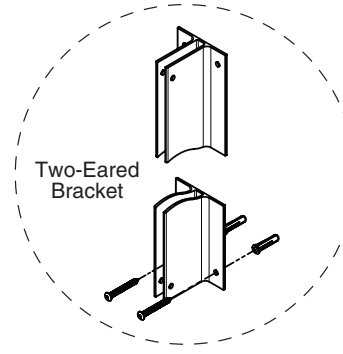
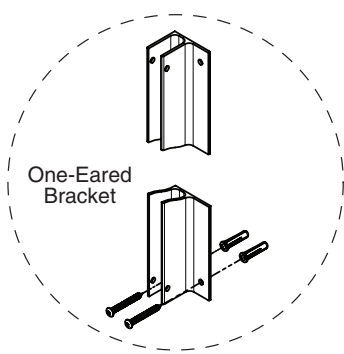
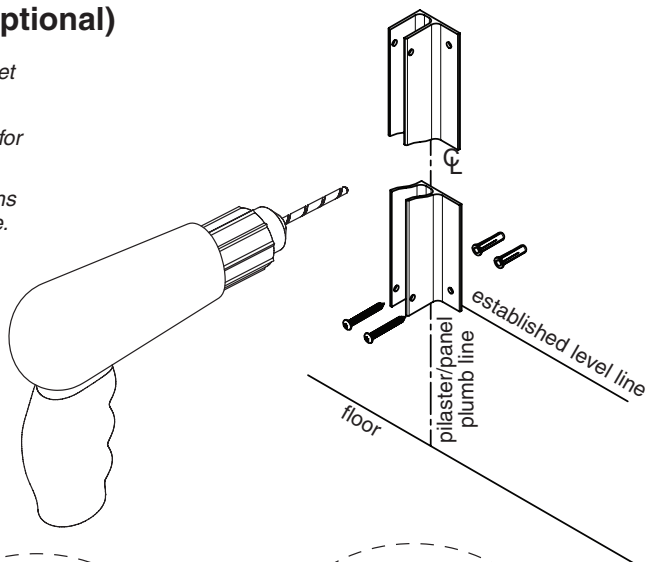

### 3 Leveling Screws to Pilaster

- ✓ When pilasters are pre-drilled (optional), a notch will be present on one end of the pilaster to indicate that it is the bottom.

**A** **3" - 16" Pilaster:** Center and drill a Ø17/64" pilot hole, 1-1/2" (38mm) deep.  
**18" - 24" Pilaster:** Drill (2) Ø17/64" pilot holes, 1-1/2" (38mm) deep. Holes should be 2" (51mm) off each end of the pilaster.

**B** Use leveling screw(s) to adjust height of pilaster as indicated based on pilaster width.

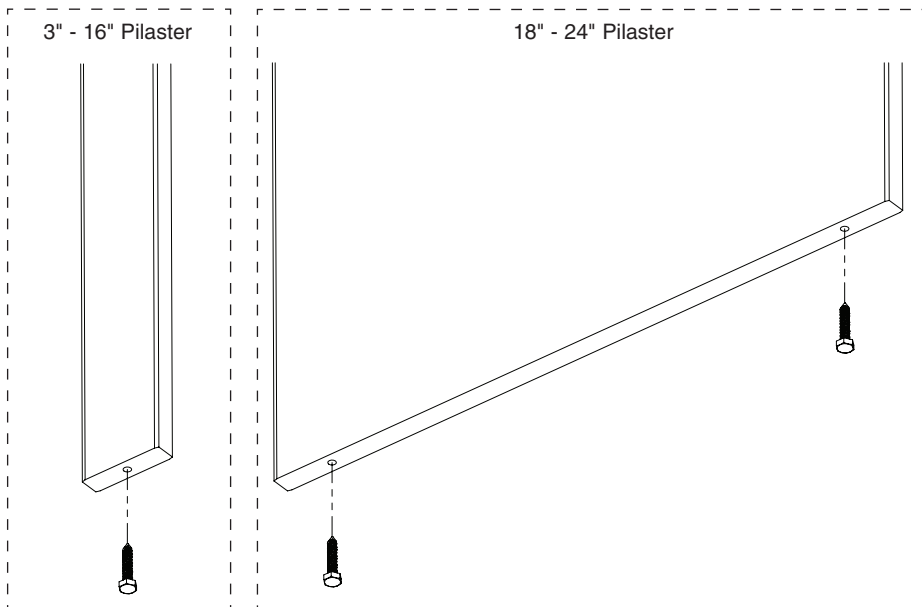

### 4 Stirrup Brackets to Pilaster (Standard)

Refer to the submittal drawing to locate the split dimension and layout location of each marked pilaster.

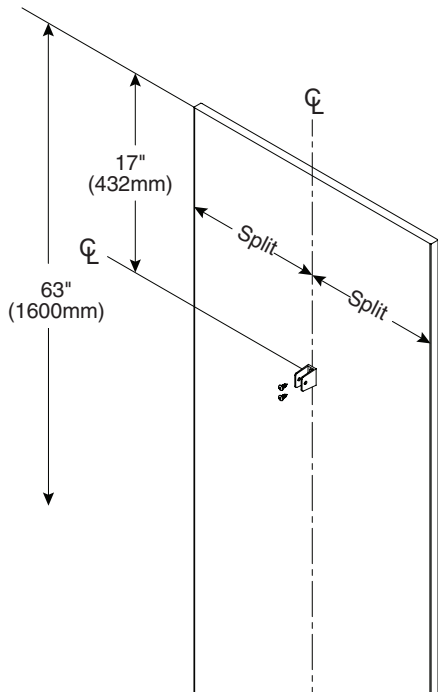

**A** Measure 17" (432mm) and 63" (1600mm) down from the top of each pilaster and place a mark on the pilaster split centerline.

Pilaster shown is for reference only. Actual pilaster varies depending on application.

**B** Place stirrup brackets at each established level line. Center the bracket opening on the pilaster split centerline. Using the bracket as a template, mark the hole locations on the pilaster. Remove the bracket and drill a Ø15/64" pilot hole, 5/8" (16mm) deep at each location.

**C** Secure the stirrup brackets to the pilasters using the #14 x 5/8" screws provided.

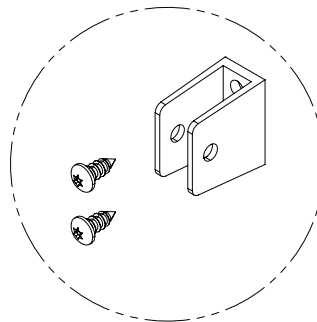

### 4a Continuous Brackets to Pilaster (Optional)

Refer to the submittal drawing to locate the split dimension and layout location of each marked pilaster.

Brackets are used as templates, but since the hole patterns may be different, the brackets may not be interchangeable.

Continuous stainless steel bracket shown.

	Dim. "A"	Dim. "B"
Stainless Steel Bracket	11-1/2" (292mm)	68-1/2" (1740mm)
Aluminum Bracket	11-1/4" (286)	68-3/4" (1746mm)

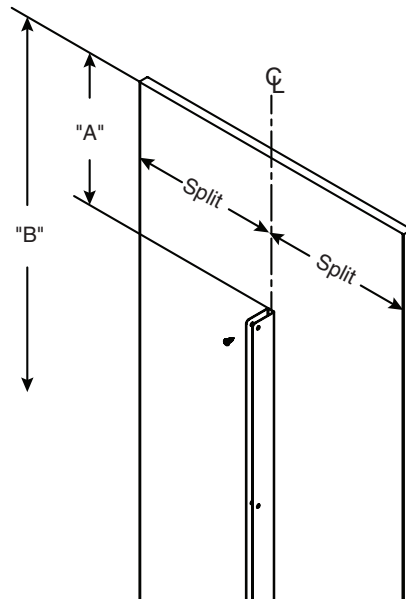

**A** Measure down from the top of the pilaster and place a mark on the pilaster centerline at dimensions "A" and "B" for the respective bracket (see table on left).

Pilaster shown is for reference only. Actual pilaster varies depending on application.

**B** Place the continuous bracket between each established level line. Center the bracket opening on the pilaster split centerline. Using the bracket as a template, mark the hole locations on the pilaster. Remove the bracket and drill a Ø15/64" pilot hole, 5/8" (16mm) deep at each location.

**C** Secure the continuous bracket to the pilasters using the #14 x 5/8" screws provided.

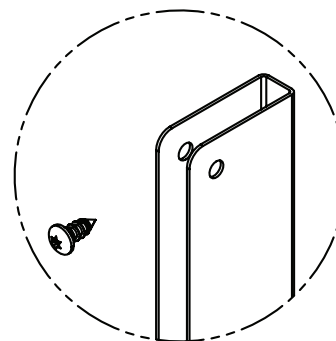

### 4b Alcove Brackets to Pilaster

Layouts that use continuous aluminum brackets for pilaster and panel connections will use stirrup brackets for alcove connections. Continuous stainless steel brackets use continuous alcove brackets.

Refer to the submittal drawing for the layout location of each alcove pilaster

**A** Measure down from the top of the pilaster and place a mark at dimensions shown for the respective bracket situation.

**B** **Stirrup:** Position the center of each bracket at the marks made in Step A.  
**Continuous:** Center the bracket between each mark made in Step A.

**C** Using the bracket as a template, mark the hole locations on the pilaster. Remove the bracket and drill  $\text{\O}1/4"$  holes through the pilaster at each location.

**D** **Stirrup:** Secure the brackets to the pilaster using the #10-24 x 1/2" barrel nuts and #10-24 x 3/4" shoulder screws provided.  
**Continuous:** Secure the brackets to the pilaster using the #10-24 x 1/2" barrel nuts and #10-24 x 1/2" shoulder screws provided.

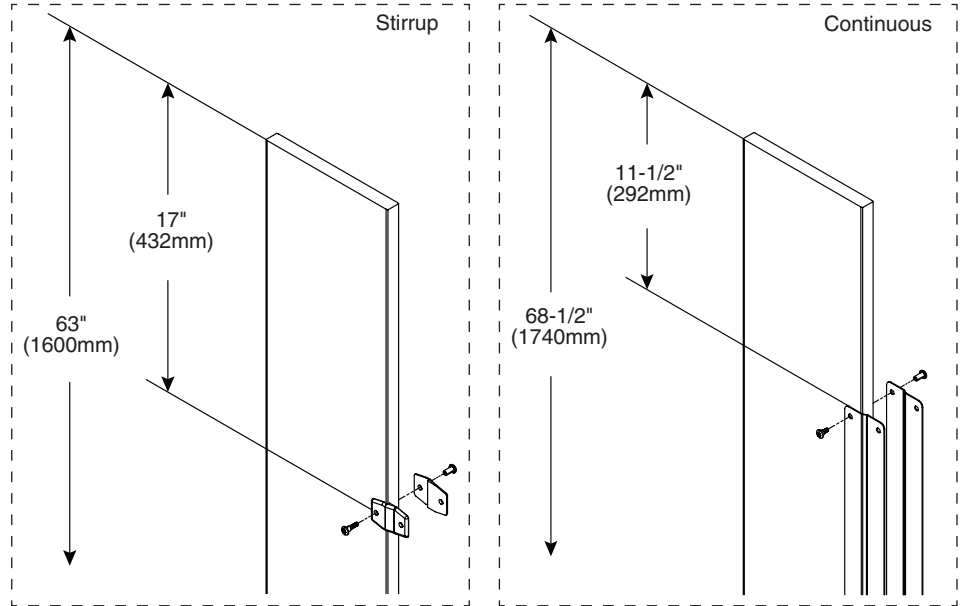

### 5 Pilaster Mounting Hardware

**A** Starting with the pilaster closest to the wall, measure and mark the pilaster and door widths on the pilaster centerline. Make sure to leave the appropriate gap between the wall and the pilaster. Place corresponding shoe on the pilaster centerline and center between the marks.

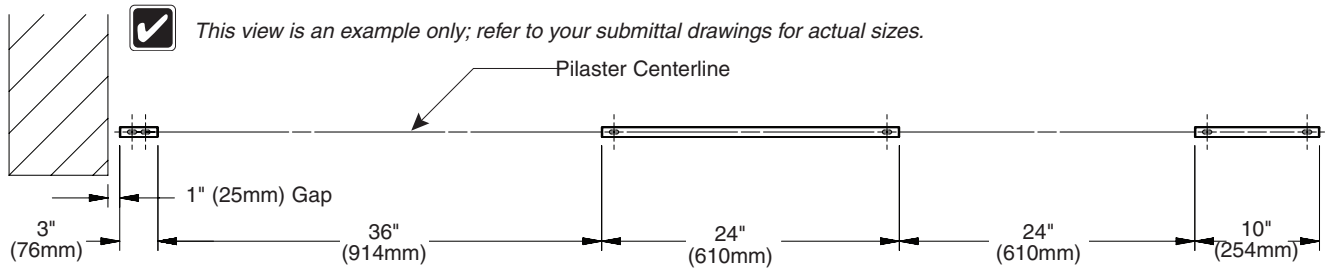

**B** Using the shoe as a template, mark the hole locations on the floor. Remove the shoe and drill  $\text{\O}5/16"$  holes (min 2" [51mm] deep) into the floor. Make sure the holes are free of dirt and debris.

**C** Insert plastic anchors into the holes and secure the shoe to the anchors using the 9/32" x 5/8" flat washer and #14 x 2" screws provided.

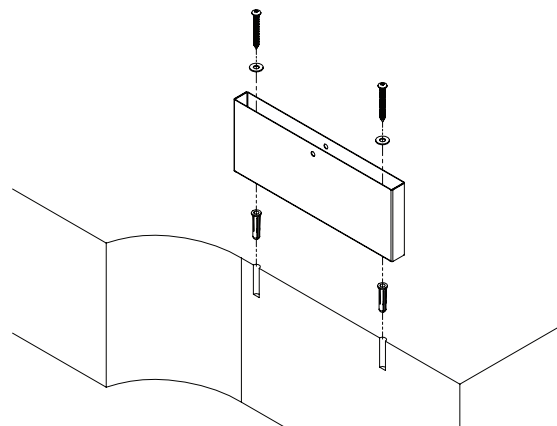



**6 Pilasters and Panels with Stirrup Brackets (Standard)**

- Pilasters located at walls should be mounted first. Start at one end and install a panel, then a pilaster. Continue alternating until installation is complete. When installing in an alcove or in-corner, use an alcove bracket to secure the pilaster to the panel.
- Check to make sure the pilasters are plumb and level to each other. The pilaster height can be adjusted with the leveling screw that was placed at the bottom of the pilaster (see page 5 for attaching leveling screw).

**Pilasters at Wall**

- When installing pilasters at walls, the gaps range from 1/2" to 1-1/4" (13mm to 32mm). Refer to your submittal drawing for your gap sizes.

**A** Place the pilaster within the shoe while at the same time placing it within the wall brackets.

**B** Using the bracket as a template, drill Ø1/4" holes through the pilaster at each pilaster bracket hole. Secure the pilaster to the bracket using the #10-24 x 1/2" barrel nuts and #10-24 x 3/4" shoulder screws provided.

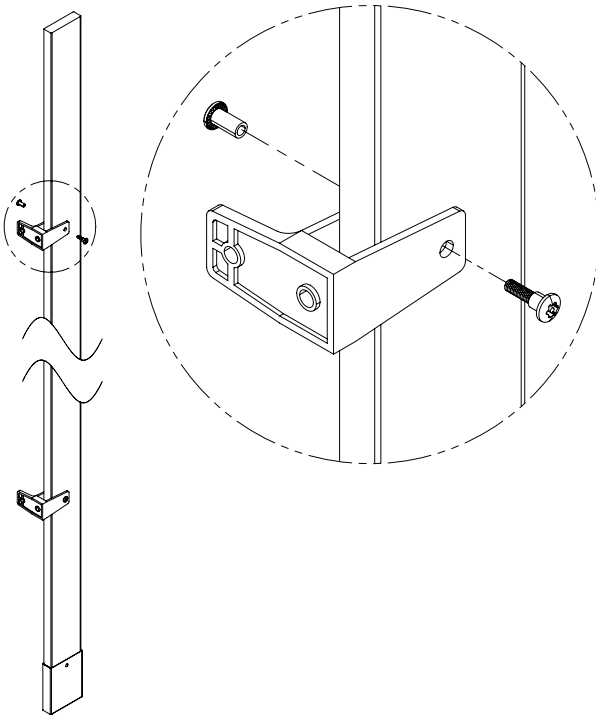

**Pilasters with Panels**

- Refer to your submittal drawing and leave the appropriate gaps. Standard gap is 1" (25mm) between the panel and wall and 1/2" (13mm) between the panel and pilaster.

**A** Place the panel on the spacer and insert the panel into the wall brackets.

**B** Place the pilaster within the shoe while at the same time placing the brackets around the panel.

**C** Using the bracket as a template, drill Ø1/4" holes through the panel at each panel bracket hole. Secure the panel to the bracket using the #10-24 x 1/2" barrel nuts and #10-24 x 1/2" shoulder screws provided.

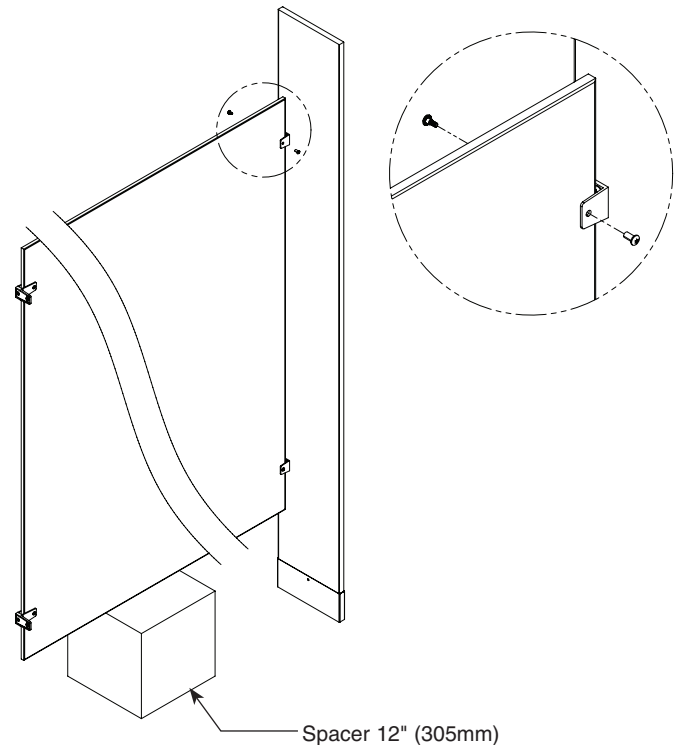

**6a Pilasters and Panels with Stainless Steel Continuous Brackets (Optional)**

- Pilasters located at walls should be mounted first. Start at one end and install a panel, then a pilaster. Continue alternating until installation is complete. When installing in an alcove or in-corner, use an alcove bracket to secure the pilaster to the panel.
- Check to make sure the pilasters are plumb and level to each other. The pilaster height can be adjusted with the leveling screw that was placed at the bottom of the pilaster (see page 5 for attaching leveling screw).

**Pilasters at Wall**

- When installing pilasters at walls, the gaps range from 1/2" to 1-1/4" (13mm to 32mm). Refer to your submittal drawing for your gap sizes.

**A** Place the pilaster within the shoe while at the same time placing it within the wall bracket.

**B** Using the bracket as a template, drill Ø1/4" holes through the pilaster at each pilaster bracket hole. Secure the pilaster to the bracket using the #10-24 x 1/2" barrel nuts and #10-24 x 1/2" shoulder screws provided.

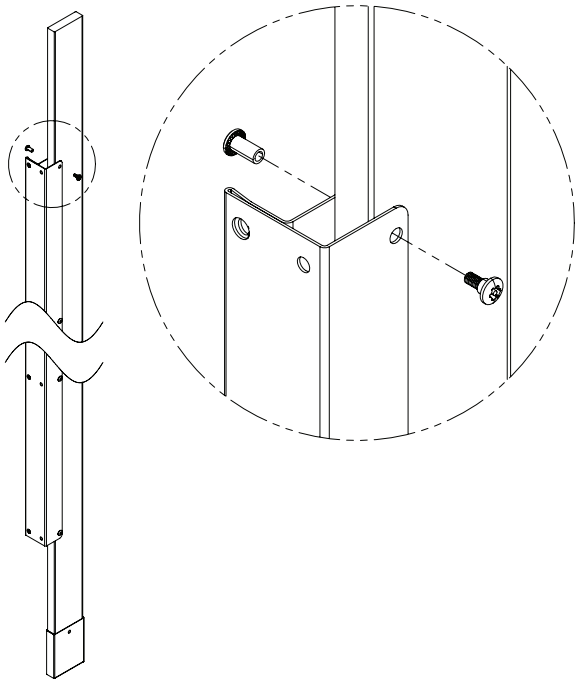

**Pilasters with Panels**

- Refer to your submittal drawing and leave the appropriate gaps. Standard gap is 1" (25mm) between the panel and wall and 1/2" (13mm) between the panel and pilaster.

**A** Place the panel on the spacer and insert the panel into the wall bracket.

**B** Place the pilaster within the shoe while at the same time placing the bracket around the panel.

**C** Using the bracket as a template, drill Ø1/4" holes through the panel at each panel bracket hole. Secure the panel to the bracket using the #10-24 x 1/2" barrel nuts and #10-24 x 3/8" machine screws provided.

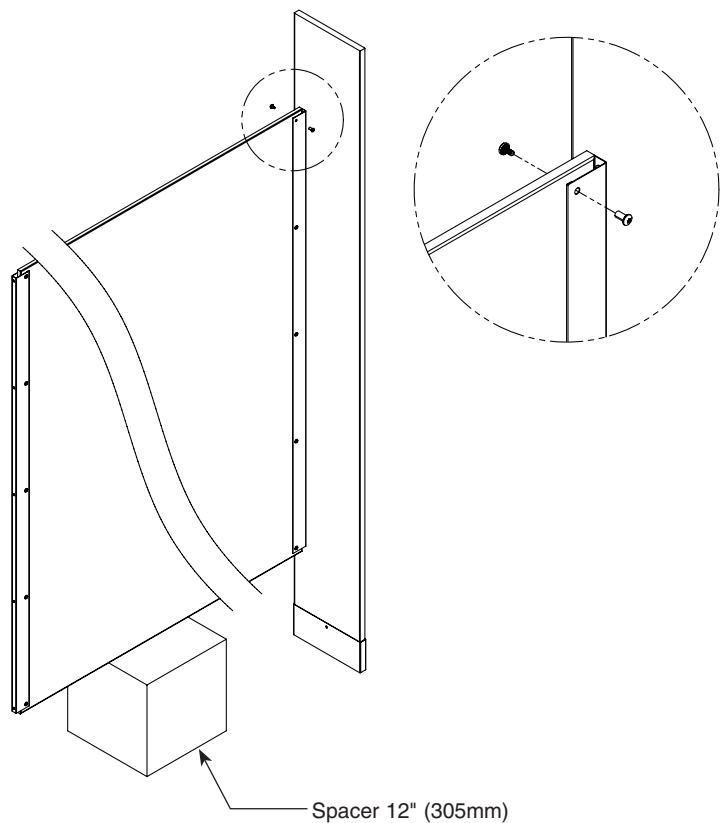

**6b Pilasters and Panels with Aluminum Continuous Brackets (Optional)**

- Pilasters located at walls should be mounted first. Start at one end and install a panel, then a pilaster. Continue alternating until installation is complete. When installing in an alcove or in-corner, use an alcove bracket to secure the pilaster to the panel.*
- Check to make sure the pilasters are plumb and level to each other. The pilaster height can be adjusted with the leveling screw that was placed at the bottom of the pilaster (see page 5 for attaching leveling screw).*

**Pilasters at Wall**

- When installing pilasters at walls, the gaps range from 1/2" to 1-1/4" (13mm to 32mm). Refer to your submittal drawing for your gap sizes.*

**A** Place the pilaster within the shoe while at the same time placing it within the wall bracket.

**B** Using the bracket as a template, drill Ø1/4" holes through the pilaster at each pilaster bracket hole. Secure the pilaster to the bracket using the #10-24 x 1/2" barrel nuts and #10-24 x 3/4" shoulder screws provided.

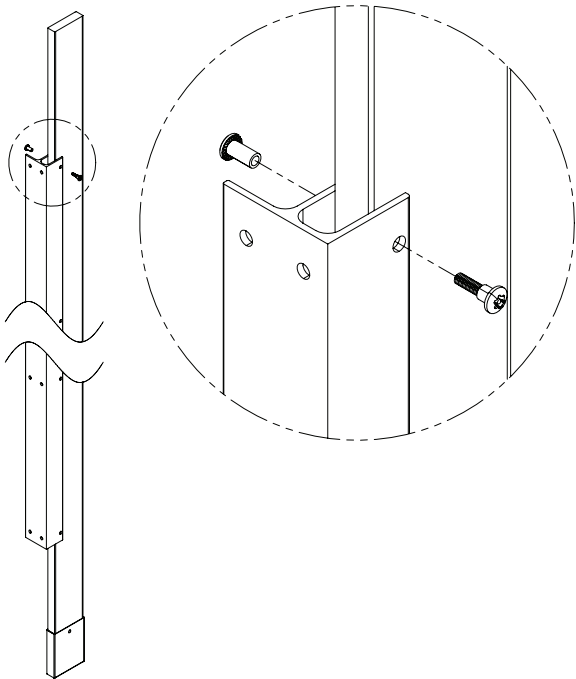

**Pilasters with Panels**

- Refer to your submittal drawing and leave the appropriate gaps. Standard gap is 1" (25mm) between the panel and wall and 1/2" (13mm) between the panel and pilaster.*

**A** Place the panel on the spacer and insert the panel into the wall bracket.

**B** Place the pilaster within the shoe while at the same time placing the bracket around the panel.

**C** Using the bracket as a template, drill Ø1/4" holes through the panel at each panel bracket hole. Secure the panel to the bracket using the #10-24 x 1/2" barrel nuts and #10-24 x 1/2" shoulder screws provided.

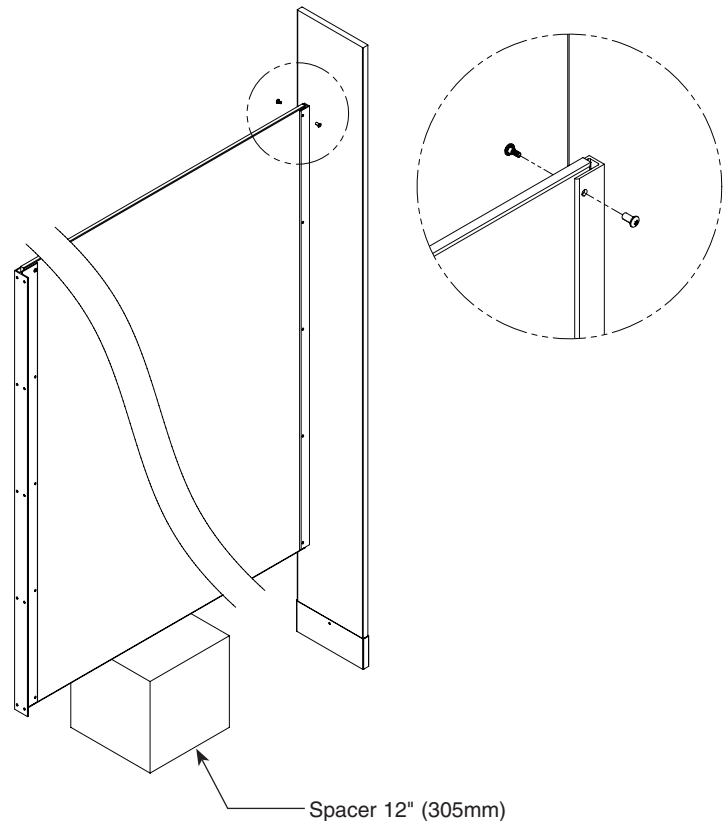

**6c Wall-Hung Pilasters (58" or 69-9/16") - Stirrup Brackets (Optional)**

- See Step 2 for instructions on mounting the stirrup brackets to a wall.
- See Step 4 for instructions on mounting the stirrup brackets to a pilaster.
- To establish level line, from the highest point in the room, measure 12" (305mm) from the floor. Use a level to transfer this mark to the pilaster plumb line.
- Pilasters shown in (2) different lengths for visual reference.

**Pilasters at Wall**

- A** Slide the wall-hung pilaster into the stirrup brackets and align with the established level line. Refer to the submittal drawing and adjust to meet the specified dimension.
- B** Using the bracket as a template, drill  $\text{\O}1/4"$  holes through the pilaster at each pilaster bracket hole. Secure the pilaster to the bracket using the #10-24 x 1/2" barrel nuts and #10-24 x 3/4" shoulder screws provided.

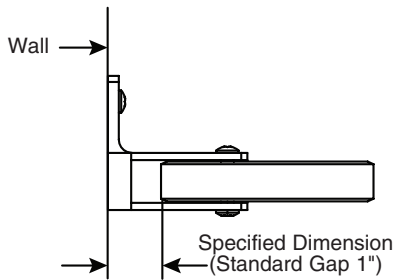

58" (1473mm) Pilaster

69-9/16" (1767mm) Pilaster

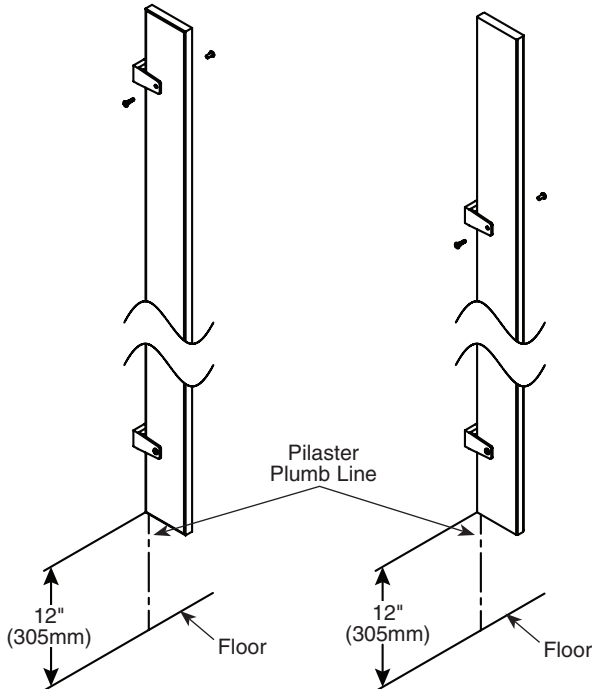

**Pilasters at Pilasters**

- A** Slide the wall-hung pilaster into the stirrup brackets and align with the established level line. Refer to the submittal drawing and adjust to meet the specified dimension.
- B** Using the bracket as a template, drill  $\text{\O}1/4"$  holes through the pilaster at each pilaster bracket hole. Secure the pilaster to the bracket using the #10-24 x 1/2" barrel nuts and #10-24 x 3/4" shoulder screws provided.

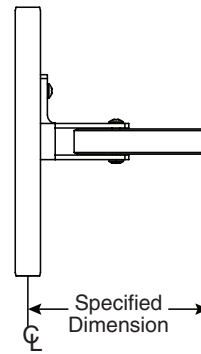

58" (1473mm) Pilaster

69-9/16" (1767mm) Pilaster

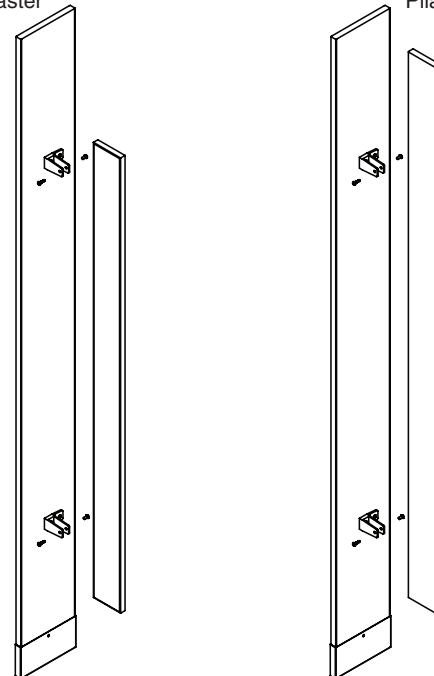

**6d Wall-Hung Pilasters (58" or 69-9/16") - Continuous Stainless Steel Brackets (Optional)**

- See Step 2a for instructions on mounting the continuous stainless steel brackets to a wall.
- See Step 4a for instructions on mounting the continuous stainless steel brackets to a pilaster.
- To establish level line, from the highest point in the room, measure 12" (305mm) from the floor. Use a level to transfer this mark to the pilaster plumb line.
- Pilasters shown in (2) different lengths for visual reference.

**Pilasters at Wall**

**A** Slide the wall-hung pilaster into the continuous bracket and align with the established level line. Refer to the submittal drawing and adjust to meet the specified dimension.

**B** Using the bracket as a template, drill  $\text{Ø}1/4"$  holes through the pilaster at each pilaster bracket hole. Secure the pilaster to the bracket using the #10-24 x 1/2" barrel nuts and #10-24 x 1/2" shoulder screws provided.

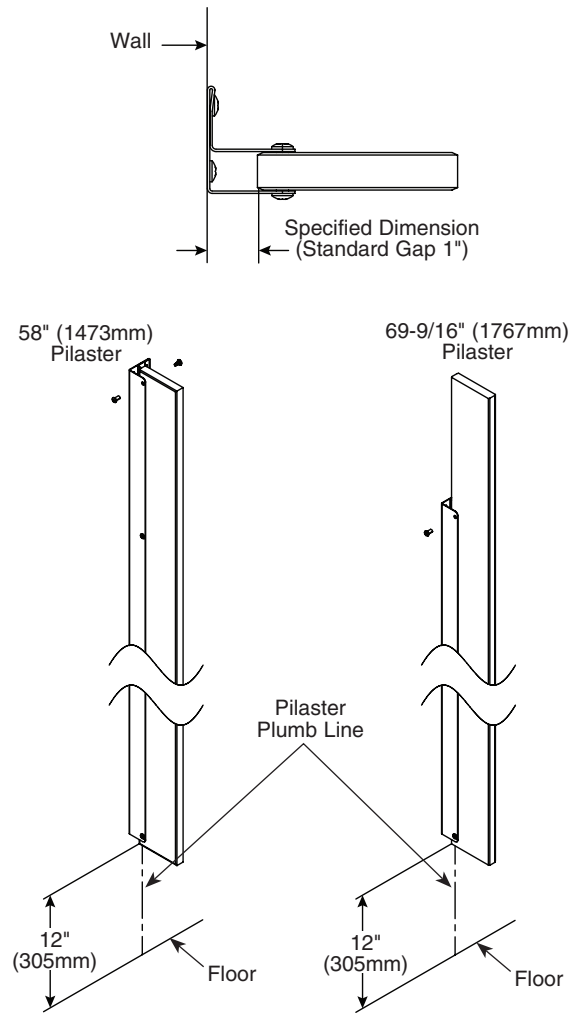

**Pilasters at Pilasters**

**A** Slide the wall-hung pilaster into the continuous bracket and align with the established level line. Refer to the submittal drawing and adjust to meet the specified dimension.

**B** Using the bracket as a template, drill  $\text{Ø}1/4"$  holes through the pilaster at each pilaster bracket hole. Secure the pilaster to the bracket using the #10-24 x 1/2" barrel nuts and #10-24 x 1/2" shoulder screws provided.

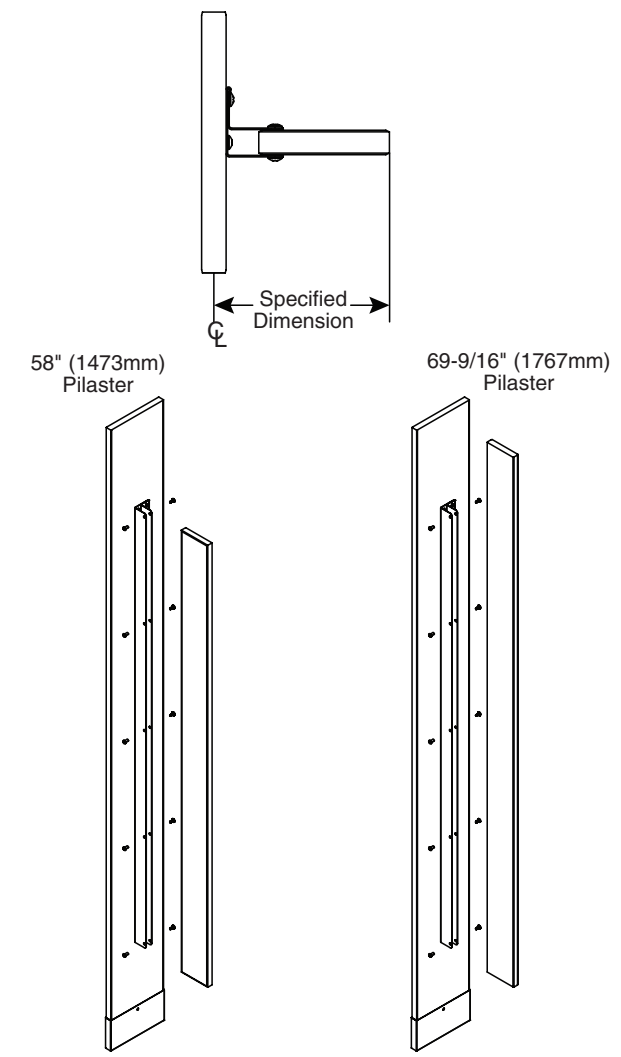

**6e Wall-Hung Pilasters (58" or 69-9/16") - Continuous Aluminum Brackets (Optional)**

- ✓ See Step 2b for instructions on mounting the continuous aluminum brackets to a wall.
- ✓ See Step 4a for instructions on mounting the continuous aluminum brackets to a pilaster.
- ✓ To establish level line, from the highest point in the room, measure 12" (305mm) from the floor. Use a level to transfer this mark to the pilaster plumb line.
- ✓ Pilasters shown in (2) different lengths for visual reference.

**Pilasters at Wall**

**A** Slide the wall-hung pilaster into the continuous bracket and align with the established level line. Refer to the submittal drawing and adjust to meet the specified dimension.

**B** Using the bracket as a template, drill  $\text{\O}1/4"$  holes through the pilaster at each pilaster bracket hole. Secure the pilaster to the bracket using the #10-24 x 1/2" barrel nuts and #10-24 x 3/4" shoulder screws provided.

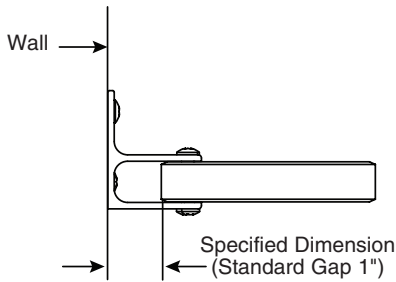

58" (1473mm) Pilaster

69-9/16" (1767mm) Pilaster

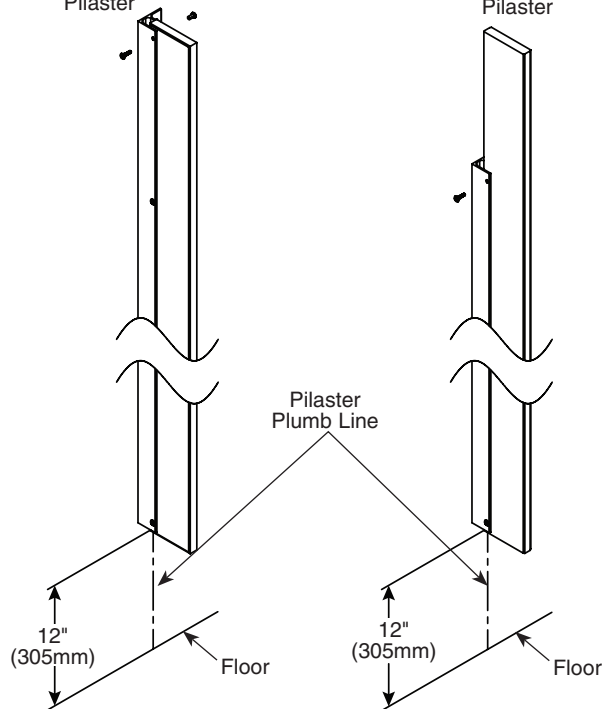

**Pilasters at Pilasters**

**A** Slide the wall-hung pilaster into the continuous bracket and align with the established level line. Refer to the submittal drawing and adjust to meet the specified dimension.

**B** Using the bracket as a template, drill  $\text{\O}1/4"$  holes through the pilaster at each pilaster bracket hole. Secure the pilaster to the bracket using the #10-24 x 1/2" barrel nuts and #10-24 x 3/4" shoulder screws provided.

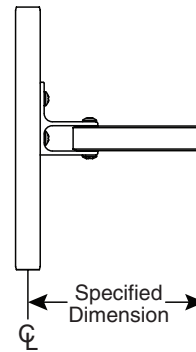

58" (1473mm) Pilaster

69-9/16" (1767mm) Pilaster

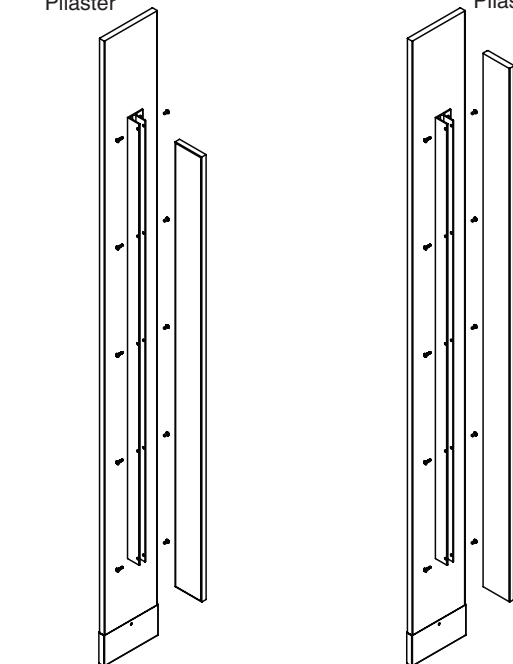

**7 Pilaster Shoes**

**A** Using the hole in the shoe as a template, drill a  $\text{Ø}1/4"$  hole through the pilaster.

**B** Secure the pilaster to the shoe using the #10-24 x  $1/2"$  barrel nut and #10-24 x  $3/4"$  shoulder screw provided.

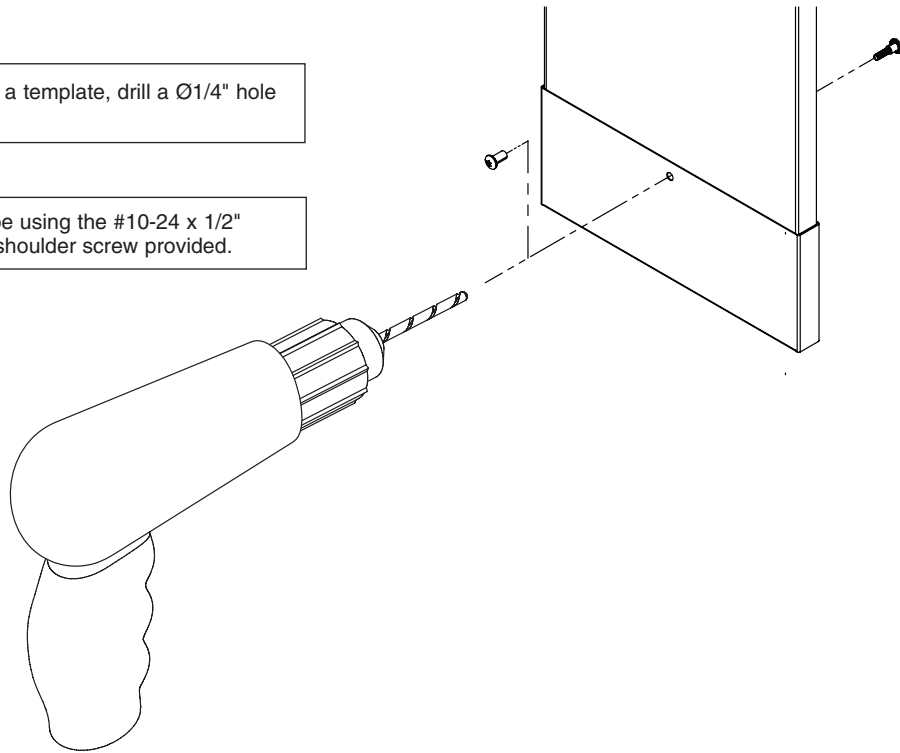

**8 Headrail**

- ✓ Make sure the pilasters are plumb and that the pilaster has been secured to the shoe. Leave the appropriate door opening between the pilasters as shown on your submittal drawing.
- ✓ The illustrations on this page show mounting hardware and fasteners for a generic application. Refer to your submittals to determine your actual headrail configurations.
- ✓ Some headrail sections may need to be cut to an appropriate size. Refer to your submittals for general headrail placement.
- ✓ Headrail configurations that come to an intersection should meet over a pilaster (see completed headrail assembly view below).

**A** Place headrail over the top of each pilaster located at the wall and slide it tight against the side wall. Mark the outline of the headrail on the wall and remove the headrail.

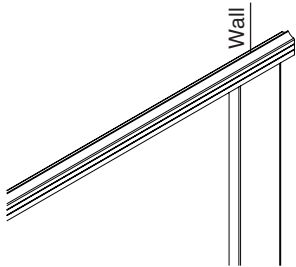

**B** Place the headrail bracket on the outline marked on the wall and mark the locations of the mounting holes. Remove bracket and drill (2) Ø5/16" holes a minimum of 2" (51mm) deep. Prior to securing to the wall, enlarge the (2) back mounting holes of the bracket to Ø1/4". Secure the bracket to the wall with the #14 x 2" screws and plastic anchors provided.

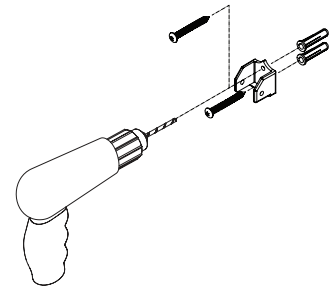

**C** Place headrail over the top of the pilasters and slide it tight into the mounting bracket. Use the mounting bracket as a template and drill a Ø7/32" hole through the headrail. Secure the headrail to the mounting bracket with the #10 x 5/8" screws provided.

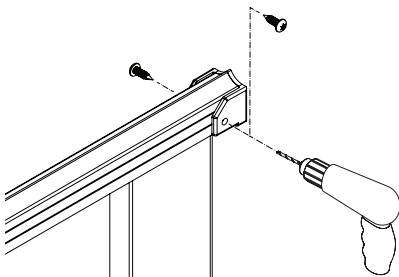

**D** Make sure the pilaster is plumb and that the spacing between the pilasters for the doors is the correct dimension. On the back of each pilaster (starting with the first pilaster), drill a Ø7/32" hole through one face of the headrail only. Using this hole as a template, drill a Ø11/64" pilot hole into the pilaster, 5/8" (16mm) deep. Secure the headrail to the back of each pilaster with the #10 x 5/8" screws provided.

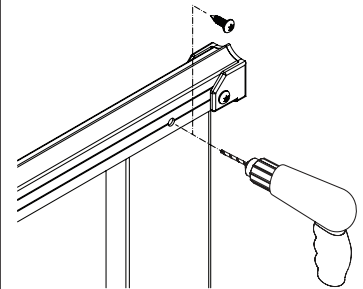

**E** For open end applications, cut the headrail to the appropriate length (if required). Attach the bracket to the wall at the correct height (see step B). Attach another bracket to a pilaster with #10 x 5/8" screws at the correct height (see view below). The headrail should be level with any adjacent headrail and should be located directly over the panel. Position each headrail onto the brackets and secure with required fasteners (see step C). Using a rubber mallet, install the headrail end cap.

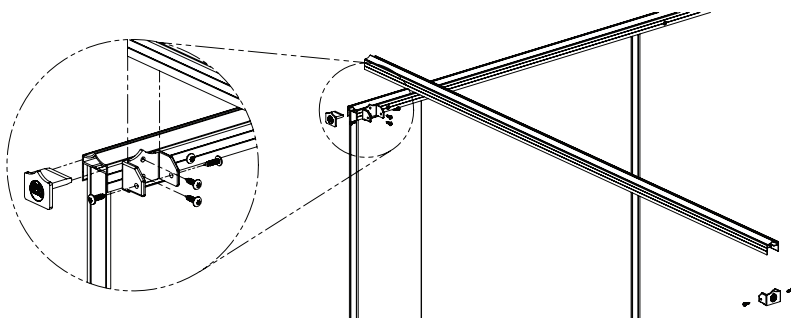

**Completed Headrail Assembly**

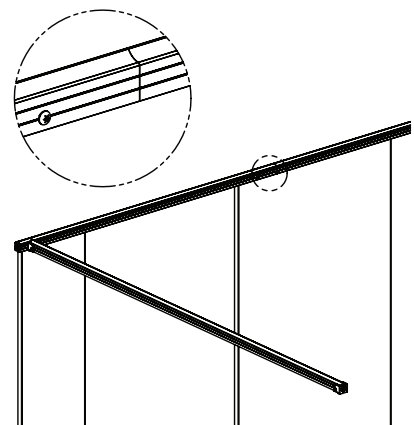



## 9 Surface-Mounted Hinges (Standard)

- Before installing the hinges, make sure the door openings are the appropriate size, all pilasters are plumb and secured to the shoe, and that the headrail is installed.
- Refer to your submittal drawings to determine each specific door swing for your application. The door swing is determined by facing the compartment from the outside. The image below can help determine the door swing type.

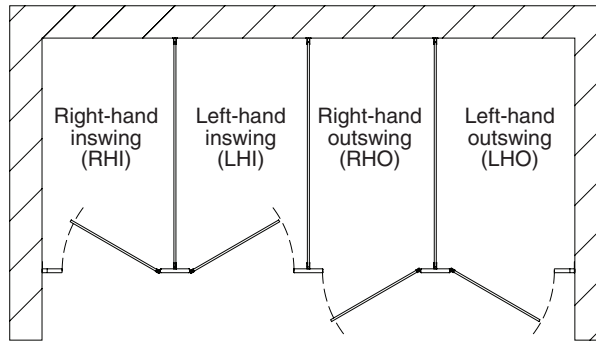

### Surface Hinge Kits

The part numbers listed below are prefixes only and are used to identify the appropriate door kit based on your door swing as determined above. Inswinging doors should have hinges mounted on the inside of the stall while outswinging doors should have hinges mounted on the outside of the stall.

Part # Prefix	Description	Part # Prefix	Description
HDWC-SD1-LH	left hand in	HDWC-SD2-LH	left hand out
HDWC-SD1-RH	right hand in	HDWC-SD2-RH	right hand out

**Floor Mounted Overhead Braced**

**Wall Hung 69-9/16" (1767mm)**

**Wall Hung 58" (1473mm)**

**A**

At 1-1/32" (26mm) from the edge of the pilaster, measure down from the top and place a mark at dimensions "A" and "B" for the respective pilaster type (see table below). This mark represents the upper hole location of the top and bottom hinge.

**B**

Using the hinge as a template, drill Ø1/4" holes through the pilaster.

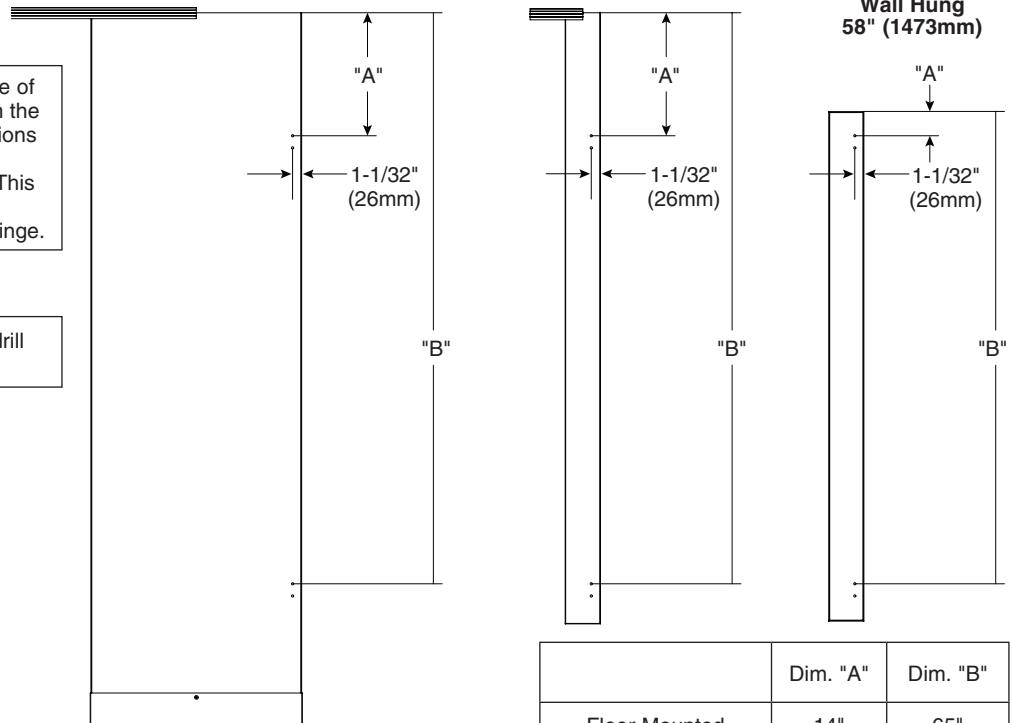

	Dim. "A"	Dim. "B"
Floor Mounted Overhead Braced	14" (356mm)	65" (1651mm)
Wall Hung 69-9/16" (1767mm)	14" (356mm)	65" (1651mm)
Wall Hung 58" (1473mm)	2-3/4" (70mm)	53-3/4" (1365mm)

## 9 Surface-Mounted Hinges (Continued)

The knuckle gap of the top hinge varies based on the pintle setting.

Left-hand outswing door shown.

**C** Secure the top and bottom hinge to the pilaster with the #10-24 x 1/2" barrel nuts and #10-24 x 3/4" shoulder screws provided.

**D** Adjust the ribs on the pintle to align with the notches on the top hinge and set the door's "at rest" position to 0° (see detail below).

**E** With the door in the closed position, place on a 12" (305mm) spacer and set the gap between the door and pilaster to 3/16" (5mm).

**F** Using the top and bottom hinge as a template, drill  $\varnothing 1/4"$  holes through the door. Secure the bottom hinge to the door using the #10-24 x 1/2" barrel nuts and #10-24 x 3/4" shoulder screws provided.

**G** If 0° is the desired "at rest" position, continue to step H; otherwise, remove the door side of the top hinge and adjust the ribs on the pintle to align with the notches on the top hinge to set the desired "at rest" position.

When "at rest" position is greater than 0°, push top hinge flat against the door surface and raise door accordingly to align the holes drilled in step F.

**H** Secure the top hinge to the door using the #10-24 x 1/2" barrel nuts and #10-24 x 3/4" shoulder screws provided.

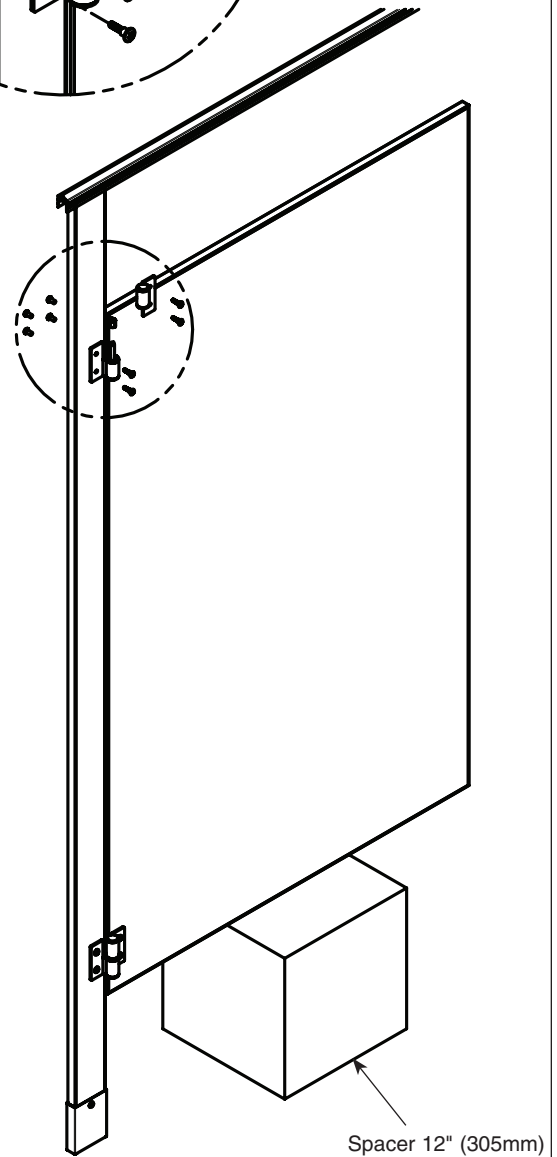
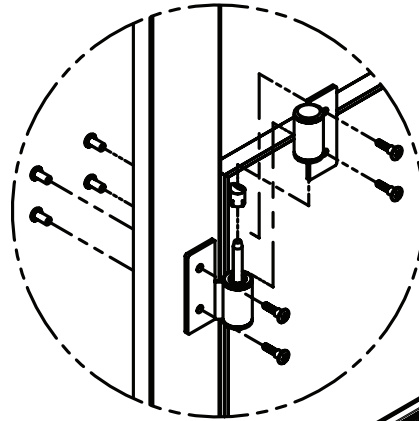

Finished View of Top Hinge

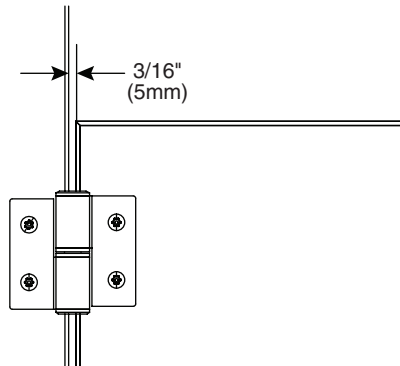

Lining up pintle groove with this mark will set the door "at rest" position at 0°

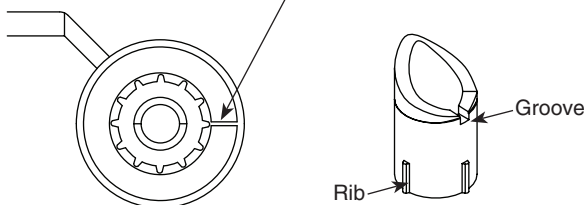

**9a Continuous Spring-Loaded Piano Hinge (Optional)**

- Before installing the hinges, make sure the door openings are the appropriate size, all pilasters are plumb and secured to the shoe, and that the headrail is installed.
- Refer to your submittal drawings to determine each specific door swing for your application. The door swing is determined by facing the compartment from the outside. The image below can help determine the door swing type.

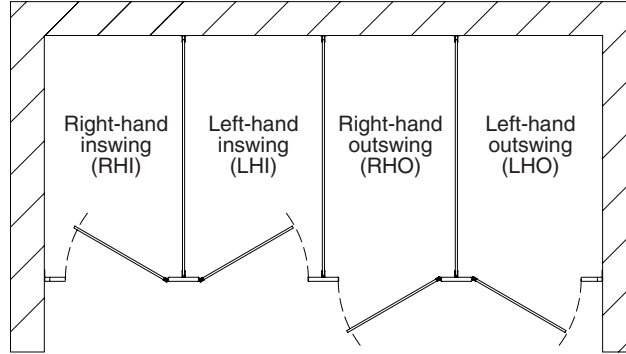

**Continuous Piano Hinge**

The part numbers listed are prefixes only and are used to identify the appropriate door kit based on your door swing as determined above. Inswinging doors should have hinges mounted on the inside of the stall while outswinging doors should have hinges mounted on the outside of the stall.

Part # Prefix HDWT-S0209  
(left hand in, right hand out, knuckles facing front)

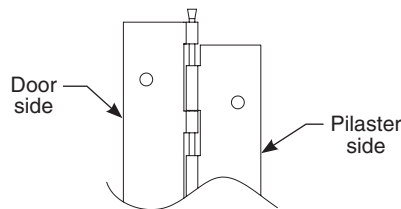

Part # Prefix HDWT-S0208  
(right hand in, left hand out, knuckles facing front)

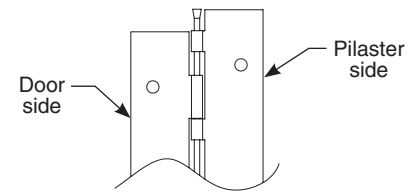

**A** Place door on a 12" (305mm) spacer and set the door gaps. Standard hinge side gap is 3/16" (5mm).

**B** Position the hinge so it is plumb and centered within the 3/16" (5mm) gap and centered top to bottom (approximately 1/4" (6mm) down from the top of the door).

**C** Using the hinge as a template, drill Ø1/4" holes through the door at the top and bottom holes. Secure the hinge to the door using the #10-24 x 1/2" barrel nuts and #10-24 x 1/2" shoulder screws provided.

**D** Verify the hinge side gap is still at 3/16" (5mm). Using the hinge as a template, drill Ø1/4" holes through the pilaster at the top and bottom holes. Secure the hinge to the pilaster using the #10-24 x 1/2" barrel nuts and #10-24 x 1/2" shoulder screws provided.

**E** Using the hinge as a template, drill Ø1/4" holes for all remaining hinge holes through both the door and pilaster. Secure hinge with fasteners provided.

**Closed Door View**

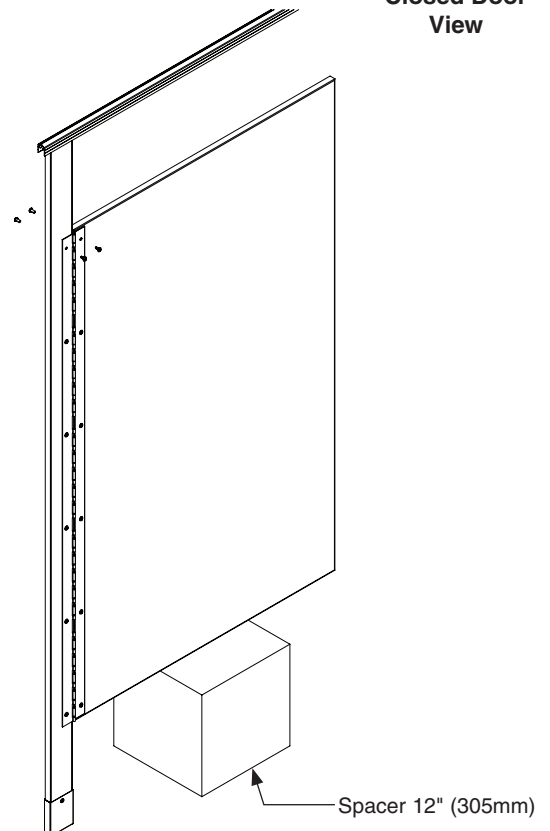

**10 Door Hardware for Inswing Doors - Surface**

 Local codes vary from state to state. Check your local codes before installing the coat hook and door pulls.

**A** Position latch centered top to bottom and with the leading edge 1/8" (3mm) from the door edge. Using the latch as a template, mark the hole locations and drill Ø11/64" pilot holes, 5/8" (16mm) deep. Secure latch to door with the #10 x 5/8" screws provided.

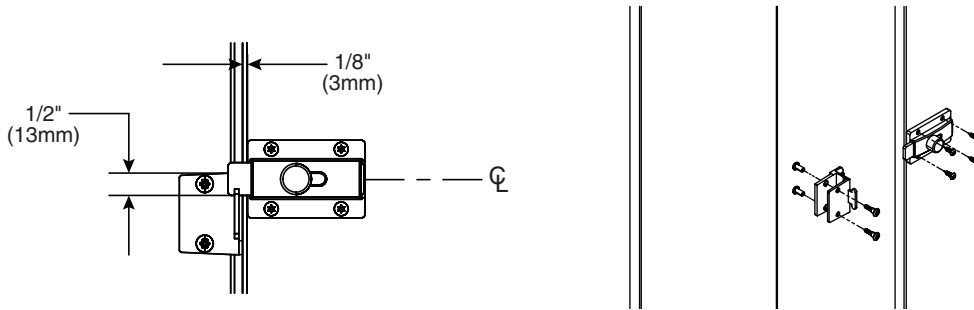

**B** With the door in the closed position, position the strike/keeper on the pilaster and align the top so it is 1/2" (13mm) above the bottom of the latch slide bar. Using the strike/keeper as a template, mark the hole locations and drill Ø1/4" holes through the pilaster. Secure the strike/keeper to the pilaster with the #10-24 x 1/2" barrel nuts and #10-24 x 3/4" shoulder screws provided.

**C** For 34" - 36" doors, mark the location for the top hole on the inside face of the door 30-3/4" (781mm) up from the bottom of 58" tall doors (42-3/4" [1086mm] above finished floor) and 5-1/2" (140mm) from the door edge. Drill (2) Ø1/4" holes (spaced 3-1/2" [89mm] apart) through the door and secure the door pulls to the door as shown with the #10-24 x 2" flat machine screws provided.

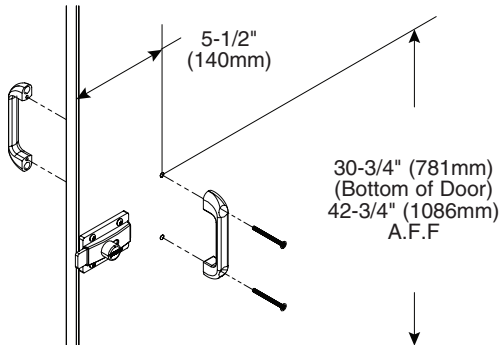

**D** Place the coat hook 3" (76mm) down from the top and 3" (76mm) from the latch side of the door (hook goes on the inside face of the door). Using the hook as a template, drill (2) Ø11/64" pilot holes, 5/8" (16mm) deep. Secure with the #10 x 5/8" screws provided.

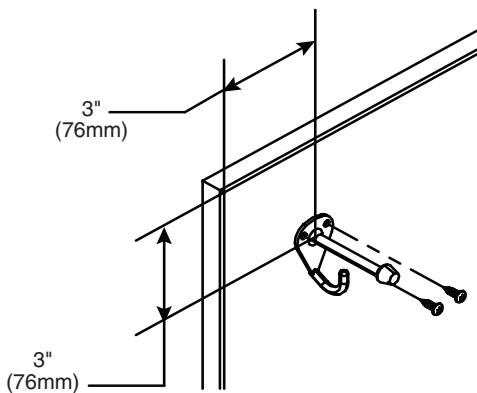

**Flat Strike/Keeper**

**E** With the door in the closed position, place flat strike/keeper so the latch slide bar fits within the slot.

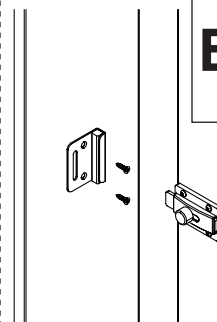

**F** Using the flat strike/keeper as a template, drill (2) Ø11/64" pilot holes, 5/8" (16mm) deep. Secure the flat strike/keeper to the pilaster using the #10 x 3/4" flat head screws provided.

**10a Door Hardware for Outswing Doors - Surface**

 Local codes vary from state to state. Check your local codes before installing the coat hook and door pulls.

**A** Position latch centered top to bottom and with the leading edge 5/8" (16mm) from the door edge. Using the latch as a template, mark the hole locations and drill Ø11/64" pilot holes, 5/8" (16mm) deep. Secure latch and spacer to door with the #10 x 1" screws provided.

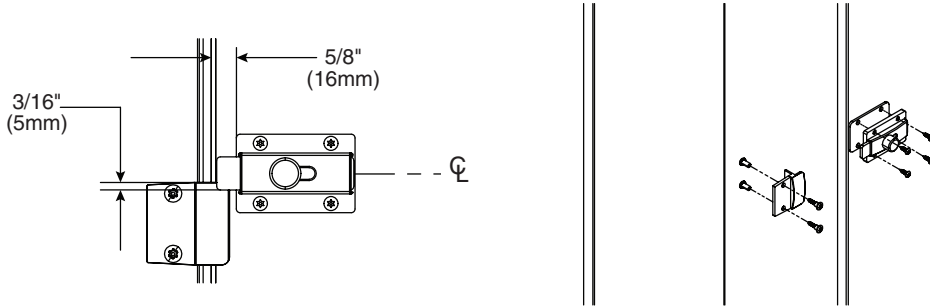

**B** With the door in the closed position, position the strike/keeper on the pilaster and align the top so it is a maximum of 3/16" (5mm) above the bottom of the latch slide bar. Using the strike/keeper as a template, mark the hole locations and drill Ø1/4" holes through the pilaster. Secure the strike/keeper to the pilaster with the #10-24 x 1/2" barrel nuts and #10-24 x 3/4" shoulder screws provided.

**C** Mark the location for the top hole on the inside face of the door 30-3/4" (781mm) up from the bottom of 58" tall doors (42-3/4" [1086mm] above finished floor) and 5-1/2" (140mm) from the door edge. Drill (2) Ø1/4" holes (spaced 3-1/2" [89mm] apart) through the door and secure the door pulls to the door as shown with the #10-24 x 2" flat machine screws provided.

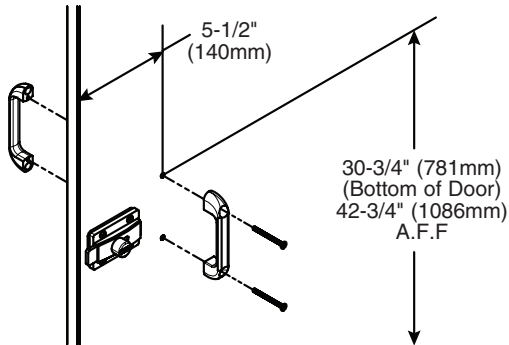

**D** Position the wall bumper 3" (76mm) up from the bottom and 3" (76mm) from the latch side of the door (bumper goes on the outside face of the door). Using the bumper as a template, drill (2) Ø11/64" pilot holes, 5/8" (16mm) deep. Secure to door with the #10 x 5/8" screws provided.

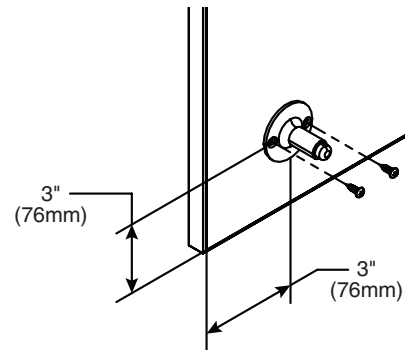

**Flat Strike/Keeper**

**F** With the door in the closed position, position the flat strike/keeper on the pilaster and align the top so it is 3/16" (5mm) above the bottom of the latch slide bar.

**G** Using the flat strike/keeper as a template, drill (2) Ø11/64" pilot holes, 5/8" (16mm) deep. Secure the flat strike/keeper to the pilaster using the #10 x 3/4" flat head screws provided.

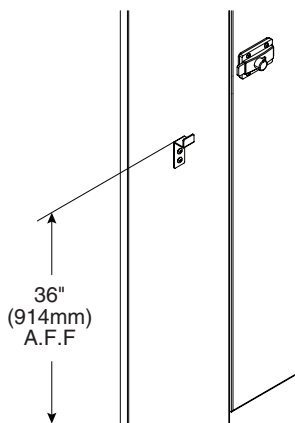
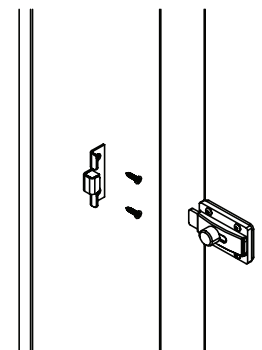

**E** Position the coat hook 36" (914mm) above finished floor (hook goes on the inside of compartment). Using the hook as a template, drill (2) Ø15/64" pilot holes, 5/8" (16mm) deep. Secure with the #14 x 5/8" screws provided.

### 11 Urinal Screens with Stirrup Brackets (Standard)

 Before installing the urinal screen components, determine the correct location for your application

**A** Draw a plumb line on the wall to represent the urinal screen centerline. Measure from the highest point in the room and place a mark on the urinal screen centerline at dimensions "A", "B" and "C" for the respective urinal screen height (see table below).

**B** Position and center brackets at each mark and urinal screen centerline. Using the bracket as a template, mark the hole locations on the wall. Remove the bracket and drill a Ø5/16" hole (minimum 2" [51mm] deep) at each hole location.

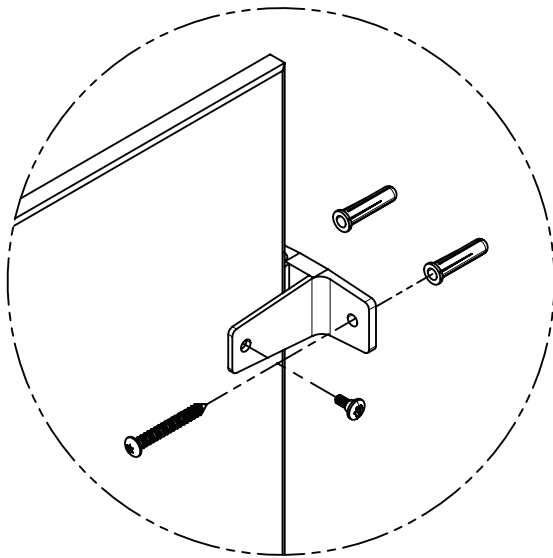

**C** Insert plastic anchors in all holes and secure bracket to the wall with the #14 x 2" screws provided.

**D** Place the urinal screen at dimension "D" for the respective urinal screen height (see table on right) and insert it into the wall brackets until a 1" (25mm) gap between the wall and urinal screen is established.

**E** Using the bracket as a template, drill Ø1/4" holes through the urinal screen at each bracket hole. Secure the urinal screen to the brackets with the #10-24 x 1/2" barrel nuts and #10-24 x 1/2" shoulder screws provided.

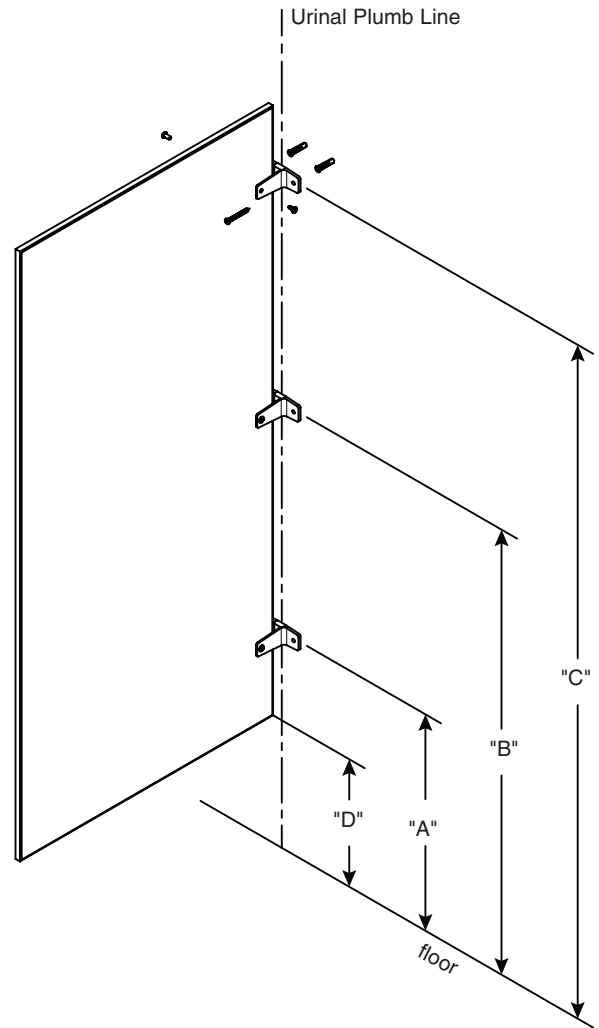

	Dim "A"	Dim "B"	Dim "C"	Dim "D"
42" Urinal Screen	24" (610mm)	39" (991mm)	54" (1372mm)	18" (457mm)
48" Urinal Screen	18" (457mm)	36" (914mm)	54" (1372mm)	12" (305mm)

**11a Urinal Screens with Continuous Stainless Steel Brackets (Optional)**

- Before installing the urinal screen components, determine the correct location for you application.
- Brackets are used as templates, but since the hole patterns may be different, the brackets may not be interchangeable.

**A** Draw a plumb line on the wall to represent the urinal screen centerline. Measure from the highest point in the room and place a mark on the urinal screen centerline at dimension "A" for the respective urinal screen height (see table below).

**B** Place the bottom of the bracket on the mark and center the opening on the urinal screen centerline. Using the bracket as a template, mark the hole locations on the wall. Remove the bracket and drill a  $\text{Ø}5/16"$  hole (minimum 2" [51mm] deep) at each hole location.

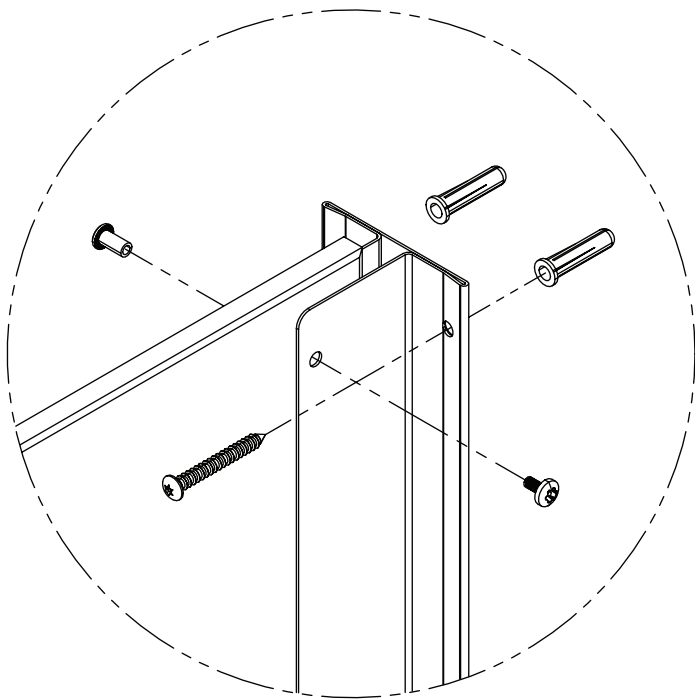

**C** Insert plastic anchors in all holes and secure bracket to the wall with the #14 x 2" screws provided.

**D** Place the urinal screen at dimension "B" for the respective urinal screen height (see table on right) and insert it into the wall bracket until a 1" (25mm) gap between the wall and urinal screen is established.

**E** Using the bracket as a template, drill  $\text{Ø}1/4"$  holes through the urinal screen at each bracket hole. Secure the urinal screen to the bracket with the #10-24 x 1/2" barrel nuts and #10-24 x 3/8" machine screws provided.

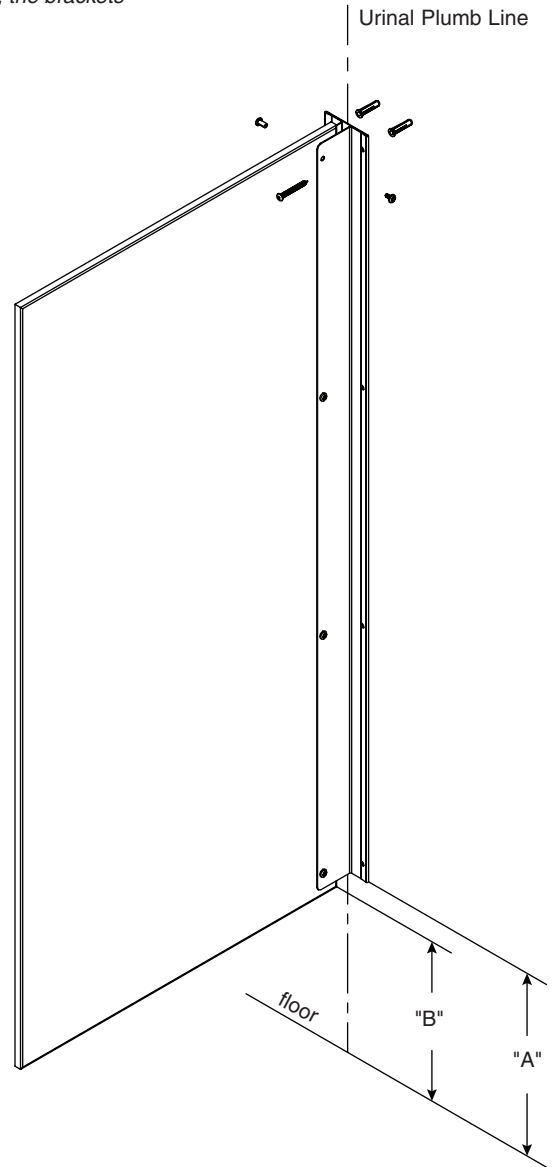

	Dim "A"	Dim "B"
42" Urinal Screen	18-1/2" (470mm)	18" (457mm)
48" Urinal Screen	12-1/2" (318mm)	12" (305mm)

**11b Urinal Screens with Continuous Aluminum Brackets (Optional)**

- Before installing the urinal screen components, determine the correct location for you application
- Brackets are used as templates, but since the hole patterns may be different, the brackets may not be interchangeable.

**A** Draw a plumb line on the wall to represent the urinal screen centerline. Measure from the highest point in the room and place a mark on the urinal screen centerline at dimension "A" for the respective urinal screen height (see table below).

**B** Place the bottom of the bracket on the mark and center the opening on the urinal screen centerline. Using the bracket as a template, mark the hole locations on the wall. Remove the bracket and drill a Ø5/16" hole (minimum 2" [51mm] deep) at each hole location.

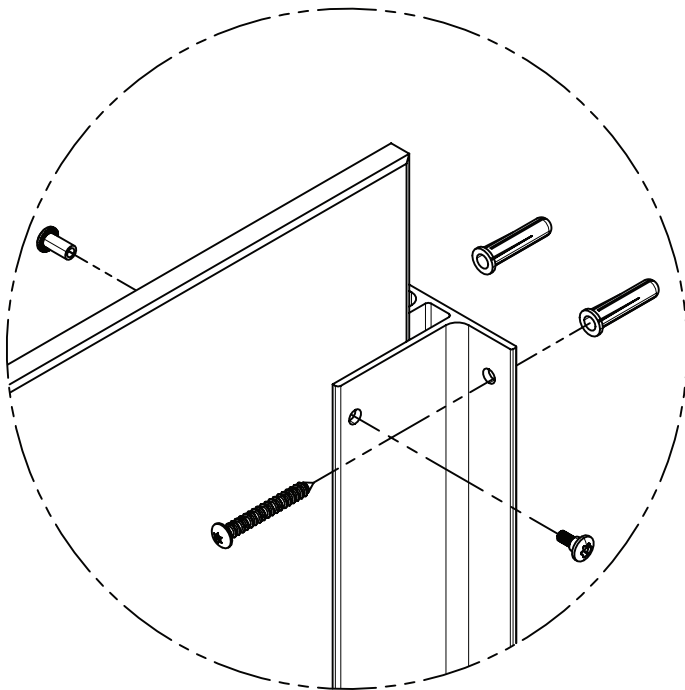

**C** Insert plastic anchors in all holes and secure bracket to the wall with the #14 x 2" screws provided.

**D** Place the urinal screen at dimension "B" for the respective urinal screen height (see table on right) and insert it into the wall bracket until a 1" (25mm) gap between the wall and urinal screen is established.

**E** Using the bracket as a template, drill Ø1/4" holes through the urinal screen at each bracket hole. Secure the urinal screen to the bracket with the #10-24 x 1/2" barrel nuts and #10-24 x 1/2" shoulder screws provided.

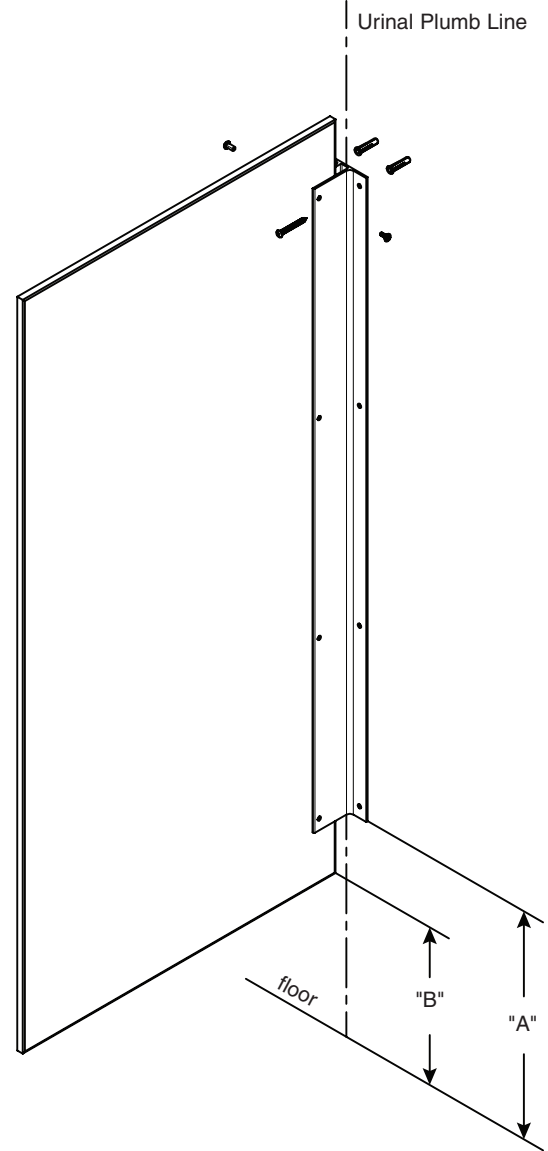

	Dim "A"	Dim "B"
42" Urinal Screen	18-1/4" (464mm)	18" (457mm)
48" Urinal Screen	15-1/4" (387mm)	12" (305mm)