

Installation

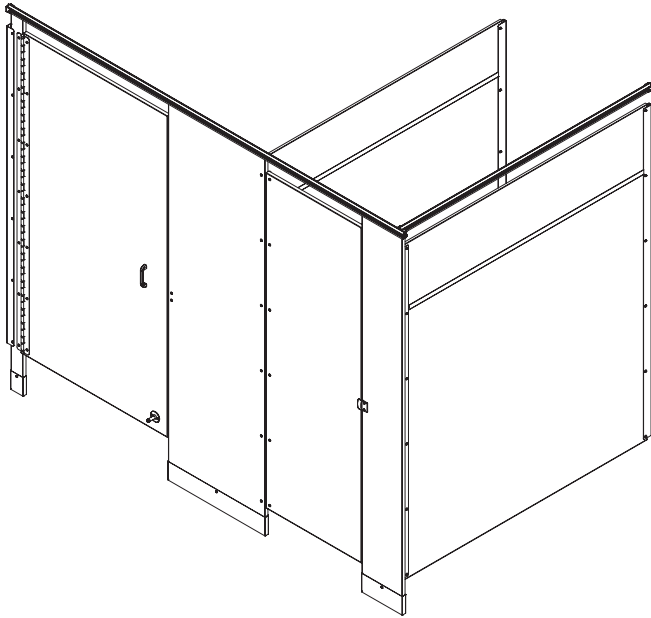

**For 69" and 72" Tall
Doors and Panels Only**

Phenolic Restroom Partitions Floor-Mounted with Overhead Brace Series 400

Table of Contents

Pre-Installation Information	2-3
Layout Dimensions for Brackets	4
Mounting Brackets to Wall	4
Leveling Screws to Pilaster	5
Mounting Brackets to Pilaster	5-6
Pilaster Mounting Hardware	6
Pilasters and Panels	7-8
Wall-Hung Pilasters	9-10
Pilaster Shoes	11
Headrail	12
Hinges	13-14
Door Hardware	15-16
Urinal Screens	17



Read the instructions in this manual before beginning installation. Save these instructions and refer to them for inspection, maintenance and troubleshooting information.

For questions regarding the operation, installation or maintenance of this product, visit bradleycorp.com or call 800.BRADLEY (800.272.3539).

Product warranties and parts information may also be found on our website at bradleycorp.com.



Safety Information

To ensure proper operation:

Installation

Failure to comply with these instructions may result in personal injury and/or property damage and will void the partition warranty.

Personal protective equipment (PPE) is required during the installation and maintenance of this product.

Compliance and conformity to local codes and ordinances is the responsibility of the installer.

Before beginning installation, make sure that the wall and floor backing are adequate to support the secure mounting of the toilet compartment units.

Make sure all floors and walls are clean and smooth. Remove loose impediments, such as protruding nails and other debris which could affect installation.

Review your partition layout drawings and verify the number of stalls and components before beginning installation.

This installation manual provides instruction for the assembly of normal partition configurations and standard components. Non-standard configurations or components including but not limited to curved or angled walls, partial walls, oversized panels, or modified hardware are not covered in this manual.

To avoid product or property damage:

Carefully remove components from skid, do not drag.

To prevent warping, always lay the material flat. Do not lean the material against the wall or stack unevenly.

To minimize break-out, always use a support block when drilling through the material.

Supplies Required

- Chalk line and pencil
- Tape measure and 4' level
- Jigsaw (or hacksaw) and circular saw
- Two spring clamps
- 11/64", 15/64", 7/32", 1/4" and 17/64" drill bits
- Power drill or screw gun with drill bit extension
- 5/16" ceramic tile and masonry drill bit
- Hammer drill
- Spacers, 6" (152mm) and 9" (229mm) high and strong enough to support weight of panel

Hardware Provided

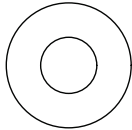

9/32" x 5/8"
Washer Flat
P10-449

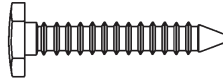

5/16" x 1-1/2"
Hex Head
Lag Screw
FAST-S008



#14-16 Plastic
Anchor
FAST-T373

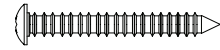

#14 x 2"
Button-Head
Sheet Metal Screw
Torx-T27 Drive
FAST-P002



#14 x 5/8"
Button-Head
Sheet Metal Screw
Torx-T27 Drive
FAST-S0016



#10 x 5/8"
Button-Head
Sheet Metal Screw
Torx-T27 Drive
FAST-S0019



#10 x 1"
Button-Head
Sheet Metal Screw
Torx-T27 Drive
FAST-S0028



#10 x 3/4"
Flat-Head
Sheet Metal Screw
Torx-T25 Drive
FAST-S0006



#10-24 x 3/8"
Button-Head
Machine Screw
Torx-T27 Drive
FAST-S0015



#10-24 x 1/2"
Button-Head
Shoulder Screw
Torx-T27 Drive
FAST-S0018



#10-24 x 3/4"
Button-Head
Shoulder Screw
Torx-T27 Drive
FAST-P004



#10-24 x 1"
Button-Head
Shoulder Screw
Torx-T27 Drive
FAST-P004A



#10-24 x 1/2"
Button-Head
Barrel Nut
Torx-T27 Drive
FAST-S0017



#10-24 x 2"
Flat-Head
Machine Screw
Torx-T25 Drive
FAST-S0027

Example of Submittal Drawing

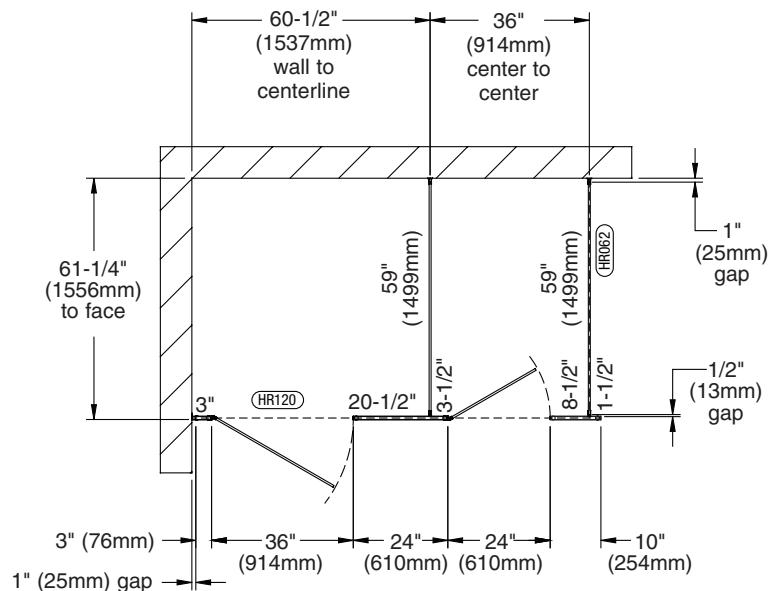

1 Layout Dimensions - Continuous Brackets

When installing the partition components, consult the applicable Mills Partition submittal drawing for compartment layout dimensions.

1. Pilaster Centerline: Measure from the back wall forward to the face of the compartment, subtract 3/8" (10mm) and mark this location on the floor ("A"). Mark the same measurement on the opposite end of your layout ("A1") and draw a straight line connecting both marks.

For Freestanding (FS) Partitions: Refer to submittal drawings and determine the approximate location of the outside panels. Establish dimensions "A" and "A1" as explained above.

2. Panel Centerline: Measure the stall width across the back wall and place a mark at the base of the rear wall ("B"). Repeat this step for each panel, starting each measurement from the last panel centerline ("B1").
3. Draw a plumb line on all walls from each pilaster and panel centerline. From the highest point in the room, measure from the floor and place a mark on the pilaster/panel plumb line at dimension "C". Use a level to transfer that mark to all other plumb lines ("C").

In ADA stalls, using "C" as a reference point, measure up 3" to locate the "D" dimension (see table).

	A.F.F.	Bracket Height
Dim "C"	6-1/2" (165mm)	71" (1803mm)
Dim "D" (ADA Stall)	9-1/2" (241mm)	68" (1727mm)

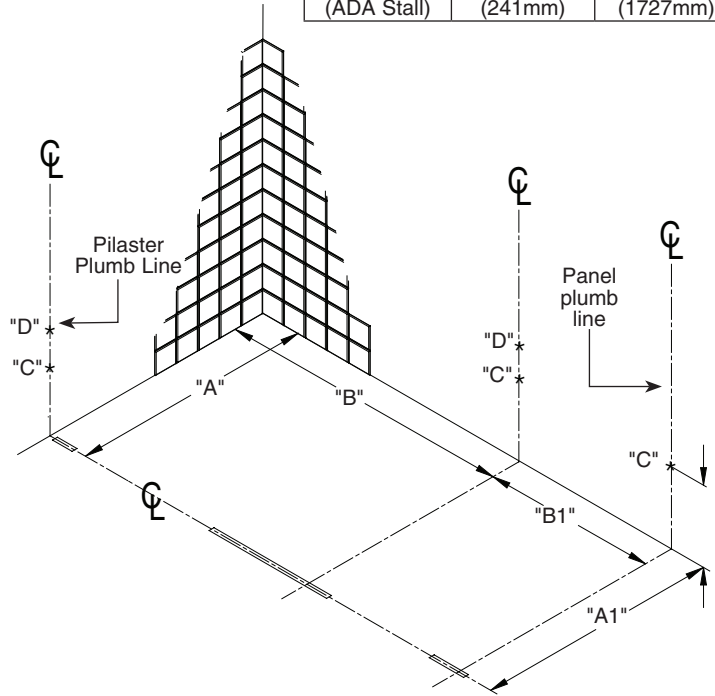

2 Continuous Stainless Steel Brackets to Wall

- On pilaster applications, position the bracket with the ear facing toward the inside of the stall.
- Pilaster bracket shown here; "EAR" brackets are for pilasters and "U" brackets are for panels.
- Brackets are used as templates, but since the hole patterns may be different, the brackets may not be interchangeable.

1. Place the bottom of each continuous bracket at the established level line. Center the bracket opening on the pilaster/panel plumb line.
2. Using the bracket as a template, mark the hole locations on the wall. Remove the bracket and drill a Ø5/16" hole (min. 2" [51mm] deep) at each hole location.
3. Insert the plastic anchors in all holes and secure the brackets to the wall with the #14 x 2" screws provided.

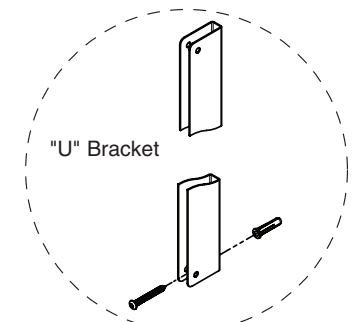
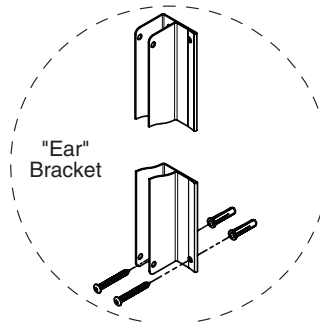
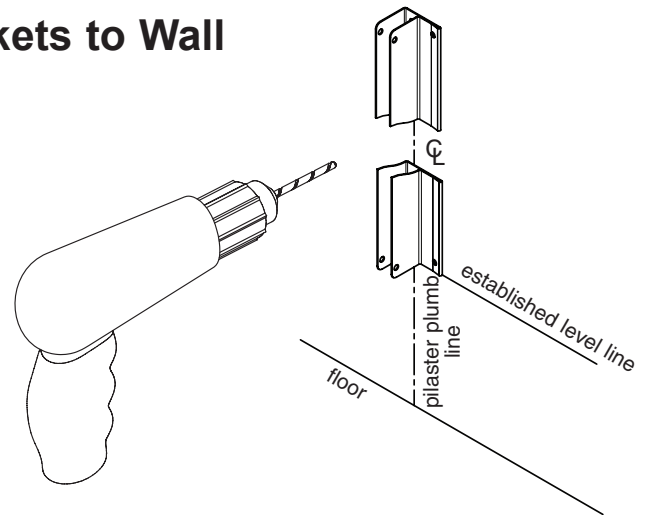

3 Leveling Screws to Pilaster

When pilasters are pre-drilled (optional), a notch will be present on one end of the pilaster to indicate that it is the bottom.

1. 3" - 16" Pilaster: Center and drill a $\text{Ø}17/64$ " pilot hole, 1-1/2" (38mm) deep.

18" - 24" Pilaster: Drill (2) $\text{Ø}17/64$ " pilot holes, 1-1/2" (38mm) deep. Holes should be 2" (51mm) off each end of the pilaster.
2. Use leveling screw(s) to adjust height of pilaster as indicated based on pilaster width.

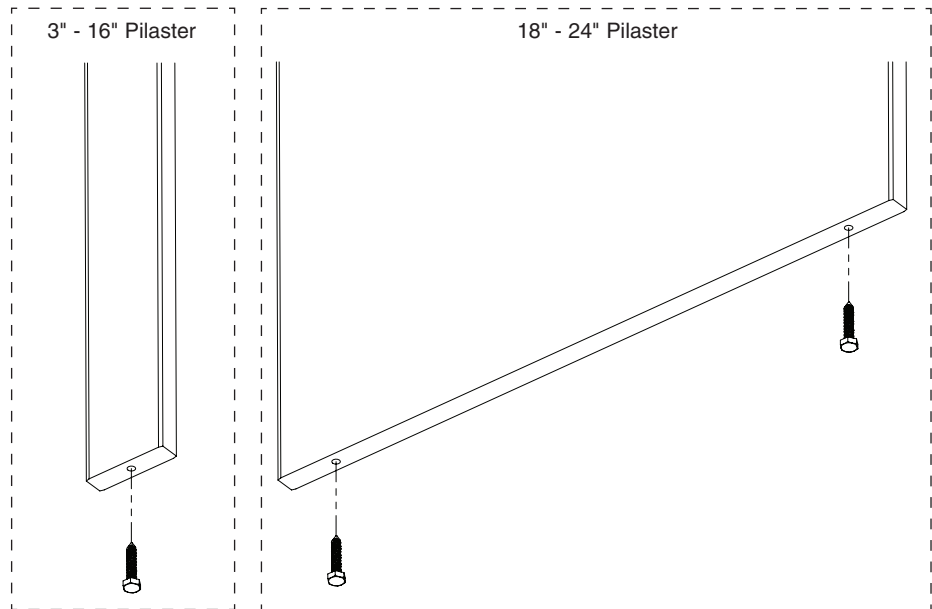

4 Continuous Brackets to Pilaster

- Refer to the submittal drawing to locate the split dimension and layout location of each marked pilaster.
- Brackets are used as templates, but since the hole patterns may be different, the brackets may not be interchangeable.
- Pilaster shown is for reference only. Actual pilaster varies depending on application.

	Dim. "A"	Dim. "B"
69" Pilaster (ADA)	4" (102mm)	72" (1829mm)
72" Pilaster (Standard)	4" (102mm)	75" (1905mm)

1. Measure down from the top of the pilaster and place a mark on the pilaster centerline at dimensions "A" and "B" for the respective bracket (see table).
2. Place the continuous bracket between each established level line. Center the bracket opening on the pilaster split centerline. Using the bracket as a template, mark the hole locations on the pilaster. Remove the bracket and drill a $\text{Ø}15/64$ " pilot hole, 5/8" (16mm) deep at each location.
3. Secure the continuous bracket to the pilasters using the #14 x 5/8" screws provided.

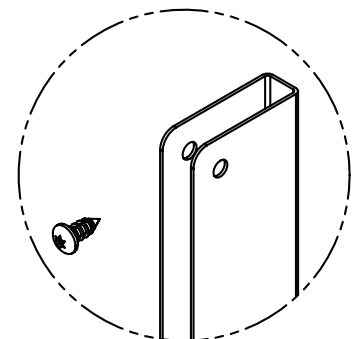
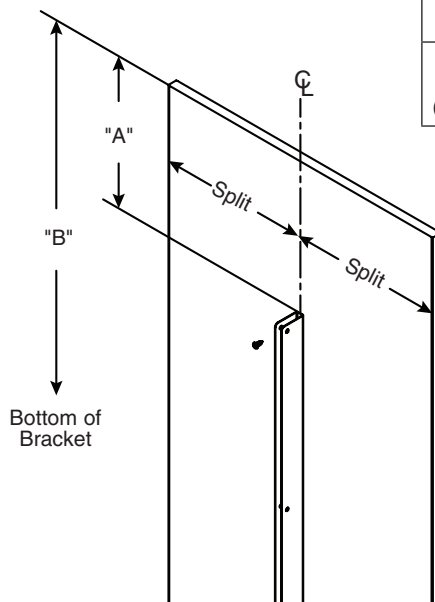

4a Alcove Brackets to Pilaster

 Refer to the submittal drawing for the layout location of each alcove pilaster

1. Measure down from the top of the pilaster and place a mark at dimensions shown for the respective bracket situation.
2. Center the bracket between each mark made in Step 1.
3. Using the bracket as a template, mark the hole locations on the pilaster. Remove the bracket and drill $\text{Ø}1/4"$ holes through the pilaster at each location.
4. Secure the brackets to the pilaster using the #10-24 x 1/2" barrel nuts and #10-24 x 1/2" shoulder screws provided.

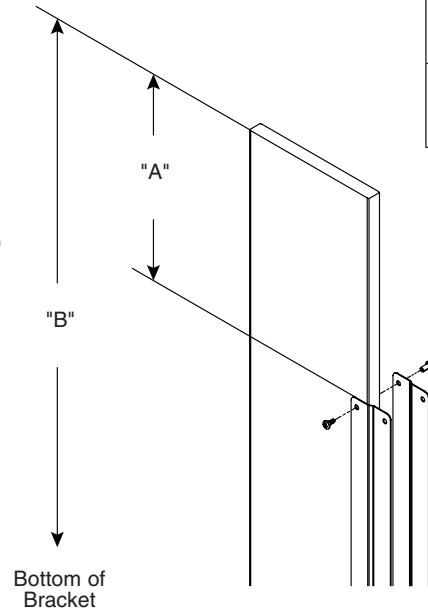

	Dim. "A"	Dim. "B"
69" Pilaster (ADA)	4" (102mm)	72" (1829mm)
72" Pilaster (Standard)	4" (102mm)	75" (1905mm)

5 Pilaster Mounting Hardware

1. Starting with the pilaster closest to the wall, measure and mark the pilaster and door widths on the pilaster centerline. Make sure to leave the appropriate gap between the wall and the pilaster. Place corresponding shoe on the pilaster centerline and center between the marks.

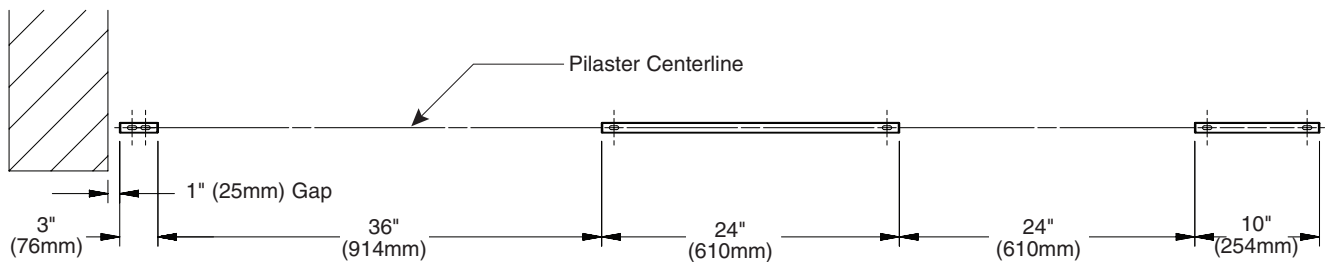

 This view is an example only; refer to your submittal drawings for actual sizes.

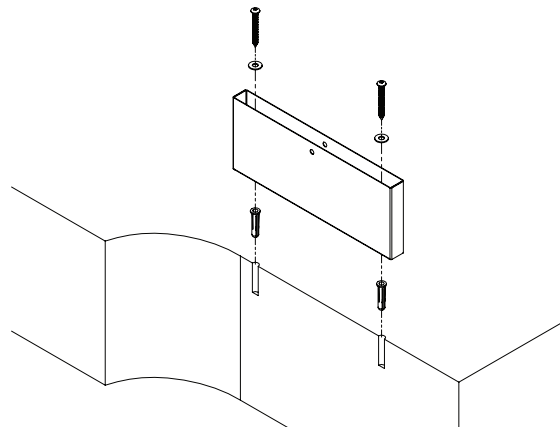

2. Using the shoe as a template, mark the hole locations on the floor. Remove the shoe and drill $\text{Ø}5/16"$ holes (min 2" [51mm] deep) into the floor. Make sure the holes are free of dirt and debris.
3. Insert plastic anchors into the holes and secure the shoe to the anchors using the 9/32" x 5/8" flat washer and #14 x 2" screws provided.



6 Pilasters and Panels with Stainless Steel Continuous Brackets

- 
Pilasters located at walls should be mounted first. Start at one end and install a panel, then a pilaster. Continue alternating until installation is complete. When installing in an alcove or in-corner, use an alcove bracket to secure the pilaster to the panel.
- 
Check to make sure the pilasters are plumb and level to each other. The pilaster height can be adjusted with the leveling screw that was placed at the bottom of the pilaster (see page 5 for attaching leveling screw).

Pilasters at Wall

- 
When installing pilasters at walls, the gaps range from 1/2" to 1-1/4" (13mm to 32mm). Refer to your submittal drawing for your gap sizes.

1. Place the pilaster within the shoe while at the same time placing it within the wall bracket.
2. Using the bracket as a template, drill $\text{Ø}1/4"$ holes through the pilaster at each pilaster bracket hole. Secure the pilaster to the bracket using the #10-24 x 1/2" barrel nuts and #10-24 x 1/2" shoulder screws provided.

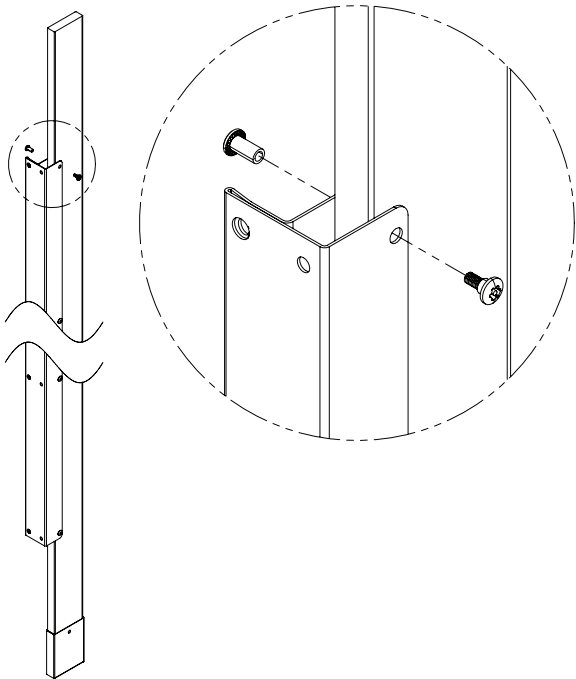

Pilasters with Panels (Single Panel)

- 
Refer to your submittal drawing and leave the appropriate gaps. Standard gap is 1" (25mm) between the panel and wall and 1/2" (13mm) between the panel and pilaster.

1. Place the panel on the spacer and insert the panel into the wall bracket.
2. Place the pilaster within the shoe while at the same time placing the bracket around the panel.
3. Using the bracket as a template, drill $\text{Ø}1/4"$ holes through the panel at each panel bracket hole. Secure the panel to the bracket using the #10-24 x 1/2" barrel nuts and #10-24 x 3/8" machine screws provided.

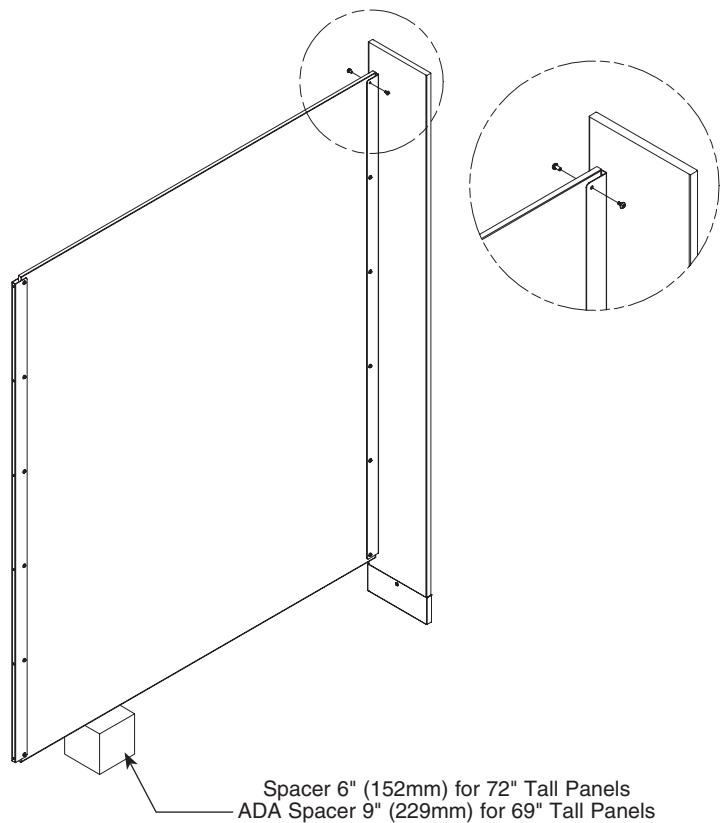

6a Pilasters and Panels with Stainless Steel Continuous Brackets

Check to make sure the pilasters are plumb and level to each other. The pilaster height can be adjusted with the leveling screw that was placed at the bottom of the pilaster (see page 5 for attaching leveling screw).

Pilasters with Panels (Stacked Panels - Bottom)

Refer to your submittal drawing and leave the appropriate gaps. Standard gap is 1" (25mm) between the panel and wall and 1/2" (13mm) between the panel and pilaster.

1. Place the panel on the spacer and insert the panel into the wall bracket.
2. Place the pilaster within the shoe while at the same time placing the bracket around the panel.
3. Using the bracket as a template, drill $\varnothing 1/4"$ holes through the bottom panel at each panel bracket hole. Secure the panel to the bracket using the #10-24 x 1/2" barrel nuts and #10-24 x 3/8" machine screws provided.

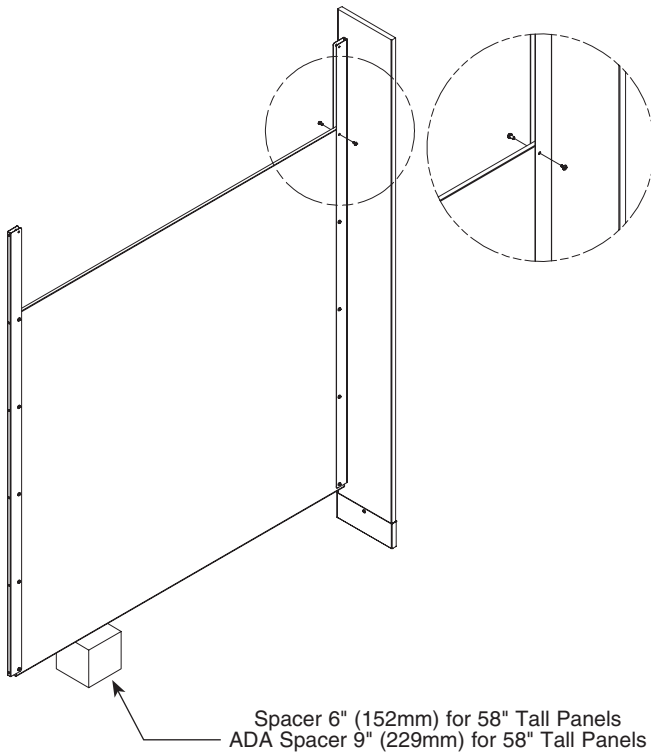

Pilasters with Panels (Stacked Panels - Top)

Refer to your submittal drawing and leave the appropriate gaps. Standard gap is 1" (25mm) between the panel and wall and 1/2" (13mm) between the panel and pilaster.

4. Cut the "H" bracket to fit between the "U" brackets and place onto the bottom panel. Place top panel into "H" and "U" brackets as shown.
5. Using the bracket as a template, drill $\varnothing 1/4"$ holes through the top panel at each panel bracket hole. Secure the panel to the bracket using the #10-24 x 1/2" barrel nuts and #10-24 x 3/8" machine screws provided.

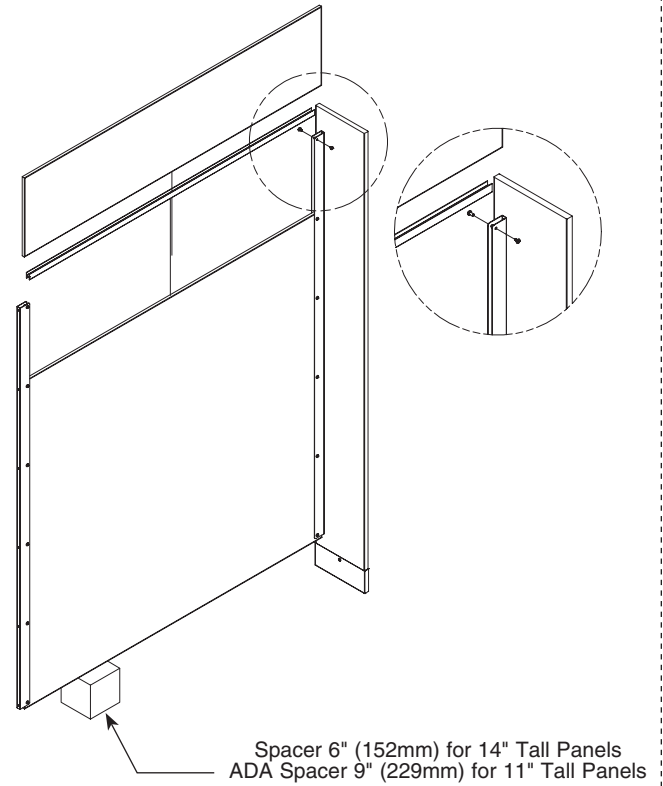

6b Wall-Hung Pilasters (69" or 72-3/8") - Continuous Stainless Steel Brackets (Used with 69" Tall Door)

- ✓ See Step 2 for instructions on mounting the continuous stainless steel brackets to a wall.
- ✓ See Step 4 for instructions on mounting the continuous stainless steel brackets to a pilaster.
- ✓ To establish level line, from the highest point in the room, measure 9" (229mm) from the floor. Use a level to transfer this mark to the pilaster plumb line.
- ✓ Pilasters shown in (2) different lengths for visual reference.

Pilasters at Wall

1. Slide the wall-hung pilaster into the continuous bracket and align with the established level line. Refer to the submittal drawing and adjust to meet the specified dimension.
2. Using the bracket as a template, drill $\text{Ø}1/4"$ holes through the pilaster at each pilaster bracket hole. Secure the pilaster to the bracket using the #10-24 x 1/2" barrel nuts and #10-24 x 1/2" shoulder screws provided.

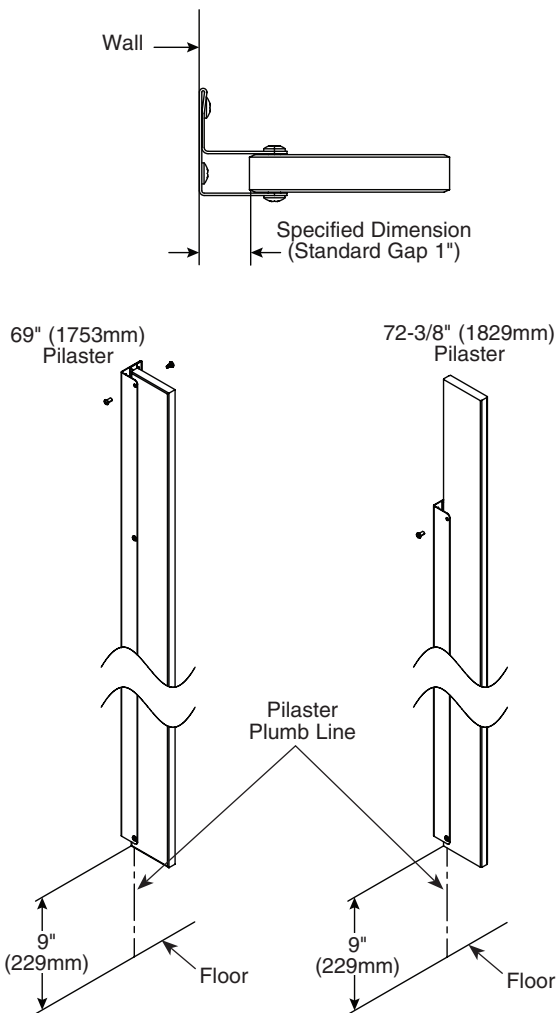

Pilasters at Pilasters

1. Slide the wall-hung pilaster into the continuous bracket and align with the established level line. Refer to the submittal drawing and adjust to meet the specified dimension.
2. Using the bracket as a template, drill $\text{Ø}1/4"$ holes through the pilaster at each pilaster bracket hole. Secure the pilaster to the bracket using the #10-24 x 1/2" barrel nuts and #10-24 x 1/2" shoulder screws provided.

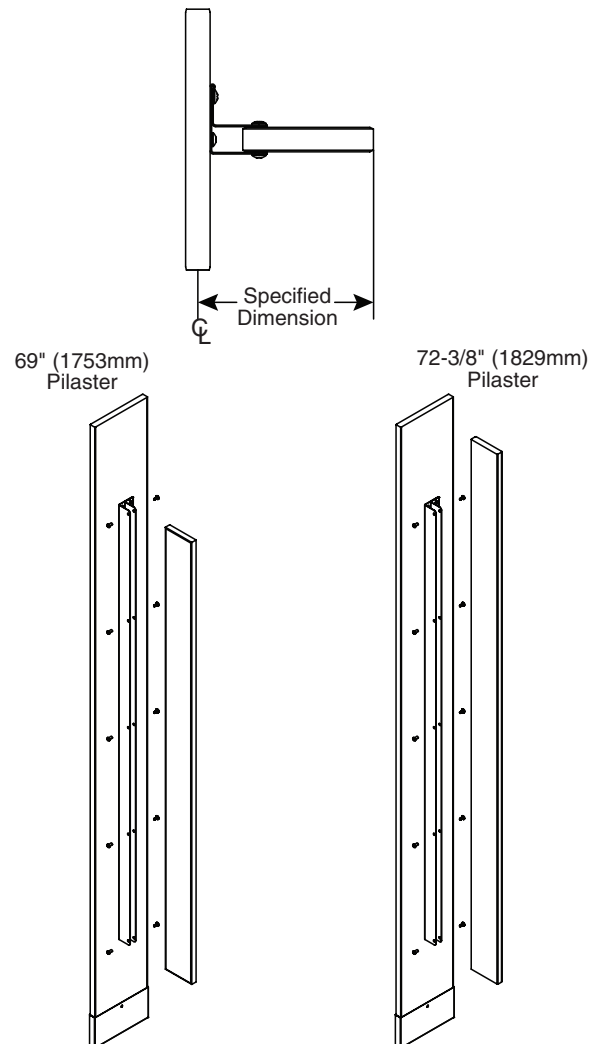

6c Wall-Hung Pilasters (72" or 75-3/8") - Continuous Stainless Steel Brackets (Used with 72" Tall Door)

- See Step 2 for instructions on mounting the continuous stainless steel brackets to a wall.
- See Step 4 for instructions on mounting the continuous stainless steel brackets to a pilaster.
- To establish level line, from the highest point in the room, measure 6" (152mm) from the floor. Use a level to transfer this mark to the pilaster plumb line.
- Pilasters shown in (2) different lengths for visual reference.

Pilasters at Wall

- Slide the wall-hung pilaster into the continuous bracket and align with the established level line. Refer to the submittal drawing and adjust to meet the specified dimension.
- Using the bracket as a template, drill $\text{\O}1/4"$ holes through the pilaster at each pilaster bracket hole. Secure the pilaster to the bracket using the #10-24 x 1/2" barrel nuts and #10-24 x 1/2" shoulder screws provided.

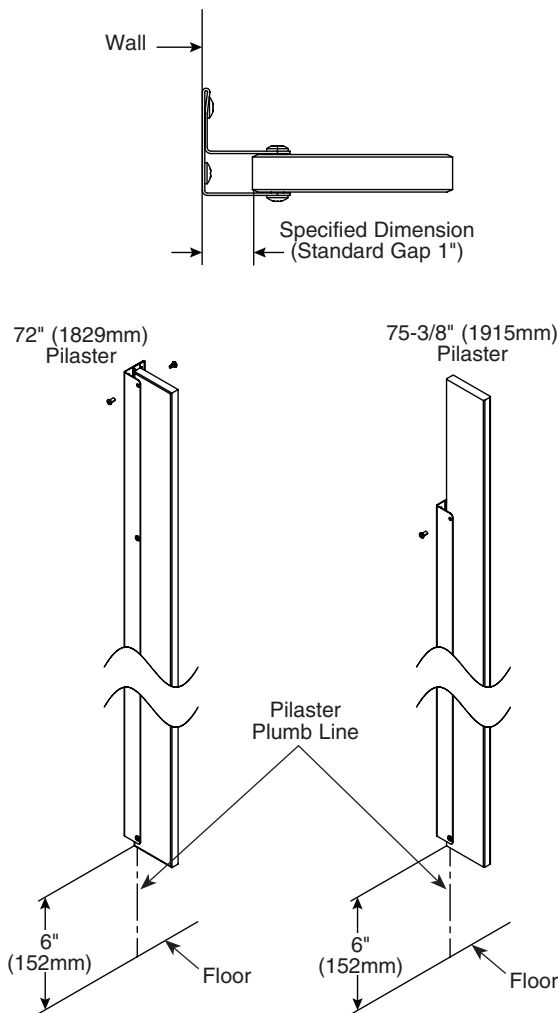

Pilasters at Pilasters

- Slide the wall-hung pilaster into the continuous bracket and align with the established level line. Refer to the submittal drawing and adjust to meet the specified dimension.
- Using the bracket as a template, drill $\text{\O}1/4"$ holes through the pilaster at each pilaster bracket hole. Secure the pilaster to the bracket using the #10-24 x 1/2" barrel nuts and #10-24 x 1/2" shoulder screws provided.

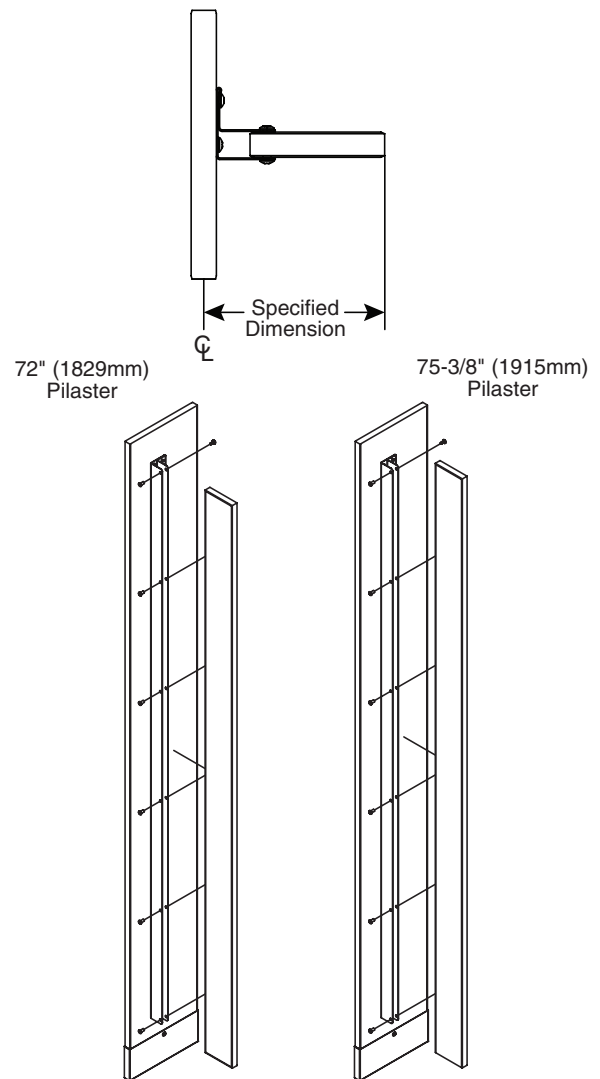

7 Pilaster Shoes

1. Using the hole in the shoe as a template, drill a $\text{Ø}1/4$ " hole through the pilaster.
2. Secure the pilaster to the shoe using the #10-24 x $1/2$ " barrel nut and #10-24 x $3/4$ " shoulder screw provided.

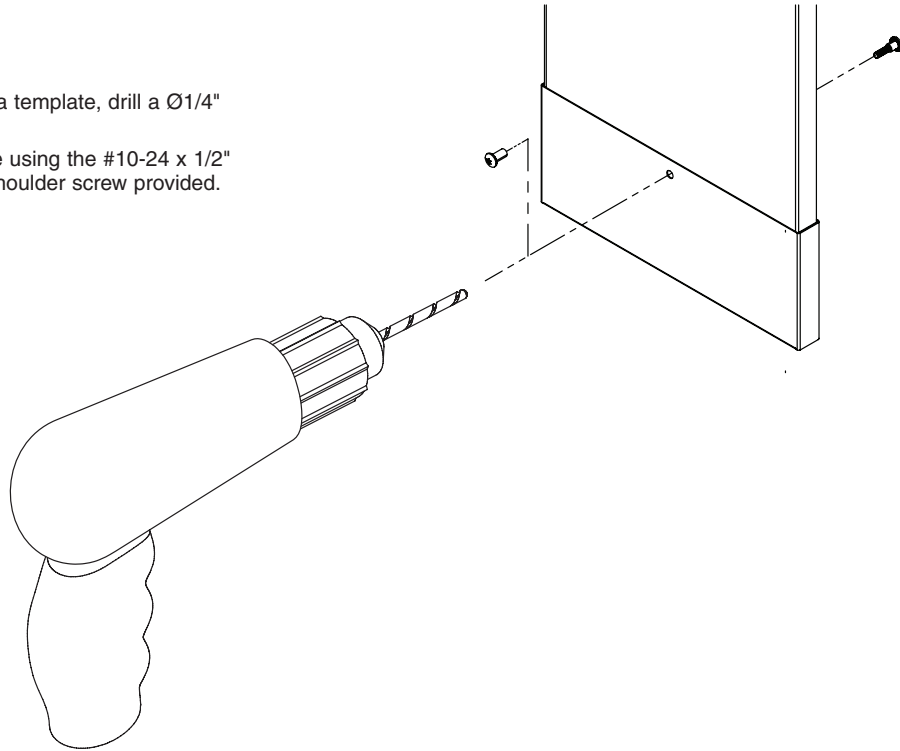

8 Headrail

- ✓ *Make sure the pilasters are plumb and that the pilaster has been secured to the shoe. Leave the appropriate door opening between the pilasters as shown on your submittal drawing.*
- ✓ *The illustrations on this page show mounting hardware and fasteners for a generic application. Refer to your submittals to determine your actual headrail configurations.*
- ✓ *Some headrail sections may need to be cut to an appropriate size. Refer to your submittals for general headrail placement.*
- ✓ *Headrail configurations that come to an intersection should meet over a pilaster (see completed headrail assembly view below).*

1. Place headrail over the top of each pilaster located at the wall and slide it tight against the side wall. Mark the outline of the headrail on the wall and remove the headrail.

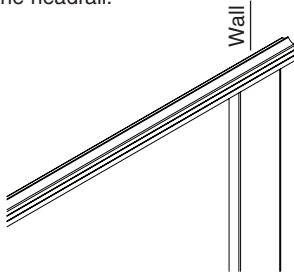

2. Place the headrail bracket on the outline marked on the wall and mark the locations of the mounting holes. Remove bracket and drill (2) Ø5/16" holes a minimum of 2" (51mm) deep. Prior to securing to the wall, enlarge the (2) back mounting holes of the bracket to Ø1/4". Secure the bracket to the wall with the #14 x 2" screws and plastic anchors provided.

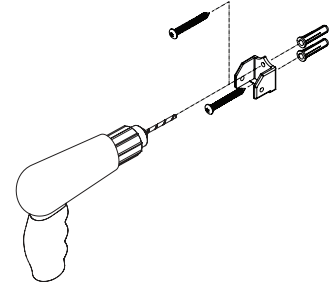

3. Place headrail over the top of the pilasters and slide it tight into the mounting bracket. Use the mounting bracket as a template and drill a Ø7/32" hole through the headrail. Secure the headrail to the mounting bracket with the #10 x 5/8" screws provided.

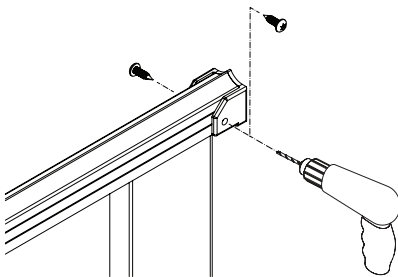

4. Make sure the pilaster is plumb and that the spacing between the pilasters for the doors is the correct dimension. On the back of each pilaster (starting with the first pilaster), drill a Ø7/32" hole through one face of the headrail only.

Using this hole as a template, drill a Ø11/64" pilot hole into the pilaster, 5/8" (16mm) deep. Secure the headrail to the back of each pilaster with the #10 x 5/8" screws provided.

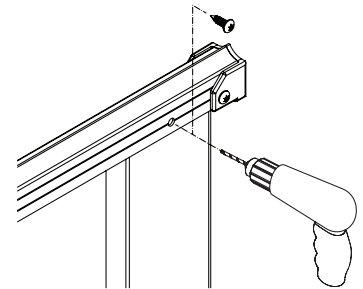

5. For open end applications, cut the headrail to the appropriate length (if required). Attach the bracket to the wall at the correct height (see Step 2). Attach another bracket to a pilaster with #10 x 5/8" screws at the correct height (see view below). The headrail should be level with any adjacent headrail and should be located directly over the panel. Position each headrail onto the brackets and secure with required fasteners (see Step 3). Using a rubber mallet, install the headrail end cap.

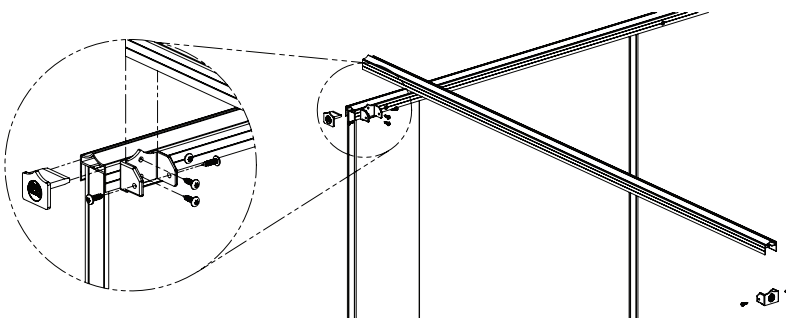

Completed Headrail Assembly

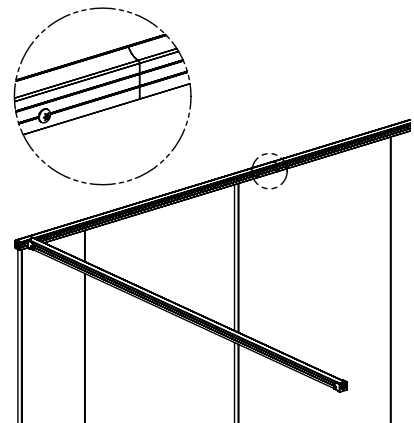

9 Continuous Spring-Loaded Piano Hinge

- ✓ Before installing the hinges, make sure the door openings are the appropriate size, all pilasters are plumb and secured to the shoe, and that the headrail is installed.
- ✓ Refer to your submittal drawings to determine each specific door swing for your application. The door swing is determined by facing the compartment from the outside. The image below can help determine the door swing type.

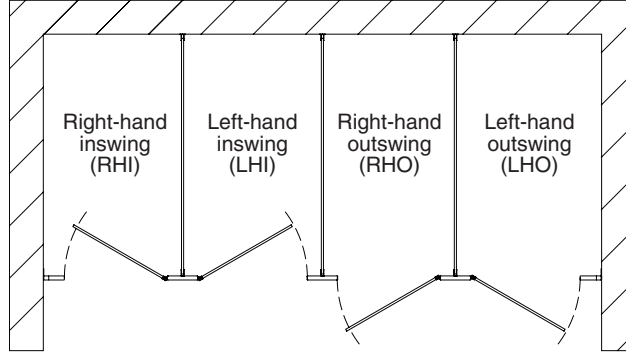

<p>Continuous Piano Hinge</p> <p>The part numbers listed are for hinges only and are used to determine the door swing as shown above. Inswinging doors should have hinges mounted on the inside of the stall while outswinging doors should have hinges mounted on the outside of the stall.</p>	<p>Part # HDWT-S0472 (68-1/2") HDWT-S0408 (71-1/2") (left hand in, right hand out, knuckles facing front)</p> <p>Door side — Pilaster side</p>	<p>Part # HDWT-S0471 (68-1/2") HDWT-S0407 (71-1/2") (right hand in, left hand out, knuckles facing front)</p> <p>Door side — Pilaster side</p>
---	--	--

1. Place door on a 6" (152mm) spacer (9" (229mm) spacer for ADA) and set the door gaps. Standard hinge side gap is 3/16" (5mm).
2. Position the hinge so it is plumb and centered within the 3/16" (5mm) gap and centered top to bottom (approximately 1/4" (6mm) down from the top of the door).
3. Using the hinge as a template, drill Ø1/4" holes through the door at the top and bottom holes. Secure the hinge to the door using the #10-24 x 1/2" barrel nuts and #10-24 x 1/2" shoulder screws provided.
4. Verify the hinge side gap is still at 3/16" (5mm). Using the hinge as a template, drill Ø1/4" holes through the pilaster at the top and bottom holes. Secure the hinge to the pilaster using the #10-24 x 1/2" barrel nuts and #10-24 x 1/2" shoulder screws provided.
5. Using the hinge as a template, drill Ø1/4" holes for all remaining hinge holes through both the door and pilaster. Secure hinge with fasteners provided.

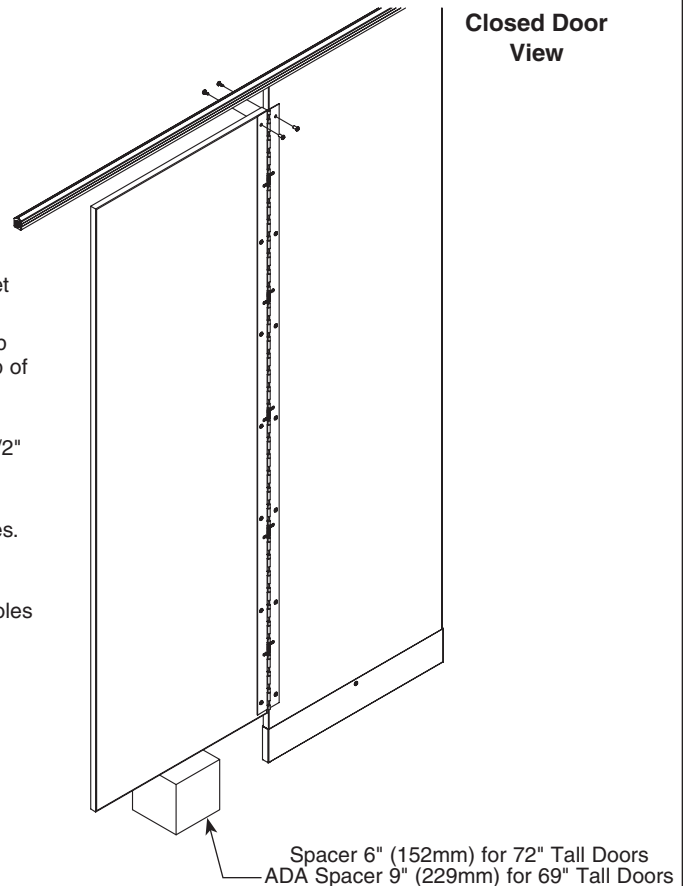

9a Continuous Cammed Piano Hinge (Optional)

- ✓ Before installing the hinges, make sure the door openings are the appropriate size, all pilasters are plumb and secured to the shoe, and that the headrail is installed.
- ✓ Refer to your submittal drawings to determine each specific door swing for your application. The door swing is determined by facing the compartment from the outside. The image below can help determine the door swing type.

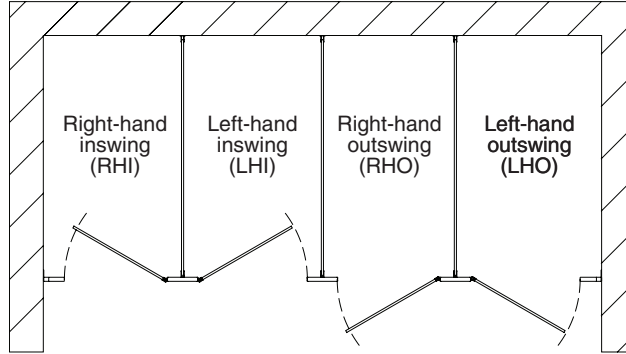

Inswing Standard: 20 Degrees
 Inswing ADA: 0 Degrees
 Outswing Standard: 0 Degrees
 Outswing ADA: 0 Degrees

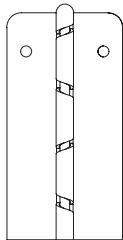
<p>Continuous Cammed Piano Hinge</p> <p>The part numbers listed are for hinges only and are used to determine the door swing as shown above. Inswinging doors should have hinges mounted on the inside of the stall while outswinging doors should have hinges mounted on the outside of the stall.</p>	<p>Part # HDWT-S0404-71 (71")</p> <p>(20 degrees open cam hinge, knuckles facing front)</p> 	<p>Part # HDWT-S0403-68 (68") HDWT-S0403-71 (71")</p> <p>(zero-degree open cam hinge, knuckles facing front)</p>
--	---	---

Closed Door View

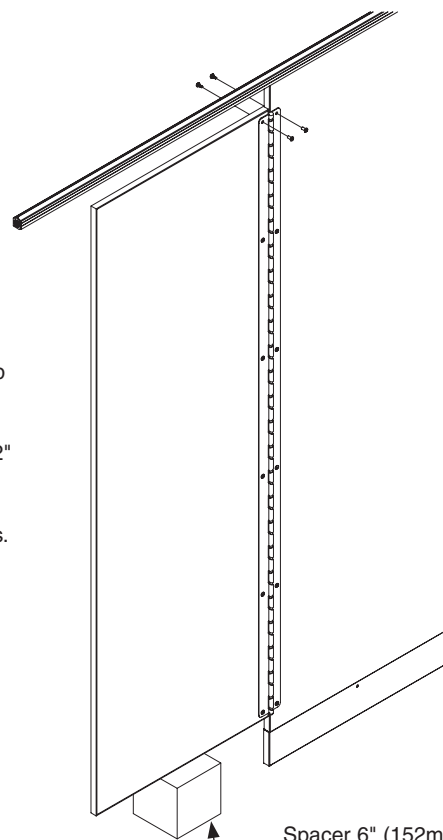

1. Place door on a 6" (152mm) spacer (9" (229mm) spacer for ADA) and set the door gaps. Standard hinge side gap is 3/16" (5mm).
2. Position the hinge so it is plumb and centered within the 3/16" (5mm) gap and centered top to bottom (approximately 1/2" (13mm) down from the top of the door).
3. Using the hinge as a template, drill Ø1/4" holes through the door at the top and bottom holes. Secure the hinge to the door using the #10-24 x 1/2" barrel nuts and #10-24 x 1/2" shoulder screws provided.
4. Verify the hinge side gap is still at 3/16" (5mm). Using the hinge as a template, drill Ø1/4" holes through the pilaster at the top and bottom holes. Secure the hinge to the pilaster using the #10-24 x 1/2" barrel nuts and #10-24 x 1/2" shoulder screws provided.
5. Using the hinge as a template, drill Ø1/4" holes for all remaining hinge holes through both the door and pilaster. Secure hinge with fasteners provided.

Spacer 6" (152mm) for 72" Tall Doors
 ADA Spacer 9" (229mm) for 69" Tall Doors

10 Door Hardware for Inswing Doors - Surface

 Local codes vary from state to state. Check your local codes before installing the coat hook and door pulls.

1. Position latch per dimensions below with the leading edge 1/8" (3mm) from the door edge. Using the latch as a template, mark the hole locations and drill Ø11/64" pilot holes, 5/8" (16mm) deep. Secure latch to door with the #10 x 5/8" screws provided.

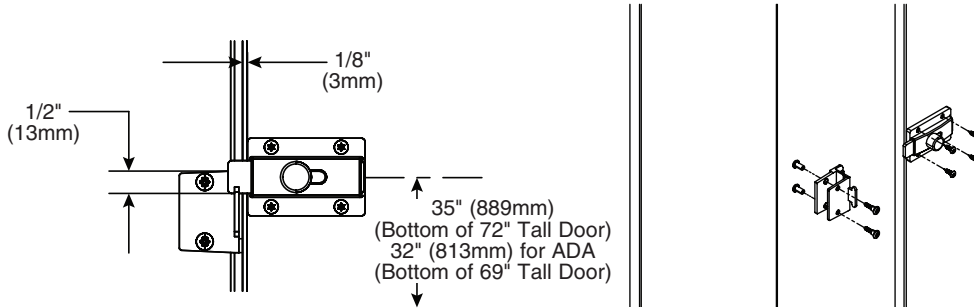

2. With the door in the closed position, position the strike/keeper on the pilaster and align the top so it is 1/2" (13mm) above the bottom of the latch slide bar. Using the strike/keeper as a template, mark the hole locations and drill Ø1/4" holes through the pilaster. Secure the strike/keeper to the pilaster with the #10-24 x 1/2" barrel nuts and #10-24 x 3/4" shoulder screws.

3. For 34" - 36" ADA doors only, mark the location for the top hole on the inside face of the door 33-3/4" (857mm) up from the bottom of 69" tall doors (42-3/4" [1086mm] above finished floor) and 5-1/2" (140mm) from the door edge. Drill (2) Ø1/4" holes (spaced 3-1/2" [89mm] apart) through the door and secure the door pulls to the door as shown with the #10-24 x 2" flat machine screws provided.

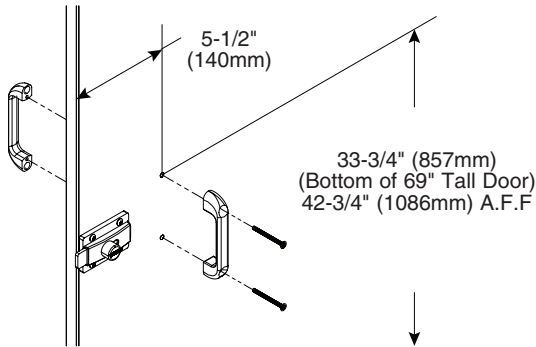

4. Place the coat hook 3" (76mm) down from the top and 3" (76mm) from the latch side of the door (hook goes on the inside face of the door). Using the hook as a template, drill (2) Ø11/64" pilot holes, 5/8" (16mm) deep. secure with the #10 x 5/8" screws provided.

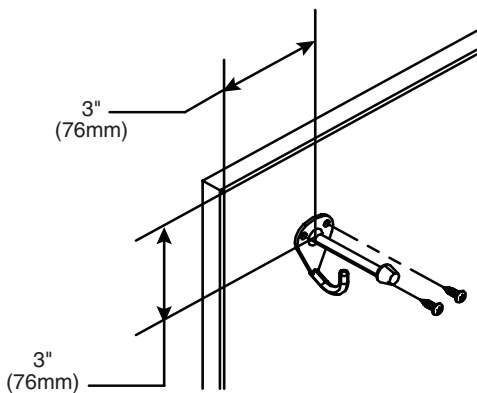

Flat Strike/Keeper

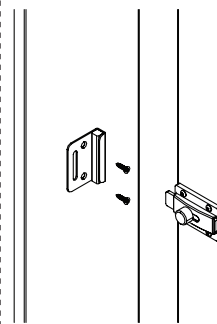

5. With the door in the closed position, place flat strike/keeper so the latch slide bar fits within the slot.

6. Using the flat strike/keeper as a template, drill (2) Ø11/64" pilot holes, 5/8" (16mm) deep. Secure the flat strike/keeper to the pilaster using the #10 x 3/4" flat head screws provided.

10a Door Hardware for Outswing Doors - Surface

 Local codes vary from state to state. Check your local codes before installing the coat hook and door pulls.

1. Position latch per dimensions below with the leading edge 5/8" (16mm) from the door edge. Using the latch as a template, mark the hole locations and drill Ø11/64" pilot holes, 5/8" (16mm) deep. Secure latch and spacer to door with the #10 x 1" screws provided.

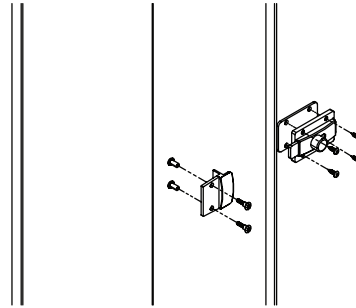
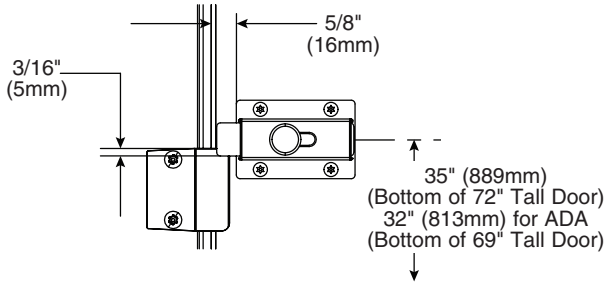

2. With the door in the closed position, position the strike/keeper on the pilaster and align the top so it is a maximum of 3/16" (5mm) above the bottom of the latch slide bar. Using the strike/keeper as a template, mark the hole locations and drill Ø1/4" holes through the pilaster. Secure the strike/keeper to the pilaster with the #10-24 x 1/2" barrel nuts and #10-24 x 3/4" shoulder screws provided.

3. Mark the location for the top hole on the inside face of the door per dimensions below and 5-1/2" (140mm) from the door edge. Drill (2) Ø1/4" holes (spaced 3-1/2" [89mm] apart) through the door and secure the door pulls to the door as shown with the #10-24 x 2" flat machine screws provided.

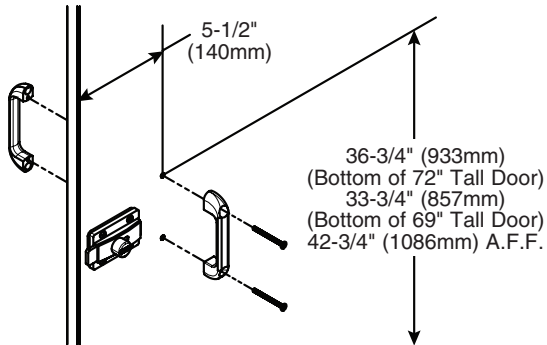

4. Position the wall bumper 3" (76mm) up from the bottom and 3" (76mm) from the latch side of the door (bumper goes on the outside face of the door). Using the bumper as a template, drill (2) Ø11/64" pilot holes, 5/8" (16mm) deep. Secure to door with the #10 x 5/8" screws provided.

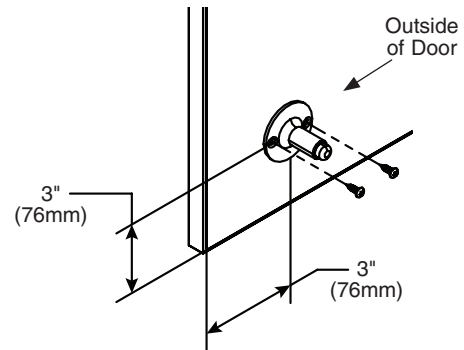

5. Position the coat hook 36" (914mm) above finished floor (hook goes on the inside of compartment). Using the hook as a template, drill (2) Ø15/64" pilot holes, 5/8" (16mm) deep. Secure with the #14 x 5/8" screws provided.

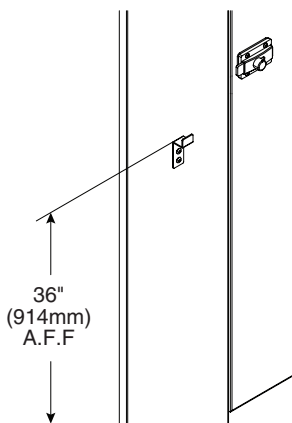

Flat Strike/Keeper

6. With the door in the closed position, position the flat strike/keeper on the pilaster and align the top so it is 3/16" (5mm) above the bottom of the latch slide bar.
7. Using the flat strike/keeper as a template, drill (2) Ø11/64" pilot holes, 5/8" (16mm) deep. Secure the flat strike/keeper to the pilaster using the #10 x 3/4" flat head screws provided.

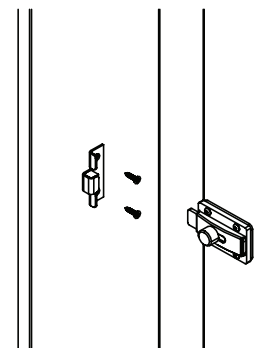

11 Urinal Screens with Continuous Stainless Steel Brackets

- Before installing the urinal screen components, determine the correct location for you application.
- Brackets are used as templates, but since the hole patterns may be different, the brackets may not be interchangeable.

1. Draw a plumb line on the wall to represent the urinal screen centerline. Measure from the highest point in the room and place a mark on the urinal screen centerline at dimension "A" for the respective urinal screen height (see table).
2. Place the bottom of the bracket on the mark and center the opening on the urinal screen centerline. Using the bracket as a template, mark the hole locations on the wall. Remove the bracket and drill a $\text{Ø}5/16"$ hole (minimum 2" [51mm] deep) at each hole location.

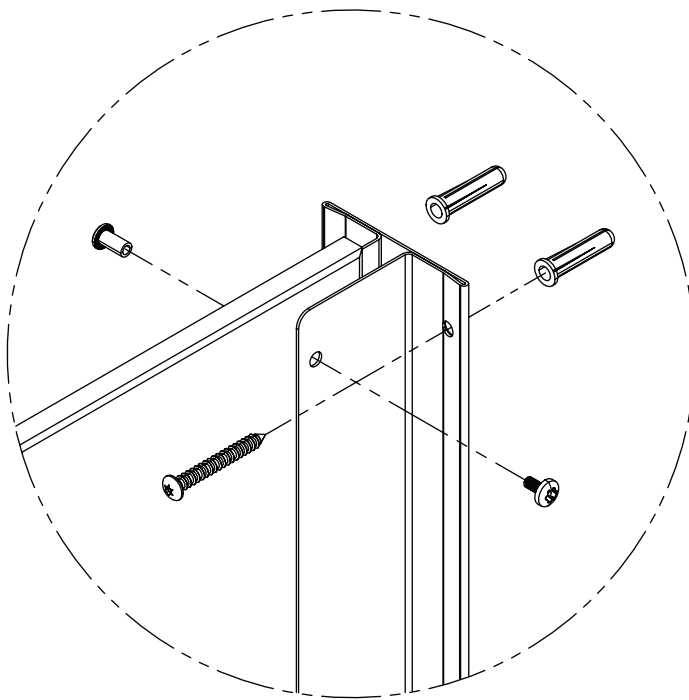

3. Insert plastic anchors in all holes and secure bracket to the wall with the #14 x 2" screws provided.
4. Place the urinal screen at dimension "B" for the respective urinal screen height (see table) and insert it into the wall bracket until a 1" (25mm) gap between the wall and urinal screen is established.
5. Using the bracket as a template, drill $\text{Ø}1/4"$ holes through the urinal screen at each bracket hole. Secure the urinal screen to the bracket with the #10-24 x 1/2" barrel nuts and #10-24 x 3/8" machine screws provided.

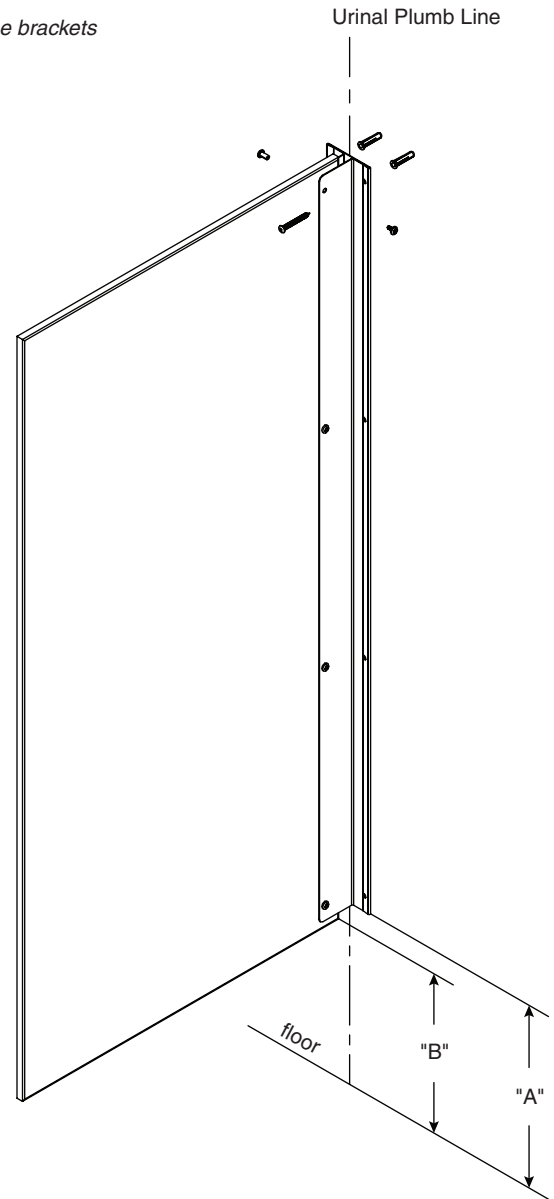

	Dim "A"	Dim "B"
42" Urinal Screen	18-1/2" (470mm)	18" (457mm)
48" Urinal Screen	12-1/2" (318mm)	12" (305mm)