

Cummins **Onan**



Installation Manual

Home Standby Generator Set

C13N6H (Spec A)
C17N6H (Spec A)
C20N6H (Spec A)
C20N6HC (Spec A)

California

Proposition 65 Warning

The engine exhaust from this product contains chemicals known to the State of California to cause cancer, birth defects, or other reproductive harm.

Table of Contents

1. IMPORTANT SAFETY INSTRUCTIONS	1
1.1 Save These Instructions	1
1.2 General Information	1
1.3 General Precautions	1
1.4 Generator Set Voltage Is Deadly	5
1.5 Engine Exhaust Is Deadly	5
1.6 Fuel and Fumes Are Flammable	6
1.7 Batteries Can Explode	6
1.8 Starting Batteries	7
1.9 Moving Parts Can Cause Severe Personal Injury or Death	7
1.10 The Hazards of Carbon Monoxide.....	8
2. INTRODUCTION.....	9
2.1 About This Manual.....	9
2.2 Schedule of Abbreviations	9
2.3 Related Literature	11
2.4 Before Installation	12
2.5 Model Specifications	13
3. PRE-INSTALLATION CONSIDERATIONS.....	17
3.1 Pre-Installation Considerations Introduction.....	17
3.2 Installation Codes and Standards for Safety	18
3.3 Required Items for Installation.....	20
4. INSTALLATION.....	27
4.1 Site Assessment and Preparation	27
4.2 Fuel Selection and Fuel System Connection.....	31
4.3 Engine Exhaust.....	43
4.4 Electrical Connections	44
5. STARTUP AND CONFIGURATION.....	55
5.1 "Establishing Communications" Message	55
5.2 "Clock Setup" Screen.....	55
5.3 "Exercise" Screen	61
5.4 "Brightness and Contrast" Screen	64
5.5 "About" Screen.....	66
5.6 "Event Log" Screen.....	68
5.7 "Fault Log" Screen	69
5.8 "System Status" Screen.....	70
5.9 "Mode" Screen.....	71
5.10 Automatic Load Management.....	74
5.11 Manual Start Sequence (Local)	75
5.12 Checklist	75

5.13 Startup	78
6. OPTIONAL REMOTE MONITORING SYSTEM (RMS) DESCRIPTION	79
6.1 Introduction	79
6.2 Optional Remote Monitoring System (RMS) Account Setup and Generator Set Control Connection	80
APPENDIX A. FUEL LINE SELECTION.....	81
A.0 Fuel System Pipe Sizing Introduction.....	82
A.1 Gas Pipe Sizing.....	83
APPENDIX B. OUTLINE AND SYSTEM DRAWINGS.....	95
APPENDIX C. WIRING DIAGRAMS.....	101
C.0 Wiring Diagrams.....	102

1 Important Safety Instructions

1.1 Save These Instructions

This manual contains important instructions for the generator set that should be followed during installation, operation and maintenance of the generator set and batteries.

Thoroughly read the operator manual before operating the generator set. Safe operation and top performance can only be obtained when equipment is properly operated and maintained.

The following symbols in this manual alert you to potential hazards to the operator, service person and equipment.

DANGER

Alerts you to an immediate hazard that will result in severe personal injury or death.

WARNING

Alerts you to a hazard or unsafe practice that can result in severe personal injury or death.

CAUTION

Alerts you to a hazard or unsafe practice that can result in personal injury or equipment damage.

1.2 General Information

This manual should form part of the documentation package supplied by Cummins Power Generation with specific generator sets. In the event that this manual has been supplied in isolation please contact your authorized dealer.

NOTICE

It is in the operator's interest to read and understand all warnings and cautions contained in the documentation relevant to the generator set operation and daily maintenance.

1.3 General Precautions

- Keep ABC fire extinguishers accessible.
- Make sure that all fasteners are secure and torqued properly.

- Keep the generator set and its compartment clean. Do not store any items in the generator set compartment.
- Before working on the generator set, make sure the generator set is shut down and disabled.
 1. Press the generator set's "O" (Off) button or the red STOP button on the local display (whichever is applicable) to stop the generator set. Allow the generator set to thoroughly cool to the touch.
 2. If applicable, turn off and disconnect the battery charger from the AC source before disconnecting the battery cables.
 3. Disconnect the negative (-) cable from the battery and secure it from contacting the battery terminals to prevent accidental starting.
- Use caution when making adjustments when the generator set is running, hot, or when parts are electrically live, as all situations may cause personal injury or death.
- Used engine oil has been identified by some state and federal agencies as causing cancer or reproductive toxicity. Do not ingest, inhale, or come into contact with used oil or its vapors.
- Do not work on the generator set when mentally or physically fatigued or after consuming alcohol or drugs.

NOTICE

Only trained and authorized personnel shall maintain or service the generator set.

NOTICE

The installation of the generator set shall provide enough ventilation to ensure that gases generated by vented batteries during charging, or caused by equipment malfunction, are removed.

General Safety Precautions

⚠ WARNING***Hazardous Voltage***

Contact with high voltages can cause severe electrical shock, burns, or death.

Make sure that only a trained and experienced electrician makes generator set electrical output connections, in accordance with the installation instructions and all applicable codes.

⚠ WARNING**Electrical Generating Equipment**

Faulty electrical generating equipment can cause severe personal injury or death.

Generator sets must be installed, certified, and operated by trained and experienced person in accordance with the installation instructions and all applicable codes.

⚠ WARNING**Moving Parts**

Moving parts can cause severe personal injury.

Use extreme caution around moving parts. All guards must be properly fastened to prevent unintended contact.

⚠ WARNING**Toxic Hazard**

Used engine oils have been identified by some state and federal agencies to cause cancer or reproductive toxicity.

Do not ingest, breathe the fumes, or contact used oil when checking or changing engine oil. Wear protective gloves and face guard.

⚠ WARNING**Electrical Generating Equipment**

Incorrect operation and maintenance can result in severe personal injury or death.

Do not operate equipment when fatigued, or after consuming any alcohol or drug.

Make sure that only suitably trained and experienced service personnel perform electrical and/or mechanical service.

⚠ WARNING**Toxic Gases**

Substances in exhaust gases have been identified by some state and federal agencies to cause cancer or reproductive toxicity.

Do not breathe in or come into contact with exhaust gases.

⚠ WARNING**High Noise Level**

Generator sets in operation emit noise, which can cause hearing damage.

Wear appropriate ear protection at all times.

⚠ WARNING**Hot Surfaces**

Contact with hot surfaces can cause severe burns.

Wear appropriate PPE when working on hot equipment and avoid contact with hot surfaces.

⚠ WARNING**Combustible Liquid**

Ignition of combustible liquids is a fire or explosion hazard which can cause severe burns or death.

Do not store fuel, cleaners, oil, etc., near the generator set. Do not use combustible liquids like ether.

⚠ WARNING**Combustible Gases**

Generator sets in operation have combustible gases under pressure, which if ignited can cause eye and ear damage.

- **Wear appropriate eye and ear protection at all times.**
- **Do not operate the generator set with any doors open.**

⚠ WARNING**Fire Hazard**

Materials drawn into the generator set, as well as accumulated grease and oil, are a fire hazard. Fire can cause severe burns or death.

Keep the generator set and the surrounding area clean and free from obstructions. Make sure the generator set is mounted in a manner to prevent combustible materials from accumulating under the unit.

⚠ WARNING**Automated Machinery**

Accidental or remote starting of the generator set can cause severe personal injury or death.

The generator set must be off and locked out of service whenever the air inlet, air outlet, or any interior panels are removed.

⚠ WARNING**Automated Machinery**

Accidental or remote starting of the generator set can cause severe personal injury or death.

Isolate all auxiliary supplies and use an insulated wrench to disconnect the starting battery cables (negative [-] first).

NOTICE

Keep multi-class ABC fire extinguishers handy. Class A fires involve ordinary combustible materials such as wood and cloth. Class B fires involve combustible and flammable liquid fuels and gaseous fuels. Class C fires involve live electrical equipment. (Refer to NFPA No. 10 in applicable region.)

NOTICE

Before performing maintenance and service procedures on enclosed generator sets, make sure the service access doors are secured open.

NOTICE

Stepping on the generator set can cause parts to bend or break, leading to electrical shorts, or to fuel, coolant, or exhaust leaks. Do not step on the generator set.

1.4 Generator Set Voltage Is Deadly

- Generator set output connections must be made by a trained and experienced electrician in accordance with all applicable codes.
- This generator set and the public utility may only be connected to house circuits by means of the automatic transfer switch.

⚠ CAUTION

Improper connections can lead to electrocution of utility workers and damage to equipment. Make sure that the connections are installed properly by a trained technician.

- Use caution when working on live electrical equipment. Remove jewelry, and make sure clothing and shoes are dry. Stand on a dry wooden platform.

1.5 Engine Exhaust Is Deadly

- See [The Hazards of Carbon Monoxide](#) to learn the symptoms of Carbon Monoxide poisoning.
- Locate the generator set away from doors, windows, other openings into the house, and where exhaust gases will disperse away from the house.

1.6 Fuel and Fumes Are Flammable

Fire, explosion, and personal injury or death can result from improper practices.

- DO NOT permit any flame, cigarette, pilot light, spark, arcing equipment, or other ignition source near the generator set or fuel system.
- Fuel lines must be adequately secured and free of leaks. Fuel connection at the engine should be made with an approved flexible line. Do not use copper piping on flexible lines because copper will become brittle if continuously vibrated or repeatedly bent.
- Be sure all fuel supplies have a positive shutoff valve.
- Be sure the battery area has been well-ventilated prior to servicing near it. Lead-acid batteries emit a highly explosive hydrogen gas that can be ignited by arcing, sparking, smoking, etc.

1.7 Batteries Can Explode

Batteries can explode, causing severe skin and eye burns and can release toxic electrolytes.

WARNING

Combustible Gases

Batteries can explode, causing severe skin and eye burns, and can release toxic electrolytes.

Do not dispose of the battery in a fire, because it is capable of exploding. Do not open or mutilate the battery.

WARNING

Electric Shock Hazard

Batteries present the risk of high short circuit current.

Remove watches, rings, or other metal objects. Use tools with insulated handles.

NOTICE

Servicing of batteries must be performed or supervised by personnel knowledgeable of batteries and the required precautions. Keep unauthorized personnel away from batteries.

- Wear safety glasses.
- Do not smoke.
- To prevent arcing when disconnecting the battery:
 1. Press the Off switch from the display and then press the E-Stop button.
 2. Disconnect AC power from any battery chargers.

3. Remove the negative (-) battery cable to prevent starting.
- To prevent arcing when reconnecting the battery:
 1. Reconnect the positive (+) cable.
 2. Reconnect the negative (-) cable.
 3. Reconnect the battery charger to AC power supply.
 - When replacing the generator set battery, always replace it with a battery as specified in this manual.

1.8 Starting Batteries

WARNING

Toxic Hazard

The electrolyte in starting batteries is a dilute sulfuric acid that is harmful to the skin and eyes. It is also electrically conductive and corrosive.

Always:

- 1. Wear full eye protection and protective clothing;***
- 2. If the electrolyte contacts the skin, wash it off immediately with water;***
- 3. If the electrolyte contacts the eyes, flush them thoroughly and immediately with water and seek medical attention; and***
- 4. Wash spilled electrolyte down with an acid neutralizing agent. A common practice is to use a solution of one pound (500 grams) bicarbonate of soda (also known as baking soda or sodium bicarbonate) to one gallon (4 liters) of water.***
- 5. Continue to add the bicarbonate of soda solution until the evidence of reaction (that is, foaming) has stopped.***
- 6. Flush the resulting liquid with water and dry the area.***

1.9 Moving Parts Can Cause Severe Personal Injury or Death

- Do not wear loose clothing or jewelry near moving parts, such as fans.
- Keep hands away from moving parts.
- Keep guards in place over fans.

1.10 The Hazards of Carbon Monoxide

Carbon monoxide (CO) is an odorless, colorless, tasteless and non-irritating gas. You cannot see it or smell it. Red blood cells, however, have a greater affinity for CO than for oxygen. Therefore, exposure even to low levels of CO for a prolonged period can lead to asphyxiation (lack of oxygen) resulting in death. Mild effects of CO poisoning include eye irritation, dizziness, headaches, fatigue and the inability to think clearly. More extreme symptoms include vomiting, seizures and collapse.

Engine-driven generator sets produce harmful levels of carbon monoxide that can injure or kill you.

Special Risks of CO near the Home

 **WARNING**

Toxic Gases

Carbon monoxide (CO) gas can cause nausea, fainting, or death. Residents can be exposed to lethal levels of CO when the generator set is running. Depending on air temperature and wind, CO can accumulate in or near the home.

To protect yourself and others from the dangers of CO poisoning, it is recommended that reliable, approved, and operable CO detector alarms are installed in proper locations in the home as specified by their manufacturer.

Protecting Yourself from CO Poisoning

- Locate the generator set in an area where there are no windows, doors, or other access points into the home.
- Make sure all CO detectors are installed and working properly.
- Pay attention for signs of CO poisoning.
- Check the exhaust system for corrosion, obstruction, and leaks every time you start the generator set and every eight hours when you run it continuously.

2 Introduction

2.1 About This Manual

⚠ WARNING

Improper installation can result in severe personal injury, death and damage to equipment. The installation must comply with all applicable building codes (including project permits and inspections). The installer should be properly trained and licensed to perform electrical and mechanical equipment installations (including gaseous fuel installation).

NOTICE

Manuals are updated from time to time to reflect changes in the equipment and its specifications. The most up-to-date version of this manual is found on the QuickServe website (<https://quickserve.cummins.com/info/index.html>).

This manual is a guide for the installation of the generator set models listed on the front cover. Proper installation is essential for top performance, reliable operation, and safety. Read through this manual before starting the installation. This manual covers outdoor applications only; this product must **never** be installed indoors.

NOTICE

The installation must comply with all applicable building codes.

See the generator set's specific Operator Manual for operation and maintenance and specific Service Manual for service.

Refer to the Model Specifications section for specific information about the system and its components.

Refer to the Outline and System Drawings appendix and the Wiring Diagrams appendix for specific information about installation and wiring connections.

2.2 Schedule of Abbreviations

This list is not exhaustive. For example, it does not identify units of measure or acronyms that appear only in parameters, event/fault names, or part/accessory names.

Abbr.	Description	Abbr.	Description
AC	Alternating Current	LED	Light-Emitting Diode
AMP	AMP, Inc. (part of Tyco Electronics)	MFM	Multifunction Monitor

Abbr.	Description	Abbr.	Description
ANSI	American National Standards Institute	Mil Std	Military Standard
ASOV	Automatic Shut Off Valve	MPU	Magnetic Pickup
ASTM	American Society for Testing and Materials (ASTM International)	NC	Normally Closed
ATS	Automatic Transfer Switch	NC	Not Connected
AVR	Automatic Voltage Regulator	NFPA	National Fire Protection Agency
AWG	American Wire Gauge	NO	Normally Open
CAN	Controlled Area Network	NWF	Network Failure
CB	Circuit Breaker	OEM	Original Equipment Manufacturer
CE	Conformité Européenne	OOR	Out Of Range
CCA	Cold Cranking Ampere	OORH/ ORH	Out Of Range High
CFM	Cubic Feet per Minute	OORL/ORL	Out Of Range Low
CGT	Cummins Generator Technologies	PB	Push Button
CMM	Cubic Meters per Minute	PCC	PowerCommand® Control
CT	Current Transformer	PGI	Power Generation Interface
DC	Direct Current	PGN	Parameter Group Number
DEF	Diesel Exhaust Fluid	PI	Proportional/Integral
DPF	Diesel Particulate Filter	PID	Proportional/Integral/ Derivative
EBS	Excitation Boost System	PLC	Programmable Logic Controller
ECM	Engine Control Module	PMG	Permanent Magnet Generator
ECS	Engine Control System	PPE	Personal Protective Equipment
EMI	Electromagnetic Interference	PT	Potential Transformer

Abbr.	Description	Abbr.	Description
EN	European Standard	PTC	Power Transfer Control
EPS	Engine Protection System	PWM	Pulse-Width Modulation
E-Stop	Emergency Stop	RFI	Radio Frequency Interference
FAE	Full Authority Electronic	RH	Relative Humidity
FMI	Failure Mode Identifier	RMS	Remote Monitoring System
FSO	Fuel Shutoff	RMS	Root Mean Square
Genset	Generator Set	RTU	Remote Terminal Unit
GCP	Generator Control Panel	SAE	Society of Automotive Engineers
GND	Ground	scfh	Standard Cubic Feet of gas per Hour
HMI	Human-Machine Interface	SCR	Selective Catalytic Reduction
IC	Integrated Circuit	SPN	Suspect Parameter Number
ISO	International Organization for Standardization	SW_B+	Switched B+
LBNG	Lean-Burn Natural Gas	UL	Underwriters Laboratories
LCD	Liquid Crystal Display	UPS	Uninterruptible Power Supply
LCT	Low Coolant Temperature		

2.3 Related Literature

Before any attempt is made to operate the generator set, the operator should take time to read all of the manuals supplied with the generator set and familiarize themselves with the warnings and operating procedures.

NOTICE

A generator set must be operated and maintained properly if you are to expect safe and reliable operation. The Operator manual includes a maintenance schedule and a troubleshooting guide.

The Health and Safety manual must be read in conjunction with this manual for the safe operation of the generator set, as well as the Warranty Statements.

The literature provided with the generator set is as follows:

- Installation Manual (A053X172)
- Operator Manual (A053X174)
- Quick Start Installation Guide (A053X181)
- Quick Start Operator Guide (A053X183)
- Health and Safety Manual (0908-0110-00)
- Global Warranty Statement (A056F206)
- Emission Warranty Statement (Federal Emissions EPA Title 40 CFR Part 90 Component Warranty) (A028X278)

The relevant manuals appropriate to your generator set are also available. The documents below are in English:

- Generator Set Service Manual (A053X177)
- RA Series RA112L1 Automatic Transfer Switch Owner Manual (A052S254) - if applicable
- RA Series 100A/200A/400A Automatic Transfer Switch Owner Manual (A046S594) - if applicable
- Parts Manual (A053X179)
- Standard Repair Times - HO Family (A053X186)
- Service Tool Manual (A043D529)
- Warranty Failure Code Manual (F1115C)
- Engineering Application Manual T-030: Liquid Cooled Generator Sets (A040S369)

2.4 Before Installation

Before beginning the installation of the generator set, verify that the unit was correctly selected. Check the following features:

- Model
- Specifications
- Options

- Fuel Supply
 - The gas supplied to the generator set must be of acceptable quality.
 - The gas supply must have sufficient pressure. Care must be taken to be sure that the gas supply at the generator set, not just at the source, is of proper pressure for operation. The specified pressure must be available while the generator set is starting and running at full load.
 - The gas must be supplied to the generator set in sufficient volume to support operation of the generator set. This is normally a matter of selecting fuel line size to be large enough to transport the volume of fuel needed. For liquid propane vapor-withdrawal fuel systems the size and temperature of the fuel tank also affects this requirement.

2.5 Model Specifications

TABLE 1. MODEL VARIATIONS

Model	Natural Gas or Propane Vapor	kW	Amps	Frequency	Voltage
C13N6H	Both	13	54.2	60 Hz	120/240 VAC Single Phase
C17N6H	Both	17	70.8		
C20N6H, C20N6HC	Natural Gas Only	18	75		
	Propane Vapor Only	20	83.3		

NOTICE

Maximum load imbalance allowed is 50% of generator set rating.

TABLE 2. COLD WEATHER SPECIFICATIONS (ALL MODELS)

Temperature	Description
Above 40 °F (4 °C)	No starting aids required
0 to 40 °F (-17 to 4 °C)	Alternator heater (supplied with the generator set)
Below 0 °F (-17 °C)	<ul style="list-style-type: none"> • Alternator, battery, oil and regulator heaters • 0W30 oil (see Lubricating Oil System Specifications) • Accessory kit available

TABLE 3. FUEL SPECIFICATIONS (AT FULL LOAD) (ALL MODELS)

Type	C13N6H		C17N6H		C20N6H, C20N6HC	
	scfh	BTU/hr	scfh	BTU/hr	scfh	BTU/hr
Natural Gas	253	260,000	289	297,000	300	309,000
Propane	85	212,000	101	252,000	116	290,000
Fuel Pressure	Natural Gas: 3.5 - 12 inch water column (0.9 - 3.0 kPa) Propane Vapor: 6 - 12 inch water column (1.5 - 3.0 kPa) Maximum pressure for either fuel under any condition: 13 inch water column (3.2 kPa)					

TABLE 4. ENGINE SPECIFICATIONS (ALL MODELS)

Type	Value
Engine	2 cylinder v-twin, OHV, air-cooled, 4-stroke, spark ignited
Displacement	999 cc (60.9 in ³)
Spark Plug Gap	0.7 - 0.8 mm (0.027 - 0.031 in)
Spark Plug Torque (Cold Engine)	25 - 30 Nm (18 - 22 ft-lb)
RPM	3600
Lubricating Oil Pressure at Rated Speed (Minimum)	45 psi (310 kPa)
Oil Recommendation	Full synthetic gasoline engine oil which meets or exceeds API service SN/SN-RC and ILSAC GF-5: <ul style="list-style-type: none"> • 5W30: Temperatures above 0 °F (-18 °C) • 0W30: All temperatures, required below 0 °F (-18 °C)
Lubricating Oil Capacity:	
Lubricating Oil Pressure at Rated Speed (Minimum)	310 kPa (45 psi)
--Full at High Mark on Dipstick	2.3 L (2.4 qt)
--Low Mark on Dipstick	1.3 L (1.4 qt)

TABLE 5. GENERATOR SET SIZE (ALL MODELS)

Dimension	Value
Length	877 mm (34.5 in)
Width	915 mm (36 in)
Height	694 mm (27.3 in)

TABLE 6. GENERATOR SET WET WEIGHT (INCLUDING BATTERY)

Model	Value
C13N6H	218 kg (479 lb)
C17N6H, C20N6H, C20N6HC	241 kg (531 lb)

TABLE 7. GENERATOR SET DERATING GUIDELINES

Model	Engine Power Available Up To...		Derate At...	
	Elevation	Ambient Temperature	Elevation	Temperature
C13N6H	2100 m (6900 ft)	25 °C (77 °F)	3.5% per 300 m (1000 ft)	1% per 5.5 °C (10 °F)
C17N6H	300 m (1000 ft)	25 °C (77 °F)		
C20N6H, C20N6HC	0 m (0 ft)	15 °C (60 °F)		

NOTICE

Derating guidelines: This product's output power is limited by factors such as BTU content of fuel, ambient temperature, altitude, humidity, engine condition, etc. The derating guidelines are based on properly maintained product, using the appropriate fuel. Derate values are based on expected engine power changes from elevation and temperatures listed.

TABLE 8. ALTERNATOR SPECIFICATIONS (ALL MODELS)

Type	Specification
Design	Rotating field
Poles	2
RPM	3600
Voltage	240
Hz	60

TABLE 9. CONTROL SPECIFICATIONS (ALL MODELS)

Control
Integrated Microprocessor-Based Engine, Alternator, Transfer Switch Controller

TABLE 10. DC SYSTEM SPECIFICATIONS (ALL MODELS)

Type	Value
Nominal Battery Voltage	12 VDC
Battery Group	51 R
Battery Type	Lead Acid
Minimum Cold Crank Amps (CCA)	450

3 Pre-Installation Considerations

3.1 Pre-Installation Considerations Introduction

⚠ WARNING

The installer is responsible for complying with all applicable installation codes and safety requirements. See the Installation Codes and Standards for Safety section of this manual for more information.

The following sections create a step-by-step overview of a typical generator set installation. Review these sections to become familiar with specific procedures and important safety before beginning the installation.

NOTICE

For information on tools and materials, see the Required Items for Installation section. For information on locating the generator set, see the Installation section. For codes and standards, see the Installation Codes and Standards for Safety section. For specifications, see the Model Specification section.

Areas of consideration:

- Location of the generator set: this is one of the first decisions to be made, as it affects all other aspects of the installation, such as:
 - Length of electric wiring
 - Length of gas lines (natural gas or propane - must be inspected by the gas utility inspectors and building inspectors)
 - Site preparation:
 - Access to the site
 - Trenches
 - Site preparation materials needed
- Fuel supply pressure
- Automatic transfer switch location and connections
- Tools and materials required
- Minimum distance from the propane tank fill:
 - Verify the legal minimum distance with local code officials.
 - Verify the minimum distance from the service pressure regulator to the generator set.

- Verify any minimum clearance requirements to the generator set that the gas supplier or equipment supplier may have.
- Accessories required (if any) for the customer's application (utility power is required at the generator set for the battery charger and may be required for the heaters; make plans accordingly)

NOTICE

Depending on the locality and use of the generator set, it may be necessary to obtain an air quality emissions permit before installation begins. Check with local pollution control or air quality authority to determine permit requirements.

3.2 Installation Codes and Standards for Safety

NOTICE

The generator set installer bears sole responsibility for following all applicable local codes and regulations.

The following list of codes and standards may apply to the installation and operation of the generator set. This list is for reference only and not intended to be inclusive of all applicable codes and standards. The address of each agency is listed so that copies of the codes may be obtained for reference. Installation codes and recommendations are subject to change, and may vary by location or over time.

TABLE 11. INSTALLATION CODES AND STANDARDS FOR SAFETY RECOMMENDATIONS

Code or Standard	Organization
NFPA 37 - Installation and Use of Stationary Combustion Engines and Gas Turbines NFPA 54 - National Fuel Gas Code NFPA 58 - Storage and Handling of Liquefied Petroleum Gases NFPA 70 - National Electrical Code	National Fire Protection Association 470 Atlantic Avenue Boston, MA 02210
CSA Electrical Bulletin CSA 22.1 Canadian Electrical Code CSA B149 CSA C22.2 No. 100 CSA C22.2 No. 14	Canadian Standards Association Housing and Construction Materials Section 178 Rexdale Blvd. Rexdale, Ontario, Canada M9Q 1R3

Code or Standard	Organization
California Administrative Code - Title 25 Chapter 3	State of California Documents Section P.O. Box 1015 North Highlands, CA 95660

Operating the Generator Set Cover Safely

To configure the local display or access the generator set, you will need to lift the cover (lid). The cover of the generator set is designed to latch securely into the "up" position to prevent accidental closure.

- *To open:* Lift the cover until the hinge pin drops into the hinge pin slot. Test that the cover is secure by gently pressing down on the cover.
- *To close:* Lift up on the cover while pressing upward on the hinge pin and slide the pin upwards out of the hinge pin slot. Carefully push the cover downward and let go of the hinge pin allowing it to ride along the hinge until the cover is closed.

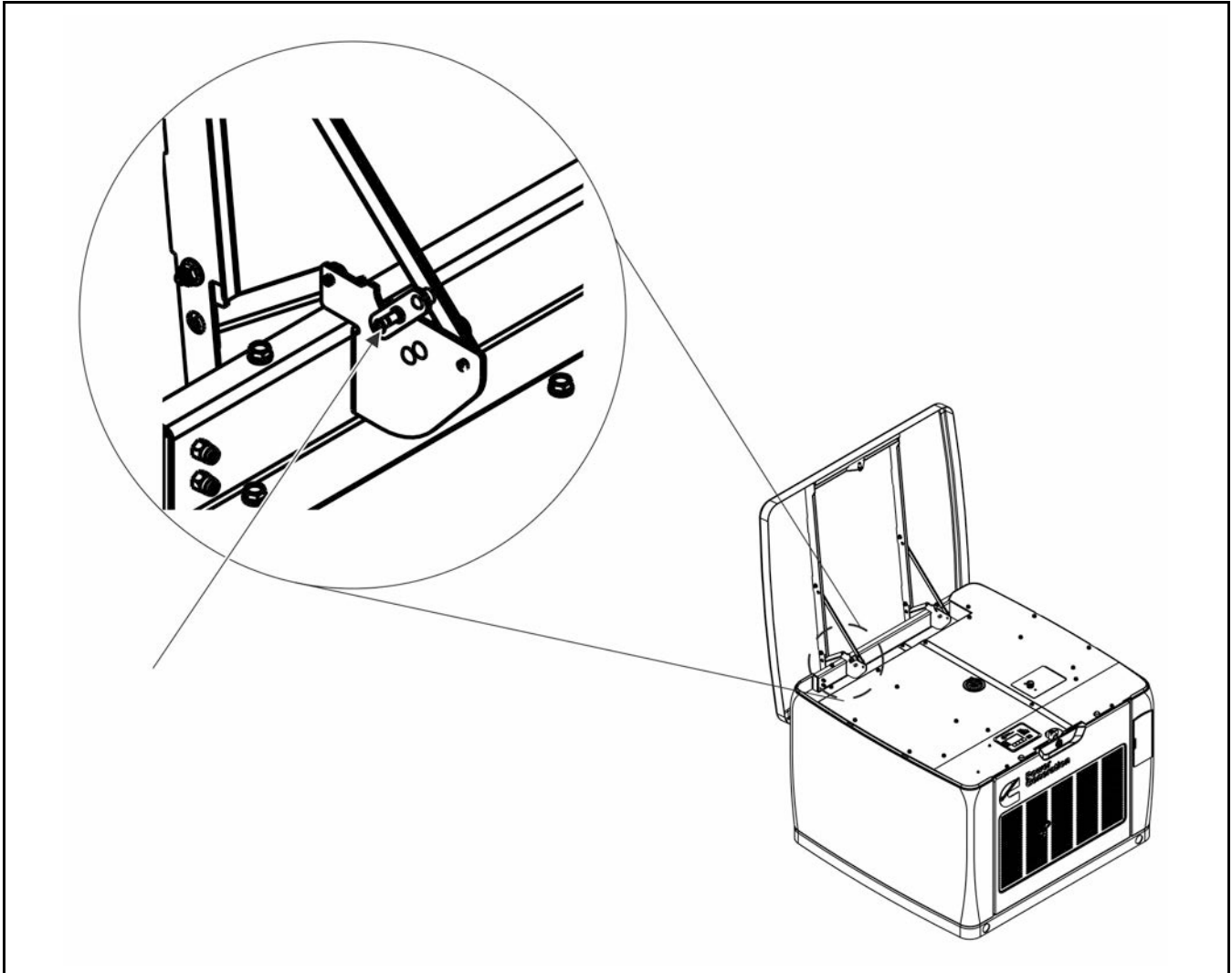
**FIGURE 1. HINGE LOCATION**

3.3 Required Items for Installation

Tools and materials are used for the installation of this generator set. These items are identified in the following sections. Please refer to local codes and standards, because they may affect the materials required.

Materials Required

NOTICE

Refer to local codes and standards, which may affect material requirements.

NOTICE

A UL-listed grounding electrode terminal within its ratings and suitable for the application must be installed and labeled “Grounding Electrode Terminal”.

NOTICE

Class 1 wiring methods must be used for connecting the generator set.

TABLE 12. MATERIALS REQUIRED

Requirement	Specification
Electrical Materials	
Code compliant AC power wires	Four (L1, L2, N and Gnd)
For accessories (alternator heater, oil heater, battery heater, and/or regulator heater) (if equipped)	Code compliant 20 A, 120 VAC, GFCI protected circuit, copper wire only
RA switches only: Control wires from the generator set to the transfer switch	Four DC wires
Ethernet cable for Internet installation (as required)	Cat 5, Cat 5e or Cat 6
All AC and DC wire and cable ratings	Must be 75 °C minimum with 600 V minimum insulation, stranded copper, rated for wet locations. ¹
Wire sizes (for all DC customer connections): Under 1000 ft wire length	18-14 AWG
Conduit	Code compliant for all wires
Mounting Materials	
Bolts or anchor assemblies	Two base tie-down
Fuel System Materials	
Fuel line	Flexible
Pipe thread sealant	UL listed
Fuel service pressure regulator (as required)	--
Manual fuel shut-off at generator set ahead of automatic valves on generator set fuel system	--
Remote Display Materials (if Applicable)	
Remote display	--

Requirement		Specification
Hardware, Cummins provided:	Pigtail harnesses	Two (one for local display and one for remote display); 5-wire (RS485-A ² , RS485-B ² , B+, WAKEUP and B-), 1 ft long each
Hardware, customer provided:	Intermediate wires of required length to connect to the pigtail harnesses using splices provided in the remote display kit	Five wires, 600V insulation ^{1, 2}
Wire sizes (RS485-A ² , RS485-B ² , B+, WAKEUP):	Under 1000 ft wire length	20-14 AWG
Wire sizes (B+ and B-):	Under 100 ft wire length	18 AWG
	Under 200 ft wire length	16 AWG
	Under 300 ft wire length	14 AWG
Hardware, Miscellaneous	If wires can be concealed in a wall cavity:	3 wall anchors and screws (number 6 or number 8)
	If wires cannot be concealed in a wall cavity:	3 wall anchors and screws (number 6 or number 8), standoffs, and conduit or wire raceway
¹ 300V insulation is acceptable for Ethernet and DC cables if routed in a separate conduit from AC wiring. ² Use twisted pair wires for RS485-A and RS485-B wires.		

Tools Required

Use appropriate lifting techniques to position the generator set in place.

Transfer Switch Requirements

A transfer switch must be a part of every generator set installation. Transfer switches transfer loads to the generator set during power outages.

NOTICE

Cummins offers a variety of transfer switches, including residential and light commercial options.

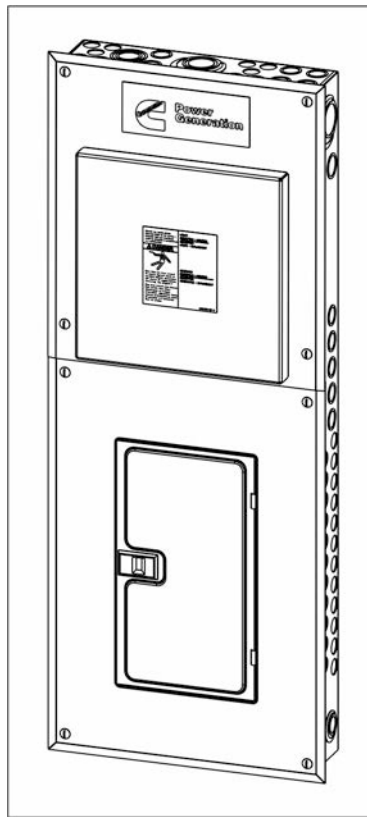

FIGURE 2. CUMMINS AUTOMATIC TRANSFER SWITCH (ATS)

Before beginning the installation of the transfer switch, verify that the unit was correctly selected. Check the following features:

- Specifications (voltage, amperage, frequency, poles, and phases)
- Enclosure (indoor vs. outdoor)
- Model

Cummins recommends that any RA series transfer switch be used with these generator sets. Refer to the appropriate RA series ATS owner manual for more detailed information.

Choosing a Transfer Switch

This section includes block diagrams showing partial or full load coverage for the following Cummins UL 1008 listed transfer switches:

TABLE 13. CUMMINS TRANSFER SWITCH MODELS

Model	Non-Service Entrance	Service Entrance
RA 100A	■	■
RA 200A	■	■
RA 400A	■	■
RA112L1	■	

NOTICE

These generator sets can be used with either service entrance transfer switches or non-service entrance transfer switches.

NOTICE

If the load exceeds the generator set rating, it may be necessary to use Cummins' load management kit (A051C329).

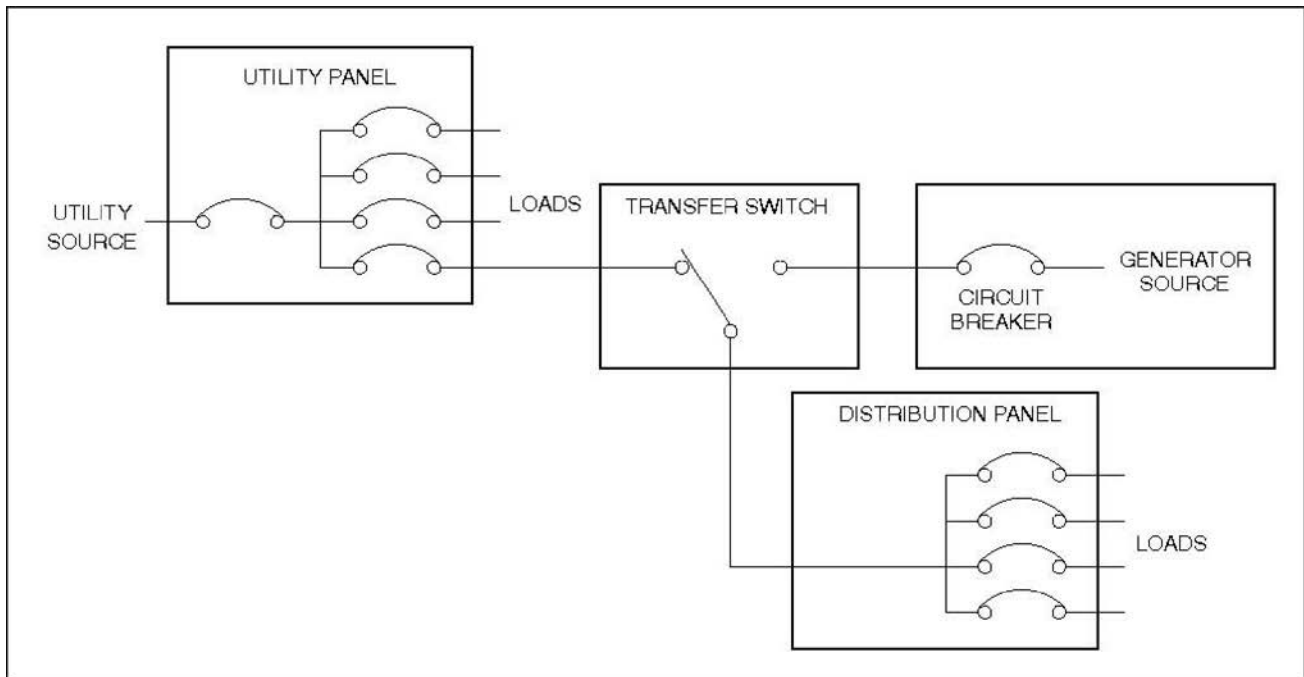

FIGURE 3. TRANSFER SWITCH CONNECTIONS FOR PARTIAL COVERAGE LOAD

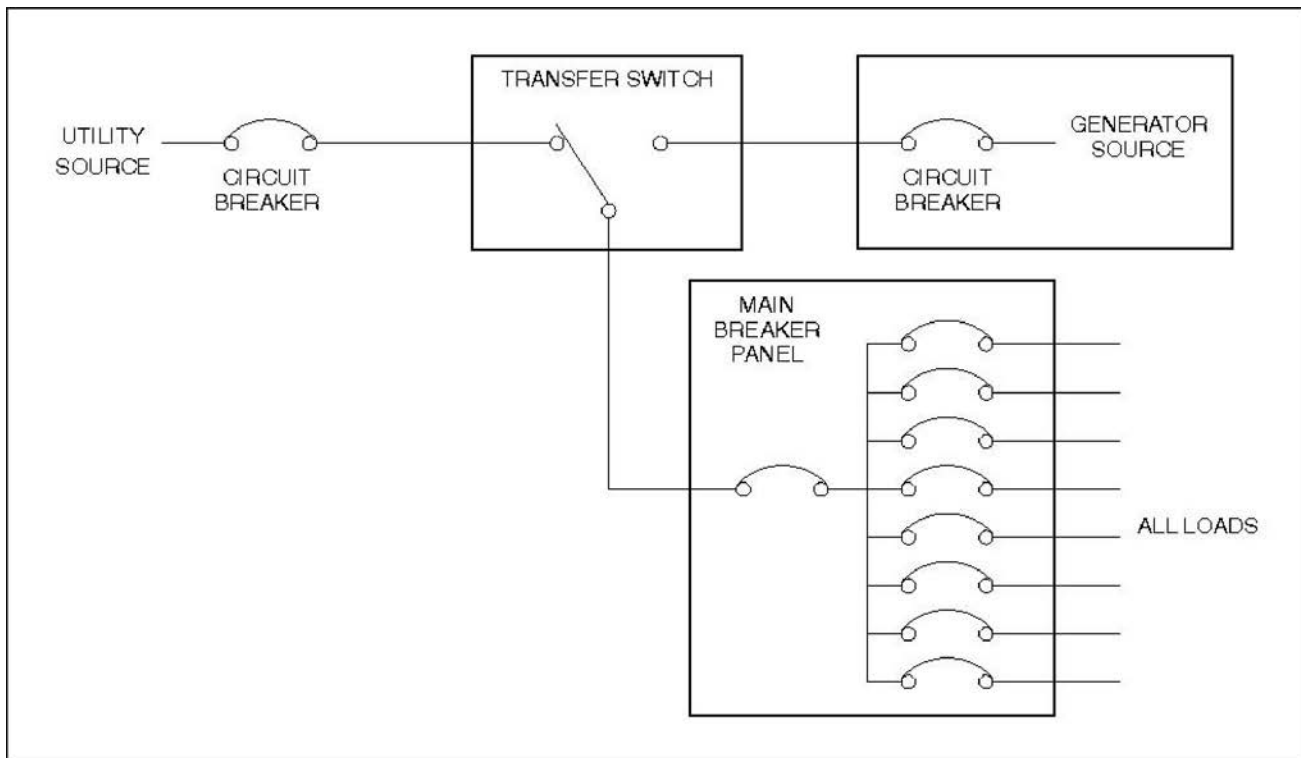

FIGURE 4. TRANSFER SWITCH CONNECTIONS FOR FULL COVERAGE LOAD

Loose Parts Shipped with the Generator Set

The following loose parts are shipped with the generator set:

- Two enclosure keys
- Generator set mounting spacers
- Circuit breaker cover and screw
- Chassis plugs
- Transfer switch TB4 jumper

NOTICE

This jumper must be installed in the RA series transfer switch according to the interconnect diagram in the RA series transfer switch owner manual.

- Literature (Operator Manual, Quick Start Operator Guide, Installation Manual, Quick Start Installation Guide, Health and Safety Manual, and Warranty Statements)

This page is intentionally blank.

4 Installation

4.1 Site Assessment and Preparation

Proper component location and site preparation have a very important impact on completing a successful installation. The major components and sources of power needed for installation include the following items:

- Generator set
- Transfer switch
- Electrical utility
- Fuel source
- Accessories (may be required under certain conditions)

Generator Set Installation Suggestions and Guidelines

- Locate the generator set on stable ground, not subject to flooding. Generator set should not be installed where significant water runoff from a roof or downspouts is present. Sump pump discharge should be routed away from the generator set.
- Locate and orient the generator set such that prevailing winds will carry exhaust gases and fuel leaks away from the house or occupied areas.
- This unit is to be installed so that the risk of contact by people is minimized.

Picking a Location

⚠ WARNING

Exhaust gas is deadly. Install the generator set outdoors only. Locate the generator set away from doors, windows, and other openings to the house and where exhaust gases will disperse away from the house or occupied areas.

NOTICE

All parts of the generator set enclosure must be at least 60 inches (1524 mm) from any openings in walls of structures that may be occupied.

Generator set location is critical for safety and performance. Follow the guidelines below:

- The installation must comply with all applicable codes and standards (NFPA, NEC, IBC, etc.).
- This manual only covers outdoor installations with Cummins factory installed enclosures. This product must **never** be installed indoors.

-
- Consider access to utilities (electric meters, transfer switch, fuel supply line and fuel tank, etc.).
 - Call the local utilities to mark the locations of buried utility services (gas, electric, telephone, etc.) before digging.
 - Verify the locations of any other buried components (gas, electric telephone, etc.) with the homeowner before digging.
 - Consideration should be given to the location of sprinkler heads for irrigation systems. The generator set should not be located where it is subjected to substantial wetting (especially on the inlet air side) when the irrigation system is in operation.
 - Always install this generator set service regulator above the snow line.

Follow the clearance requirements below (refer to the Outline and System Drawings appendix):

- All parts of the generator set enclosure must be at least 60 inches (1524 mm) from any openings in walls of structures that may be occupied. Examples of wall openings include but are not limited to: operable windows, doors, dryer vents, fresh air intake for heaters, etc.
- The engine side and alternator side of the generator set must be located as follows:
 - One side (either engine or alternator) must be located not less than 18 inches (458 mm) from any structures having combustible walls. This space must be free of any obstructions for service access.
 - The opposite side must be located not less than 60 inches (1524 mm) from any structures having combustible walls. A minimum of 18 inches (458 mm) of unobstructed space is required for service access.
- The intake (cooling air inlet) side of the generator set must be located not less than 30 inches (762 mm) from any structures having combustible walls. This space must be free of obstructions to air flow and service access.
- The generator set must be located such that exhaust gases are not able to accumulate in an occupied area. The air discharge side must always be unobstructed and spaced a minimum of 60 inches (1524 mm) from any structures having combustible walls. A minimum of 36 inches (915 mm) must be free of any combustible items, and unobstructed for service access.
- The generator set must have enough room for installation, service, and maintenance.
- The generator set must be located to ensure ventilation openings are not blocked.
- Position the generator set so that cooling air is free to enter and leave the area.
- Locate and position the generator set so that prevailing winds carry exhaust gases and potential fuel leaks away from the house or occupied area.

Preparing the Generator Set Mounting Surface

Cummins recommends the generator set be installed on a non-combustible mounting pad (available as an accessory) or a poured concrete slab. The surface beneath the mounting surface must be properly prepared to minimize the risk of the generator set settling and causing undue stress on the fuel system or electrical connections. The surface preparation is the same when preparing the site for installing on the accessory mounting pad or poured slab.

Cummins recommends the generator set be installed above grade for easier maintenance, and lower risk of submersion in water.

1. Clear obstructions and make sure that there is adequate clearance for access to the site.
2. Ensure that the ground is stable and is not subject to flooding.
3. Level the ground, and make sure that the subgrade is compacted and settled. Local soil condition may dictate the need for addition of sub-base and base material layers above the subgrade. Consult with your local building officials for requirements and recommendations for your area.
4. Either pour a concrete slab or set an accessory mounting pad on the prepared surface. The poured concrete slab should be:
 - Constructed of concrete with a 28-day compressive strength of at least 2500 psi (17,200 kPa); typical bagged concrete mix meets this requirement
 - A minimum of 3 inches (76.2 mm) thick
 - At least 2 inches (50.8 mm) larger in length and width than the generator set base
5. Place the generator set on the pad and secure it to the mounting surface using the mounting spacers (provided) and appropriate fasteners. See the Securing the Generator Set to the Mounting Pad section for more information.

Lifting and Moving the Generator Set

WARNING

Heavy Load

The generator set is heavy. Handle with care.

Dropping the generator set can cause severe personal injury or death. Use appropriate lifting techniques to move the generator set. Keep feet and hands clear when lifting the generator set.

CAUTION

The generator set is shipped with oil in the engine crankcase. Keep the generator set upright.

Securing the Generator Set to the Mounting Pad

The generator set should be securely attached to either a poured concrete slab or prefabricated mounting pad (accessory pad) made of non-combustible material.

NOTICE

An accessory mounting pad is available that includes ½ -13 UNC x 1.25 inch mounting holes located in the proper location for these generator sets. Two hex head cap screws (½-13 x 3 inch long) and flat washers are needed with this accessory pad.

1. Position the two spacers (which were shipped with the generator set) appropriately on the generator set base.

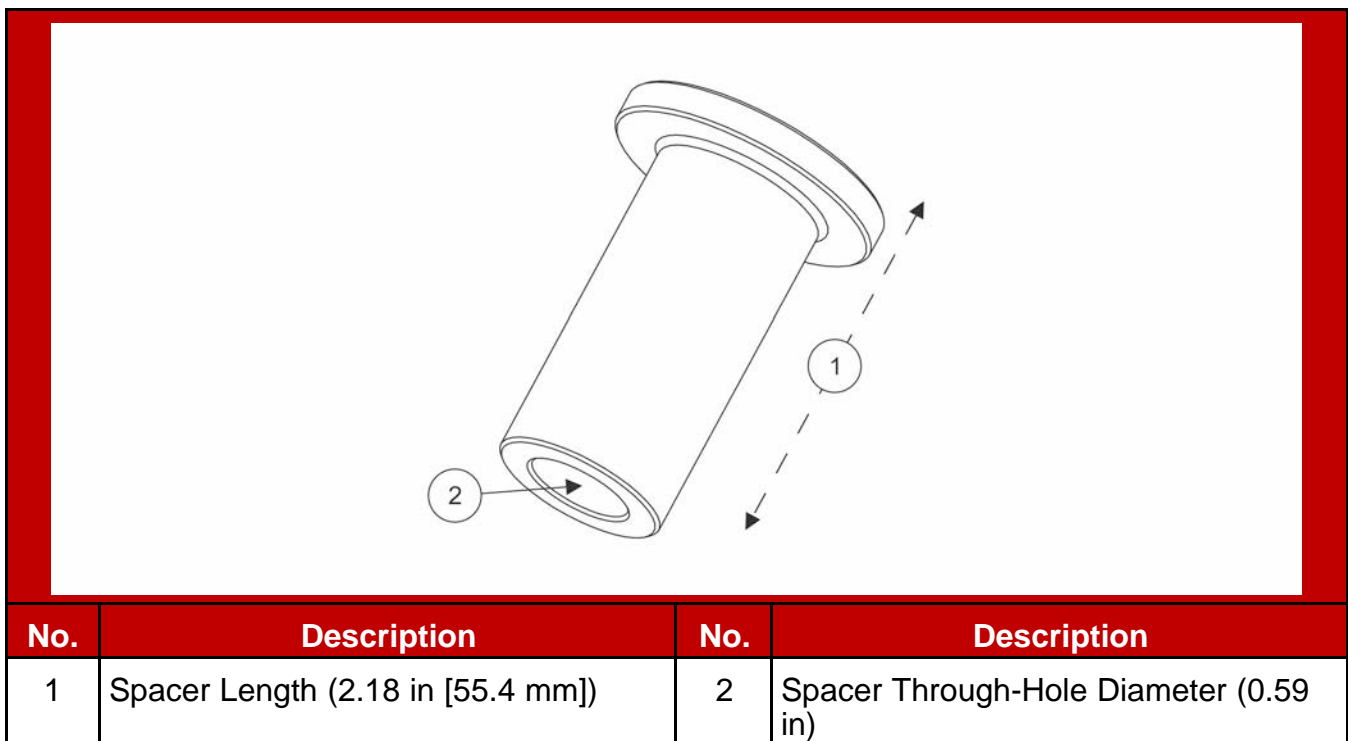

FIGURE 5. MOUNTING SPACER

2. *Prefabricated pad only:* Install the bolts into the prefabricated pad and tighten. Torque value: 37 ft-lb (50 Nm).
3. *Poured slab only:*
 - a. Mark the location for the anchor bolts with the generator set in place.
 - b. Install the anchor bolts per the manufacturer's recommendation for both embedment and tightening torque.

NOTICE

There are several styles of anchor bolts available. Follow the anchor bolt manufacturer's requirements for hole size and depth. The length of the anchor bolt must accommodate:

- The embedment length of the bolt into the pad
- The length of the spacer
- The thickness of the washer and
- The thickness of the nut (if used)

4. Install the chassis plugs in the generator set's lifting holes after the unit is in its final position.

4.2 Fuel Selection and Fuel System Connection

This generator set has a convertible fuel system. The generator may run on natural gas or propane, depending on the preferences of the owner. All generator sets come preconfigured from the factory for natural gas fuel. For more information on converting the fuel system type, see the Service Manual.

NOTICE

Fuel systems must be installed by qualified service technicians. Improper installation presents hazards of fire and improper operation, resulting in severe personal injury or property damage.

NOTICE

In some jurisdictions fuel system installations to the generator set must be performed by licensed or registered personnel. Check with the authority having jurisdiction for requirements.

⚠ WARNING

Gaseous fuels are flammable, explosive, and can cause severe personal injury or death. Do not smoke if you smell gas, are near fuel tanks for fuel-burning equipment, or are in an area sharing ventilation with such equipment. Keep flames, sparks, pilot lights, electrical arcs, arc-producing equipment and all other sources of ignition well away. Keep a type ABC fire extinguisher handy.

In all fuel system installations, cleanliness is extremely important.

- Make every effort to prevent fuel contamination from:
 - Moisture
 - Dirt

- Excess thread sealant
- Contaminants of any kind
- Clean all fuel system components before installing.

Gaseous-fuel supply system design, materials, components, fabrication, assembly, installation, testing, inspection, operation, and maintenance must comply with the applicable codes. See NFPA Standards No. 37, 54, and 58. If this is a seismic installation, refer to IBC codes and standards. Where seismic installation is required, there may be specific anchorage requirements for the generator set and other installed components.

Most codes require a manual shutoff valve ahead of a flexible fuel hose. The generator set includes electric (battery-powered) shutoff valves.

NOTICE

It is recommended that a shutoff valve be located near the generator set for emergency shut off or servicing the generator set. Follow applicable codes.

Until the generator set is connected, cap the fuel line stub-up at the generator set to prevent dirt from entering and gas from discharging if the gas supply shutoff valve is opened accidentally.

To determine the required capacity, refer to the Fuel Line Selection section.

Fuel Line Connections

⚠ WARNING

Fuel presents the hazard of fire or explosion that can result in severe personal injury or death. Do not smoke or allow any flame, spark, pilot light or other ignition sources near fuel or in the installation area. Read the important safety precautions in this manual.

1. Refer to the Outline and System Drawings appendix for the location of the fuel supply connection through the side of the generator set.
2. Install a flexible fuel hose, which must be used between the engine's fuel system and fuel supply line to protect the fuel system from damage caused by vibration, expansion and contraction. The fuel hose must be installed according to all applicable codes and standards.

Natural Gas Fuel System

⚠ WARNING

Fuel leaks can lead to explosive accumulations of gas. Prevent gas leaks and the accumulation of gaseous fuel in the event of a leak.

Requirements for a natural gas generator set are as follows:

TABLE 14. NATURAL GAS GENERATOR SET REQUIREMENTS

Component	Description
Gas	Pipeline quality
Fuel Supply	Adequate fuel supply to operate correctly and run at full load
Shutoff Valve	Manual
Fuel Pipe Size	<p>The length of the fuel supply pipe from the gas service entrance to the generator set must be known to determine the correct fuel pipe size. Refer to the charts in the Fuel Line Selection appendix.</p> <p>Iron pipe must be a minimum of schedule 40 subject to the authority having jurisdiction.</p>
Flexible Fuel Line	Protects the fuel system from vibration, expansion, and contraction. Must meet code requirements for application and be installed per manufacturer instructions.

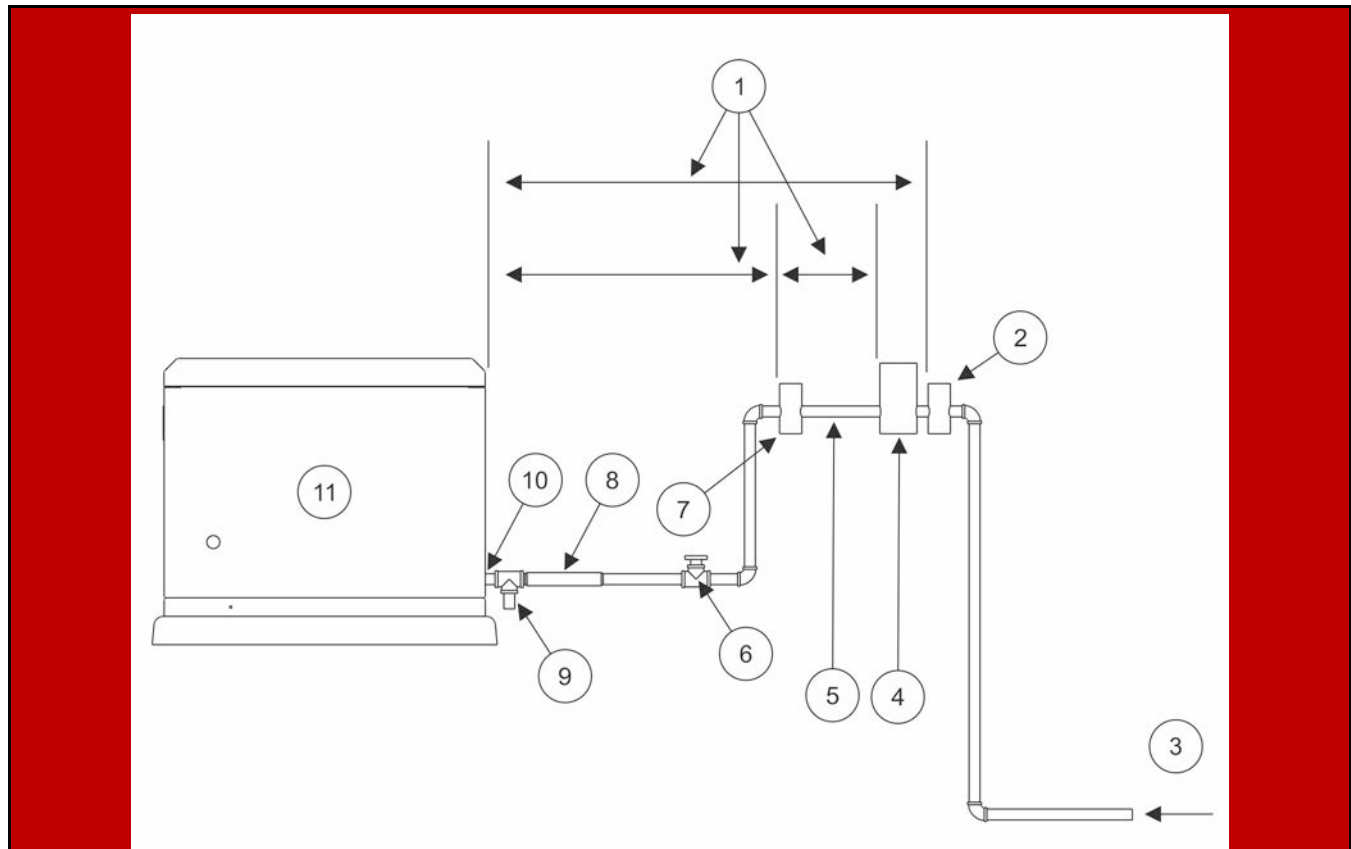

No.	Description	No.	Description
1	Distance as Required by Code and/or Component Suppliers	7	Secondary Service Pressure Regulator (If Required)
2	Primary Service Pressure Regulator	8	Flexible Fuel Line
3	Natural Gas Supply	9	Sediment Trap
4	Gas Meter	10	Fuel Line Connection at Generator Set
5	Note: A branch in the fuel line to the generator set may allow selection of a smaller diameter line size to the generator set and remainder of gas appliances.	11	Generator Set
6	Full Flow Manual Shutoff Valve		

FIGURE 6. TYPICAL NATURAL GAS INSTALLATION

Natural Gas Supply Line Size

See the Model Specifications section for fuel specifications (such as BTU/hr). The natural gas supply meter may need to be exchanged for a higher capacity meter to supply the additional gas consumed by the generator set.

To correctly size the fuel pipe, you must also take other loads operated from the fuel supply line into consideration, such as space heating and water heating equipment.

Use the total fuel requirement of the generator set and other connected appliances to determine the size of the fuel supply pipe. Use the tables and charts in the [Fuel Line Selection](#) appendix to determine the correct pipe size.

The installation site might require upgrading and repair of the gas supply system. Schedule an upgrade or repair to minimize power and gas supply interruptions.

Make sure the full load fuel supply pressure at the inlet to the generator set fuel shutoff valves is set between 3.5 - 12 inch water column (0.9 - 3.0 kPa) for all operating loads (no load to full load). Refer to the Model Specifications section.

See the Natural Gas Fuel System section for an example of a typical natural gas installation.

Propane Fuel System

WARNING

Fuel leaks can lead to explosive accumulations of gas. Propane sinks in air and can accumulate inside housings, basements, and other below-grade spaces. Prevent gas leaks and the accumulation of gaseous fuel in the event of a leak.

NOTICE

NFPA Standard No. 58 requires all persons handling and operating propane to be trained in proper handling and operating procedures.

TABLE 15. REQUIRED COMPONENTS IN A PROPANE VAPOR FUEL SYSTEM

Component	Description
Propane Tank	Make sure to identify and use the correct tank size based on fuel flow requirements and the lowest average temperature for your region. If the tank is sized incorrectly, the generator set could run out of fuel. Refer to the Minimum LPG Tank Size figure in the Fuel Line Selection appendix.
Shutoff Valve	Useful during installation or in the event of a leak (may be required to meet local codes).
Primary Pressure Regulator	Located at the tank outlet, the primary regulator reduces the tank pressure to the working pressure in the fuel supply line. Primary and secondary regulators must be properly matched for a safe and functional system. Consult with your propane supplier to ensure that the regulators are properly sized.

Component	Description
Secondary Pressure Regulator	Located near the generator set, the secondary regulator reduces the higher line pressure to a working pressure of 6 - 12 inch water column (1.5 - 3.0 kPa). Higher pressure before the secondary regulator is necessary to ensure that there is enough fuel available at the secondary regulator for a fully loaded generator set. Always install this generator set's service regulator above the expected snow line.
Fuel Line	Connects to the fuel supply. It must be sized properly using the propane fuel line sizing charts (see the Fuel Line Selection appendix). Installation must comply with all national, state, and local codes.
Flexible Fuel Line	Protects the fuel system from vibration, expansion, and contraction. Must meet code requirements for application and be installed per manufacturer instructions.

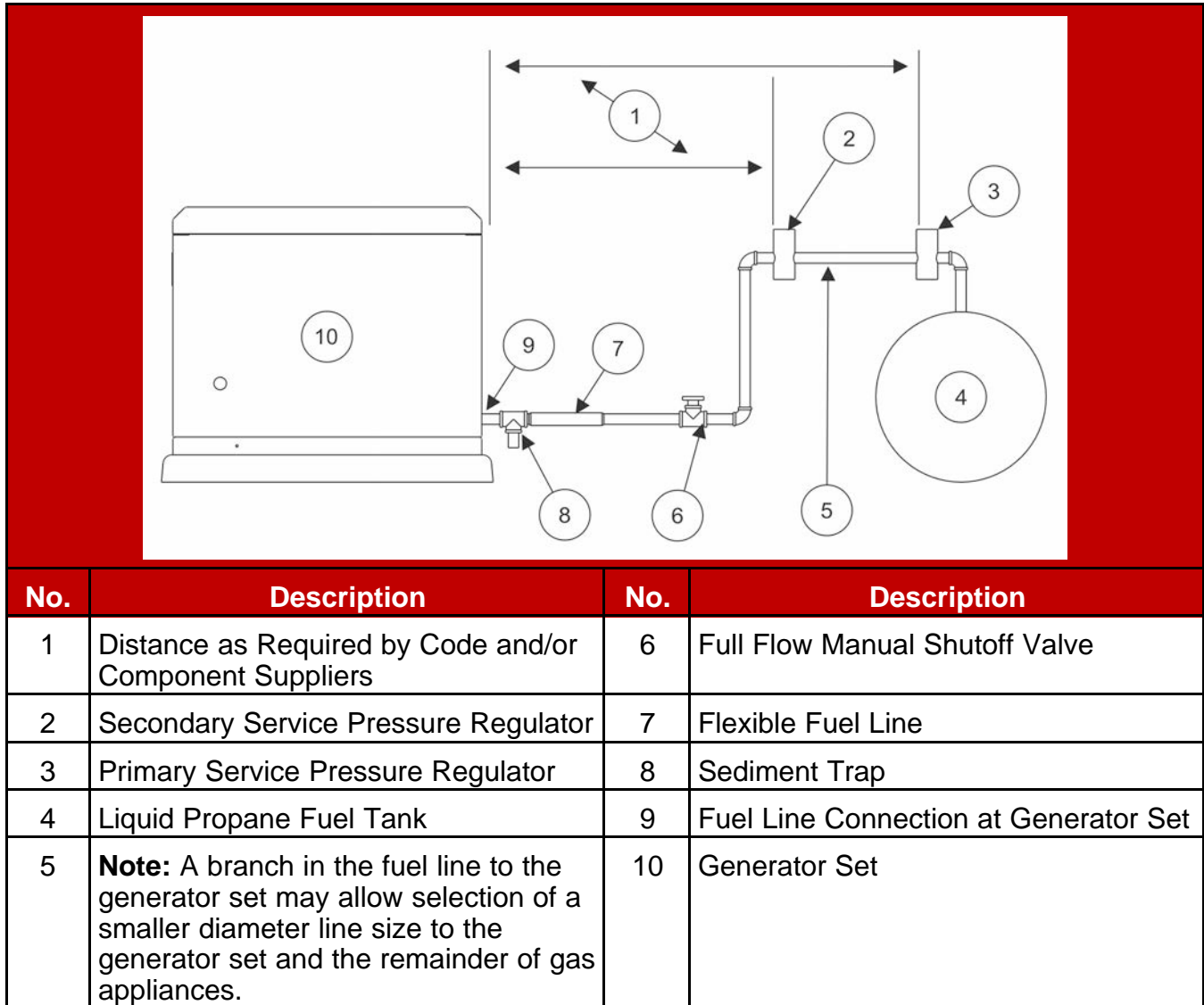

FIGURE 7. TYPICAL PROPANE INSTALLATION

Propane Fuel Requirements

⚠ WARNING

Propane presents the hazard of fire or explosion that can cause severe personal injury or death. Do not permit any flame, spark, arc-producing equipment, switch, pilot light, cigarette, or other ignition source near the fuel system. Keep an ABC type fire extinguisher nearby.

⚠ WARNING

Fuel leaks can lead to explosive accumulations of gas. Propane sinks in air and can accumulate inside housings, basements and other below-grade spaces. Prevent gas leaks and the accumulation of gaseous fuel in the event of a leak.

Use clean, fresh HD-5 grade propane or equivalent product consisting of at least 90% propane.

NOTICE

NFPA Standard No. 58 requires all persons handling and operating propane to be trained in proper handling and operating procedures.

NOTICE

Commercial propane may contain more than 2.5% butane, which can result in poor fuel vaporization and low tank pressure, resulting in poor engine starting and operation in below 32 °F (0 °C) temperatures.

Propane Tank Size

When propane is used, size the tank correctly to ensure successful generator set operation.

Considerations when figuring the proper propane tank size:

- Temperature is a critical factor that affects the size of the tank.
 - Ambient temperatures can affect how quickly liquid is converted to gas.
 - Generator set fuel consumption is the same regardless of the surrounding temperatures.
 - Colder weather climates require larger fuel tanks. Larger tanks have greater surface area, allowing more liquid propane to vaporize and maintain the required fuel rate.
 - Propane is stored as liquid. Keep the fuel tank at least 50% full to operate properly. Fuel tanks that are less than 50% full may not have the capacity to vaporize enough propane to operate the generator set and other LP appliances.
- Propane tanks are sized by their internal volume in gallons, not the amount of fuel they can hold (which is less).
- Propane tanks are generally filled to only 80% of their capacity. Therefore, a 500-gallon (1892 L) tank results in 400-gallon (1514 L) tank capacity.
- Low ambient temperatures affect the amount of fuel available from the propane tank.
- Approximately 60% of the fuel (in gallons) filled in the tank can be effectively used. Therefore, a 500-gallon (1892 L) tank results in 240-gallon (908 L) usable capacity.

To assist in the proper installation of the propane tank, follow the guidelines below.

- Consult your tank and propane supplier for assistance in all aspects of determining tank size, selection of components and installation requirements.
- Fit the propane tanks with a pressure reducing regulator before connection to the generator set to prevent fuel system damage.
- Locate the propane tanks and all other fuel system components at least 10 feet (3 meters) from any source of combustion (including the generator set). The fuel supplier or local code may require a larger distance between the tank and source of combustion.
- Install the propane tanks according to all national and local codes and standards, and as required by the fuel tank and fuel supplier.

Refer to the [Fuel Line Selection](#) appendix for propane figures and tables.

Propane Vapor Fuel Supply Line Size and Pressure

Fuel line size depends on the amount of fuel needed to run the generator set at full load at the distance the fuel must be moved.

To correctly size the fuel pipe, you must also take other loads operated from the fuel supply line into consideration, such as space heating and water heating equipment.

Use the total fuel requirement of the generator set and other connected appliances to determine the size of the fuel supply pipe. Use the tables and charts in the Fuel Line Selection appendix to determine the correct pipe size.

See the Model Specifications section for fuel system specifications, including fuel consumption and required fuel system pressure at the generator set.

See the Propane Fuel System section for a typical propane vapor installation.

See the Fuel Line Selection appendix for fuel capacity at given distances and pipe size.

NOTICE

Make sure the fuel supply pressure at the inlet of the generator set fuel regulator (at service port) matches the requirements in the Model Specifications section.

Converting the Fuel System Type

The generator set leaves the factory set up for natural gas. For operation on liquid propane vapor, the generator set must be converted by configuring the generator set control for propane and manually changing the fuel valve position from natural gas to propane.

1. To change the generator set control's fuel type from natural gas to liquid propane vapor:
 - a. From the Main screen, select **Menu**.
 - b. Press and hold the **Next** key on the Menu screen for at least 5 seconds to view the Config Menu.
 - c. Use the arrow keys to highlight "Config" and click the **Enter** key. The Generator Config screen appears.
 - d. Use the **Next** key to navigate to the **Fuel Type** field. Use the arrow keys to select the fuel type: NG (natural gas; default) or LP (liquid propane).

NOTICE

Do not change the number in the Config field.
--

NOTICE

The Rating field is not configurable by the user. Instead, it will be automatically populated based on the Config and Fuel Type field selections.
--

- e. Keep selecting the **Back** button to save the settings and return to the Main screen.

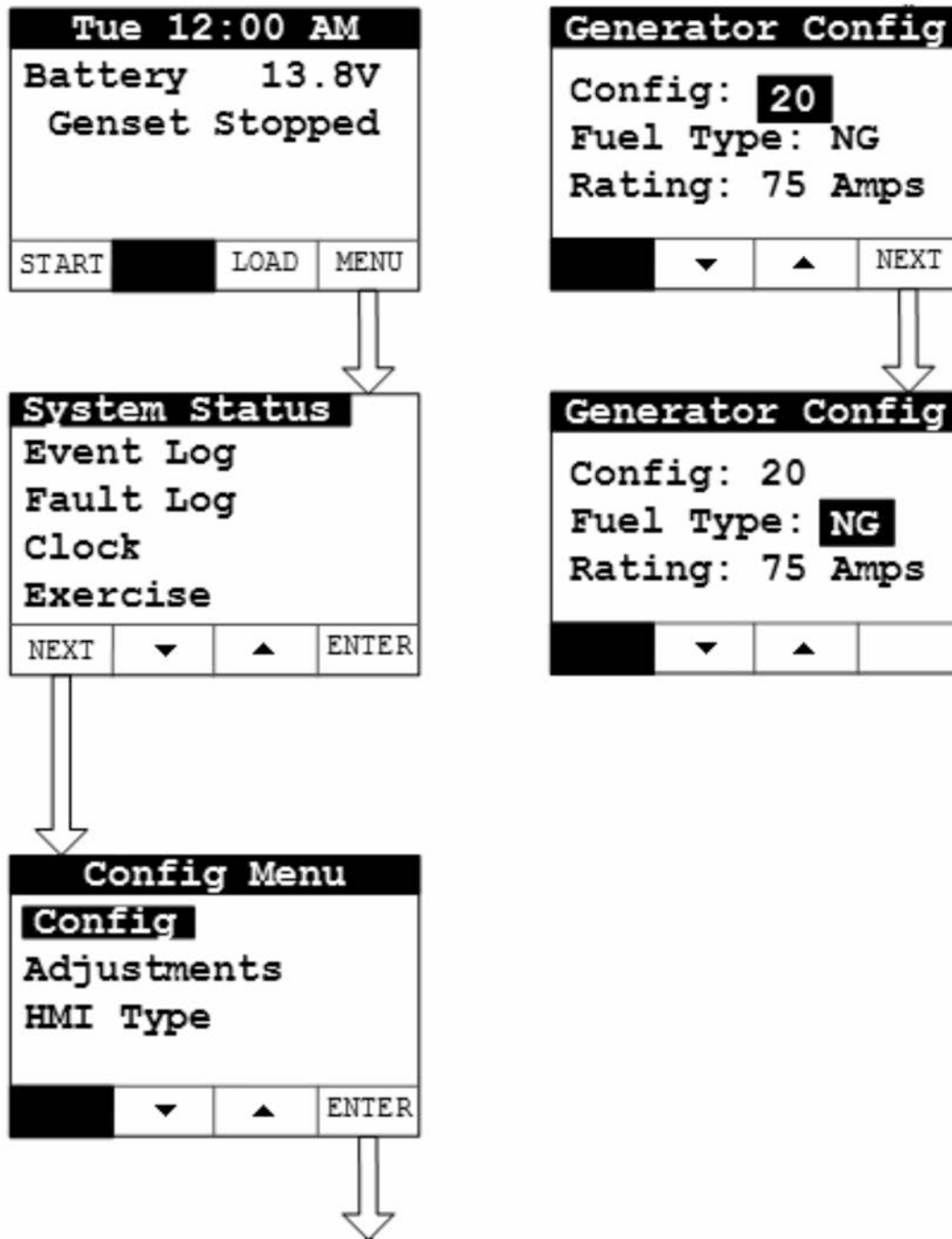

FIGURE 8. GENERATOR CONFIG SCREEN

2. Adjust the manual fuel selector to the LP setting:
 - a. Use a 6 mm external hex wrench to rotate the center section of the fuel valve.
 - b. Turn the center section clockwise until the detent is reached.
 - c. When you reach the detent, the required force to turn the valve will increase significantly - do not rotate center section of valve beyond this point.

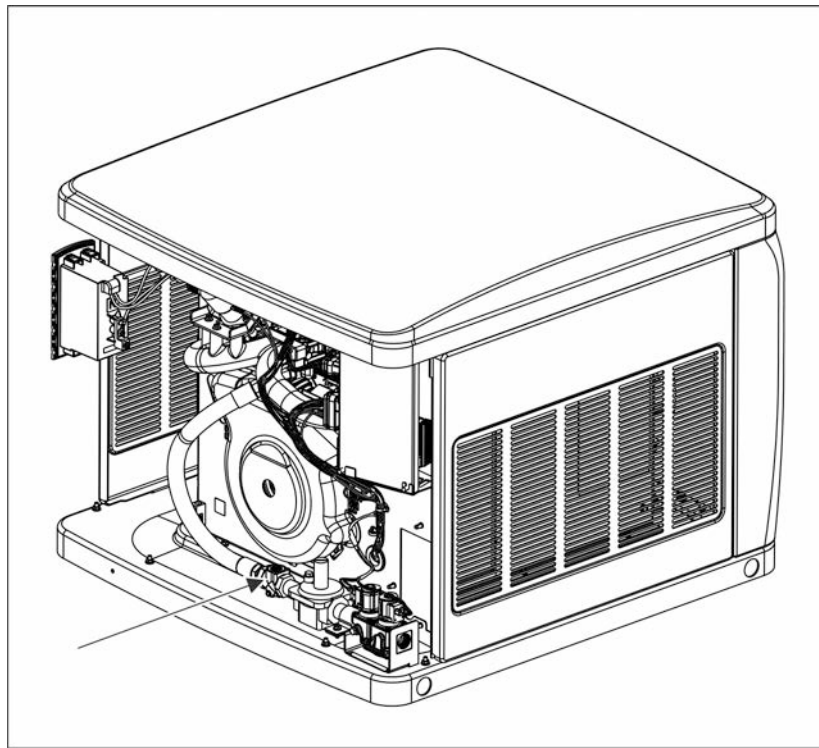
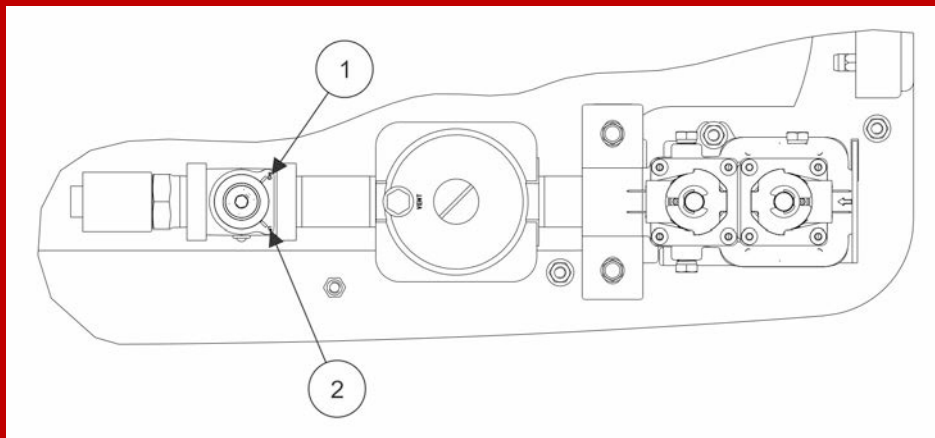

FIGURE 9. LOCATION OF FUEL SELECTOR VALVE



No.	Description	No.	Description
1	Natural Gas Fuel Position	2	Liquid Propane Vapor Fuel Position

FIGURE 10. MANUAL FUEL SELECTOR

Testing the Fuel System for Leaks

After assembly and before initial operation, all of the fuel system components must be tested and proven free of any leaks.

⚠ WARNING

Fuel presents the hazard of explosion or fire which can result in severe personal injury or death. Do not use an open flame to check for leaks. Do not smoke or allow any flame, spark, pilot light, arc-producing equipment, switch or other ignition sources around fuel or fuel components. Keep multi-class ABC fire extinguishers handy.

NOTICE

Follow any local codes and standards, as they may require a different method or documentation of a leak test.

Perform the following fuel piping system leak check:

1. After assembly and before initial operation of generator set, test all fuel system components as required per the National Fuel Gas Code (NFPA 54).
2. The National Fuel Gas Code requires that the generator set be isolated from the *piping* system by disconnecting it and capping the outlet prior to test. The test pressure required is the greater of 1.5 times the supply pressure or 3 psi (20.7 kPa) minimum.
3. After successfully completing the previous step, connect the generator set to the fuel piping system.
4. To verify that all connections from the fuel piping system to the generator set are free of leaks, conduct a bubble test using an approved leak detection solution (or equivalent method) with the system pressure of 0.8 to 1.0 psi (5.5 to 7.0 kPa).
5. Spray the bubble solution on all of the joints.
6. Inspect all of the joints and monitor the line pressure. If bubbles appear, there is a leak.
7. If any leaks are found, repair the joint or replace components as needed.
8. Verify the leak has been fixed.

NOTICE

The leak detection solution (that is, bubble solution) must be non-corrosive and be free of ammonia and chlorine.

4.3 Engine Exhaust

The exhaust system for this generator set is complete and was designed specifically for this generator set. Do not modify or add to the exhaust system of this generator set.

⚠ WARNING

Exhaust gas is deadly. Make sure that the exhaust system terminates away from building vents, windows, doors, and sheltered spaces that may not have ample fresh air ventilation.

⚠ WARNING

Engine discharge air and exhaust carry carbon monoxide gas (odorless and invisible) which can cause asphyxiation and death. Never use engine discharge air or exhaust for heating a room or enclosed space.

4.4 Electrical Connections

⚠ WARNING

Improper installation can lead to electrocution and damage to property. Electrical connections must be made by a licensed electrician.

NOTICE

Refer to regional codes and the National Electrical Code (NFPA 70) for all electrical installation requirements.

NOTICE

Class 1 wiring methods must be used for connecting the generator set.

Electrical Preparations

1. Run all wires through a single conduit (unless prohibited by the authority having jurisdiction).

NOTICE

Be sure to account for any needed accessories, such as a remote display, etc.

2. Connect the conduit to the generator set. Refer to the specific outline drawing in the Outline and System Drawings section for the size and location of the hole provided for electrical conduit connection. The existing hole may be increased in size to match conduit used.
3. Route and secure customer wiring along the generator set harness above the engine intake manifold, using wire ties.

AC Connections

WARNING

Automatic startup of the generator set during installation can cause severe personal injury or death.

Make sure the generator set is shut down and disabled:

- 1. Press the generator set's red STOP button on the local display to stop the generator set. Allow the generator set to thoroughly cool to the touch.***
- 2. Turn off and disconnect the battery charger from the AC source before disconnecting the battery cables.***
- 3. Disconnect the negative (-) cable from the battery and secure it from contacting the battery terminals to prevent accidental starting.***

For grounding and neutral connections, look for the following symbols on the generator set. The neutral connection is at the rear of the breaker box; the ground connection is inside the enclosure on the panel to the left of the breaker box.

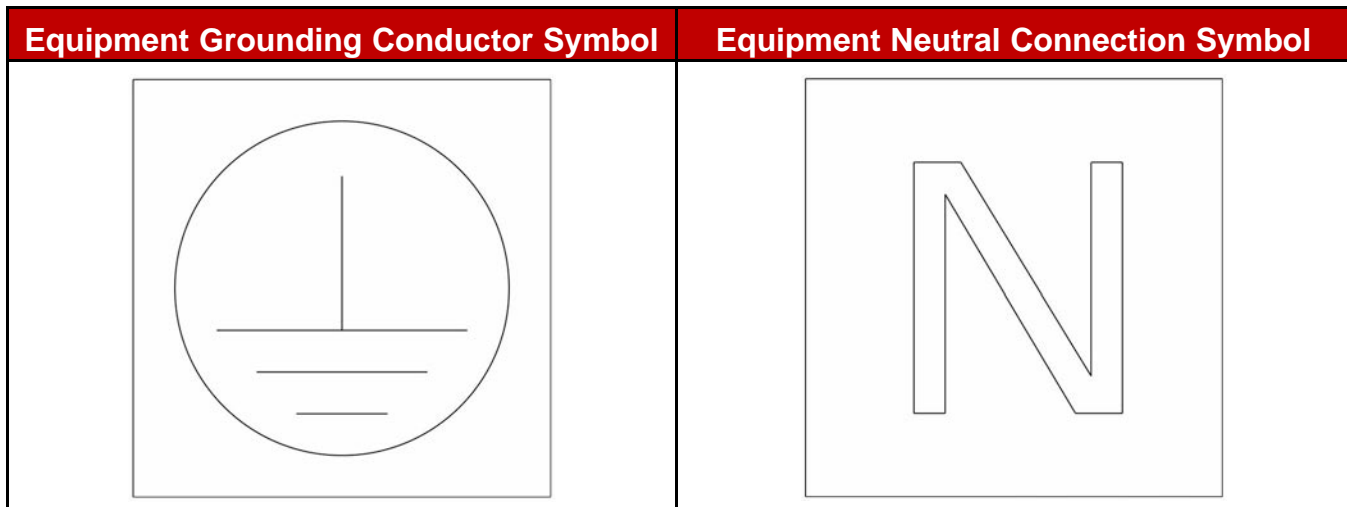

FIGURE 11. SYMBOLS ON CIRCUIT BREAKER BOX

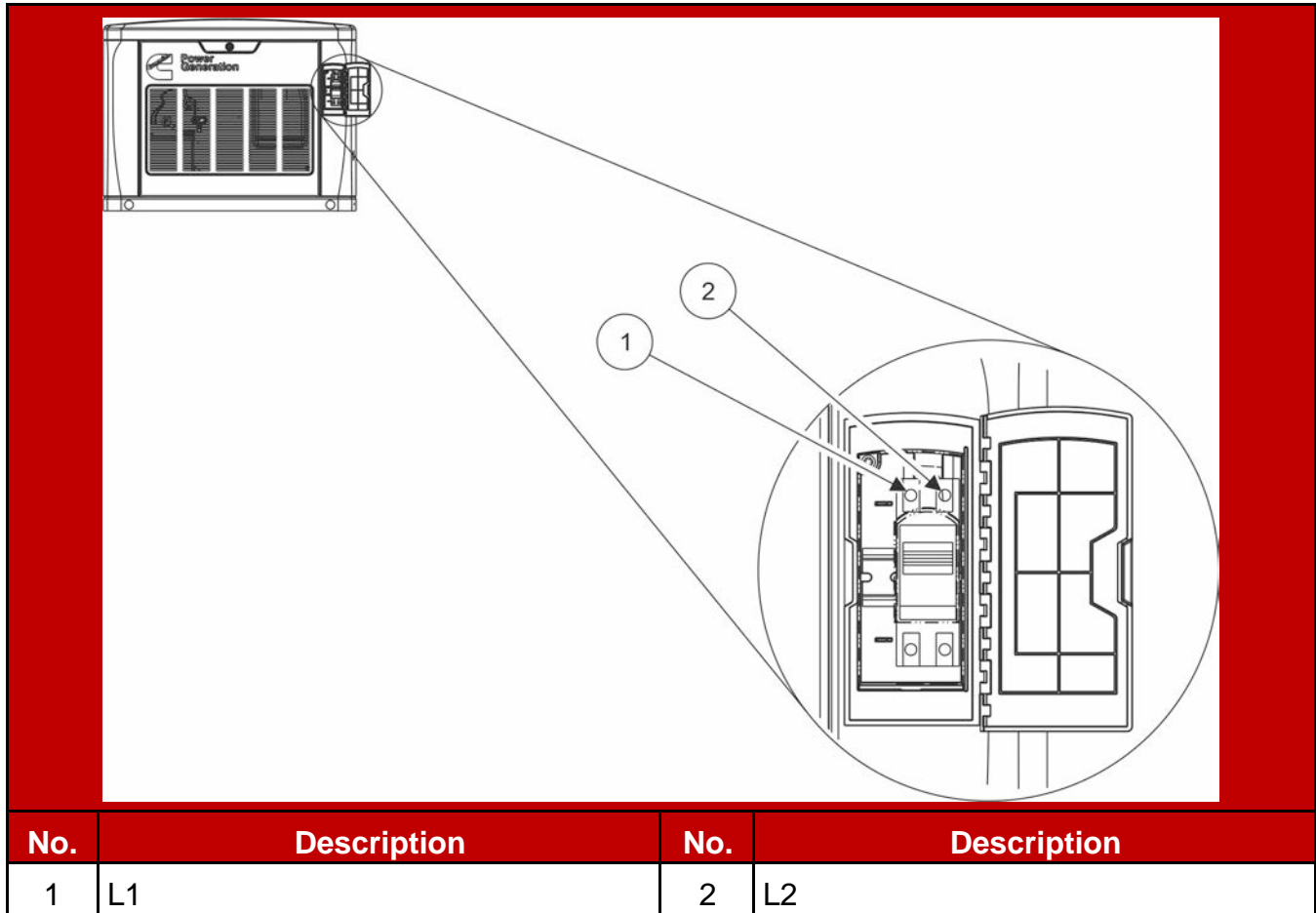

FIGURE 12. CIRCUIT BREAKER AC LOAD CONNECTIONS LOCATION

Make the AC load connections to the generator set in the circuit breaker box as follows:

1. Open the circuit breaker box door.
2. Place the circuit breaker handle in the OFF position.
3. Lift the top cover. Undo the two screws on top of the intake panel and remove the panel.
4. Route the load conductors through the access holes found at the bottom of the circuit breaker box.
5. Connect the conductors to the circuit breaker load side terminals. Torque the circuit breaker terminals to 45 in-lb (5 Nm).
6. Unless there is no utility source connected to ATS or house loads, remove the bonding jumper from the neutral lug on the back of the circuit breaker box to the equipment grounding lug as shown in [Figure 12](#). Refer to NFPA 70E or CEC.
7. Install the neutral line to the neutral lug found on the back of the circuit breaker box. Torque the neutral lug to 120 in-lb (13.6 Nm).
8. Install the ground line to the equipment grounding lug. Torque the equipment grounding lug to 120 in-lb (13.6 Nm).

9. Install the circuit breaker cover with the screw provided. Torque the pan-head screw to 12 in-lb (1.36 Nm).
10. Reinstall the intake panel.
11. Reinstall the two screws. Torque to 44 - 58 in-lb (5 - 6.6 Nm).
12. Close the lid and lock it if the installation is complete.
13. Close the circuit breaker box door.

Automatic Transfer Switch AC Connections

WARNING

Failure to use an approved transfer switch can lead to the electrocution of personnel working on the utility lines, damage to equipment, fire, or personal injury. An approved switching device must be used to prevent interconnection to the public utility.

Install the transfer switch in accordance with the appropriate RA series transfer switch owner manual.

Customer AC Connections

The customer supplied AC circuit is used to power the following components:

- Alternator heater (if applicable)
- Battery charger (standard)
- Battery heater (if applicable)
- Engine oil heater (if applicable)

The AC circuit must be 120 VAC, 20 Amp protected. The wires from this customer supplied circuit are terminated within the enclosure at the five place connectors labeled "Ground", "Line" and "Neutral". Follow regional regulations and applicable electrical codes for installation.

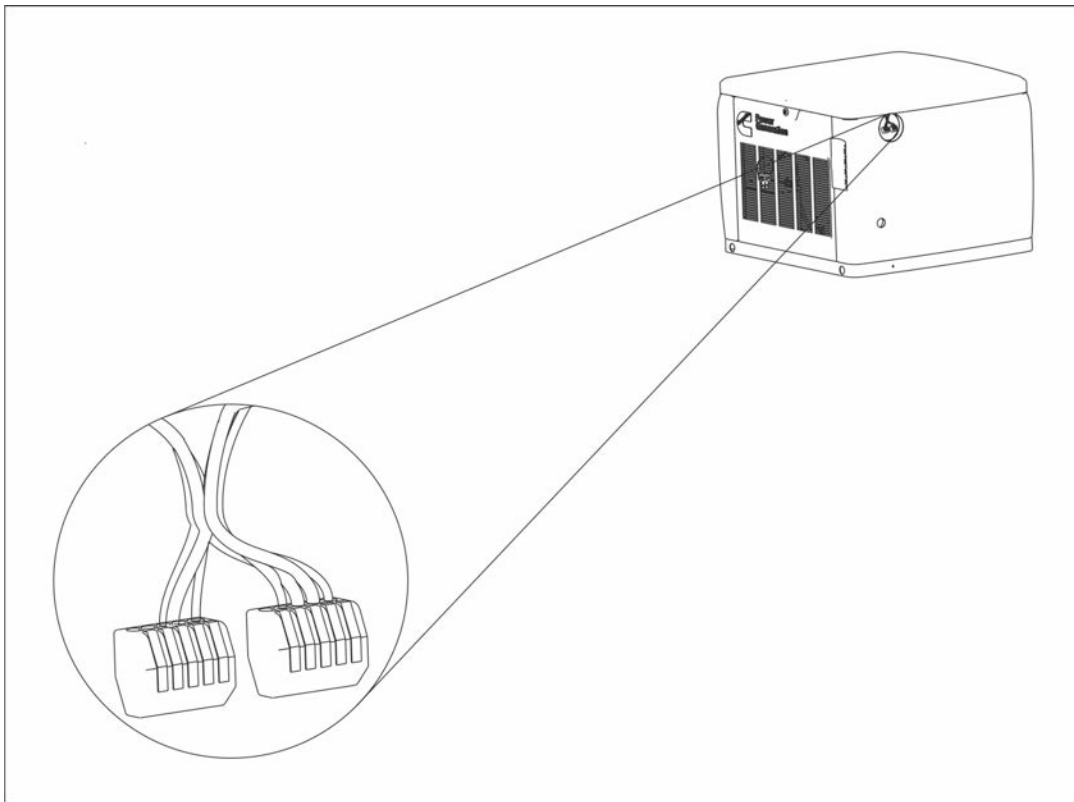

FIGURE 13. CUSTOMER AC CONNECTIONS

DC Connections

NOTICE

See the Wiring Diagrams appendix for DC customer connections.

Automatic Transfer Switch (ATS) DC Connections

⚠ WARNING

Failure to use an approved transfer switch can lead to the electrocution of personnel working on the utility lines, damage to equipment, fire, or personal injury. An approved switching device must be used to prevent interconnection to the public utility.

Install the transfer switch in accordance with the appropriate RA Series Transfer Switch Owner Manual.

The following image shows the location of the connectors in the generator set where the ATS DC control wires terminate. This is also the location of the connectors where load management control wires terminate.

NOTICE

Class 1 wiring methods should be used for connecting the generator set and transfer switch signal wiring.

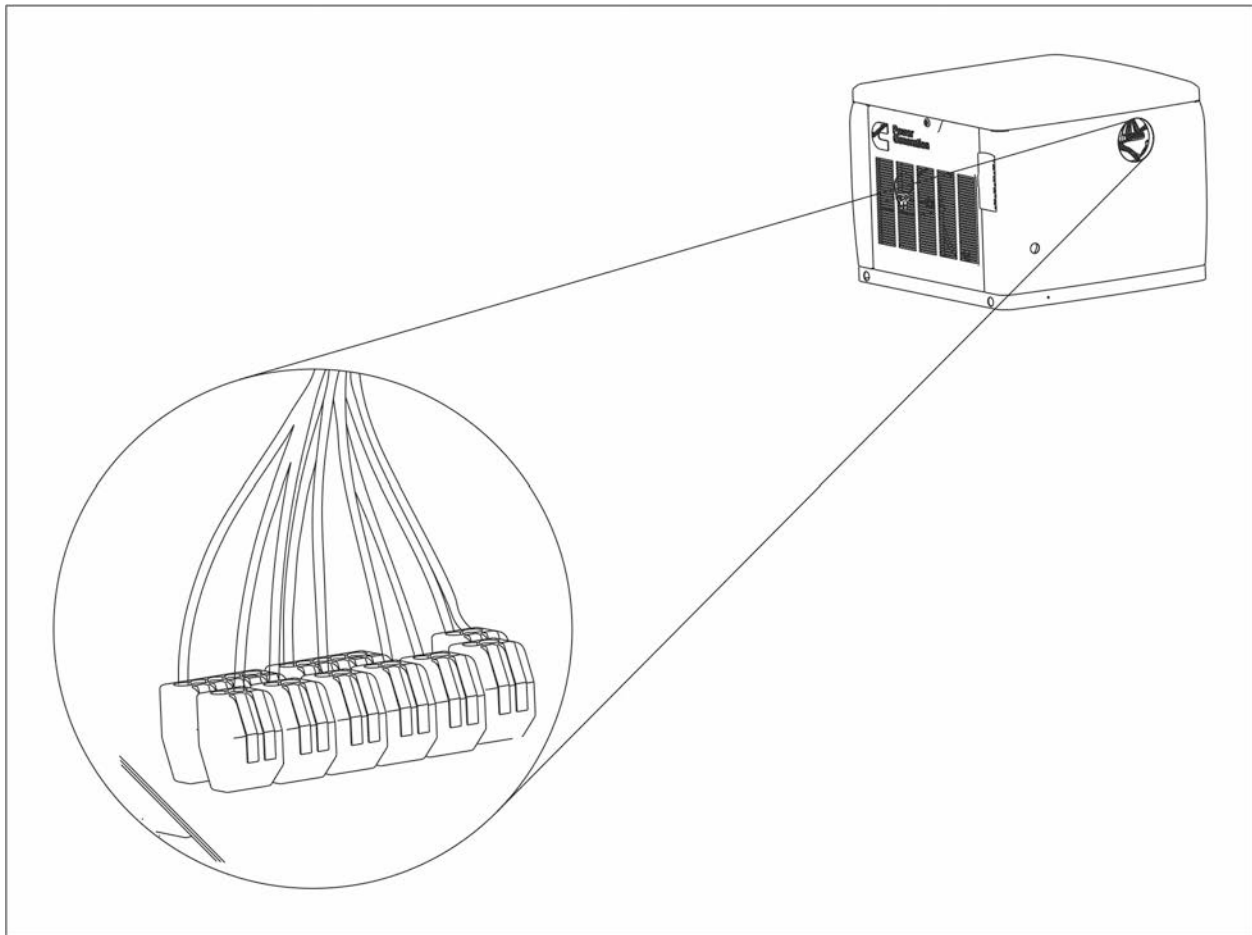

FIGURE 14. LOCATION OF CONNECTION POINTS FOR ATS DC CONTROL WIRES AND LOAD MANAGEMENT CONTROL WIRES

Refer to the Wiring Diagrams appendix for generator set to RA transfer switch DC customer connections.

Grounding

Use the Typical System Grounding One-Line Diagrams in this section to be sure that the generator set, transfer switch, power supply wiring and all connected electrical equipment are bonded to a common grounding point in accordance with the applicable codes and standards. Refer to local codes and standards for grounding procedures.

NOTICE

The generator set grounding terminal must be connected to the grounding terminal in the transfer switch. Do not provide a separate grounding rod for the generator set.

NOTICE

Generator set neutral is not typically grounded at the generator set, but at the common system grounding point.

⚠ WARNING

Contact with electrical equipment can result in severe personal injury or death. It is extremely important that bonding and equipment grounding be properly done. All metallic parts that could become energized under abnormal conditions must be properly grounded.

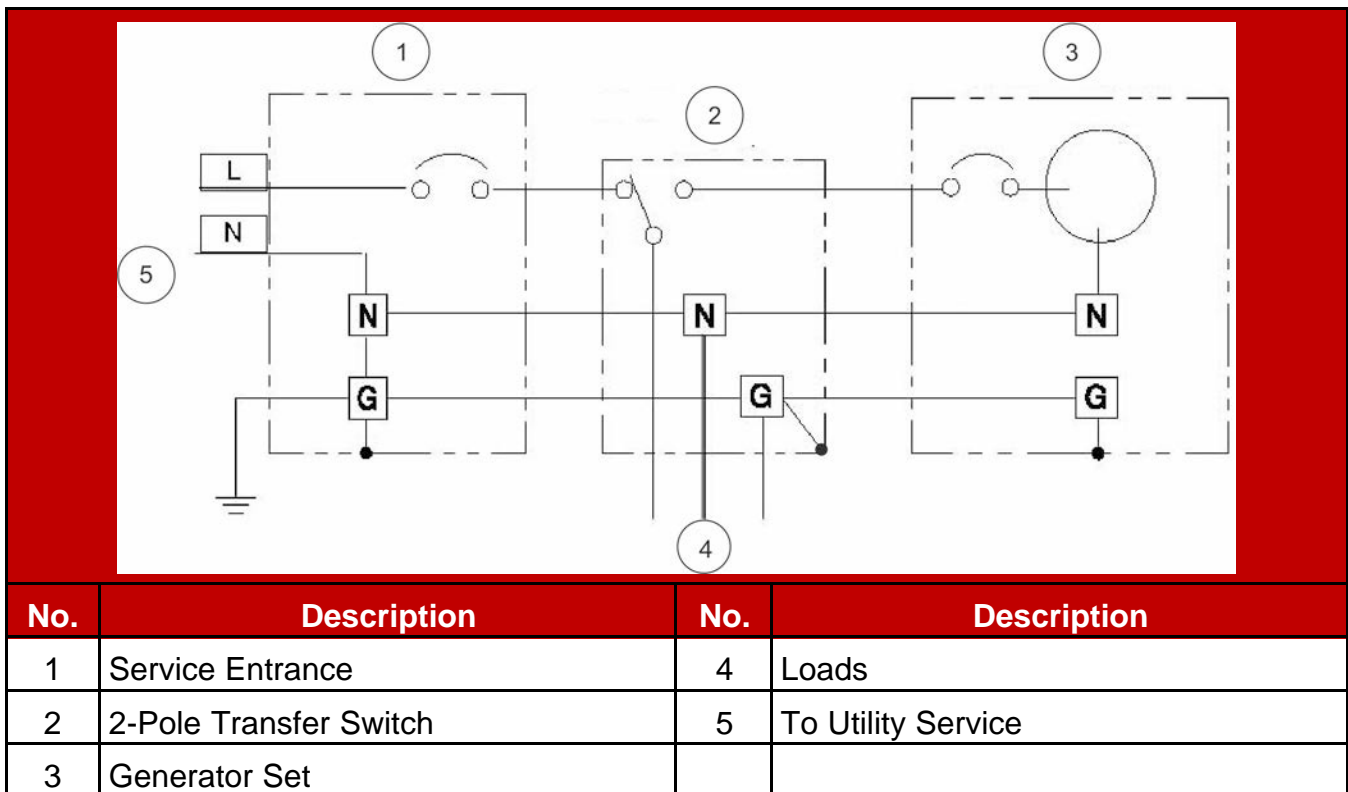

FIGURE 15. TYPICAL SYSTEM GROUNDING ONE-LINE DIAGRAM (SEPARATE SERVICE ENTRANCE AND 2-POLE TRANSFER SWITCH)

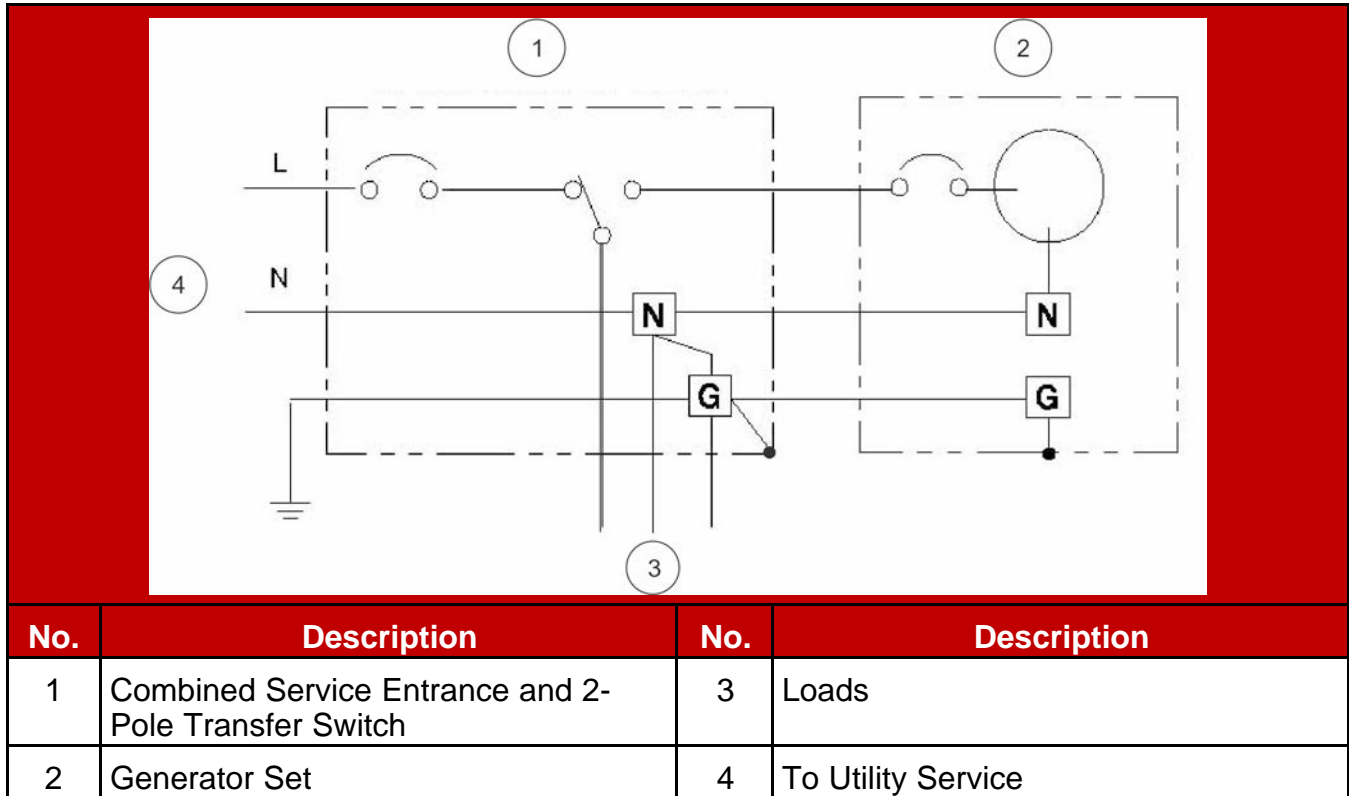

FIGURE 16. TYPICAL SYSTEM GROUNDING ONE-LINE DIAGRAM (COMBINED SERVICE ENTRANCE AND 2-POLE TRANSFER SWITCH)

Display Communication Wires

NOTICE

There are two unmarked connectors on the back of the display, either one may be used for connecting the display to the generator set.

Class 1 wiring methods should be used for the remote display and transfer switch communication conductors between the generator set and transfer switch.

See the Operator Manual for information regarding using the display to operate and monitor the generator set.

Load Management Wiring

See the Automatic Transfer Switch (ATS) DC Connections section for the location of the connectors (TB-1, TB-2, TB-3, and TB-4) in the generator set, which are used for load management control wire termination. Class 1 wiring methods should be used for installing load management devices.

Cummins offers a kit for load management wiring (A051C329).

Battery

The generator set requires a 12V battery for engine cranking and powering the electronic control system. When the generator set is running, the battery is charged from the engine-driven battery charger. When the generator set is not running, an AC powered battery charger is provided to keep the battery charged.

⚠ WARNING

To avoid injury, wear proper safety protection when working around batteries. Keep open flames and sparks away from the equipment.

⚠ WARNING

Automatic startup of the generator set during installation can cause severe personal injury or death. Make sure the generator set is shut down and disabled:

- 1. Press the generator set's red STOP button on the local display to stop the generator set. Allow the generator set to thoroughly cool to the touch.***
- 2. Turn off and disconnect the battery charger from the AC source before disconnecting the battery cables.***
- 3. Disconnect the negative (-) cable from the battery and secure it from contacting the battery terminals to prevent accidental starting.***

To connect the battery:

1. Connect the battery cables to the battery with the positive (+) cable first. Immediately cover the battery post and terminal with the red terminal cover provided on the battery cable.
2. Connect the negative (-) cable to the battery's minus terminal.

Refer to the Model Specifications section for battery specifications.

An optional thermostatically controlled battery heater is available for more reliable starting.

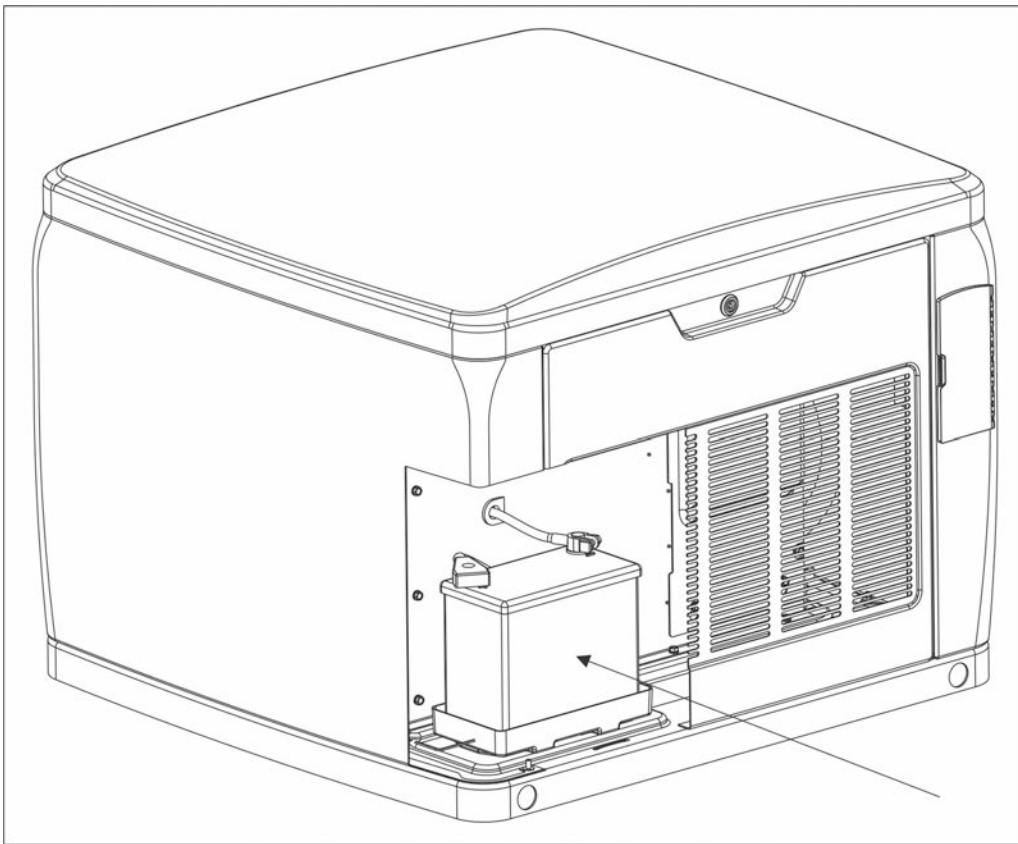

FIGURE 17. BATTERY LOCATION

This page is intentionally blank.

5 Startup and Configuration

5.1 "Establishing Communications" Message

NOTICE

Once the battery is connected to the generator set and any display button is pressed, the local display shows an "establishing communications" message for approximately 5 seconds. (This may take longer if the signal integrity is poor between the control and display due to a bad wire or Electro-Magnetic Interference [EMI].) Once communication is established, the display shows the HOME screen.

The "establishing communications" message will also be displayed whenever the control is brought out of "sleep" mode by pressing any button on the display. Sleep mode is entered after 30 minutes without utility or generator set power to preserve battery energy since the battery charger will not have AC power. The 30-minute timer is reset with any button press on the display.

5.2 "Clock Setup" Screen

NOTICE

The Clock needs to be reset whenever the battery power is lost or disconnected, or the control has entered "sleep" mode. Sleep mode is entered after 30 minutes without utility or generator set power to preserve battery energy since the battery charger will not have AC power. The 30-minute timer is reset with any button press on the display.

NOTICE

The optional Remote Monitoring System (RMS) uses the generator set's clock. The clock must be set accurately for the RMS to function properly.

To set up the generator set clock for the current date and time:

1. From the Main screen, select **Menu**.
2. Use the arrow keys to highlight **Clock**. Select the **Enter** key.
3. Use the arrow keys to set the time and date.

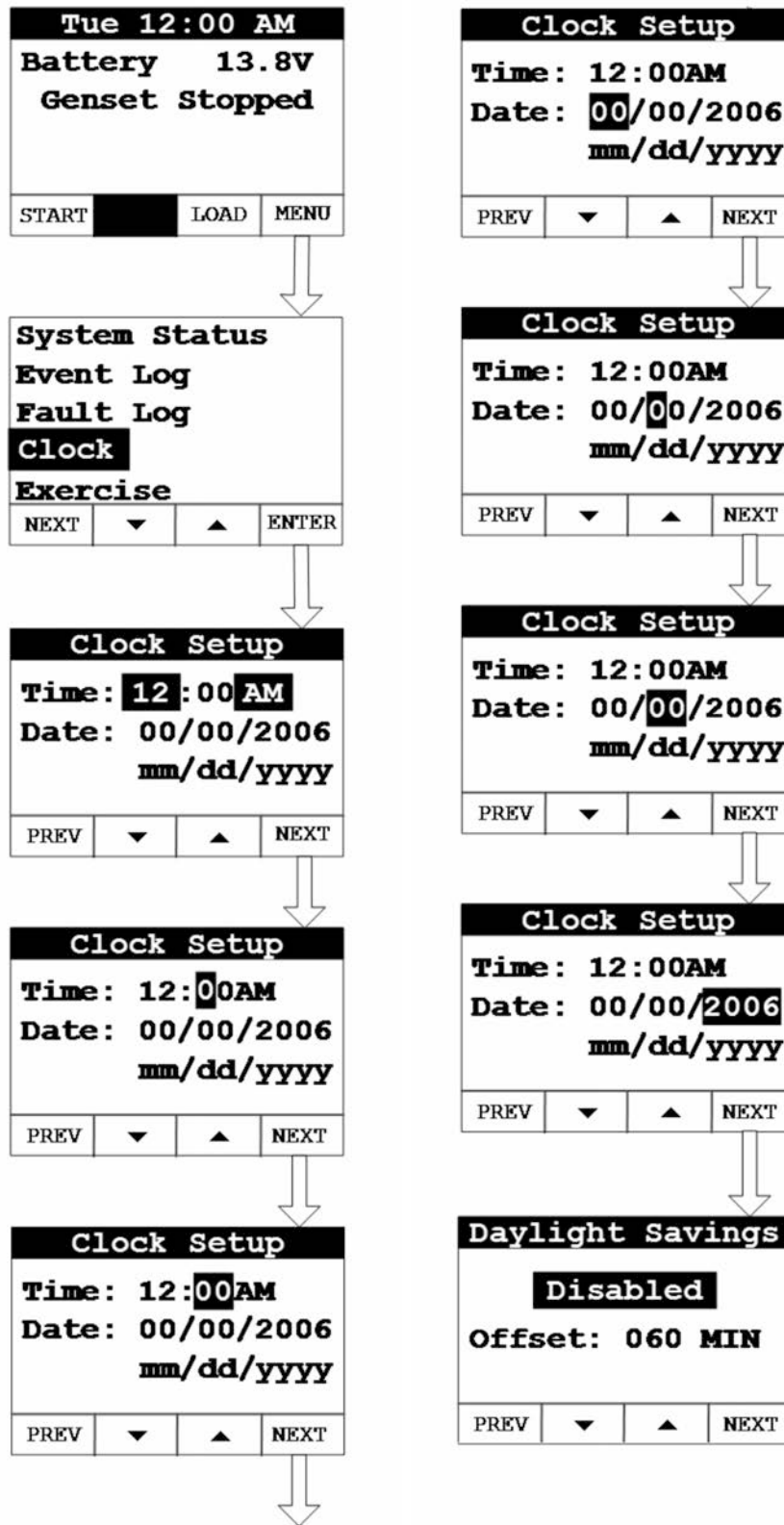

FIGURE 18. CLOCK SETUP SCREEN

4. Select the **Next** key to go to the Daylight Savings screen.

5. Use the arrow keys to enable/disable Daylight Savings. If enabling, select the **Next** key to highlight the **Offset** field.



FIGURE 19. DAYLIGHT SAVINGS TIME (ENABLED)

6. Use the arrow keys and **Next** key to set the offset value for Daylight Savings time.

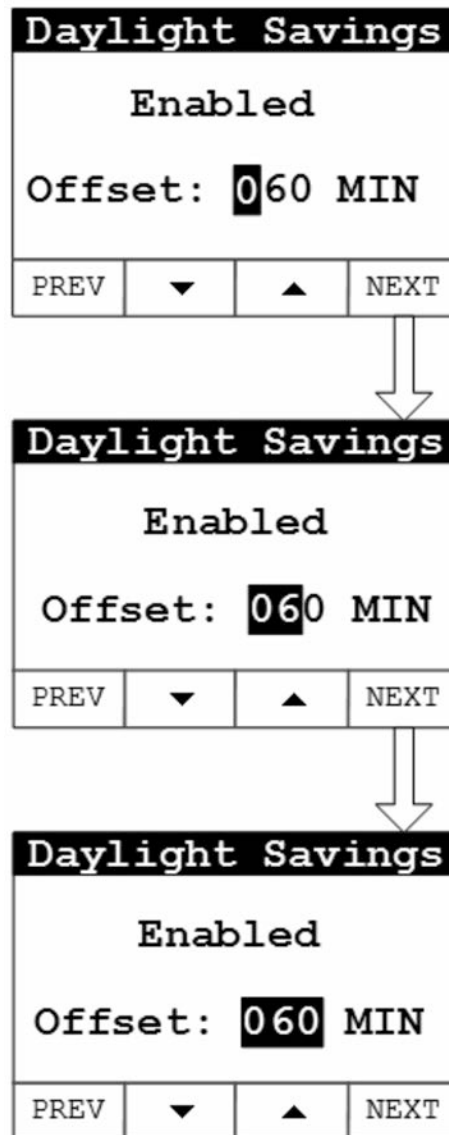
**FIGURE 20. OFFSET VALUE**

7. Select the **Next** key to go the screen that is used to set up when Daylight Savings should start. Use the arrow keys and **Next** key to set Month (1 – 12), Week (0 – 5), Day (Sun – Sat) and Hour (12AM – 12PM).

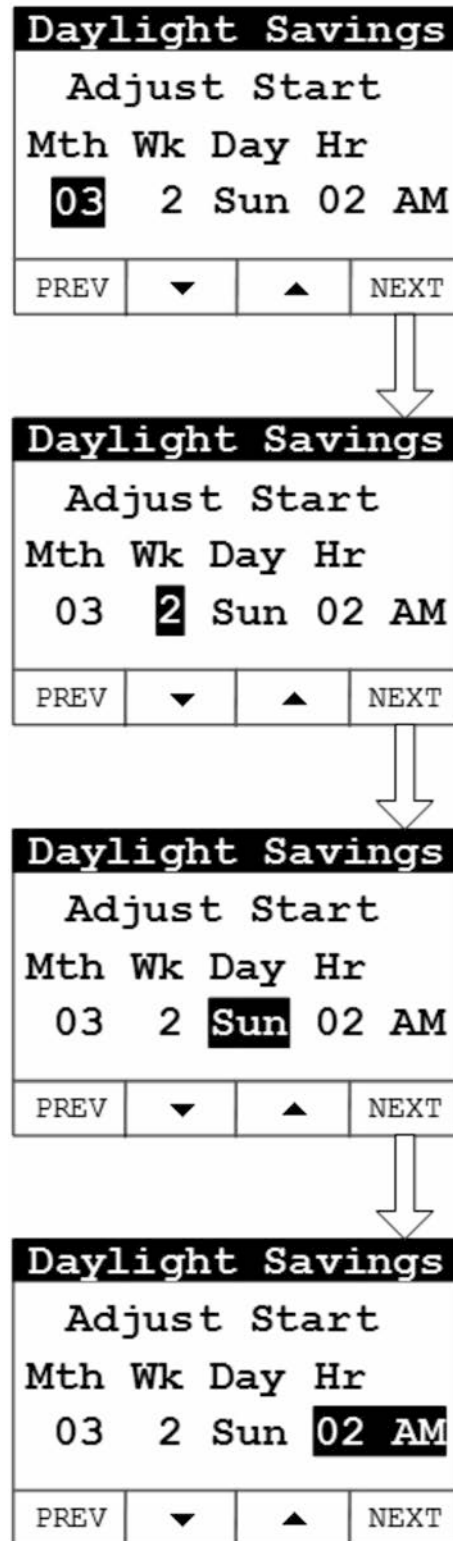

FIGURE 21. DAYLIGHT SAVINGS TIME (START TIME SETUP)

8. Select the **Next** key to go the screen that is used to set up when Daylight Savings should end. Use the arrow keys and **Next** key to set Month (1 – 12), Week (0 – 5), Day (Sun – Sat) and Hour (12AM – 12PM).

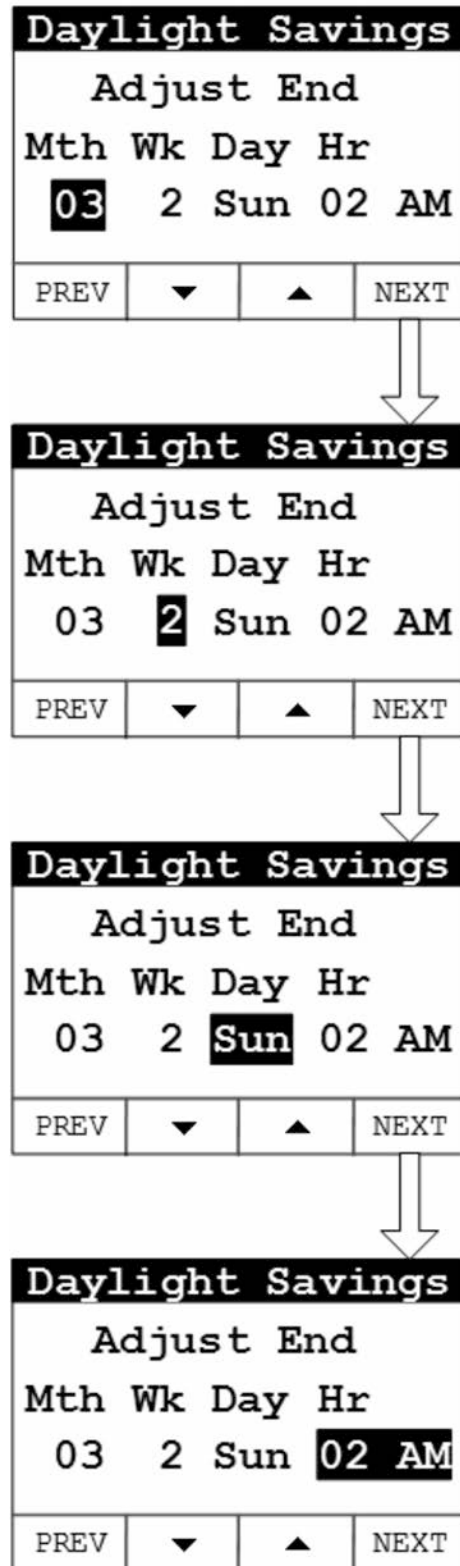

FIGURE 22. DAYLIGHT SAVINGS TIME (END TIME SETUP)

9. Keep selecting the **Back** button to save the settings and return to the main screen.

5.3 "Exercise" Screen

When installing an RA series transfer switch, follow these steps to configure the Exercise mode in the generator set's local display or remote display.

NOTICE

Exercise settings need to be reset whenever battery power is lost or disconnected, or the control has entered "sleep" mode.

NOTICE

Sleep mode is entered after 30 minutes without utility or generator set power to preserve battery energy since the battery charger will not have AC power. The 30-minute timer is reset with any button press on the display.

To set up the exercise function:

1. From the Main screen, select **Menu**.
2. Use the arrow keys to highlight **Exercise**. Select the **Enter** key.

NOTICE

If the time and date have not been set, a pop-up will appear that says, "Set Valid Date and Time".

3. Use the arrow keys to enable or disable the **Crank Exercise** feature. Select the **Next** key to go to the **Exercise Time** field. See the Exercise Sequences section in the operator manual for more information.

NOTICE

When the Crank Exercise feature is enabled, an exercise command will cause the engine starter to engage and rotate the engine, but will not allow the engine to start. This feature allows the control system to monitor critical generator set systems without running the engine. When Crank Exercise is enabled, the generator set's exercising will alternate between the Crank Exercise sequence and the normal exercise sequence (that is, engine running) at scheduled times.

4. Use the arrow keys to set how long the generator set will exercise (from 1 to 20 minutes). Select the **Next** key to go to the **Exercise** field. The Exercise Sched screen appears.
5. Use the arrow keys to set how often the generator set will exercise. The frequency selections are:
 - Weekly
 - Bimonthly
 - Monthly

- Never

Select the **Next** key to go to the date and time fields.

6. Use the arrow keys to set the day and time the generator set will be exercised. Select the **Next** key to highlight the **Exercise Now** field.
7. Select either arrow key to start the Exercise Now function.

NOTICE

Initiating the Exercise Now function will cause the generator set to start immediately and run for the amount of time indicated by the Exercise Time field, or run the Crank Exercise sequence. The ATS does not transfer to generator power during exercise mode. Normally scheduled exercise events will occur after the completion of the immediate exercise event.

8. Keep selecting the **Back** button to save the settings and return to the Main screen.

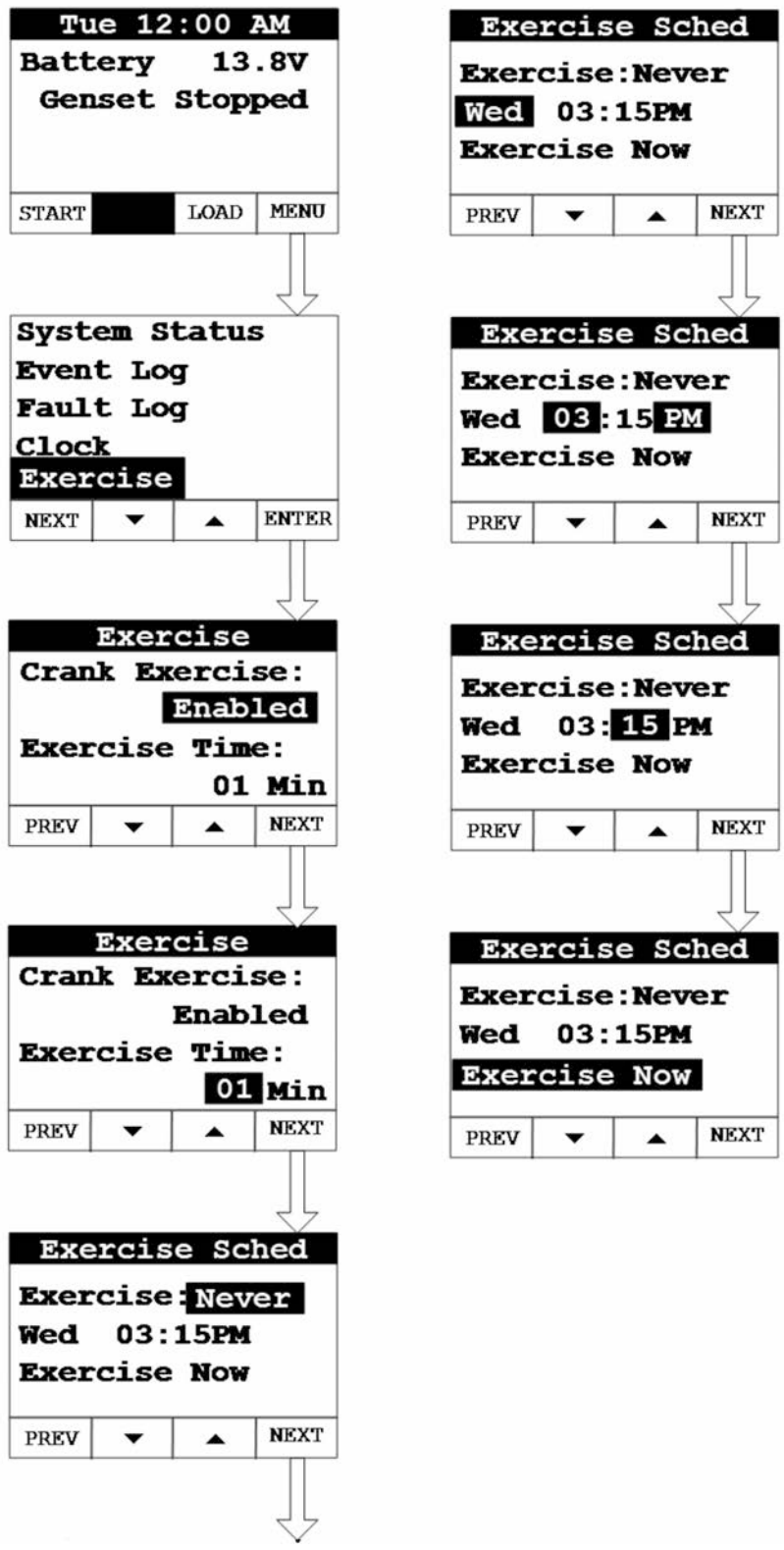

FIGURE 23. EXERCISE SETUP SCREEN

5.4 "Brightness and Contrast" Screen

To adjust the brightness and contrast of the display:

1. From the Main screen, select **Menu**.
2. Use the arrow keys to highlight **Display Setup**. Select the **Enter** key.
3. Use the arrow keys to set brightness and contrast for the display.
4. Keep selecting the **Back** button to save the settings and return to the Main screen.

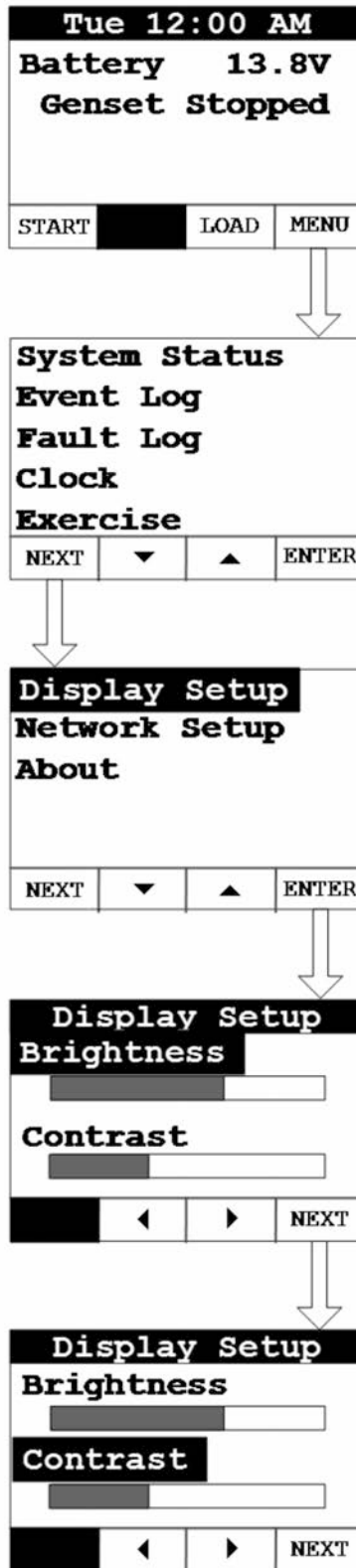

FIGURE 24. BRIGHTNESS AND CONTRAST SCREEN

5.5 "About" Screen

To retrieve information about the display:

1. From the Main screen, select **Menu**.
2. Use the arrow keys to highlight **About**. Select the **Enter** key.

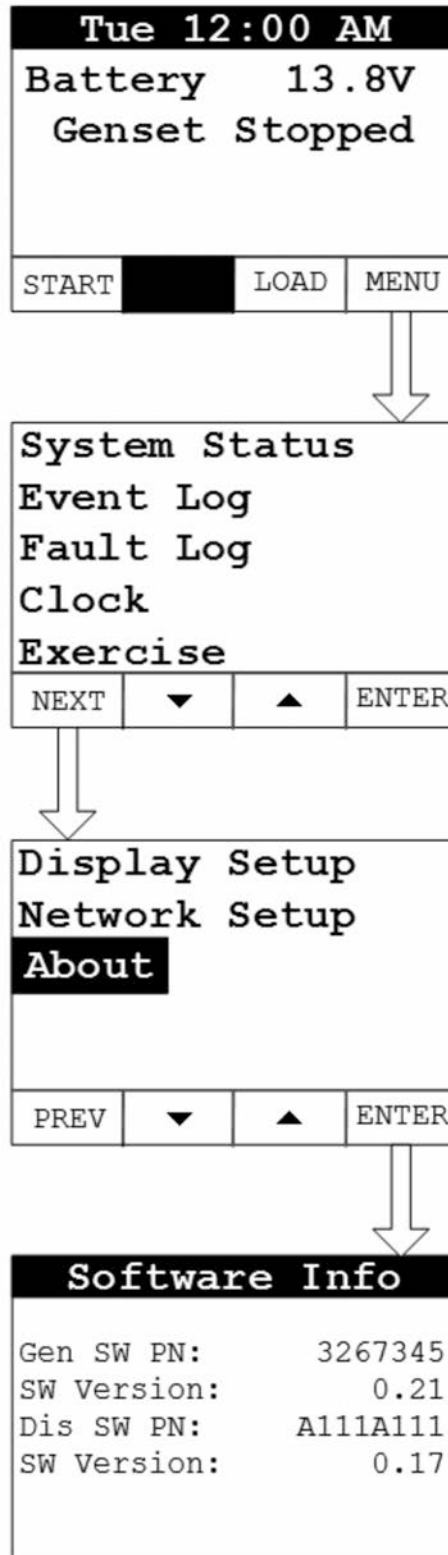

FIGURE 25. ABOUT SCREEN

5.6 "Event Log" Screen

To retrieve information from the Event Log:

1. From the Main screen, select **Menu**.
2. Use the arrow keys to highlight **Event Log**. Select the **Enter** key.
3. Use the arrow keys to navigate through the Event Log.
4. Keep pressing the **Back** button to return to the Main screen.



FIGURE 26. EVENT LOG SCREEN

5.7 "Fault Log" Screen

To retrieve information from the Fault Log:

1. From the Main screen, select **Menu**.
2. Use the arrow keys to highlight **Fault Log**. Select the **Enter** key.
3. Scroll through the fault log using the up and down double-arrows. Each screen provides a brief description of the fault, the fault code number, the engine hours and the time and date of the fault.

NOTICE

If there are no faults recorded, the "No Stored Faults" screen will appear.
--

4. Keep pressing the **Back** button to return to the Main screen.



FIGURE 27. FAULT LOG SCREEN

5.8 "System Status" Screen

To retrieve system status:

1. From the Main screen, select **Menu**.
2. Use the arrow keys to highlight **System Status**. Select the **Enter** key.
3. Keep pressing the **Back** button to return to the Main screen.



FIGURE 28. SYSTEM STATUS SCREEN

5.9 "Mode" Screen

⚠ WARNING

To prevent unexpected starts from remote devices, disable Remote mode and disconnect the connector on the back of the local display wired to any remote mounted displays.

When Remote is set to Enabled via the local display, the "Remote On" LED on the front of the display will illuminate indicating that the control will accept start commands from remote displays or remote monitoring systems including a web page or cell phone app.

NOTICE

The Remote function can only be activated (that is, enabled) from the local display.

When Standby is on or set to Enabled, the “Standby On” LED on the front of the display will illuminate indicating the control will start the generator set in response to a utility power outage. Standby can be turned on at the local display. It can also be enabled with a remote display, web page, or a cell phone app if Remote has already been enabled at the local display. The Standby function **cannot** be enabled remotely unless the Remote function is on. A manual Start or Stop event will disable the Standby function. (If the manual Stop event is performed at the local display, the Remote mode will also be disabled.)

1. To enable or disable the Remote and Standby modes on the **LOCAL** display:
 - a. From any screen, select the **Mode** key to get to the Mode screen.
 - b. Use the arrow keys to enable or disable the Remote mode. Select the **Next** key to go to the next screen.
 - c. Use the arrow keys to enable or disable the Standby mode.

NOTICE

Whenever Standby is enabled, the Remote mode will also automatically be enabled.

- d. Keep pressing the **Back** button to save the settings and return to the Main screen.

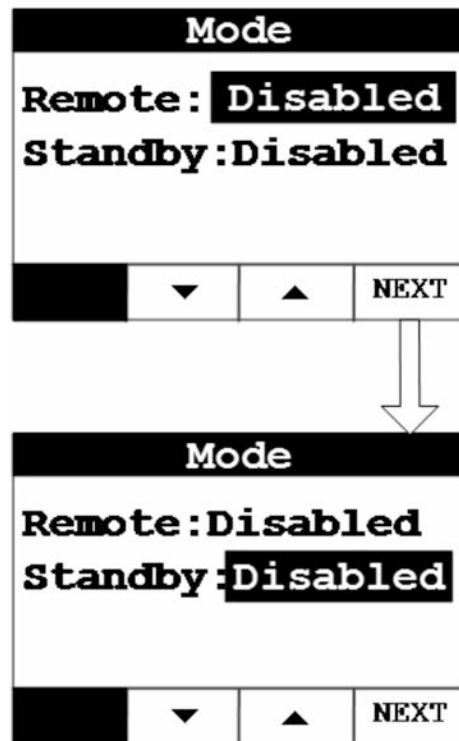

FIGURE 29. MODE SETUP SCREEN (LOCAL DISPLAY)

2. To enable or disable the Standby mode on the **REMOTE** display:

NOTICE

Remote must be enabled before Standby mode can be changed from the Remote display. If Remote mode is not enabled, Standby will remain disabled and cannot be changed.

- a. From any screen, select the **Mode** key to get to the Mode screen.
- b. Use the arrow keys to enable or disable the Standby mode.
- c. Keep pressing the **Back** button to save the settings and return to the Main screen.



FIGURE 30. MODE SETUP SCREEN (REMOTE DISPLAY)

5.10 Automatic Load Management

NOTICE

The capability to automatically add or remove specific electrical loads from the generator set requires that load management devices be wired to the generator set load management outputs.

When the generator set is started automatically in Standby mode due to a loss of utility or manually by the operator, the control will energize all four load management outputs, disconnecting the associated loads from AC power. Once the transfer switch transfers to generator set power, the generator set control will evaluate the total load on the generator set versus a set point programmed into the control (80% of rated).

If the generator set's total load is below the set point, the generator set control will sequentially add the highest priority managed load every three minutes. Managed loads will continue to be added as long as the size of the next priority load to be added won't increase total generator set load above the set point. The control measures and stores the size of each managed load in its memory. Load priorities are in the following order:

- Priority #1: load control 1
- Priority #2: load control 2
- Priority #3: load control 3
- Priority #4: load control 4

If the load on the generator set is reduced at any time to below the set point, the control will add the next highest priority managed load in three minutes provided it does not increase the total generator set load above the set point.

If the load on the generator set exceeds 95% of its rating, the generator set control will begin disconnecting the lowest managed priority loads in sequence every second until the load on the generator set is below 95% of its rating.

Priority #1 load is always the first added and the last disconnected; therefore, it should be wired to the managed load deemed most critical to the homeowner. Priority #2 load cannot be added before priority #1 load, nor can it be disconnected before priority #3 or #4, etc.

5.11 Manual Start Sequence (Local)

NOTICE
<p>If the utility power supply to the generator set's utility powered battery charger is interrupted, the battery can become discharged due to parasitic loads and the generator set may not start when needed. Whenever utility power is interrupted and the generator set is not in Standby mode for any reason (fuel preservation, etc.), start and run the generator set for 2 hours every 24 hour period when temperatures are <i>above</i> 50 °F (10 °C), or every 9 hour period when temperatures are <i>below</i> 50 °F (10 °C).</p>

The following steps will be executed when Manual Start is used at the local display:

1. If you do not want the ATS to transfer load to the generator set, open the generator set mounted circuit breaker when doing a manual start.
2. From the Main screen, select the **START** key.
3. A second screen appears notifying the operator that Standby will be disabled. Select the **START** key again to start the generator set.
4. After the generator set reaches rated voltage and frequency, the transfer switch transfers the building load to the generator set (unless the circuit breaker on the generator set is "off"). The building's electrical power is now provided by the generator set.

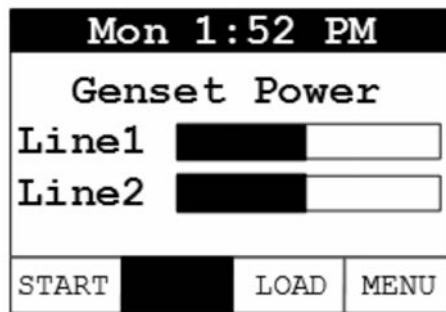

FIGURE 31. GENSET POWER

5.12 Checklist

Tick	Area
	General
	Generator set output is sufficient to handle maximum anticipated load.

Tick	Area
	<p>Proper clearance is provided around the entire generator set for service and ventilation:</p> <ul style="list-style-type: none"> • All parts of the generator set enclosure must be at least 60 inches (1524 mm) from any openings in walls of structures that may be occupied. Examples of wall openings include but are not limited to: operable windows, doors, dryer vents, fresh air intake for heaters, etc. • The engine side and alternator side of the generator set must be located as follows: <ul style="list-style-type: none"> ◦ One side (either engine or alternator) must be located not less than 18 inches (458 mm) from any structures having combustible walls. This space must be free of any obstructions for service access. ◦ The opposite side must be located not less than 60 inches (1524 mm) from any structures having combustible walls. A minimum of 18 inches (458 mm) of unobstructed space is required for service access. • The intake (cooling air inlet) side of the generator set must be located not less than 30 inches (762 mm) from any structures having combustible walls. This space must be free of obstructions to air flow and service access. • The generator set must be located such that exhaust gases are not able to accumulate in an occupied area. The air discharge side must always be unobstructed and spaced a minimum of 60 inches (1524 mm) from any structures having combustible walls. A minimum of 36 inches (915 mm) must be free of any combustible items, and unobstructed for service access. • The generator set must have enough room for installation, service, and maintenance. • The generator set must be located to ensure ventilation openings are not blocked. • Position the generator set so that cooling air is free to enter and leave the area. • Locate and position the generator set so that prevailing winds carry exhaust gases and potential fuel leaks away from the house or occupied area.
	The generator set is located in an area not subject to flooding.
	The generator set's service regulator is installed above the snow line.
	All operating personnel have read and are familiar with the generator set operator manual, all health and safety procedures, and all other documentation supplied with the generator set.
	All operators have been thoroughly briefed on preventive maintenance procedures.
	Proper clearance to openings in nearby structures is provided. Clearance around and over the generator set is provided for operation, service and maintenance.
Generator Set Mounting Pad	
	The earth on which the generator set mounting pad rests is strong enough and will not allow shifting or movement. Observe local codes on soil bearing capacity.

Tick	Area
	The generator set is properly supported and attached to an approved base.
	The supporting base is of non-combustible material and extends 2 inches (50.8 mm) all around the generator set.
	The generator set is located to comply with applicable codes and standards.
	Fuel System
	Verify that the generator set is configured to the fuel being used. (See the Fuel Selection and Fuel System Connection section.)
	Verify that the fuel line has proper volume capability.
	Verify that fuel pressure is correct: <ul style="list-style-type: none"> • Natural gas: 3.5 - 12 inch water column (0.9 - 3.0 kPa) • Propane: 6 - 12 inch water column (1.5 - 3.0 kPa) Maximum pressure for either fuel under any condition: 13 inch water column (3.2 kPa)
	Verify the fuel pressure at the generator set connection does not drop below the range listed above during startup and full load operation and does not exceed 13 inch water column (3.2 kPa).
	Verify that all fuel connections are tight.
	Verify there are no gas leaks in the fuel system.
	All electrical and fuel lines are properly separated.
	An approved flexible fuel line is properly installed between the generator set fuel inlet connection and the fuel supply line.
	Exhaust System
	All areas around the generator set are well ventilated, with no possibility of exhaust fumes entering building doors, windows, or intake fans.
	AC and DC Wiring
	Wire sizes, insulation, conduits and connection methods all meet applicable codes.
	All load, line and generator set connections are well made and correct.
	Flexible conduit is used between the generator set and the building or surrounding structure.
	A transfer switch has been installed properly to prevent connecting the generator set to the utility.
	Verify that 120 VAC power has been provided to the power battery charger and other AC accessories on the generator set.
	Generator Set Pre-Start
	The generator set engine is properly serviced with oil.
	All generator set and ATS covers and safety shields are installed correctly.

Tick	Area
	All fuel shutoff valves are operational and in the open position.
	The installation meets all applicable local, state, and federal codes.
	Control
	Verify that the clock, exerciser and correct fuel type are set.

5.13 Startup

1. Verify that the installation was completed correctly.
2. Read the operator manual. Perform the pre-start checks as instructed.
3. Connect the battery cables to the battery with the positive (+) cable first. Immediately cover the battery post and terminal with the red cover provided on the battery cable.
4. Although the generator set is shipped from the factory with the proper level of engine oil, check the oil level before it is started.
5. Start and test the system.
6. Operate the generator set following all the instructions and precautions in the operator manual.

NOTICE

Before leaving the site, if the generator set is ready to be placed in service, enable the Remote and Standby modes from the local display.

NOTICE

Contact your local Cummins service provider if you encounter a fault code.

6 Optional Remote Monitoring System (RMS) Description

6.1 Introduction

The Remote Monitoring System (RMS) feature allows for in-home or remote access to your generator set through a web page or smart phone app. Using the RMS, you can start or stop the generator set, adjust the exerciser date and time, determine if utility power is available, and view the last 20 events and/or faults on the generator set. This feature can also help to reduce troubleshooting time and the number of service calls if a generator service provider has access to the same information.

The internet/email interface can make the same fault, maintenance, and event notifications available to you and to your generator set service provider with an appropriate account setup.

RMS is optional. If you do not wish to use this service or do not have an Ethernet connection available, you are not required to set up an RMS account.

NOTICE

Technical support for setup and troubleshooting of the RMS is available through the selling Cummins Power Generation dealer/distributor.

However, due to variations in network equipment, network configurations, and internet and cellular service providers, the owner may be required to contact their Internet Service Provider, email service provider, or cellular service provider for technical support regarding internet connectivity, email notifications, and smart phone applications support.

Cummins does not provide technical support for the setup and troubleshooting of the owner's network, email, and cellular service.

NOTICE

The following Internet browsers are compatible with this option:

- **Microsoft Internet Explorer® (version 9 or greater)**
- **Apple Safari®**
- **Google Chrome™**
- **Mozilla Firefox® (version 3.6 or greater)**
- **Microsoft® Edge**

6.2 Optional Remote Monitoring System (RMS) Account Setup and Generator Set Control Connection

1. Prior to setting up the account, ensure that the generator set control is connected to the Internet via an Ethernet cable between the generator set control and the home's router.
2. Access the Cummins ConnectCloud website by navigating to ConnectCloud.Cummins.com.
3. Click on **Register** to create your account.
4. Add a generator set to your account, using the Serial Number and Customer Access Code from your generator set. The Serial Number and Customer Access Code can be found on the display in the **Menu/About** section.

NOTICE
Android and iPhone apps for the Cummins ConnectCloud are also available.

Appendix A. Fuel Line Selection

Table of Contents

Table 17. Required Information for Determining Fuel Line Size 82

Table 19. Equivalent Lengths of Pipe Fittings and Valves in Feet (Meters) 83

Table 21. Natural Gas Schedule 40 Metallic Pipe Sizing 85

Table 23. Natural Gas Semirigid Copper Tubing Sizing 87

Table 25. Propane Vapor Schedule 40 Metallic Pipe Sizing 89

Table 27. Propane Vapor Semirigid Copper Tubing Sizing 90

Table 29. Propane Schedule 40 Iron Pipe Sizing, Liquid Withdrawal (Maximum Capacity of Pipe in Cubic Feet of Gas per Hour)* 92

Figure 32. Minimum LPG Tank Size (50% Full) Required to Maintain 5 PSIG at Specific Withdrawal Rate and Minimum Expected Winter Temperature 94

A.0 Fuel System Pipe Sizing Introduction

Incorrect fuel line size may cause the generator set to not run or provide full power output.

Tables are included in this section to help calculate pipe sizing for natural gas and propane vapor withdrawal under specified conditions. Consult NFPA 54 or other applicable codes for other operating conditions or other fuel system installation requirements.

Refer to the *Engineering Application Manual T-030: Liquid Cooled Generator Sets* manual (A040S369) for more information.

To determine the optimal fuel line size, the following information is needed:

TABLE 17. REQUIRED INFORMATION FOR DETERMINING FUEL LINE SIZE

Category	Description
Fuel Flow Requirements for the Generator Set	Fuel flow requirements have a large impact on fuel line size.
Fuel Source (Natural Gas or Propane Vapor)	Fuel sources can affect fuel line size. Natural gas installations generally require a higher fuel flow rate compared to propane vapor installations, since propane has a higher energy content.
Fuel Line Length (Including Fittings)	As fuel line lengths increase, they may require larger diameter fuel lines. Be sure to consider the equivalent length of all of the fittings (elbows, tees, valves) in the installation in addition to the straight pipe length.
Fuel Line Type (e.g., Copper Tubing or Iron Pipe)	Most fuel line types are iron pipe or copper tubing. Be sure to use the sizing chart for the fuel line type when sizing the fuel line.

NOTICE

NFPA 54 has selection tables for other approved fuel lines. Verify with the authorities having jurisdiction the allowed fuel line type for the generator set installation.

A.1 Gas Pipe Sizing

NOTICE

The following tables in this section are reprinted with permission from NFPA 54-2015, *National Fuel Gas Code*, Copyright © 2014, National Fire Protection Association.

- Natural Gas Schedule 40 Metallic Pipe Sizing
- Natural Gas Semirigid Copper Tubing Sizing
- Propane Vapor Schedule 40 Iron Pipe Sizing
- Propane Vapor Semirigid Copper Tubing Sizing
- Propane Schedule 40 Iron Pipe Sizing, Liquid Withdrawal (Maximum Capacity of Pipe in Cubic Feet of Gas per Hour)

This reprinted material is not the complete and official position of the NFPA on the referenced subject, which is represented only by the standard in its entirety.

Sizing of gas piping for proper fuel delivery, both flow and pressure, can become quite complex. A simplified method is to convert all fittings, valves, etc. to equivalent lengths of pipe in the diameter(s) being considered. The total equivalent length can then be related to flow capacity. Equivalent lengths of pipe fittings and valves can be found in the table below.

TABLE 19. EQUIVALENT LENGTHS OF PIPE FITTINGS AND VALVES IN FEET (METERS)

TYPE OF FITTING	NOMINAL INCH (MILLIMETER) PIPE SIZE								
	1/2 (15)	3/4 (20)	1 (25)	1-1/4 (32)	1-1/2 (40)	2 (50)	2-1/2 (65)	3 (80)	4 (100)
90° Std. Elbow or Tee Reduced ½.	1.6 (0.5)	2.0 (0.6)	2.6 (0.8)	3.3 (1.0)	4.0 (1.2)	5.0 (1.5)	6.0 (1.8)	7.5 (2.3)	10.0 (3.1)
90° Long Radius Elbow or Straight Run Tee	1.0 (0.3)	1.4 (0.4)	1.7 (0.5)	2.3 (0.7)	2.6 (0.8)	3.3 (1.0)	4.1 (1.3)	5.0 (1.5)	6.7 (2.0)
45° Elbow	0.8 (0.2)	0.9 (0.3)	1.3 (0.4)	1.7 (0.5)	2.1 (0.6)	2.6 (0.8)	3.2 (1.0)	4.0 (1.2)	5.2 (1.6)
180° Std. Bend	2.5 (0.8)	3.2 (1.0)	4.1 (1.2)	5.6 (1.7)	6.3 (1.9)	8.2 (2.5)	10.0 (3.1)	12.0 (3.7)	17.0 (5.2)
TEE, Side Inlet or Outlet	3.0 (0.9)	4.0 (1.2)	5.0 (1.5)	7.0 (2.1)	8.0 (2.4)	10.0 (3.0)	12.0 (3.7)	15.0 (4.6)	21.0 (6.4)

Foot Valve and Strainer	3.7 (1.1)	4.9 (1.5)	7.5 (2.3)	8.9 (2.7)	11.0 (3.4)	15.0 (4.6)	18.0 (5.5)	22.0 (6.7)	29.0 (8.8)
Swing Check Valve, Fully Open	6.0 (1.8)	8.0 (2.4)	10.0 (3.0)	14.0 (4.3)	16.0 (4.9)	20.0 (6.1)	25.0 (7.6)	30.0 (9.1)	40.0 (12.2)
Globe Valve, Fully Open	18.0 (5.5)	22.0 (6.7)	29.0 (8.8)	38.0 (11.6)	43.0 (13.1)	55.0 (16.8)	69.0 (21.0)	84.0 (25.6)	120.0 (36.6)
Angle Valve, Fully Open	7.0 (2.1)	9.0 (2.7)	12.0 (3.7)	15.0 (4.6)	18.0 (5.5)	24.0 (7.3)	29.0 (8.8)	35.0 (10.7)	47.0 (14.3)
Gate Valve, Fully Open	0.7 (0.2)	0.9 (0.3)	1.0 (0.3)	1.5 (0.5)	1.8 (0.5)	2.3 (0.7)	2.8 (0.9)	3.2 (1.0)	4.5 (1.4)

The remaining tables in this section show maximum gas capacity for equivalent lengths of various pipe sizes.

Here are some basic but very important steps that all installers must follow to make sure that fuel lines are sized correctly:

1. Verify adequate fuel flow, quality, and pressure available from the natural gas utility connection or the propane system.
2. Obtain the maximum fuel consumption requirements at full load for the specific generator set from the Model Specifications section and for all gas appliances attached to the pipe system.
3. Make a list of all the fittings and valves in the proposed system used in this generator set installation.
4. Determine the equivalent length of all fuel line fittings (elbows, tees, and valves). (See the NFPA Pipe Fittings table in this appendix to determine the equivalent lengths for all fuel line fittings.)
5. Add the equivalent length of the fuel line fittings to the lengths of straight pipe to determine the total equivalent length of the system.
6. Choose the applicable table in this appendix based on the fuel type (natural gas, propane vapor or liquid propane) and fuel line material.
7. Determine the fuel line size at full load:
 - a. Locate the equivalent length of pipe (or next larger equivalent length) in the left hand column.
 - b. Move across the row to where the maximum flow capacity number is as large or larger than the maximum fuel consumption.
 - c. Move to the top of that column to where the minimum nominal pipe size or tubing size required **for the system as designed** is shown.

TABLE 21. NATURAL GAS SCHEDULE 40 METALLIC PIPE SIZING

Gas:	Natural													
Inlet Pressure:	Less than 2 psi													
Pressure Drop:	0.5 in. w.c.													
Specific Gravity:	0.60													
	Pipe Size (in.)													
Nominal :	1/2	3/4	1	1 1/4	1 1/2	2	2 1/2	3	4	5	6	8	10	12
Actual ID:	0.622	0.824	1.049	1.380	1.610	2.067	2.469	3.068	4.026	5.047	6.065	7.981	10.020	11.938
Length (ft)	Capacity in Cubic Feet of Gas per Hour													
10	172	360	678	1,390	2,090	4,020	6,400	11,300	23,100	41,800	67,600	139,000	252,000	399,000
20	118	247	466	957	1,430	2,760	4,400	7,780	15,900	28,700	46,500	95,500	173,000	275,000
30	95	199	374	768	1,150	2,220	3,530	6,250	12,700	23,000	37,300	76,700	139,000	220,000
40	81	170	320	657	985	1,900	3,020	5,350	10,900	19,700	31,900	65,600	119,000	189,000
50	72	151	284	583	873	1,680	2,680	4,740	9,660	17,500	28,300	58,200	106,000	167,000
60	65	137	257	528	791	1,520	2,430	4,290	8,760	15,800	25,600	52,700	95,700	152,000
70	60	126	237	486	728	1,400	2,230	3,950	8,050	14,600	23,600	48,500	88,100	139,000
80	56	117	220	452	677	1,300	2,080	3,670	7,490	13,600	22,000	45,100	81,900	130,000
90	52	110	207	424	635	1,220	1,950	3,450	7,030	12,700	20,600	42,300	76,900	122,000
100	50	104	195	400	600	1,160	1,840	3,260	6,640	12,000	19,500	40,000	72,600	115,000
125	44	92	173	355	532	1,020	1,630	2,890	5,890	10,600	17,200	35,400	64,300	102,000
150	40	83	157	322	482	928	1,480	2,610	5,330	9,650	15,600	32,100	58,300	92,300
175	37	77	144	296	443	854	1,360	2,410	4,910	8,880	14,400	29,500	53,600	84,900

200	34	71	134	275	412	794	1,270	2,240	4,560	8,260	13,400	27,500	49,900	79,000
250	30	63	119	244	366	704	1,120	1,980	4,050	7,320	11,900	24,300	44,200	70,000
300	27	57	108	221	331	638	1,020	1,800	3,670	6,630	10,700	22,100	40,100	63,400
350	25	53	99	203	305	587	935	1,650	3,370	6,100	9,880	20,300	36,900	58,400
400	23	49	92	189	283	546	870	1,540	3,140	5,680	9,190	18,900	34,300	54,300
450	22	46	86	177	266	512	816	1,440	2,940	5,330	8,620	17,700	32,200	50,900
500	21	43	82	168	251	484	771	1,360	2,780	5,030	8,150	16,700	30,400	48,100
550	20	41	78	159	239	459	732	1,290	2,640	4,780	7,740	15,900	28,900	45,700
600	19	39	74	152	228	438	699	1,240	2,520	4,560	7,380	15,200	27,500	43,600
650	18	38	71	145	218	420	669	1,180	2,410	4,360	7,070	14,500	26,400	41,800
700	17	36	68	140	209	403	643	1,140	2,320	4,190	6,790	14,000	25,300	40,100
750	17	35	66	135	202	389	619	1,090	2,230	4,040	6,540	13,400	24,400	38,600
800	16	34	63	130	195	375	598	1,060	2,160	3,900	6,320	13,000	23,600	37,300
850	16	33	61	126	189	363	579	1,020	2,090	3,780	6,110	12,600	22,800	36,100
900	15	32	59	122	183	352	561	992	2,020	3,660	5,930	12,200	22,100	35,000
950	15	31	58	118	178	342	545	963	1,960	3,550	5,760	11,800	21,500	34,000
1,000	14	30	56	115	173	333	530	937	1,910	3,460	5,600	11,500	20,900	33,100
1,100	14	28	53	109	164	316	503	890	1,810	3,280	5,320	10,900	19,800	31,400
1,200	13	27	51	104	156	301	480	849	1,730	3,130	5,070	10,400	18,900	30,000

1,30 0	12	26	49	100	150	289	460	813	1,66 0	3,00 0	4,86 0	9,98 0	18,1 00	28,7 00
1,40 0	12	25	47	96	144	277	442	781	1,59 0	2,88 0	4,67 0	9,59 0	17,4 00	27,6 00
1,50 0	11	24	45	93	139	267	426	752	1,53 0	2,78 0	4,50 0	9,24 0	16,8 00	26,6 00
1,60 0	11	23	44	89	134	258	411	727	1,48 0	2,68 0	4,34 0	8,92 0	16,2 00	25,6 00
1,70 0	11	22	42	86	130	250	398	703	1,43 0	2,59 0	4,20 0	8,63 0	15,7 00	24,8 00
1,80 0	10	22	41	84	126	242	386	682	1,39 0	2,52 0	4,07 0	8,37 0	15,2 00	24,1 00
1,90 0	10	21	40	81	122	235	375	662	1,35 0	2,44 0	3,96 0	8,13 0	14,8 00	23,4 00
2,00 0	NA	20	39	79	119	229	364	644	1,31 0	2,38 0	3,85 0	7,91 0	14,4 00	22,7 00

NA: Applies to a flow of less than 10 cfh.

Note: All table entries are rounded to 3 significant digits.

TABLE 23. NATURAL GAS SEMIRIGID COPPER TUBING SIZING

Gas:	Natural								
Inlet Pressure:	Less than 2 psi								
Pressure Drop:	0.5 in. w.c.								
Specific Gravity:	0.60								
	Tube Size (in.)								
Nominal K & L:	1/4	3/8	1/2	5/8	3/4	1	1 1/4	1 1/2	2
Nominal ACR:	3/8	1/2	5/8	3/4	7/8	1 1/8	1 3/8	—	—
Outside:	0.375	0.500	0.625	0.750	0.875	1.125	1.375	1.625	2.125
Inside:*	0.305	0.402	0.527	0.652	0.745	0.995	1.245	1.481	1.959
Length (ft.)	Capacity in Cubic Feet of Gas per Hour								
10	27	55	111	195	276	590	1,060	1,680	3,490
20	18	38	77	134	190	406	730	1,150	2,400
30	15	30	61	107	152	326	586	925	1,930

40	13	26	53	92	131	279	502	791	1,650
50	11	23	47	82	116	247	445	701	1,460
60	10	21	42	74	105	224	403	635	1,320
70	NA	19	39	68	96	206	371	585	1,220
80	NA	18	36	63	90	192	345	544	1,130
90	NA	17	34	59	84	180	324	510	1,060
100	NA	16	32	56	79	170	306	482	1,000
125	NA	14	28	50	70	151	271	427	890
150	NA	13	26	45	64	136	245	387	806
175	NA	12	24	41	59	125	226	356	742
200	NA	11	22	39	55	117	210	331	690
250	NA	NA	20	34	48	103	186	294	612
300	NA	NA	18	31	44	94	169	266	554
350	NA	NA	16	28	40	86	155	245	510
400	NA	NA	15	26	38	80	144	228	474
450	NA	NA	14	25	35	75	135	214	445
500	NA	NA	13	23	33	71	128	202	420
550	NA	NA	13	22	32	68	122	192	399
600	NA	NA	12	21	30	64	116	183	381
650	NA	NA	12	20	29	62	111	175	365
700	NA	NA	11	20	28	59	107	168	350
750	NA	NA	11	19	27	57	103	162	338
800	NA	NA	10	18	26	55	99	156	326
850	NA	NA	10	18	25	53	96	151	315
900	NA	NA	NA	17	24	52	93	147	306
950	NA	NA	NA	17	24	50	90	143	297
1,000	NA	NA	NA	16	23	49	88	139	289
1,100	NA	NA	NA	15	22	46	84	132	274
1,200	NA	NA	NA	15	21	44	80	126	262
1,300	NA	NA	NA	14	20	42	76	120	251
1,400	NA	NA	NA	13	19	41	73	116	241
1,500	NA	NA	NA	13	18	39	71	111	232

1,600	NA	NA	NA	13	18	38	68	108	224
1,700	NA	NA	NA	12	17	37	66	104	217
1,800	NA	NA	NA	12	17	36	64	101	210
1,900	NA	NA	NA	11	16	35	62	98	204
2,000	NA	NA	NA	11	16	34	60	95	199

NA: A flow of less than 10 cfh.
 Note: All table entries are rounded to 3 significant digits.
 *Table capacities are based on Type K copper tubing inside diameter (shown), which has the smallest inside diameter of the copper tubing products.

TABLE 25. PROPANE VAPOR SCHEDULE 40 METALLIC PIPE SIZING

Gas:		Undiluted Propane							
Inlet Pressure:		11.0 in. w.c.							
Pressure Drop:		0.5 in. w.c.							
Specific Gravity:		1.50							
INTENDED USE: Pipe Sizing Between Single- or Second-Stage (Low-Pressure) Regulator and Appliance									
Pipe Size (in.)									
Nominal Inside:	1/2	3/4	1	1 1/4	1 1/2	2	2 1/2	3	4
Actual:	0.622	0.824	1.049	1.380	1.610	2.067	2.469	3.068	4.026
Length (ft.)	Capacity in Thousands of BTU per Hour								
10	291	608	1,150	2,350	3,520	6,790	10,800	19,100	39,000
20	200	418	787	1,620	2,420	4,660	7,430	13,100	26,800
30	160	336	632	1,300	1,940	3,750	5,970	10,600	21,500
40	137	287	541	1,110	1,660	3,210	5,110	9,030	18,400
50	122	255	480	985	1,480	2,840	4,530	8,000	16,300
60	110	231	434	892	1,340	2,570	4,100	7,250	14,800
80	101	212	400	821	1,230	2,370	3,770	6,670	13,600
100	94	197	372	763	1,140	2,200	3,510	6,210	12,700
125	89	185	349	716	1,070	2,070	3,290	5,820	11,900
150	84	175	330	677	1,010	1,950	3,110	5,500	11,200
175	74	155	292	600	899	1,730	2,760	4,880	9,950

200	67	140	265	543	814	1,570	2,500	4,420	9,010
250	62	129	243	500	749	1,440	2,300	4,060	8,290
300	58	120	227	465	697	1,340	2,140	3,780	7,710
350	51	107	201	412	618	1,190	1,900	3,350	6,840
400	46	97	182	373	560	1,080	1,720	3,040	6,190
450	42	89	167	344	515	991	1,580	2,790	5,700
500	40	83	156	320	479	922	1,470	2,600	5,300
550	37	78	146	300	449	865	1,380	2,440	4,970
600	35	73	138	283	424	817	1,300	2,300	4,700
650	33	70	131	269	403	776	1,240	2,190	4,460
700	32	66	125	257	385	741	1,180	2,090	4,260
750	30	64	120	246	368	709	1,130	2,000	4,080
800	29	61	115	236	354	681	1,090	1,920	3,920
850	28	59	111	227	341	656	1,050	1,850	3,770
900	27	57	107	220	329	634	1,010	1,790	3,640
950	26	55	104	213	319	613	978	1,730	3,530
1,000	25	53	100	206	309	595	948	1,680	3,420
1,100	25	52	97	200	300	578	921	1,630	3,320
1,200	24	50	95	195	292	562	895	1,580	3,230
1,300	23	48	90	185	277	534	850	1,500	3,070
1,400	22	46	86	176	264	509	811	1,430	2,930
1,500	21	44	82	169	253	487	777	1,370	2,800
1,600	20	42	79	162	243	468	746	1,320	2,690
1,700	19	40	76	156	234	451	719	1,270	2,590
1,800	19	39	74	151	226	436	694	1,230	2,500
1,900	18	38	71	146	219	422	672	1,190	2,420
2,000	18	37	69	142	212	409	652	1,150	2,350

Note: All table entries are rounded to 3 significant digits.

TABLE 27. PROPANE VAPOR SEMIRIGID COPPER TUBING SIZING

Gas:	Undiluted Propane
Inlet Pressure:	11.0 in. w.c.

Pressure Drop:		0.5 in. w.c.							
Specific Gravity:		1.50							
INTENDED USE: Tube Sizing Between Single- or Second-Stage (Low-Pressure) Regulator and Appliance									
	Tube Size (in.)								
Nominal K & L:	1/4	3/8	1/2	5/8	3/4	1	1 1/4	1 1/2	2
Nominal ACR:	3/8	1/2	5/8	3/4	7/8	1 1/8	1 3/8	—	—
Outside:	0.375	0.500	0.625	0.750	0.875	1.125	1.375	1.625	2.125
Inside:*	0.305	0.402	0.527	0.652	0.745	0.995	1.245	1.481	1.959
Length (ft.)	Capacity in Thousands of BTU per Hour								
10	45	93	188	329	467	997	1,800	2,830	5,890
20	31	64	129	226	321	685	1,230	1,950	4,050
30	25	51	104	182	258	550	991	1,560	3,250
40	21	44	89	155	220	471	848	1,340	2,780
50	19	39	79	138	195	417	752	1,180	2,470
60	17	35	71	125	177	378	681	1,070	2,240
70	16	32	66	115	163	348	626	988	2,060
80	15	30	61	107	152	324	583	919	1,910
90	14	28	57	100	142	304	547	862	1,800
100	13	27	54	95	134	287	517	814	1,700
125	11	24	48	84	119	254	458	722	1,500
150	10	21	44	76	108	230	415	654	1,360
175	NA	20	40	70	99	212	382	602	1,250
200	NA	18	37	65	92	197	355	560	1,170
250	NA	16	33	58	82	175	315	496	1,030
300	NA	15	30	52	74	158	285	449	936
350	NA	14	28	48	68	146	262	414	861
400	NA	13	26	45	63	136	244	385	801
450	NA	12	24	42	60	127	229	361	752
500	NA	11	23	40	56	120	216	341	710
550	NA	11	22	38	53	114	205	324	674

600	NA	10	21	36	51	109	196	309	643
650	NA	NA	20	34	49	104	188	296	616
700	NA	NA	19	33	47	100	180	284	592
750	NA	NA	18	32	45	96	174	274	570
800	NA	NA	18	31	44	93	168	264	551
850	NA	NA	17	30	42	90	162	256	533
900	NA	NA	17	29	41	87	157	248	517
950	NA	NA	16	28	40	85	153	241	502
1,000	NA	NA	16	27	39	83	149	234	488
1,100	NA	NA	15	26	37	78	141	223	464
1,200	NA	NA	14	25	35	75	135	212	442
1,300	NA	NA	14	24	34	72	129	203	423
1,400	NA	NA	13	23	32	69	124	195	407
1,500	NA	NA	13	22	31	66	119	188	392
1,600	NA	NA	12	21	30	64	115	182	378
1,700	NA	NA	12	20	29	62	112	176	366
1,800	NA	NA	11	20	28	60	108	170	355
1,900	NA	NA	11	19	27	58	105	166	345
2,000	NA	NA	11	19	27	57	102	161	335

NA: A flow of less than 10,000 BTU/hr.
Note: All table entries are rounded to 3 significant digits.
*Table capacities are based on Type K copper tubing inside diameter (shown), which has the smallest inside diameter of the copper tubing products.

**TABLE 29. PROPANE SCHEDULE 40 IRON PIPE SIZING, LIQUID WITHDRAWAL
(MAXIMUM CAPACITY OF PIPE IN CUBIC FEET OF GAS PER HOUR)***

Equivalent Length of Pipe (ft.)	Schedule 40 Iron Pipe Size (in.): Nominal (Inside Diameter)								
	1/2 (0.622)	3/4 (0.824)	1 (1.049)	1 1/4 (1.38)	1 1/2 (1.61)	2 (2.067)	3 (3.068)	3 1/2 (3.548)	4 (4.026)
30	733	1,532	2,885	5,924	8,876	17,094	48,164	70,519	98,238
40	627	1,311	2,469	5,070	7,597	14,630	41,222	60,355	84,079

Equivalent Length of Pipe (ft.)	Schedule 40 Iron Pipe Size (in.): Nominal (Inside Diameter)								
	1/2 (0.622)	3/4 (0.824)	1 (1.049)	1 1/4 (1.38)	1 1/2 (1.61)	2 (2.067)	3 (3.068)	3 1/2 (3.548)	4 (4.026)
50	556	1,162	2,189	4,494	6,733	12,966	36,534	53,492	74,518
60	504	1,053	1,983	4,072	6,100	11,748	33,103	48,467	67,519
70	463	969	1,824	3,746	5,612	10,808	30,454	44,589	62,116
80	431	901	1,697	3,484	5,221	10,055	28,331	41,482	57,787
90	404	845	1,593	3,269	4,899	9,434	26,583	38,921	54,220
100	382	798	1,504	3,088	4,627	8,912	25,110	36,764	51,216
150	307	641	1,208	2,480	3,716	7,156	20,164	29,523	41,128
200	262	549	1,034	2,122	3,180	6,125	17,258	25,268	35,200
250	233	486	916	1,881	2,819	5,428	15,295	22,395	31,198
300	211	441	830	1,705	2,554	4,919	13,859	20,291	28,267
350	194	405	764	1,568	2,349	4,525	12,750	18,667	26,006
400	180	377	711	1,459	2,186	4,209	11,861	17,366	24,193
450	169	354	667	1,369	2,051	3,950	11,129	16,295	22,700
500	160	334	630	1,293	1,937	3,731	10,512	15,391	21,442
600	145	303	571	1,172	1,755	3,380	9,525	13,946	19,428
700	133	279	525	1,078	1,615	3,110	8,763	12,830	17,873
800	124	259	488	1,003	1,502	2,893	8,152	11,936	16,628

Equivalent Length of Pipe (ft.)	Schedule 40 Iron Pipe Size (in.): Nominal (Inside Diameter)								
	1/2 (0.622)	3/4 (0.824)	1 (1.049)	1 1/4 (1.38)	1 1/2 (1.61)	2 (2.067)	3 (3.068)	3 1/2 (3.548)	4 (4.026)
900	116	243	458	941	1,409	2,715	7,649	11,199	15,601
1000	110	230	433	889	1,331	2,564	7,225	10,579	14,737
1500	88	184	348	713	1,069	2,059	5,802	8,495	11,834
2000	76	158	297	611	915	1,762	4,966	7,271	10,128

*Pipe size recommendations are based on schedule 40 black iron pipe.

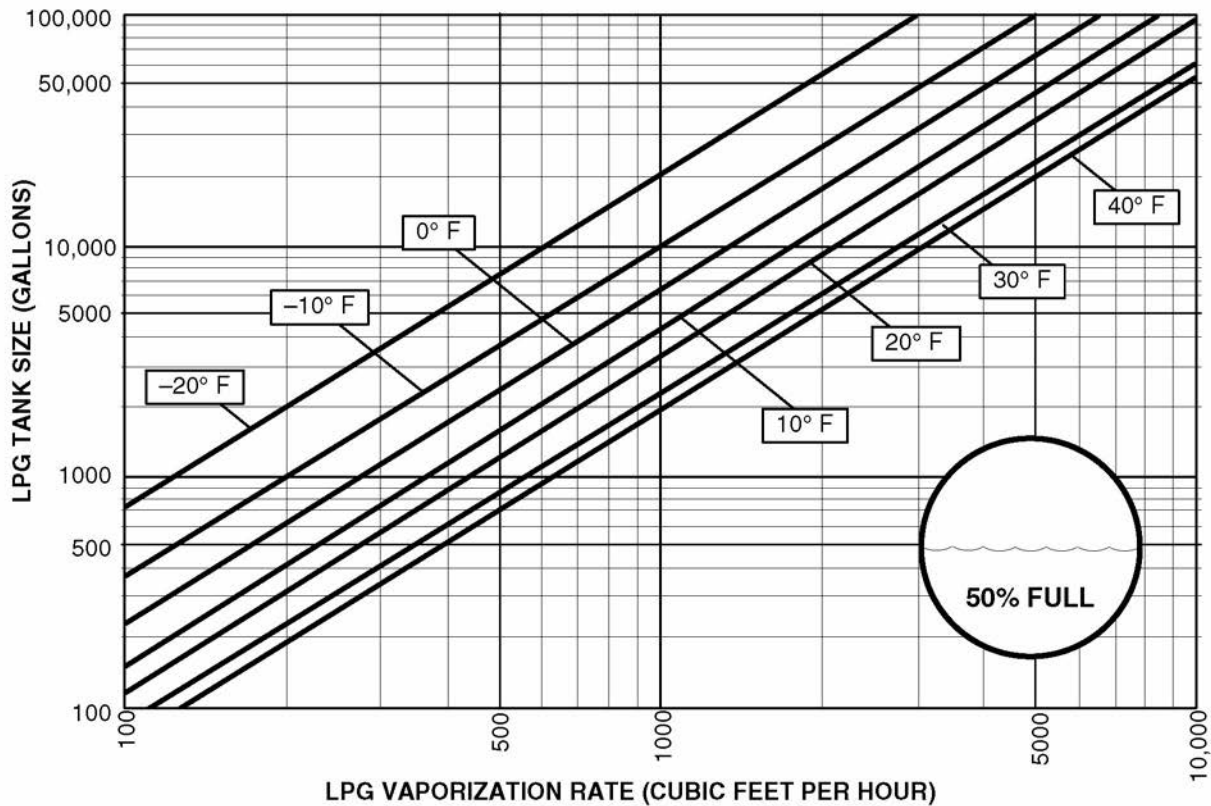

FIGURE 32. MINIMUM LPG TANK SIZE (50% FULL) REQUIRED TO MAINTAIN 5 PSIG AT SPECIFIC WITHDRAWAL RATE AND MINIMUM EXPECTED WINTER TEMPERATURE

Appendix B. Outline and System Drawings

Table of Contents

Figure 33. Generator Set Outline (Sheet 1 of 4) 97
Figure 34. Generator Set Outline (Sheet 2 of 4) 98
Figure 35. Generator Set Outline (Sheet 3 of 4) 99
Figure 36. Generator Set Outline (Sheet 4 of 4) 100

The drawings included in this section are representative. For current complete information, refer to the drawing package that was shipped with the unit.

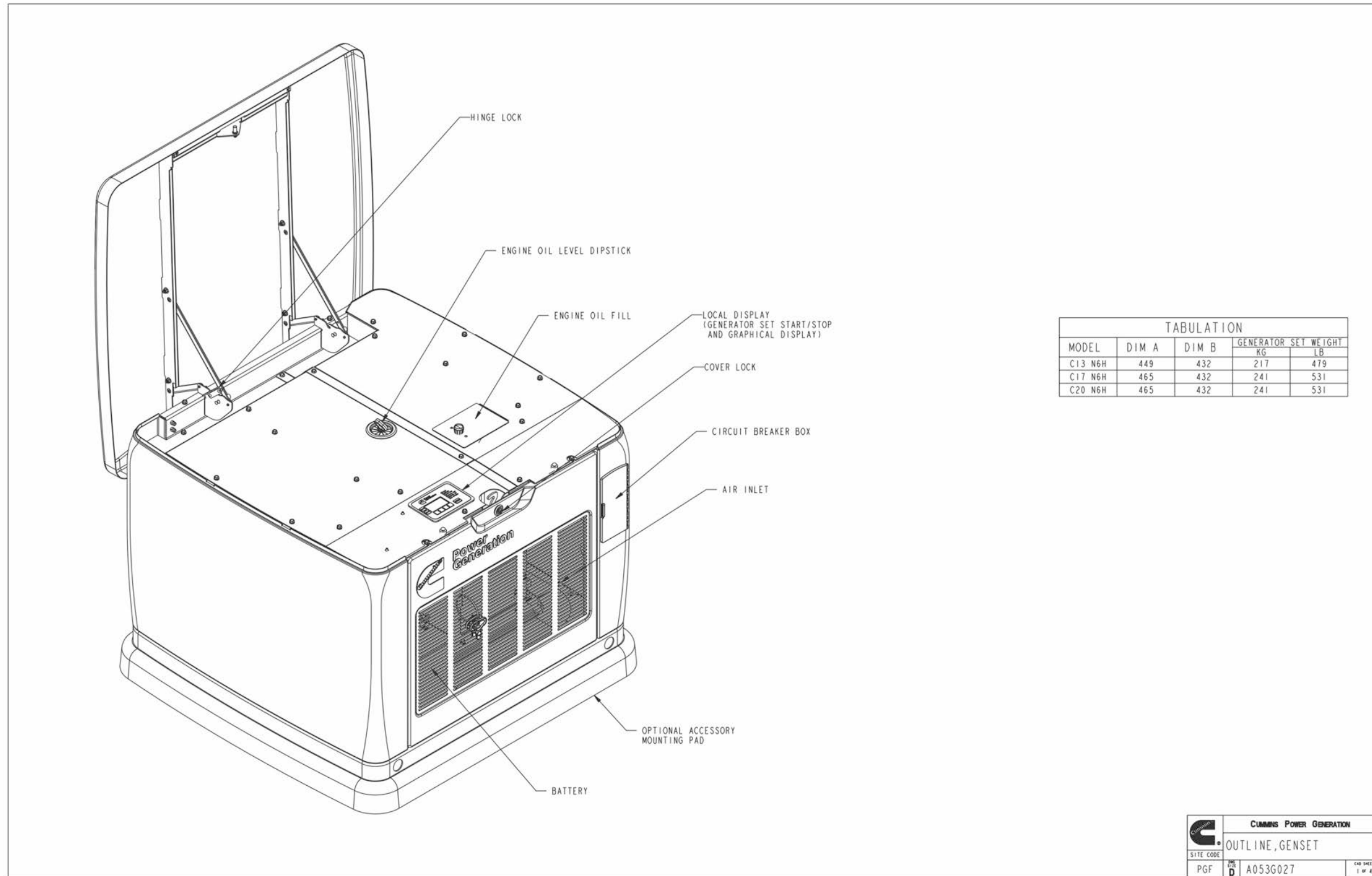

TABULATION

MODEL	DIM A	DIM B	GENERATOR SET WEIGHT	
			KG	LB
C13 N6H	449	432	217	479
C17 N6H	465	432	241	531
C20 N6H	465	432	241	531

	CUMMINS POWER GENERATION		
	OUTLINE, GENSET		
SITE CODE	REV	Dwg No.	SHEET
PGF	D	A053G027	1 of 4

FIGURE 33. GENERATOR SET OUTLINE (SHEET 1 OF 4)

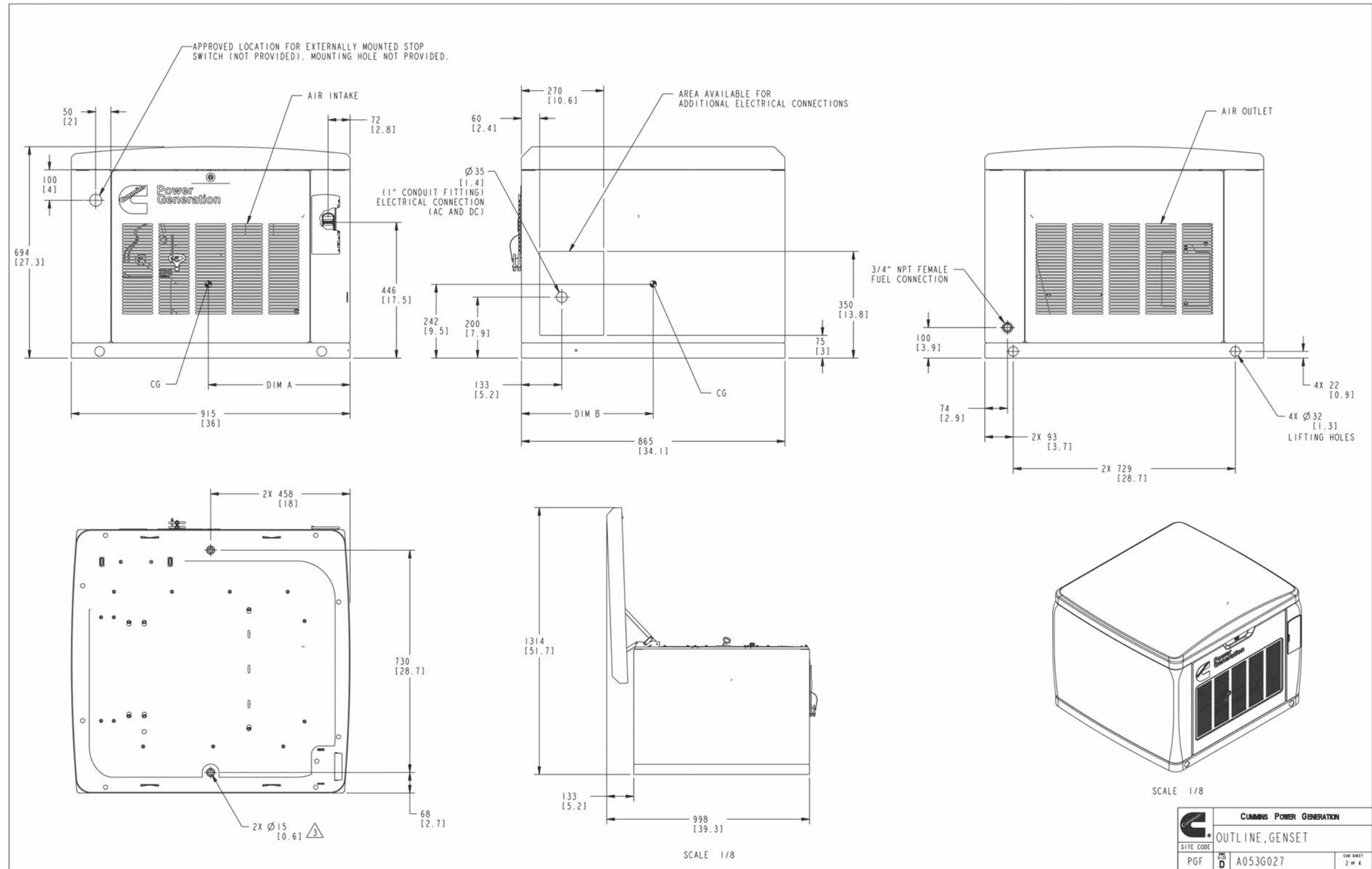

FIGURE 34. GENERATOR SET OUTLINE (SHEET 2 OF 4)

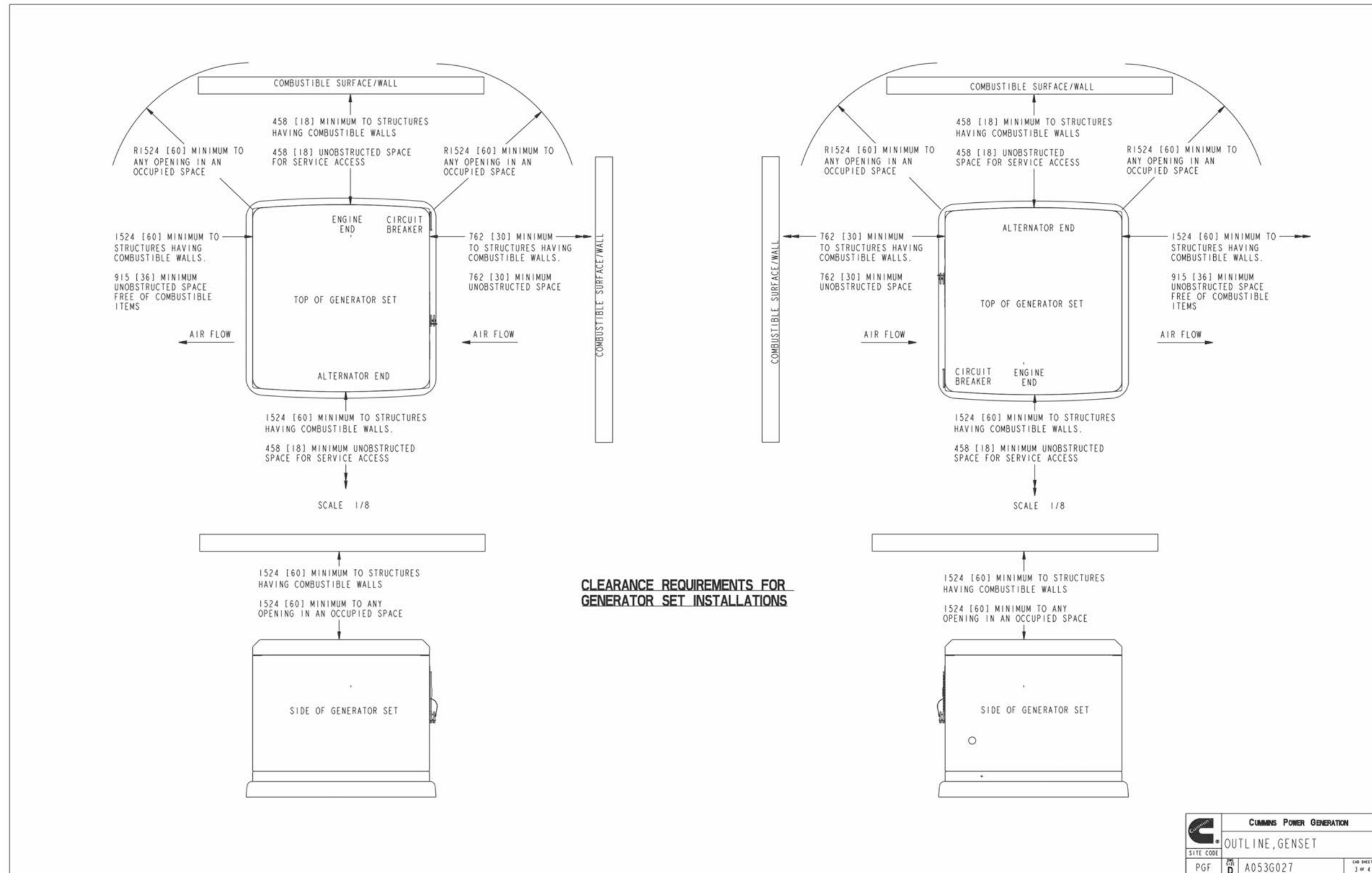

FIGURE 35. GENERATOR SET OUTLINE (SHEET 3 OF 4)

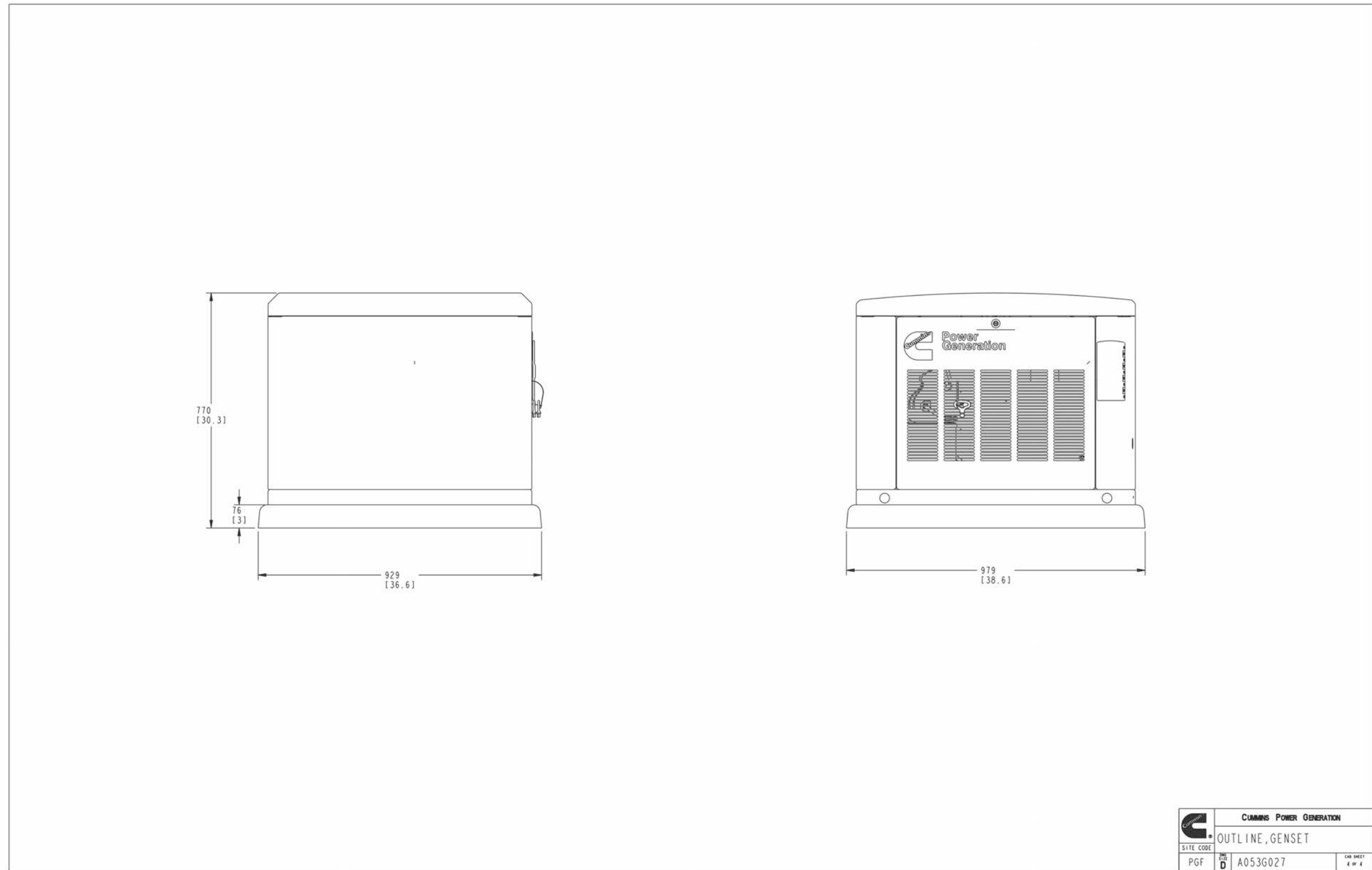

FIGURE 36. GENERATOR SET OUTLINE (SHEET 4 OF 4)

Appendix C. Wiring Diagrams

Table of Contents

Figure 37. Wiring Diagram (Sheet 1 of 4)	103
Figure 38. Wiring Diagram (Sheet 2 of 4)	104
Figure 39. Wiring Diagram (Sheet 3 of 4)	105
Figure 40. Wiring Diagram (Sheet 4 of 4)	106
Figure 41. Harness, Generator Set Electrical (Sheet 1 of 3)	107
Figure 42. Harness, Generator Set Electrical (Sheet 2 of 3)	108
Figure 43. Harness, Generator Set Electrical (Sheet 3 of 3)	109

C.0 Wiring Diagrams

The drawings included in this section are representative. For current complete information, refer to the drawing package that was shipped with the unit.

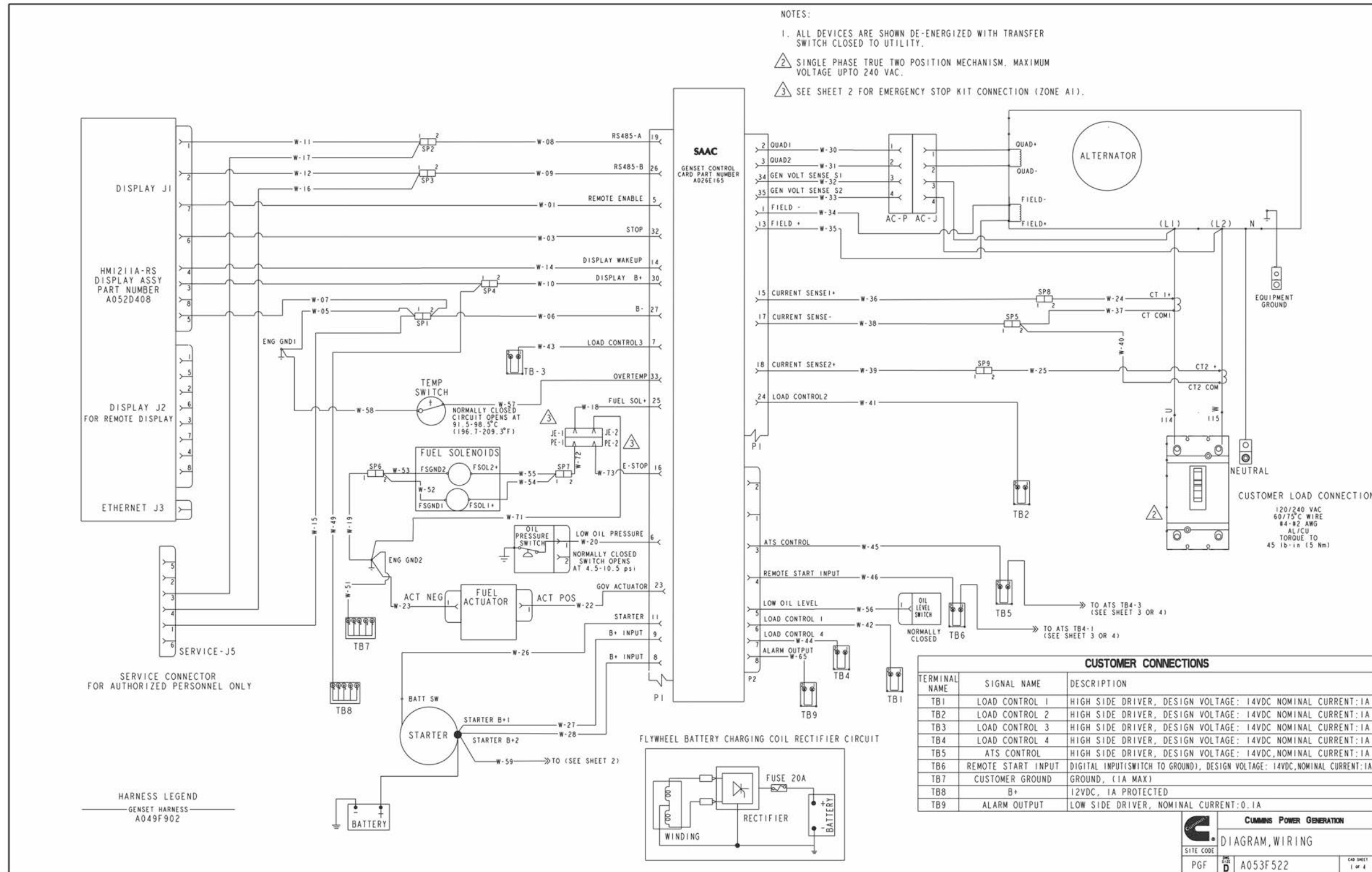

FIGURE 37. WIRING DIAGRAM (SHEET 1 OF 4)

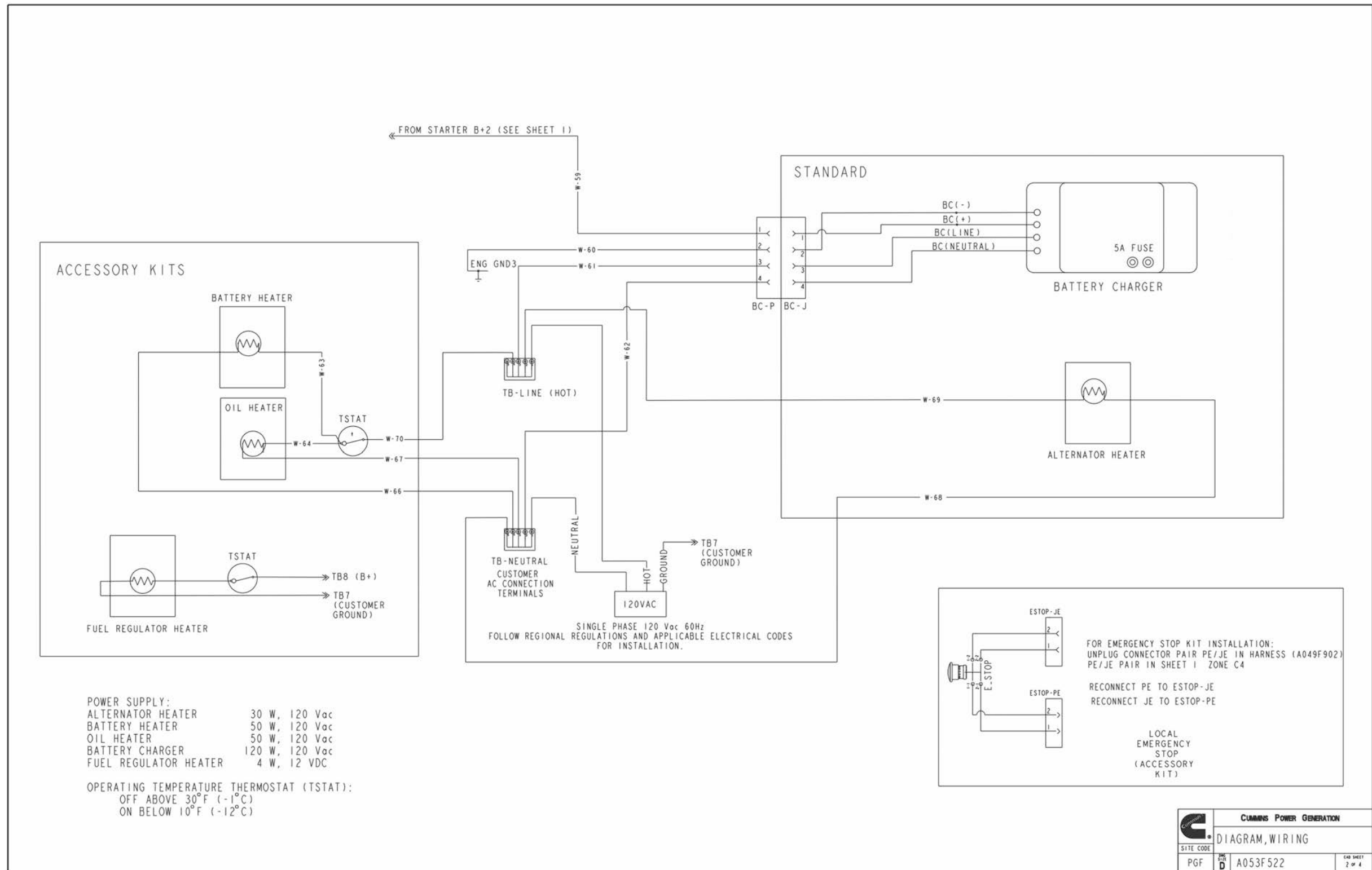

FIGURE 38. WIRING DIAGRAM (SHEET 2 OF 4)

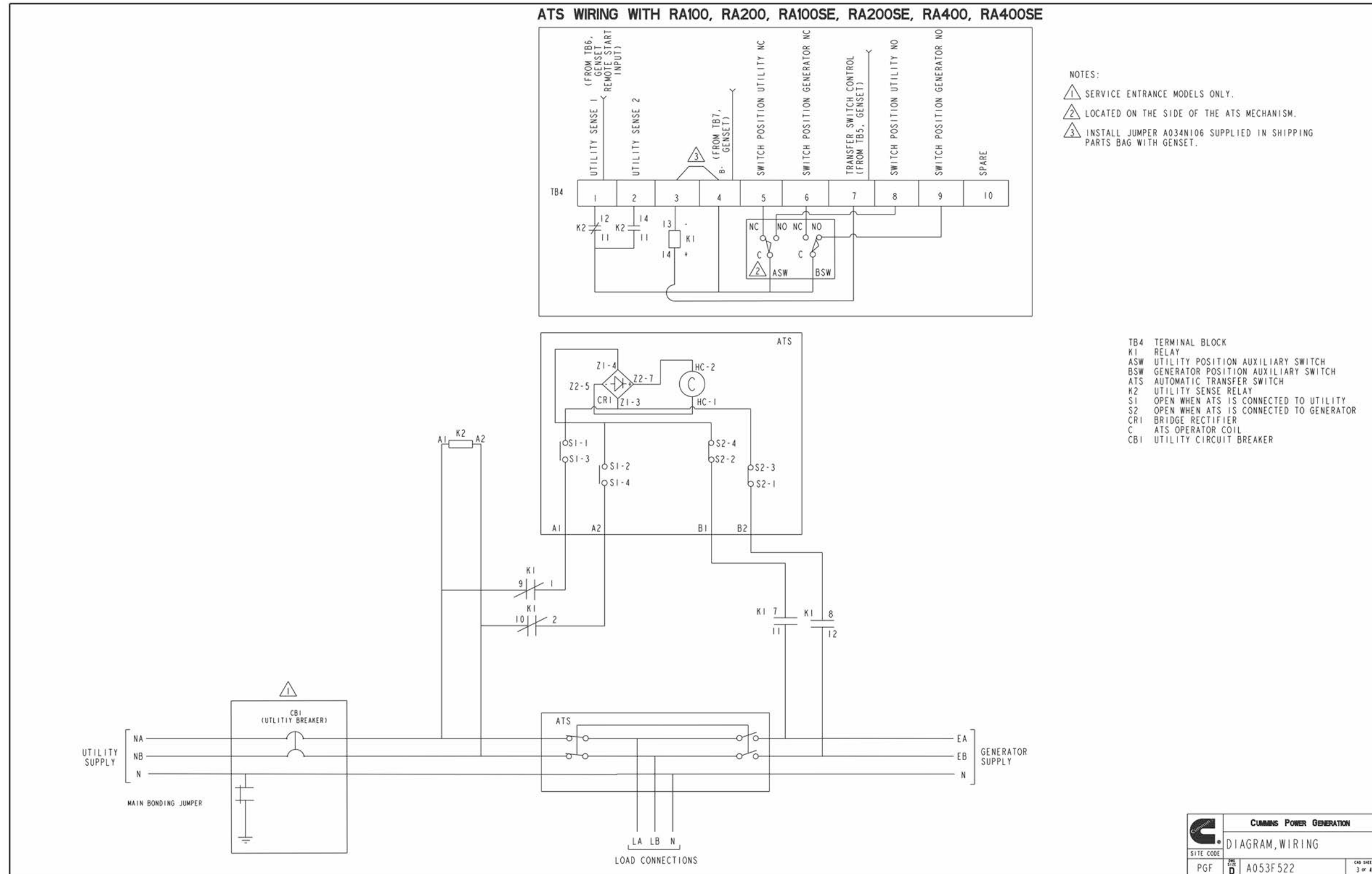

FIGURE 39. WIRING DIAGRAM (SHEET 3 OF 4)

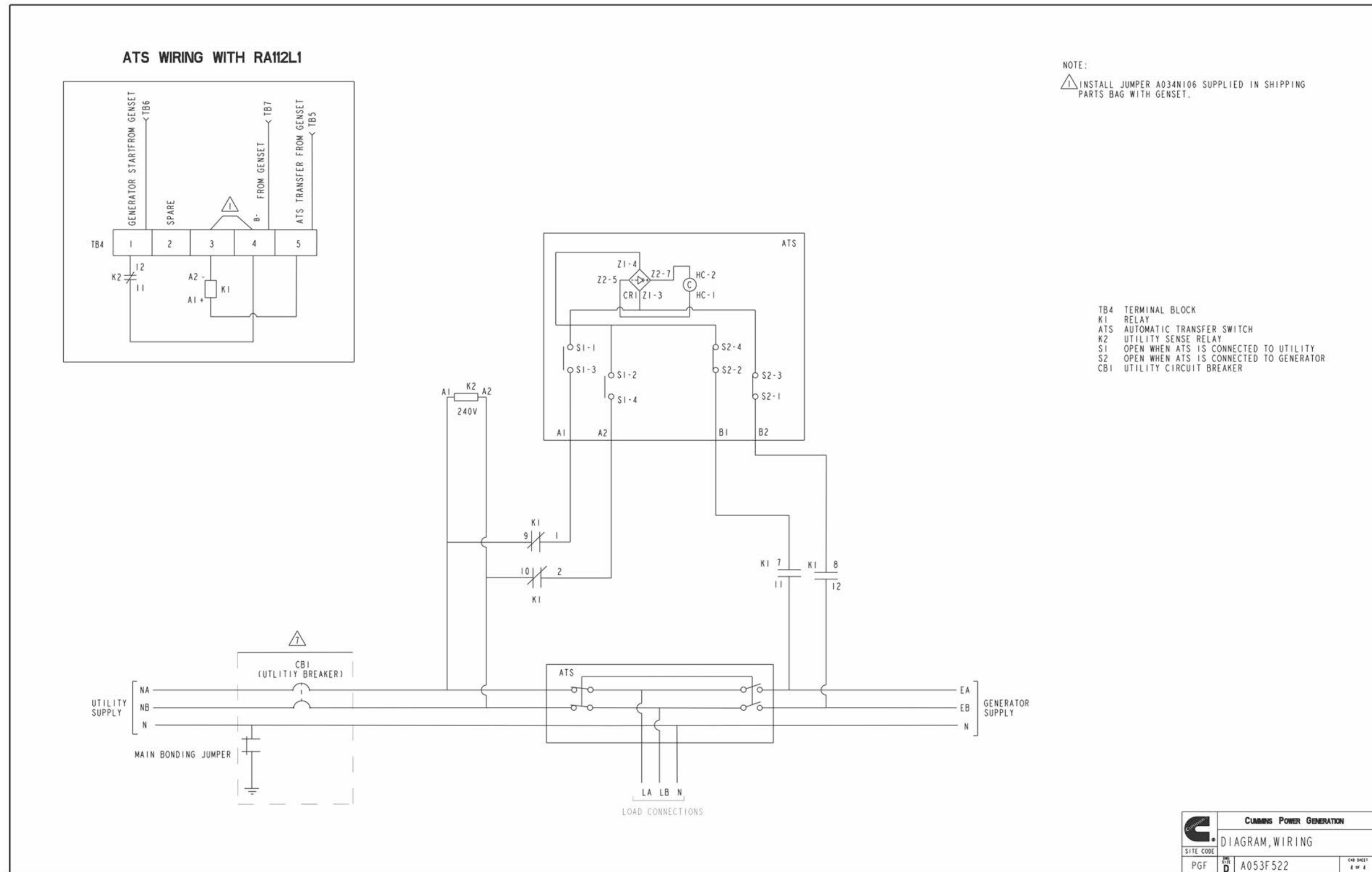

FIGURE 40. WIRING DIAGRAM (SHEET 4 OF 4)

LEAD NO	FROM			TO			WIRE		
	STATION	CONNECTOR	PIN	STATION	CONNECTOR	PIN	WIRE_GAUGE	COLOR	SPOOL_NAME
W-01	PI-5	0323-1819-01	0323-1614-01	DISPLAY PI-7	0323-2011	0323-2466	18	WHITE	A007P616
W-03	PI-32	0323-1819-01	0323-1614-01	DISPLAY PI-6	0323-2011	0323-2466	18	WHITE	A007P616
W-05	ENG GND1	0332-2964	NOT APPLY	SP1-1	0332-3638	NOT APPLY	16	WHITE	A007P614
W-06	PI-27	0323-1819-01	0323-1614-01	SP1-2	0332-3638	NOT APPLY	18	WHITE	A007P616
W-07	DISPLAY PI-5	0323-2011	0323-2466	SP1-2	0332-3638	NOT APPLY	18	WHITE	A007P616
W-08	SP2-2	0332-3638	NOT APPLY	PI-19	0323-1819-01	0323-1614-01	18	WHITE	A007P616
W-09	SP3-2	0332-3638	NOT APPLY	PI-26	0323-1819-01	0323-1614-01	18	WHITE	A007P616
W-10	SP4-2	0332-3638	NOT APPLY	PI-30	0323-1819-01	0323-1614-01	18	WHITE	A007P616
W-11	SP2-2	0332-3638	NOT APPLY	DISPLAY PI-1	0323-2011	0323-2466	18	WHITE	A007P616
W-12	DISPLAY PI-2	0323-2011	0323-2466	SP3-2	0332-3638	NOT APPLY	18	WHITE	A007P616
W-13	SP4-2	0332-3638	NOT APPLY	DISPLAY PI-3	0323-2011	0323-2466	18	WHITE	A007P616
W-14	DISPLAY PI-4	0323-2011	0323-2466	PI-14	0323-1819-01	0323-1614-01	18	WHITE	A007P616
W-15	SERVICE-J5-1	A044H291	0323-1491	SP1-2	0332-3638	NOT APPLY	18	WHITE	A007P616
W-16	SP3-2	0332-3638	NOT APPLY	SERVICE-J5-4	A044H291	0323-1491	18	WHITE	A007P616
W-17	SP2-2	0332-3638	NOT APPLY	SERVICE-J5-3	A044H291	0323-1491	18	WHITE	A007P616
W-18	PI-25	0323-1819-01	0323-1614-01	JE-1	0323-2237	A040M659	16	WHITE	A007P614
W-19	SP6-2	0332-3638	NOT APPLY	ENG GND2	0332-1048	NOT APPLY	16	WHITE	A007P614
W-20	OIL P-1	A043H382	A035D470	PI-6	0323-1819-01	0323-1614-01	18	WHITE	A007P616
W-22	ACT POS	0332-1992	NOT APPLY	PI-23	0323-1819-01	0323-1614-01	18	WHITE	A007P616
W-23	ACT NEG	0332-1992	NOT APPLY	ENG GND 2	0332-1048	NOT APPLY	18	WHITE	A007P616
W-24	SP8-2	0332-2947	NOT APPLY	CT1-1	A028X144	NOT APPLY	18	WHITE	A007P616
W-25	SP9-2	0332-2947	NOT APPLY	CT2-1	A028X144	NOT APPLY	18	WHITE	A007P616
W-26	PI-11	0323-1819-01	0323-1614-01	STARTER SW	0332-1993	NOT APPLY	16	WHITE	A007P614
W-27	STARTER B+1	0332-1194	NOT APPLY	PI-9	0323-1819-01	0323-1614-01	16	WHITE	A007P614
W-28	STARTER B+1	0332-1194	NOT APPLY	PI-8	0323-1819-01	0323-1614-01	16	WHITE	A007P614
W-30	PI-2	0323-1819-01	0323-1614-01	AC-P-1	A042N319	A043L492	18	WHITE	A007P616
W-31	PI-3	0323-1819-01	0323-1614-01	AC-P-2	A042N319	A043L492	18	WHITE	A007P616
W-32	PI-34	0323-1819-01	0323-1614-01	AC-P-4	A042N319	A043L492	18	WHITE	A007P616
W-33	PI-35	0323-1819-01	0323-1614-01	AC-P-3	A042N319	A043L492	18	WHITE	A007P616
W-34	FIELD NEG	0332-1992	NOT APPLY	PI-1	0323-1819-01	0323-1614-01	18	WHITE	A007P616
W-35	FIELD POS	0332-1992	NOT APPLY	PI-13	0323-1819-01	0323-1614-01	18	WHITE	A007P616
W-36	PI-15	0323-1819-01	0323-1614-01	SP8-1	0332-2947	NOT APPLY	18	WHITE	A007P616
W-37	SP5-2	0332-2947	NOT APPLY	CT COM1	A028X144	NOT APPLY	18	WHITE	A007P616
W-38	SP5-1	0332-2947	NOT APPLY	PI-17	0323-1819-01	0323-1614-01	18	WHITE	A007P616
W-39	PI-18	0323-1819-01	0323-1614-01	SP9-1	0332-2947	NOT APPLY	18	WHITE	A007P616
W-40	CT COM2	A028X144	NOT APPLY	SP5-2	0332-2947	NOT APPLY	18	WHITE	A007P616
W-41	PI-24	0323-1819-01	0323-1614-01	TB2-2	A034P713	0332-3491-01	18	WHITE	A007P616
W-42	P2-6	0323-2516	0323-1614-01	TB1-2	A034P713	0332-3491-01	18	WHITE	A007P616
W-43	PI-7	0323-1819-01	0323-1614-01	TB3-2	A034P713	0332-3491-01	18	WHITE	A007P616
W-44	TB4-2	A034P713	0332-3491-01	P2-7	0323-2516	0323-1614-01	18	WHITE	A007P616
W-45	P2-3	0323-2516	0323-1614-01	TB5-2	A034P713	0332-3491-01	18	WHITE	A007P616
W-46	P2-4	0323-2516	0323-1614-01	TB6-2	A034P713	0332-3491-01	18	WHITE	A007P616
W-49	SP4-2	0332-3638	NOT APPLY	TB8-5	A046D267	0332-3491-01	18	WHITE	A007P616
W-51	ENG GND2	0332-1048	NOT APPLY	TB7-5	A046D267	0332-3491-01	18	WHITE	A007P616
W-52	SP6-2	0332-3638	NOT APPLY	FSGND 1	0332-1992	NOT APPLY	18	WHITE	A007P616
W-53	SP6-2	0332-3638	NOT APPLY	FSGND 2	0332-1992	NOT APPLY	18	WHITE	A007P616
W-54	SP7-2	0332-2947	NOT APPLY	FSOL 1+	0332-1992	NOT APPLY	18	WHITE	A007P616
W-55	SP7-2	0332-2947	NOT APPLY	FSOL 2+	0332-1992	NOT APPLY	18	WHITE	A007P616
W-56	OIL LVL	A052Y617	NOT APPLY	P2-5	0323-2516	0323-1614-01	18	WHITE	A007P616
W-57	TEMP	0332-1992	NOT APPLY	PI-33	0323-1819-01	0323-1614-01	18	WHITE	A007P616
W-58	TGND	0332-1992	NOT APPLY	ENG GND 1	0332-2964	NOT APPLY	18	WHITE	A007P616
W-59	BC-P-1	A042N319	A043L492	STARTER B+2	0332-1194	NOT APPLY	16	WHITE	A007P614
W-60	BC-P-2	A042N319	A043L492	ENG GND 3	0332-2964	NOT APPLY	16	WHITE	A007P614
W-61	BC-P-3	A042N319	A043L492	TB-LINE-2	A046D267	0332-3491-01	16	WHITE	A007P614
W-62	BC-P-4	A042N319	A043L492	TB-NEUTRAL-2	A046D267	0332-3491-01	16	WHITE	A007P614
W-63	BATT HTR -L	0332-1993	NOT APPLY	TSTAT-1	0332-1995	NOT APPLY	16	WHITE	A007P614
W-64	OIL HTR -L	0332-1993	NOT APPLY	TSTAT-1	0332-1995	NOT APPLY	16	WHITE	A007P614
W-65	P2-8	0323-2516	0323-1614-01	TB9-2	A034P713	0332-3491-01	18	WHITE	A007P616
W-66	BATT HTR -N	0332-1993	NOT APPLY	TB-NEUTRAL-3	A046D267	0332-3491-01	16	WHITE	A007P614
W-67	OIL HTR -N	0332-1993	NOT APPLY	TB-NEUTRAL-4	A046D267	0332-3491-01	16	WHITE	A007P614
W-68	ALT HTR -N	0332-1993	NOT APPLY	TB-NEUTRAL-5	A046D267	0332-3491-01	16	WHITE	A007P614
W-69	ALT HTR -L	0332-1993	NOT APPLY	TB-LINE-5	A046D267	0332-3491-01	16	WHITE	A007P614
W-70	TSTAT-2	0332-1993	NOT APPLY	TB-LINE-3	A046D267	0332-3491-01	16	WHITE	A007P614
W-71	ENG GND2	0332-1048	NOT APPLY	JE-2	0323-2237	A040M659	16	WHITE	A007P614
W-72	PE-1	0323-2098	0323-2332	SP7-1	0332-2947	NOT APPLY	16	WHITE	A007P614
W-73	PE-2	0323-2098	0323-2332	PI-16	0323-1819-01	0323-1614-01	16	WHITE	A007P614

NOTES:

- TOLERANCES: UP TO 500 +15/-5
500 TO 1000 +30/-10
1000 TO LONGER +40/-20
- ALL LEADS/WIRES SHALL BE MARKED AT MAXIMUM OF 76 mm BEHIND THE CONNECTOR WITH BOTH STATION NUMBERS LISTED IN THE "FROM-TO" TABULATION. MARKING SHALL BE PERMANENT AND LEGIBLE. WIRE MARKINGS NEED TO HAVE FULL VISUAL ACCESS. END MARKINGS ARE NOT TO BE VISUALLY OBLSCURED AND MUST BE FULLY DISPLAYED. TO/FROM DESIGNATIONS ARE NOT TO BE FRAGMENTED. DESIGNATOR SHALL APPEAR IN FULL TEXT AND NOT IN BROKEN SEGMENTS.
- USE CABLE TIES (0332-3388) AS REQUIRED TO SECURE WIRES.
- HARNESS MUST BE PROCURED FROM A SUPPLIER QUALIFIED AS A UL RECOGNIZED HARNESS MANUFACTURER CATEGORY (ZPFW2). PACKAGING OF PARTS TO BE MARKED IN ACCORDANCE WITH REQUIREMENTS SPECIFIED BY SUPPLIER'S UL PROGRAM.
- STAGGER AND COVER ALL UNINSULATED FASTONS, SPLICES, RING TERMINALS & RESISTORS WITH HEAT SHRINK (0898-1337-03).
- IF THE VALUE OF 0 (ZERO) IS USED IN THE BILL OF MATERIAL, THE QUANTITY OF THE AFFECTED ITEMS SHALL BE DERIVED FROM THE DRAWING REQUIREMENTS.
- USE TESA 51026 CLOTH WIRE TAPE OR EQUIVALENT CLOTH TAPE TO COVER THE HARNESS.
- ATTACH A MASTER HARNESS LABEL WITH THE FOLLOWING INFORMATION: CUMMINS PART NUMBER, CUMMINS PART REVISION LEVEL, MANUFACTURER'S NAME, MANUFACTURER'S LOCATION, AND MANUFACTURER'S DATE OF MANUFACTURE IN THE FORMAT OF MONTH, DATE, LAST 2 YEAR DIGITS. LABEL MUST BE MADE FROM UL RECOGNIZED VINYL SELF LAMINATION LABEL SYSTEM.
- TWISTED WIRE PAIRS SHOULD HAVE MINIMUM OF 5 TWIST PER FOOT.
- COMPONENTS CT1 AND CT2 ARE PART OF ASSEMBLY A028X144. ADJUST LEAD LENGTHS AS REQUIRED. LABEL AS "CT1" AND "CT2".
- INK FOR HARNESS MARKING, MUST RESIST ERASER ABRASION TEST, ANTIFREEZE, MOTOR OIL, TRANSMISSION FLUID, GASOLINE, DIESEL FUEL & BRAKE FLUID.
- MANUFACTURE TO IPC/WHMA-A-620 WORKMANSHIP STANDARD.
- POINT TO POINT CONTINUITY TEST MUST BE PERFORMED ON THIS HARNESS ASSEMBLY.
- PLACE INDIVIDUAL LABEL WITH FOLLOWING DETAIL
TB1 : "TB1-LOAD CONTROL1", TB2 : "TB2-LOAD CONTROL2", TB3 : "TB3-LOAD CONTROL3", TB4 : "TB4-LOAD CONTROL4", TB5 : "TB5-ATS TRANSFER", TB6 : "TB6-REMOTE START", TB7 : "TB7-GROUND", TB8 : "TB8-FUSED B (IA)", TB9 : "TB9-ALARM OUTPUT", TB LINE : "LINE" & TB NEUTRAL : "NEUTRAL".
- COIL UP & TIE WRAP THE BRANCH TO THE MAIN BRANCH TO ALLOW IT TO BE REPOSITIONED DURING GENSET INSTALLATION.
- ATTACH A LABEL WITH UL MARK (UL SYMBOL AND OTHER UL REQUIRED INFORMATION) IN ACCORDANCE WITH REQUIREMENTS SPECIFIED BY THE SUPPLIER'S UL PROGRAM.
- (NOTE REMOVED).
- NO LOOP OR RADIUS REQUIRED, THIS IS JUST A DRAWING REPRESENTATION.
- PLUG CONNECTOR "PE" INTO CONNECTOR "JE".

TWISTED WIRE

CUMMINS POWER GENERATION			
HARNESS, GENSET			
SITE CODE	REV	DWG NO	SHEET NO
PGF	D	A049F902	1 OF 3

FIGURE 41. HARNESS, GENERATOR SET ELECTRICAL (SHEET 1 OF 3)

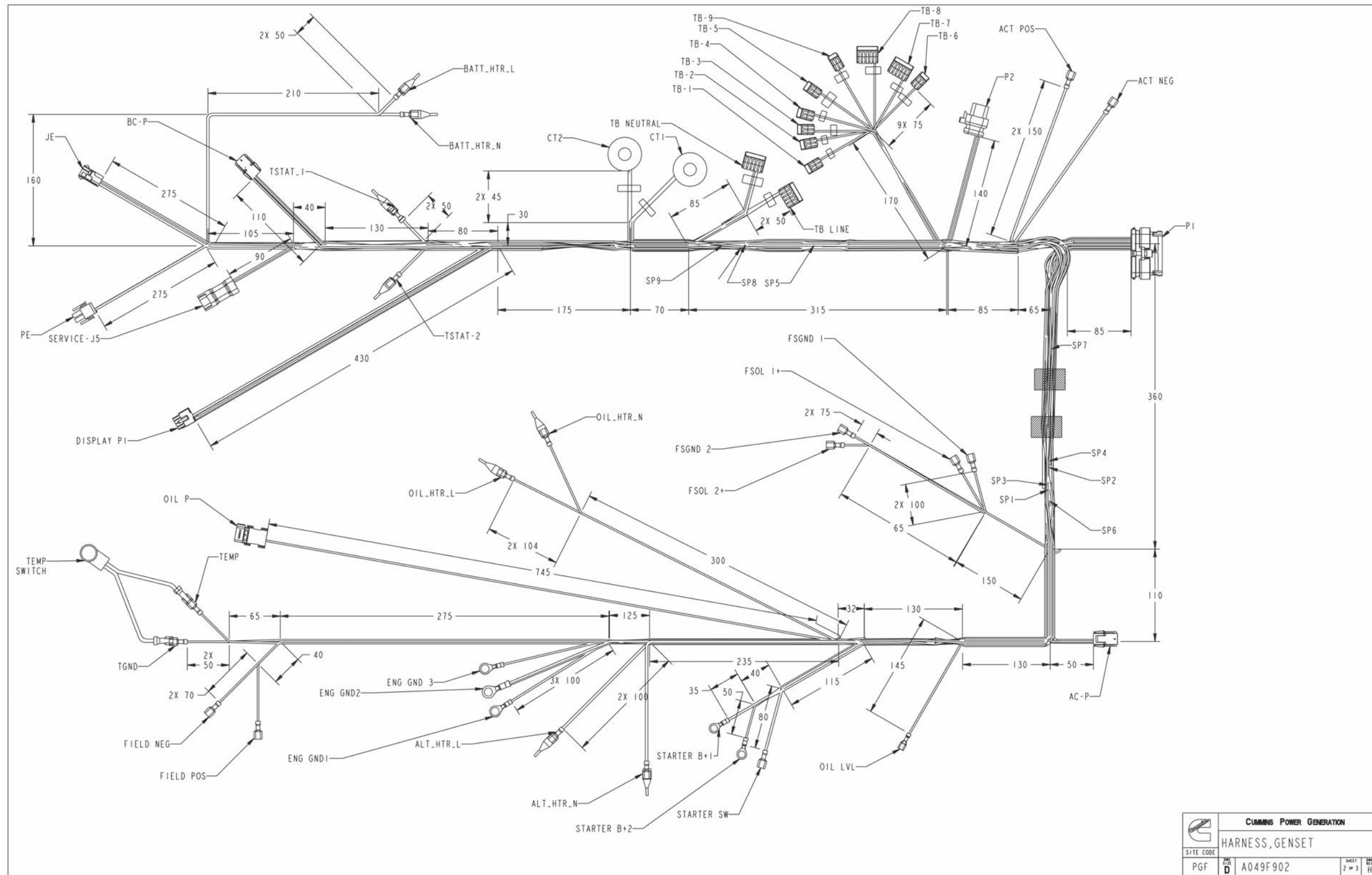

FIGURE 42. HARNESS, GENERATOR SET ELECTRICAL (SHEET 2 OF 3)

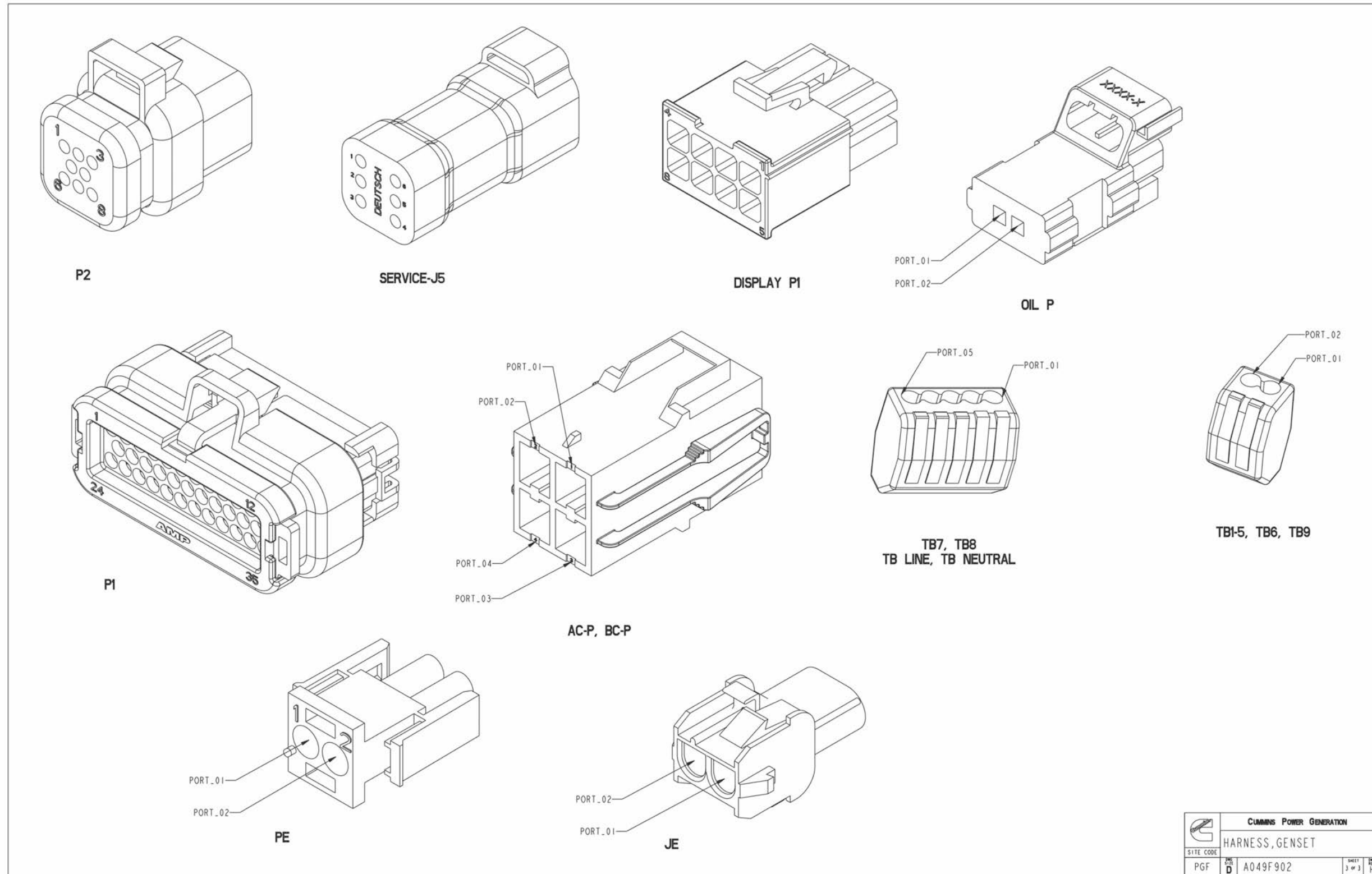

FIGURE 43. HARNESS, GENERATOR SET ELECTRICAL (SHEET 3 OF 3)

This page is intentionally blank.

power.cummins.com

Copyright © 2016 Cummins Inc. All rights reserved.

Cummins, Onan, the "C" logo, and "Performance you rely on." are trademarks of Cummins Inc.

Other company, product, or service names may be trademarks or service marks of others.

Specifications are subject to change without notice.

