

FIRST DEGREE FITNESS
Fluid INNOVATION

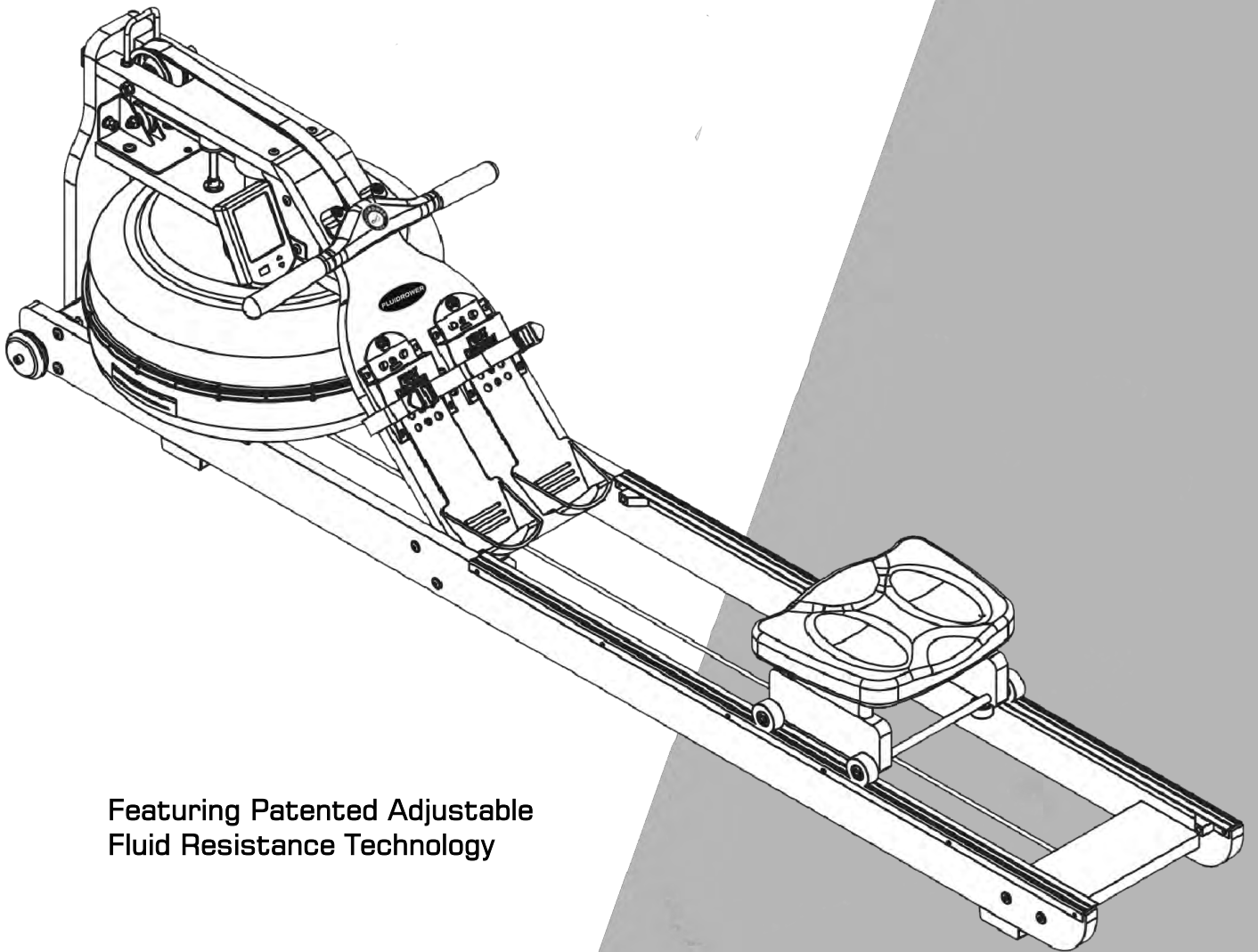

» USER GUIDE

VIKING 2 PLUS



Featuring Patented Adjustable
Fluid Resistance Technology

REGISTER YOUR PRODUCT AT WWW.FIRSTDEGREEFITNESS.COM/SUPPORT

» Introduction

Congratulations on your purchase of the Rower.

FIRST DEGREE FITNESS is proud to present the Rower as a home use product featuring patented Adjustable Fluid Resistance.

Our solid wood frames incorporate only the highest quality American Ash which is collected using the latest technology in sustainable harvesting from renewable plantations.

Note that slight variations of colour are normal and part of Mother nature's artistry. The wood grain patterns and subtle hues of each Rower makes every unit highly individual and designed to compliment any environment.

Follow all instructions carefully for correct assembly, tank filling, water treatment, service and safety.

Access to our world-wide distributor and service network is available at www.firstdegreefitness.com

Check contents of Box 1 and 2 to ensure all parts are present and correct prior to assembly.

Training With The Rower

1. As with any piece of fitness equipment, consult a physician before beginning your Rower exercise program.
2. Follow instructions provided in this manual for correct foot position and basic rowing techniques.
3. For more detailed rowing techniques, please refer to our international website at www.firstdegreefitness.com

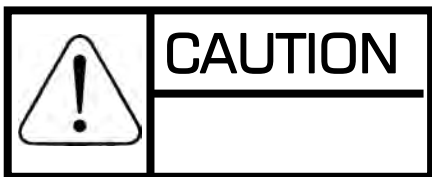

1. Keep hands and fingers away from moving parts, as indicated in this manual.
2. The Rower can stand vertically for storage. Make sure a secure location is chosen, such as the corner of a room or against a wall on an even, secure surface.

Note: If the storage area is not level, an additional fixture is required (sold separately) to keep the Rower stable with vertical storage position.

» Contents

Safety	5
Assembly	7
Rower Box 1 & 2 Contents	8
Assembly Instructions.....	9
Operation Instructions.....	13
Using the FIRST DEGREE FITNESS USB Interface	16
Monitor Operation.....	17
Detaching the Rower Belt.....	18
Reattaching the Rower Belt.....	19
Maintenance	20
Troubleshooting.....	21
Optional Fixture Kit Installation.....	22
International Warranty	23

» Safety

Safety Information

- Before using this product, it is essential to read this ENTIRE operation manual and ALL instructions. The Rower is intended for use solely in the manner described in this manual.
- UNDERSTANDING EACH AND EVERY WARNING TO THE FULLEST IS IMPORTANT
- As with any piece of fitness equipment, consult a physician before beginning your Rower exercise program.
- Please be aware that any fitness regime, before being undertaken, is best preceded by a physical checkup from a certified physician.
- Injuries to health may result from incorrect or excessive training.
-  **WARNING** Heart rate monitoring systems may be inaccurate. Over exercise may result in serious injury or death. If you feel faint, stop exercising immediately.
- Stop the machine immediately if any signs of excessive wearing is present on the Belts, pulleys and bungee cords. Do not use unit until said parts are repaired or replaced.
- Do not allow children unattended access to the machine.
- The Rower can stand vertically for storage. When doing so, please follow the instructions given in the manual.
- Please keep hands away from moving parts, as indicated by the warning label on the Main Frame of your machine.
- If any of the adjustment devices are left projecting, they could interfere with the user's movement.
- Do not store in freezing conditions with water in the tank as it can expand and crack the components.

Installation

- Place on a stable, flat surface in a horizontal position during use for maximum stability.
- Check all Belts, pulleys and bungee cords regularly for signs of wear, and replace if needed.
- Check regularly and follow all instructions for maintenance as specified in this manual.
- Replace immediately any defective parts and do not operate unit until all repairs are complete.

» Safety





Proper Usage

- Do not use any equipment in any way other than designed or intended by the manufacturer. It is imperative that FIRST DEGREE FITNESS equipment is used properly to avoid injury.
- Injuries may result if exercising improperly or excessively. It is recommended that all individuals consult a physician prior to commencing an exercise program. If at any time during exercise you feel faint, dizzy or experience pain, STOP EXERCISING and consult your physician.
- Keep body parts (hands, feet, hair, etc.), clothing and jewelry away from moving parts to avoid injury.
- Follow instructions provided in this manual for correct foot position and basic rowing techniques.
- For more detailed rowing techniques, please refer to our International website www.firstdegreefitness.com

Inspection

- DO NOT use or permit use of any equipment that is damaged and/or has worn or broken parts. For all FIRST DEGREE FITNESS equipment use only replacement parts supplied by FIRST DEGREE FITNESS.
- Cables and Belts pose an extreme liability if used when frayed. Always replace any cable or Belt at first sign of wear (consult FIRST DEGREE FITNESS if uncertain).
- EQUIPMENT MAINTENANCE - Preventative maintenance is the key to smooth operating equipment as well as to keep your liability to a minimum. Equipment needs to be inspected at regular intervals.
- Ensure that any person(s) making adjustments or performing maintenance or repair of any kind is qualified to do so.
- DO NOT ATTEMPT TO USE OR REPAIR ANY ACCESSORY APPROVED FOR USE WITH THE FIRST DEGREE FITNESS EQUIPMENT WHICH APPEARS TO BE DAMAGED OR WORN.
- Check all Belts, pulleys and bungee cords regularly for signs of wear, and replace if needed.
- Check regularly and follow all instructions for maintenance as specified in this manual.
- Replace immediately any defective parts and do not operate unit until all repairs are complete.

Operating Warnings

- Keep children away from the equipment. Parents or others supervising children must provide close supervision of children if the equipment is used in the presence of children.
- Do not allow users to wear loose fitting clothing or jewelry while using equipment. It is also recommended to have users secure long hair back and up to avoid contact with moving parts.
- All bystanders must stay clear of all users, moving parts and attached accessories and components while machine is in operation.
-  **WARNING** Do not insert fingers into tank!
-  **CAUTION** After rowing exercise, please allow the unit to sit for 5 minutes before standing it up for storage.
-  **CAUTION** Do not fill past the calibration mark as indicated on the tank level sticker or water spillage can occur.
-  **WARNING** Never operate this Rower without feet properly secured in Footstraps, or without the sliding portion of the Slider Footplate locked into position!

» Assembly

Product Specifications

Product Class: HC

Braking System: Speed Independent

Product Net Weight: 32.7kg (72.09lbs)

Product Gross Weight: 38.2kg (84.22lbs)

Minimum Safe Operating Surface Area: 333cm (131.09") x 172cm (67.71")

Dimensions: 2130mm (83.86") Length x 520mm (20.47") Width x 580mm (22.83") Height

Maximum User Weight: 150kg (330lbs)

Compact Footprint: 2730mm x 1120mm or upright 580mm x 520mm

Product Highlights

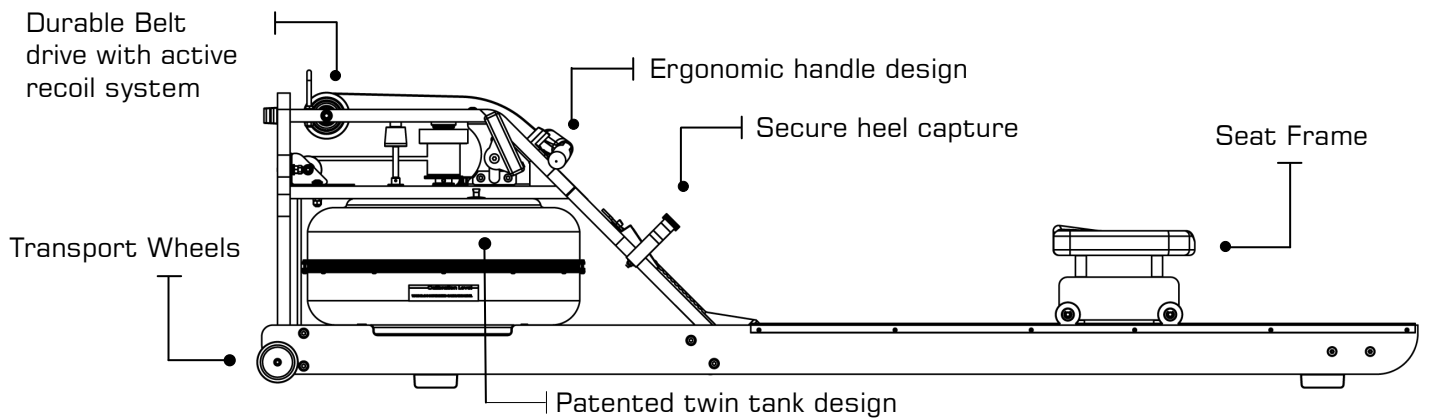

The live area shall be not less than 60cm (23.62") greater than the training area in the directions from which the equipment is accessed. The live area must also include the area for emergency dismount.

Live area and Training area

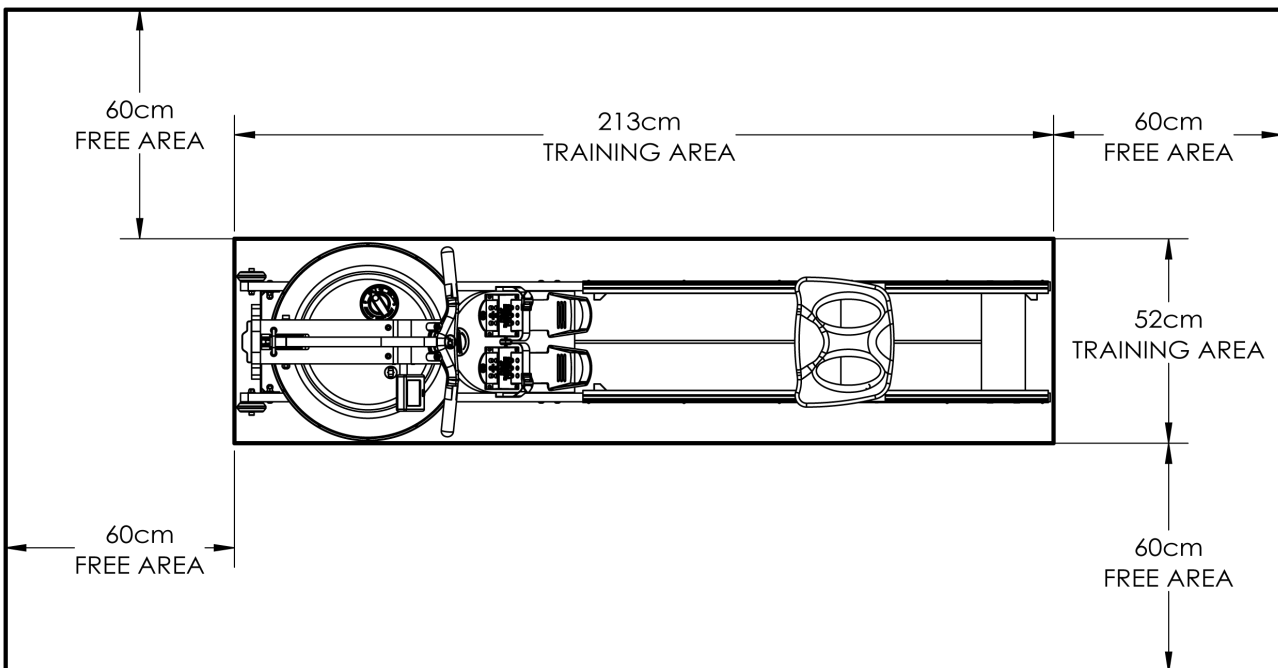

Note: Rower is not suitable for therapeutic purposes.

» Rower Box 1 & 2 Contents

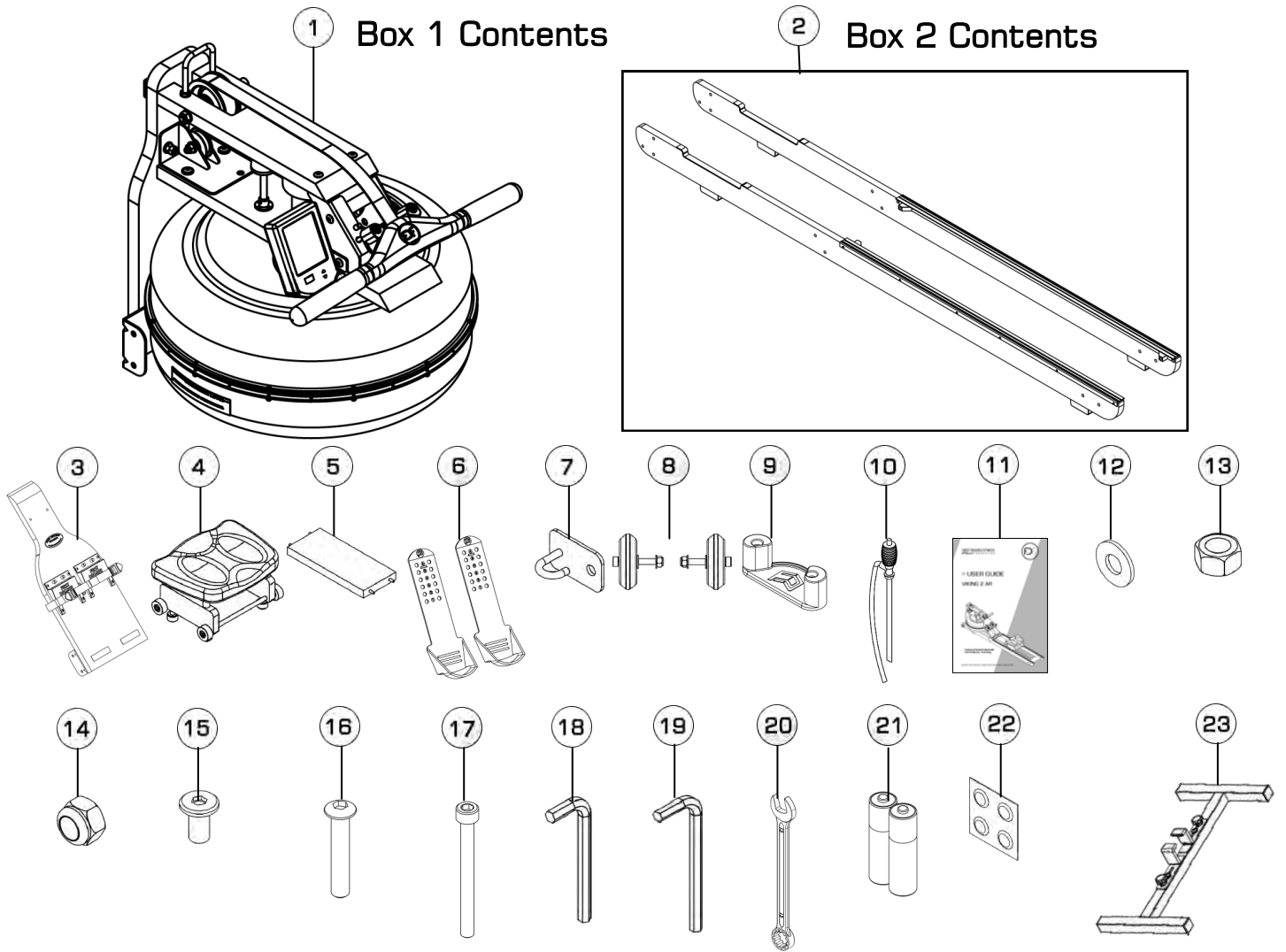

Item	Qty.	Description	Item	Qty.	Description
1	1	Main Frame	7	1	Bungee Hook Mount
2	2	Left / Right Side Rail	8	2	Transport Wheel Assembly
3	1	Footboard	9	1	Rower Handle Bar Catch
4	1	Rower Seat	10	1	Siphon
5	1	Rear Brace	11	1	User Guide
6	2	Footplate			
Hardware KIT					
12	16	M8 Washer	18	1	5mm Allen Key
13	8	M8 Standard Nut	19	1	6mm Allen Key
14	8	M8 Nyloc Nut	20	1	13mm Spanner
15	4	M6x15mm Bolt	21	2	AA Battery
16	8	M8x45mm Bolt	22	4	Water Treatment Tablet
17	2	M6x65mm Bolt			
Optional Equipment (Not Included)					
23	1	Optional Stand (not included)			

» Assembly Instructions

STEP 1 Rear Brace Assembly and Left/Right Side Rails

REQUIRED

- Side Rail Left / Right [2]
- Rear Brace [5]
- Bungee Hook Mount [7]
- Transport Wheel Assembly [8]
- 4x M6x15mm Bolts [15]

! WARNING

Rotate Rear Brace to correct orientation before assembly onto Side Rails

- a) Start with the **Rear Brace** and on the underside you will find a **Pre-installed bolt**. From the hardware kit, take the **Bungee Hook Mount** and install it onto the Rear Brace as shown. Note the orientation of the Brace and hook must be correct in order to hold the end of the **Bungee Shock Cord** as depicted by the arrow in the illustration, which points toward the front of Rower.

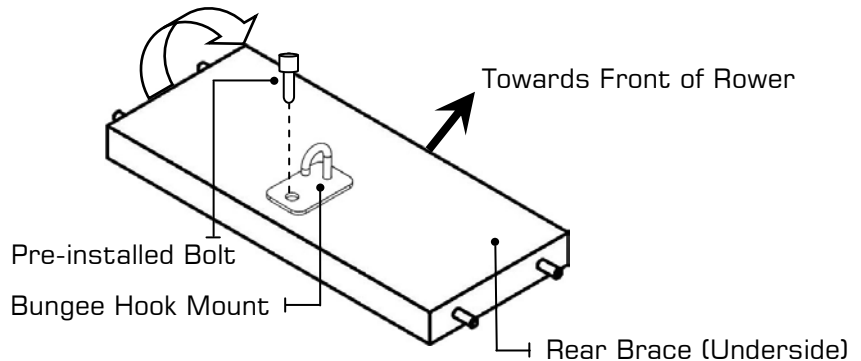

! WARNING

Note Transport Wheels must be mounted on the outside of Side Rails as shown on the right.

Do not over tighten the Transport Wheel Axle as it may inhibit Transport Wheel rotation.

- b) Next, connect the **Side Rail Left** and **Side Rail Right**[2] using **4x M6x15mm Bolts**[15] and **Rear Brace**[5]. **DO NOT TIGHTEN.**

Tip: Bumpstops facing inside of Rail for correct assembly orientation.

- c) Once the Rear Brace and Side Rails are assembled, mount the **Transport Wheel Assembly**[8] onto the **Left/Right Side Rails**[2].

Note: One washer on outside and one washer on the inside of the Side Rail.

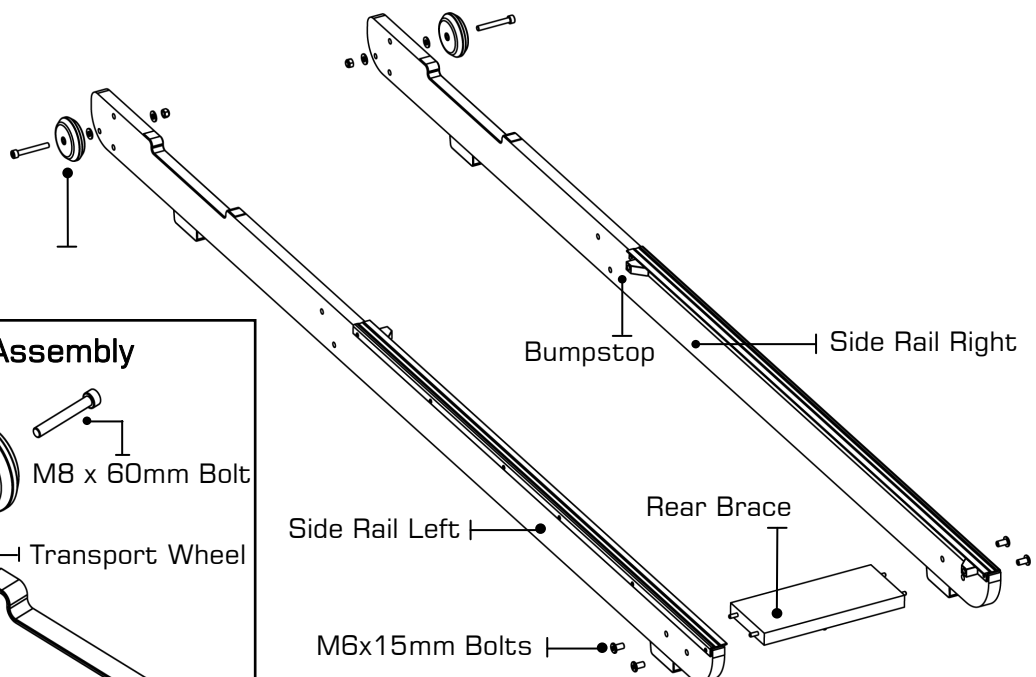

Transport Wheel Assembly

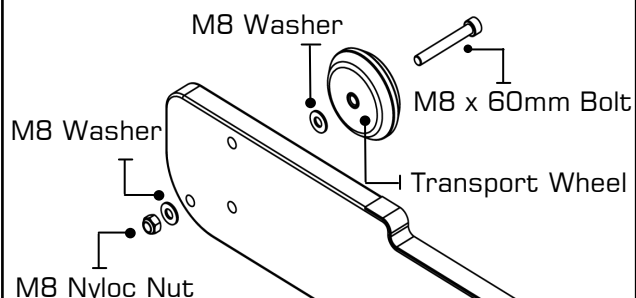

» Assembly Instructions

STEP 2 Mounting Rower Seat and Upper Main Frame

REQUIRED

- Left/Right Side Rails [2]
- Rower Seat [4]

To install the Rower Seat, spread the **Left/Right Side Rails**[2] slightly and drop the **Rower Seat**[4] into the track.

Note Seat indentation must face rearward.

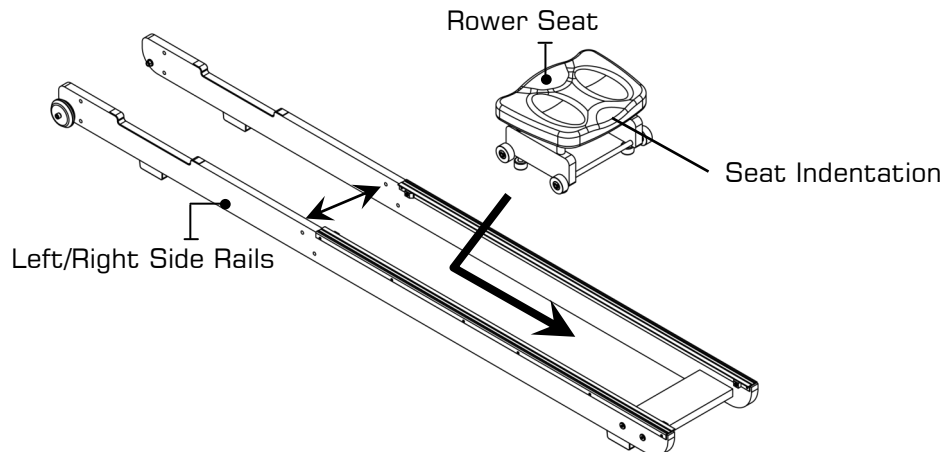

STEP 3

REQUIRED

- Main Frame [1]
- 8x M8 Washers [12]
- 4x M8 Standard Nuts [13]
- 4x M8 Nyloc Nuts [14]
- 4x M8x45mm Bolts [16]

Next, install the **Main Frame**[1] onto the **Side Rail Assembly** as shown. You will need **4x M8x45mm Bolts**[16], **8x M8 Washers**[12], **4x M8 Standard Nuts**[13] and **4x M8 Nyloc Nuts**[14].

Secure but **DO NOT TIGHTEN**. You will find that the Lower Bracket Bolts can be difficult to access. You can tighten these bolts completely with the Rower standing in the Vertical position easily once the Footboard has been mounted, so for the moment, simply align and loosely thread

CAUTION

Nyloc Nuts must be outside the Standard Nut and Washer to properly secure assembly.

Note: Clean Wheels and Tracks weekly with a soft dry cloth in order to decrease the rate of wear on both Wheels and Track.

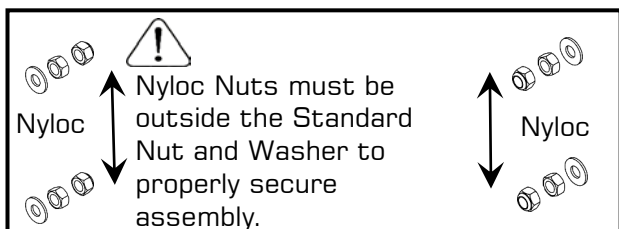
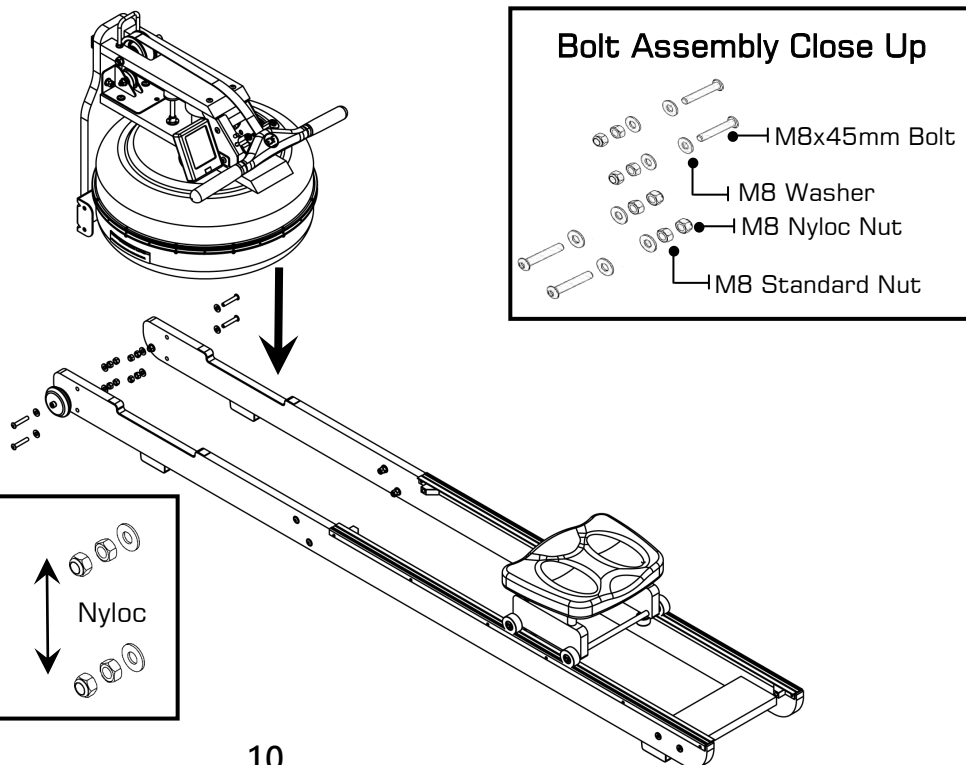

» Assembly Instructions

STEP 4 Attaching Footboard onto Main Frame

REQUIRED

- Footboard [3]
- Footplate [6]
- Rower Handle Bar Catch [9]
- 8x M8 Washers [12]
- 4 x M8 Standard Nuts [13]
- 4 x M8 Nyloc Nuts [14]
- 4 x M8x45mm Bolts [16]
- 2 x M6x65mm Bolts [17]

- a) First, undo the Rower Handle and move forward. Then, install the **Footboard[3]** onto the Main Frame using the **Rower Handle Bar Catch[9]**, **2x M6x65mm Bolts[17]** for the top of the Footboard, and **4x M8x45mm Bolts[16]**, **8x M8 Washers[12]**, **4x M8 Standard Nuts[13]**, **4x M8 Nyloc Nuts[14]** for the Lower Footboard to Side Rail assembly. Tighten all assembly bolts once Footboard has been installed. **Note** the lower bolts are much easier to tighten with the Rower standing in the vertical position.

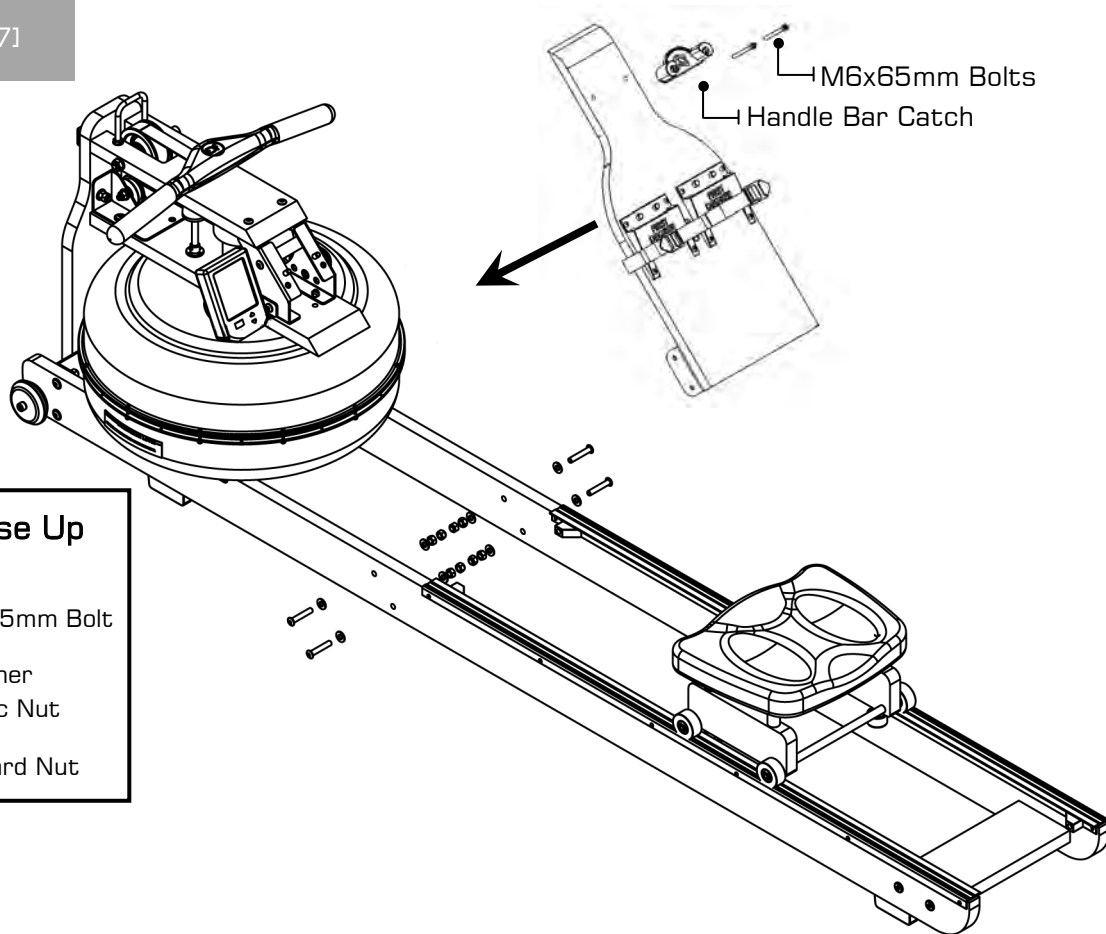

- b) Next, install **Footplate[6]** onto the **Footboard[3]** by sliding under the Footplate Frames.

Tip: When inserting Footplates, lift the front of the Footplate slightly.

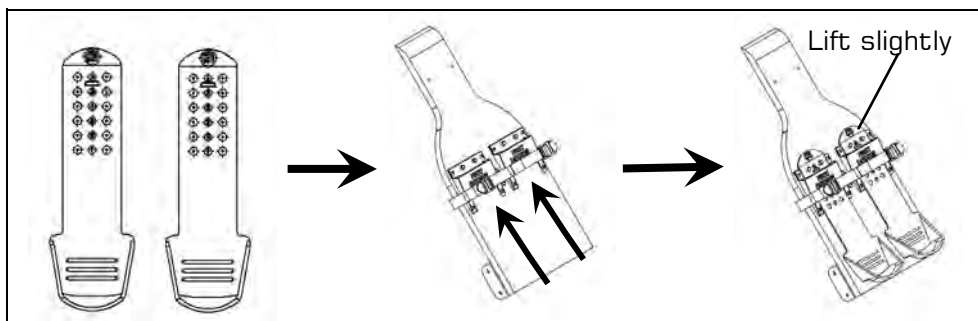

» Assembly Instructions

STEP 5

Attach Bungee Cord and Tighten Frame

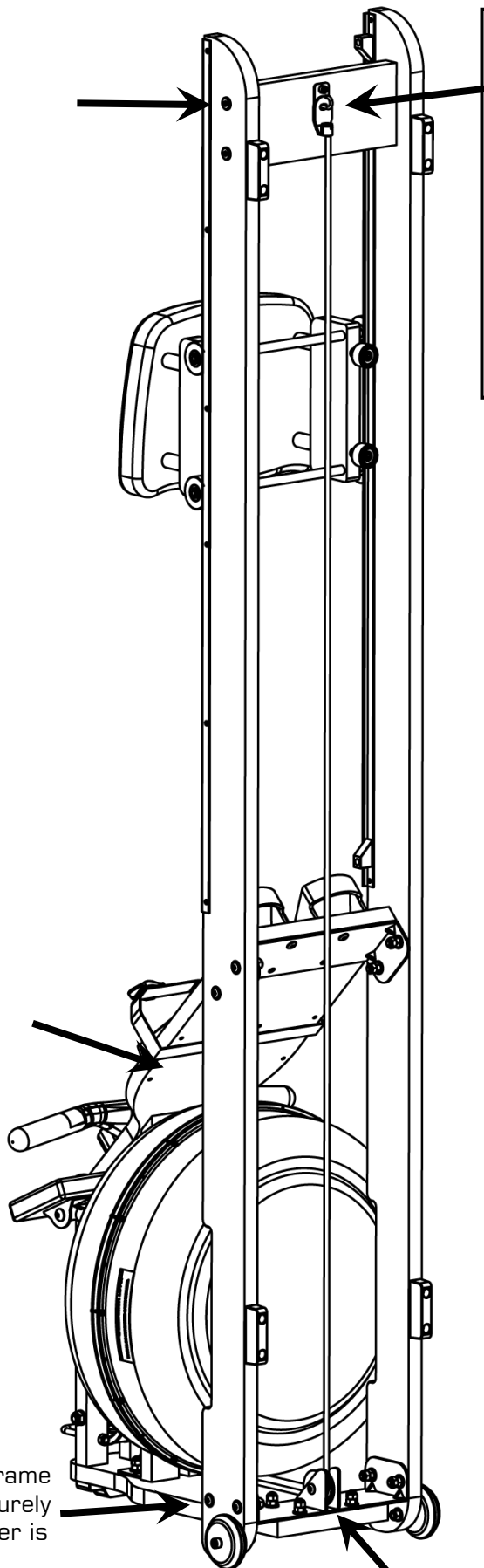

Tighten Frame Bolts securely once Rower is standing.

Pull Bungee Cord and Hook Bungee End onto the **Bungee Hook Mount**[7] as shown.



Do not cut Bungee tie wrap before Bungee Cord is attached to rear of Rower as shown here.

Once the Bungee Cord is attached to the Rear Brace, tighten the bolts holding the Footboard, the Main Frame to Side Rail Bolts as they are easier to access from the vertical position.

Lower the Rower back to the Horizontal position and test for proper bungee recoil.

Check Seat Rollers / Runners for dirt or debris before sitting on the Rower Seat. Small objects captured between the Seat Rollers and Runners can damage the Wheels or running surface. Check Runners for debris prior to each use and clean regularly.

Note: The Rower Frame Bolts require periodic checking for tightness. Do this at the end of the first month of use and again after every 12 months

Choose a suitable location when standing the product for storage.

The Rower Frame can be polished with any high grade furniture polish to further highlight the rich luster of the wood finish.

Install supplied 2x AA Battery and check Monitor function. Details regarding can be found in the Monitor section of this manual.

Choose a flat, level surface on which to use your Rower, to avoid rocking and potential premature wear.

Cut Bungee Tie wrap only after Bungee Hook is properly connected to Rear Brace.

»» Operation Instructions

»» Adjustable Resistance (AR) Tank

The Adjustable Resistance (AR) Tank, developed and patented by FIRST DEGREE FITNESS, offers a true multi-level experience. Water is moved between the "storage" and "active" chambers of the AR Tank. Your new Rowing Ergometer can adapt - at the turn of a dial - to the resistance preferred by each user.

Getting Started

To achieve minimum resistance, select "1" on the tank adjuster. **It takes 10 strokes to fill the central (storage) tank, leaving a minimal amount of water in the outer (active) tank. This process is always required if minimum resistance is desired.** Row hard at a steady pace (20 to 25 strokes per minute [SPM]) and put some effort into the stroke, ensuring that good form is maintained. You can make adjustments to the resistance level while you row. Your AR Tank will adapt almost instantly to increases in resistance but will take up to 10 strokes to reduce the effort required, as the central (storage) tank fills up.

Developing Your Routine

Once you have found a level that gives you the exercise required, changes can be made to SPM and to stroke intensity to further vary your energy input. Interval training is used by most Rowers, where a period of low intensity is combined with short intervals of high intensity. Your FDF Rowing Ergometer allows for changes 'on the fly', to achieve multi-level resistance profiles during a single workout. For more information on exercise routines, please visit our website at www.firstdegreefitness.com

»» Tank Filling and Water Treatment Procedures

REQUIRED
Siphon [10]

CAUTION
Resistance adjuster must be set to **LEVEL 4** to allow for accurate filling capacity.

WARNING
Do not overfill the tank beyond the maximum indicated level of 17 liters. Refer to the tank level decal on the lower side of the tank.

NOTE
In areas where tap water quality is known to be poor, FDF recommends the use of distilled water.

- Remove Tank Plug from the top of the tank.
 - Place a large bucket of water next to the Rower. Position the **Siphon[10]** with rigid hose in the bucket, and flexible hose in the tank.
- Note:** Make sure small breather valve on siphon is closed before filling.
- Squeeze siphon to begin filling. **Important:** Do not overfill tank
 - When full, open the valve on the top of the siphon to allow excess water to escape.
 - Once filling is completed follow the water treatment schedule below, then replace the tank plug.

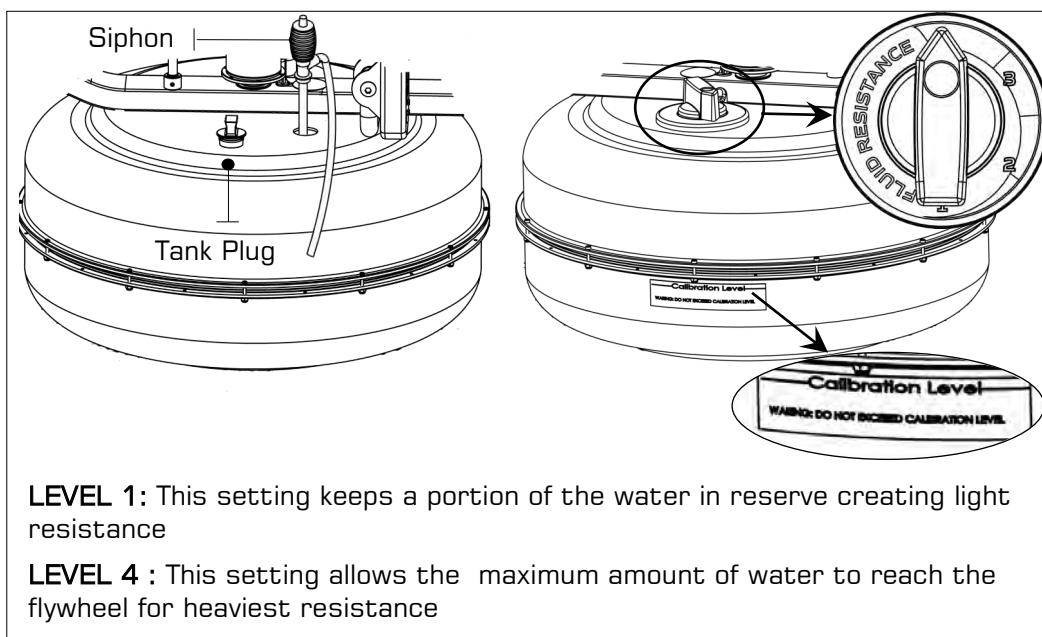

INITIAL WATER TREATMENT

Add 1 x Water Treatment Tablet per full tank. **DO NOT, UNDER ANY CIRCUMSTANCE, USE A WATER TREATMENT TABLET OTHER THAN THOSE SUPPLIED WITH YOUR UNIT.** Your unit purchase includes 4 x Water Treatment Tablets, which is sufficient for several years of use. To purchase additional Water Treatment Tablets, please consult your nearest regional dealer/distributor or check our website at www.firstdegreefitness.com

»» Operation Instructions

»» Removing/Changing Tank Water

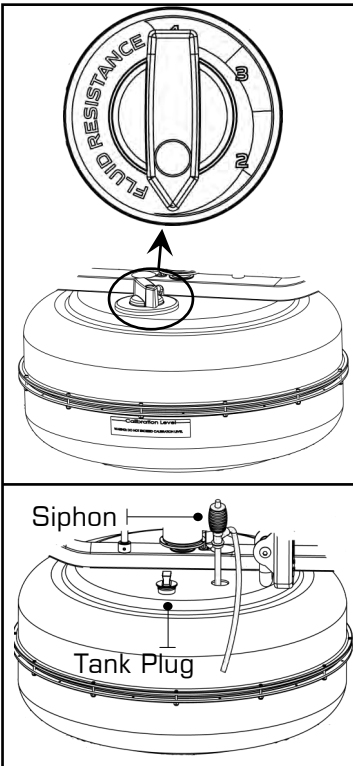

- a) Set Adjuster Knob to "1"
- b) Row at least ten strokes to fill the storage reservoir as completely as possible.
- c) Remove Tank Plug.
- d) Insert rigid end of siphon into the tank, and flexible hose into a large bucket.
- e) Drain tank (approx. 40% of water will remain) and then refill following directions for Tank filling as described in the Tank Filling section of this manual.

Note:

- ⊙ The valve on top of the siphon must be closed to allow proper drainage.
- ⊙ Water treatment will preclude the need to change tank water if the treatment schedule is maintained. Additional Water Treatment Tablet is required only when discoloration appears in the water.
- ⊙ Exposure to full sunlight reduces the life of the Water Treatment Tablets. Storing the Rower away from direct sunlight will extend the time between water treatments.
- ⊙ Approximately 40% of tank water will remain. It is not possible to completely drain the A/R tank without disassembly.

NOTE: For simple, fast and efficient filling and/or drainage of the Tank, we have a battery operated pump (rechargeable via USB) available as an option. We recommend this to any commercial facility, with multiple units, that has a need to drain and refill Tanks from time to time. To purchase, contact your nearest First Degree Fitness distributor or go to our website on www.firstdegreefitness.com for details.

»» Long Term Water Treatment and Basic Operation

Do not use any water treatment other than the tablets supplied with this unit. For replacement tablets, contact your local First Degree Fitness distributor. Water Treatment schedules for the ROWER will vary according to the tanks exposure to sunlight, but expect 8-12 months near a bright, sunlit window and 2 years or more for a darker location. At the point of finding the water slightly cloudy, add a Water Treatment Tablet.

! CAUTION
It is strongly recommended that a drop cloth be used under the Tank whenever the Tank Plug is opened for water treatment.

1. Select your preferred Fluid Resistance.
2. Match the level shown on Monitor with the tank Fluid Resistance using the UP/DOWN buttons.

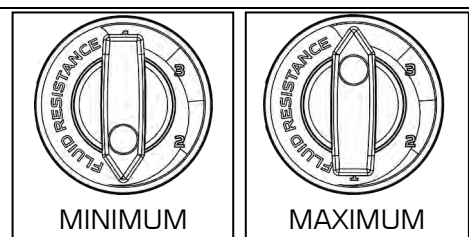

When adjusting resistance level, allow two strokes to feel an increase and ten strokes to feel a decrease.

»» Operation Instructions

»» Start Rowing

There are six phases to completing a rowing stroke

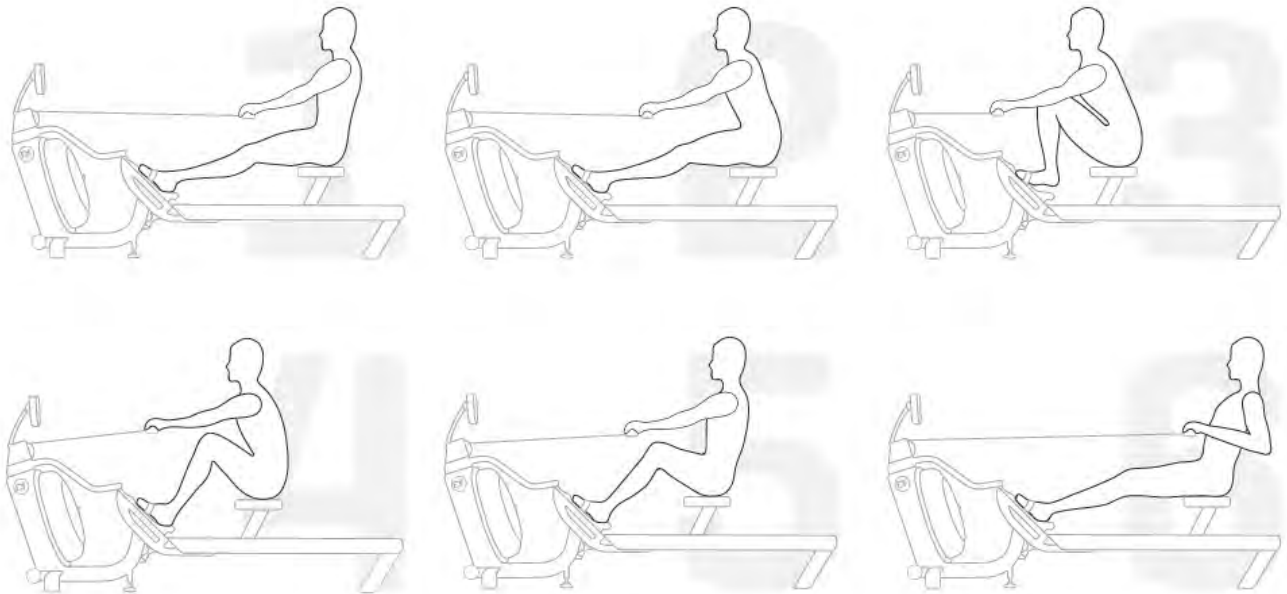

1. Sit with straight legs and back, leaning forward slightly at the hips with arms out straight and hands level with the lower ribs. Swing back.
2. Legs and back straight, leaning slightly forward from the hips, arms out in front. Lean and slide forward.

Note: Hands should now be around your knees, keeping legs straight.

3. Legs come forward, aiming to get the shins vertical. Back is still straight, and posture leaning slightly forward with arms still out front. Now drive hard, this is the CATCH.
4. Knees partially straightened so Seat is now at mid-point of travel, back and arms still straight. Maintain the stroke.
5. Knees are nearly straight, back is still straight but now leaning slightly back from the hips. Arms straight. Now squeeze through.
6. Legs now fully extended. Back straight and leaning slightly back, now pull with the arms so they are close to the chest, forearms horizontal and elbows close in to the rib cage. This is the FINISH.

For more information on correct rowing technique and workout tips visit our website www.firstdegreefitness.com/indoor-rowing-technique



CAUTION Always consult a doctor before beginning an exercise program.

Stop immediately if you feel faint or dizzy.

»» Operation Instructions

»» Adjust Footplates

The Footplate Slider accommodates most foot sizes, and is designed to keep your feet securely in place as you row. The feet should be positioned so that the Footstrap covers the section of the foot naturally bend as row. (e.g. The board of the foot)

TO ADJUST:

Lift the top of the Footplate from the mounting pegs and slide vertically between 1-6 to suit your foot length. Secure by hooking the Footplate back onto the mounting pegs and pushing down firmly to lock it into position. Place feet on the Footplates and tighten the Footstraps to ensure your feet sit firmly against the heel captures.

Note: The heel capture should bend to allow your foot to pivot naturally as you row.

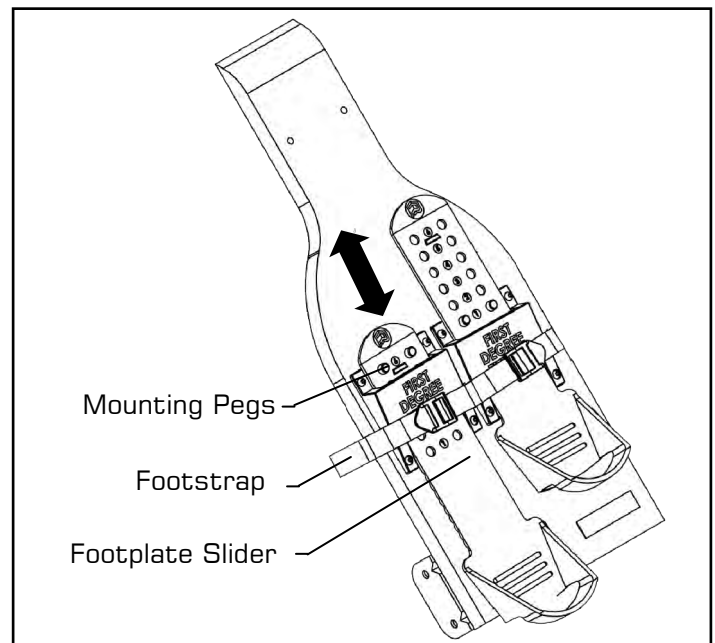

WARNING: Never operate this Rower without feet properly secured in Footstraps, or without the sliding portion of the Footplate Slider locked into position!

»» Using the FIRST DEGREE FITNESS USB Interface

Description:

The USB connectivity built into IPM and AR/AR+ Consoles models of your FDF Monitor allows you to enhance your exercise experience by connecting to your home PC or Laptop.

- Use FDF's Fluid Coach software to record and review your workout sessions.
- NetAthlon 2 XF for Rowers lets you race with other Internet connected Rowers or train solo. For interested developers, use our *USB Serial Protocol Guide* to develop your own apps for Windows or MacOS or try our Windows software samples with access to selected source code.
- OSD Ergometer – Row while watching your favorite movies
- Simple Sample (with source code) – Basic on-screen ergometer
- IPM Emulator – Full function on-screen IPM Ergometer

Setting Up USB connectivity

1. Connect your Monitor to your Laptop/PC (Windows 7/8/10). Windows should automatically install the latest USB driver.
2. Alternatively download and install the USB Device Driver from <https://www.ftdichip.com/Drivers/VCP.htm>
3. Download and Install the Fluid Coach software from the FDF Website. *Link Required*
4. Download and Install NetAthlon 2 XF for Rowers from <http://www.webracing.org/downloads.htm>

Connecting Your Monitor

- The USB Connector is located on a flying lead at the rear of the Monitor, along with the Sensor and Heart Rate Monitor Connectors.
- Connect to a Laptop or PC using a standard USB cable, you may need to wait while Windows starts the USB Device Driver.

Note: Please refer to monitor manual where applicable or for further information refer to our website at www.firstdegreefitness.com

» Monitor Operation

Functions

Auto Start: Commence rowing to activate.

Reset all values: Press and hold RESET button for 3 seconds.

Distance: Each single press of RESET adds 100m distance, up to 1000m then adds 500m.

Auto-Pause: A temporary halt in exercise will result in the following:

For over 5 seconds and under 5 minutes:

- a) SPM/500METER/WATT to zero.
- b) Distance/TIME values are saved.
- c) CAL per hour defaults to Total CAL.
- d) A Resumption in exercise in less than 5 minutes will resume Distance/TIME from saved values automatically.

Auto Power Down: Over 5 minutes. All values revert to zero after restart.

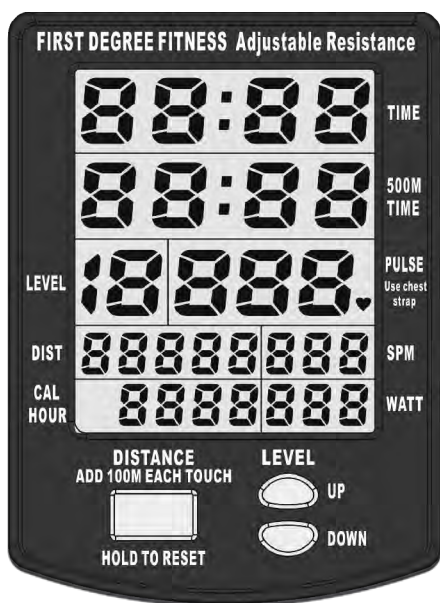

Monitor Instructions:

- **TIME:** Auto start elapsed time.
- **500M TIME:** Time to row 500 meters.
- **PULSE:** Requires optional receiver and chest strap (sold separately).
- **SPM:** Strokes per minute updated each stroke.
- **WATT:** Unit of power updated per rowing stroke.



CAL HOUR: Calories burned per hour at the current Watts. Shows total calories burned when exercise is stopped.

***ALL READINGS UPDATED EVERY 2 SECONDS**

NOTE: Heart Rate Kit and Chest Strap is sold separately.

 WARNING:	<p>Heart Rate monitoring systems may be inaccurate, Over exercising may result in serious injury or death. If you feel faint stop exercising immediately and seek professional medical advice.</p>
--	--

» Detaching the Rower Belt

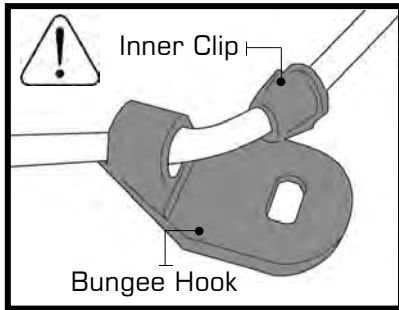

1. To detach Belt, simply pull beyond the range of the normal rowing stroke until the Belt detaches from the Belt Bungee Pulley.

Tip: You'll hear the Velcro separating just before the Belt detaches.

2. Unhook the Bungee Shock Cord from the Rear Brace. Then, push out the Inner Clip from the Bungee Hook. Pull the Bungee through the Inner Clip until free. This will allow for the Bungee Shock Cord to be threaded completely out of the Main Frame and up to the Belt Bungee Pulley where it will be re-attached once the Rower Belt is in the proper position.

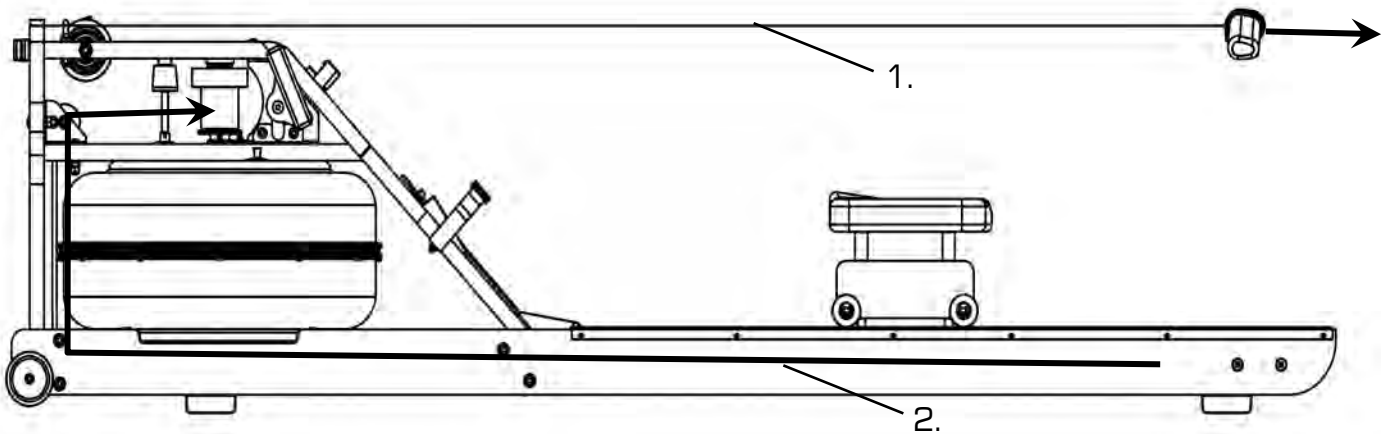

» Reattaching the Rower Belt

STEP 1

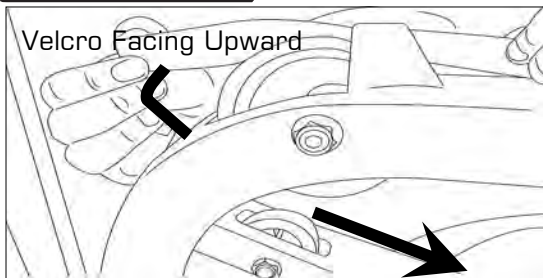

Begin reattaching the Rower Belt by threading around the Rower Belt Pulley with the Velcro side facing upward as illustrated.

STEP 2

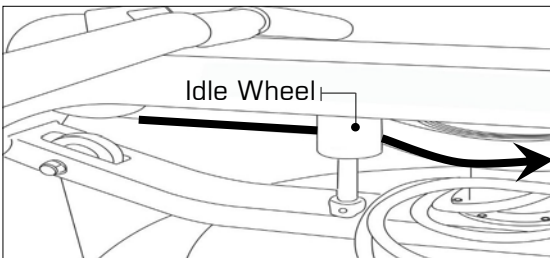

Next, thread the Belt around the Idle Wheel as shown. Once around the Idle Wheel, attach the Rower Belt to the Belt/Bungee Pulley. There is an obvious "lip" at the attachment point.

STEP 3

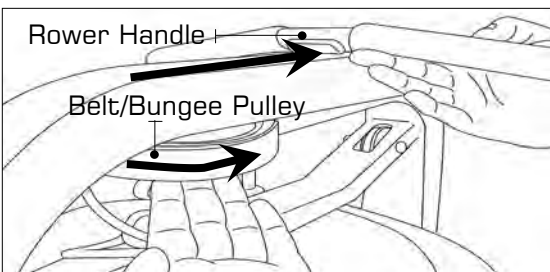

Wind the Rower Belt onto the Belt/Bungee Pulley until the Rower Handle is as it's furthest forward position.

STEP 4

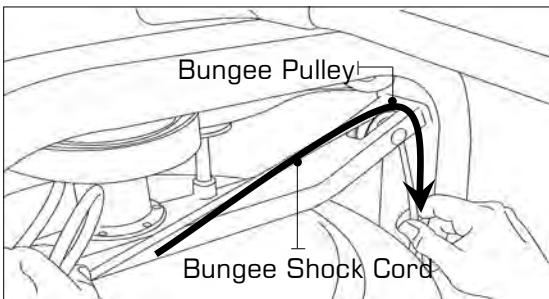

Rethread the Bungee Shock Cord (on opposite side of the Idle Wheel) back through the Bungee Pulleys and tie off at the Attachment Point.

STEP 5

Recoil tension will decrease over time as the Bungee Shock Cord stretches. To increase recoil tension, simply push the Inner Clip out of the Bungee Hook from behind, pull the required amount of bungee through the Inner Clip and replace the Inner Clip into the Bungee Hook as shown below.

Hint: Before reattaching the Inner Clip/Bungee Hook, tie a slip knot under slight tension at the lower bungee pulley. This will keep the bungee under tension while reassembling the Bungee Hook.

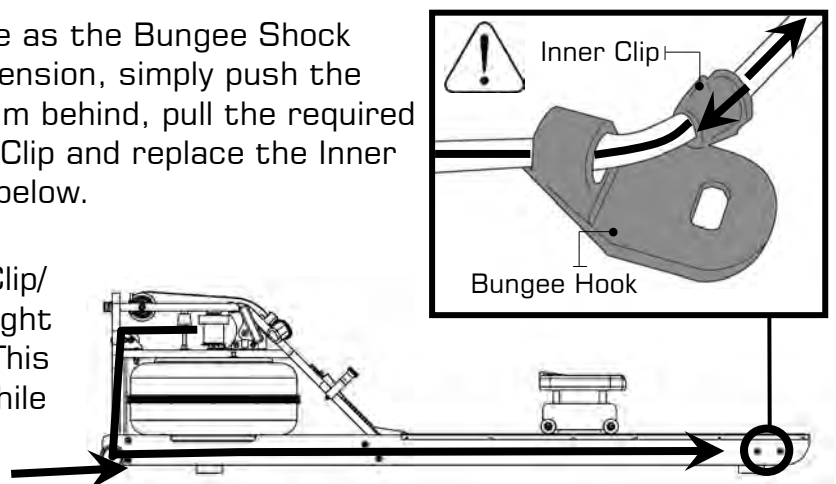

» Maintenance

All preventive maintenance activities must be performed on a regular basis. Performing routine preventive maintenance actions can aid in providing safe, trouble-free operation of all FIRST DEGREE FITNESS equipment.

FIRST DEGREE FITNESS is not responsible for performing regular inspection and maintenance actions for your machines. Instruct all personnel in equipment inspection and maintenance actions and also in accident reporting and recording.



CAUTION Wipe and clean the Tank, Rails, and the Seat Wheels with clean water. Do not use any chemical cleaner.

Item	Time Frame	Instructions	Notes
Seat Rails and Wheels	Weekly	Wipe down Side Rails and Seat Wheels with lint free cloth.	
Frame	Weekly	Wipe down Frame with lint free cloth.	
Tank Shell	Weekly	Only use water and a clean cloth to wipe the Tank Shell. Do NOT use any chemical cleaner to wipe the Tank Shell	
Tank and Water Treatment	12 months to 2 years	Follow instructions as specified in the "Water Treatment Procedure" section of this manual.	
Bungee Cord	Check every hundred hours for correct tension and for signs of wear.	The Bungee Cord should last for many years. If a Bungee Cord change is required, please contact your local service representative or go online at www.firstdegreefitness.com for further details.	
Rowing Belt	Check every hundred hours for correct tension and for signs of wear.	The Rowing Belt should provide many years of trouble free use. If a Rowing Belt change is required, please contact your local service representative or go online at www.firstdegreefitness.com for further details.	

» Troubleshooting

Fault	Probable Cause	Solution
Water changes color or becomes cloudy.	Rower is in direct sunlight or has not had water treatment. Local tap water is of poor quality.	Change Rower location to reduce direct exposure to sunlight. Add water treatment or change tank water as directed in the water treatment section of this manual. Consider using distilled water to refill tank.
Rower Belt slipping off Belt/ Bungee Pulley.	Bungee not under enough tension. Recoil not strong enough	Tighten Bungee Cord following the instructions in "Reattaching the Rower Belt" section of this manual at "Step 5".
Inconsistent readings on the Rower Monitor for 500meter split time and SPM (strokes per minute).	Sensor gap Faulty Sensor Sensor has moved out of position Wiring harness	Use the battery cover of the Monitor as a "Gap Tool" to check the gap between Sensor Head and Magnetic Ring, or see if the Sensor head has moved out of position. Please contact your nearest FDF customer service center for details
The Rower Monitor does not illuminate after battery installation.	Batteries installed incorrectly or need replacing.	Replace/reinstall batteries in correct position and try again. If the LCD screen fails to illuminate, try rotating the batteries slightly in the Monitor. If this fails, contact your local service center.
The Rower Monitor screen illuminates, but does not register when rowing.	Loose or failed connection. Sensor gap too wide	Check that the Monitor lead is connected properly. If it is connected then contact your local service center. Check Sensor gap.

Optional Fixture Kit Instructions

A Fixture Kit for upright storage can be purchased separately.

STEP 1

Install the Z Bracket onto the Storage Base.

Note: Do not tighten the Knob and the Bolt.

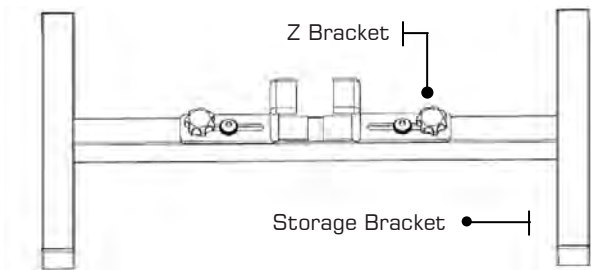

STEP 2

Install the Bracket onto the Rower as shown.

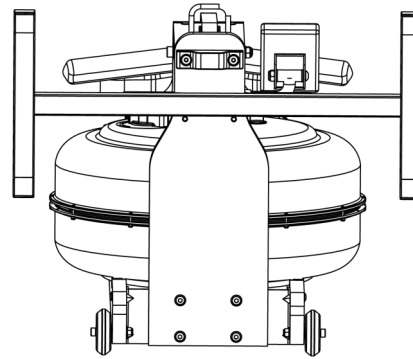

STEP 3

Tighten the Z Bracket Knob to fix to the Rower.

Note: Ensure the Z Bracket is Under the middle crossbar secure

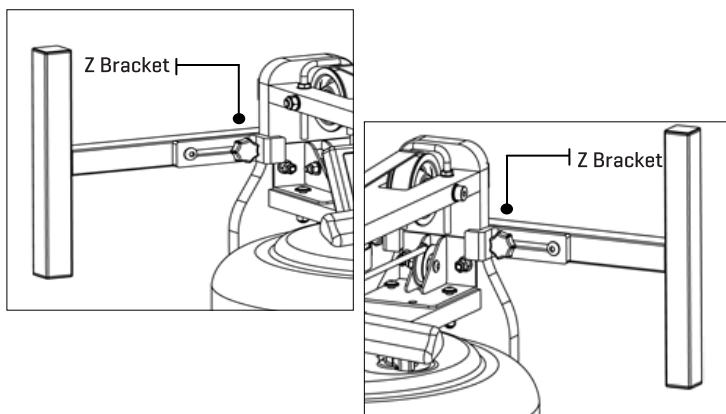

STEP 4

Stand the Rower up vertically with the Main Frame on the floor. Using the 8mm Allen Wrench tighten the Bolts.

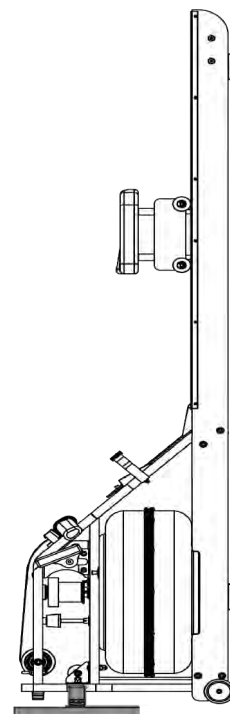

» International Warranty

HOME USE

FIRST DEGREE FITNESS Limited warrants that the **VIKING 2 PLUS (model VK2P)**, purchased from an authorized agent and in its undamaged original packaging, is free from defects in materials and workmanship. FIRST DEGREE FITNESS Limited or its agent will, at their discretion, repair or replace parts that become defective within the warranty period, subject to the specific inclusions and exclusions below.

Main Frame – 5 Year Limited Warranty

FIRST DEGREE FITNESS will repair or replace the Wooden Main Frame of the Rower should it fail due to any defect in materials or workmanship within 5 years of the original purchase. Warranty does not apply to frame coating.

Polycarbonate Tank & Seals – 5 Year Limited Warranty

FIRST DEGREE FITNESS will repair or replace the polycarbonate tank or seals should they fail due to any defect in materials or workmanship within 5 years of the original purchase.

Mechanical Components (of a non-wearing nature) – 2 Year Limited Warranty

FIRST DEGREE FITNESS will repair or replace any mechanical component should it fail due to any defect in materials or workmanship within 2 years of the original purchase.

Specific Inclusions

- Seat Frame
- Seat Rails
- Shaft and Impeller Assembly

All Other Components (of a wearing nature) – 1 Year Limited Warranty

FIRST DEGREE FITNESS will repair or replace any component should it fail due to any defect in materials or workmanship within 1 year of the original purchase.

Specific Inclusions

- Bungee Recoil Cord
- Hand Grips & Footstraps
- Polyester Rowing Belt
- Seat and Seat Runners
- All Pulleys, Rollers & Bearings
- All rubber components
- Monitor & Speed Sensor (excluding replaceable batteries)
- Footplates (pivoting & sliding)

General Exclusions

- Damage to the finish of any part of the machine
- Damage due to neglect, abuse, incorrect assembly or use of the machine
- Any charges for freight or customs clearance associated with the return or dispatch of parts
- Any damage to or loss of goods during transport of any kind
- Any labour cost associated with a warranty claim

General Conditions

- The serial number of the machine must be correctly registered with FIRST DEGREE FITNESS Limited or one of its appointed distributors
- FIRST DEGREE FITNESS Limited reserve the right to examine any part where replacement is claimed under warranty
- Warranty period applies only to the original purchaser from the date of purchase and is not transferable
- The product must be returned to your place of purchase in original packaging with transportation, insurance and associated charges paid for by you and risk of loss or damage assumed by you
- FIRST DEGREE FITNESS makes no other warranties except as stated here and expressly disclaims all warranties not stated in this warranty. Neither First Degree Fitness nor its associates shall be responsible for incidental or consequential damages
- Manufacturer's warranty automatically commences upon sale of the product to end user or upon the expiration of one (1) year from month of manufacture, whichever occurs first



FIRST DEGREE FITNESS
Fluid INNOVATION

FITNESS PRODUCTS INSPIRED BY REAL LIFE

WWW.FIRSTDEGREEFITNESS.COM

CONTACT US

For customer support please visit
firstdegreefitness.com/support

TAIWAN

T: +886 3 478 3306
764 Chung Shan South Rd
Yangmei Taoyuan
Taiwan R.O.C.

