

CABLE COLUMN ASSEMBLY GUIDE

VERSION: XCC-103

PART #: 5682201-B

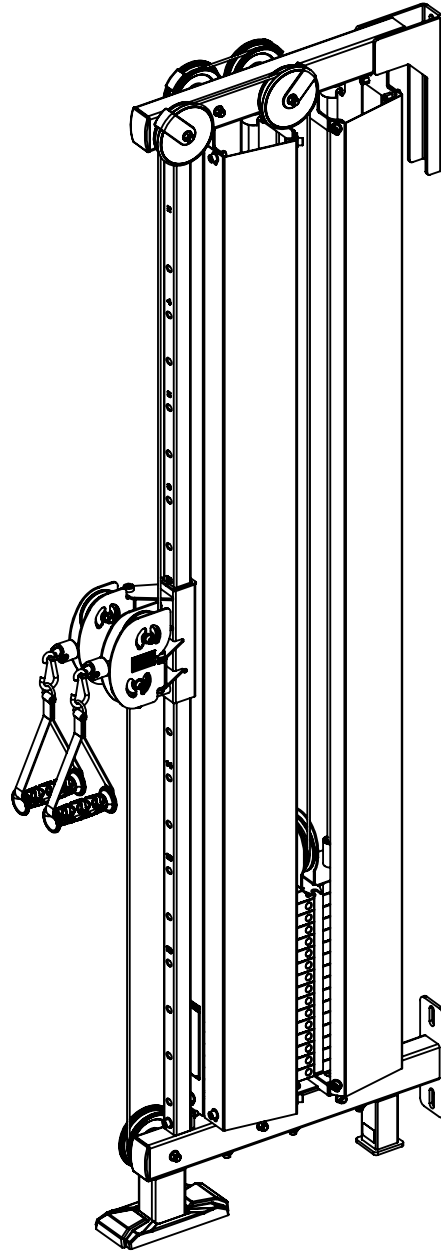

TORQUE USA

ITEM	PART NUMBER	DESCRIPTION	QTY
1	56373PA	PTD ASSY, BASE	1
2	5479401	BOOT, X-RACK	1
3	2001301	WASHER, FLAT 1/2 SAE ST ZN	14
4	2005814	BOLT, 1/2-13 X 3-3/4" (95mm) SOCKET HEAD	6
5	2001401	NUT, 1/2-13 LK ST ZN	7
6	5501001	SPACER, 13ID X 25OD X 6MM	3
7	2005804	BOLT, 1/2-13 X 1-1/4" (32mm) SOCKET HEAD	4
8	2005816	BOLT, 1/2-13 X 4-1/4" (108mm) SOCKET HEAD	4
9	5638401	TUBE, CARRIAGE UPRIGHT	1
10	5499101	ASSY, CARRIAGE	1
11	2001101	WASHER, FLAT 3/8 SAE ST ZN	24
12	2008409	BOLT, 3/8-16 X 2-1/2" (64mm) ST HT SOCKET HEAD	4
13	2001201	NUT, 3/8-16 LK ST ZN	4
14	56394PA	PTD ASSY, BASE SHROUD SUPPORT	1
15	2005815	BOLT, 1/2-13 X 4" (102mm) SOCKET HEAD	5
16	5638201	GUIDE ROD, 19 DIA X 2174	2
17	2005001	WASHER, 2" OD X 13/16" ID X 4MM	2
18	5513601	CUSHION, WEIGHT STACK	2

ITEM	PART NUMBER	DESCRIPTION	QTY
19	56350PA	PTD ASSY, 15 LB WEIGHT PLATE	5
20	56349PA	PTD ASSY, 10 LB WEIGHT PLATE	10
21	56416PA	PTD ASSY, HEAD PLATE	1
22	5095301	SHAFT COLLAR, GUIDE ROD	2
23	5667301	BUSHING, GUIDE ROD RETAINER	2
24	56385PA	PTD ASSY, TOP BOOM	1
25	5500701	LABEL, WEIGHT STACK 1-20	2
26	5639201	CABLE ASSY, XCC-103	1
27	5508801	HOUSING, CABLE COUPLER	2
28	5508901	GROMMET, RUBBER CABLE	2
29	5509001	CORE, CABLE COUPLER	2
30	2003201	CAP SCREW, M5 X 0.8 X 6MM SOCKET HEAD	4
31	56420PA	PTD ASSY, RIGHT FRONT SHROUD	1
32	2009402	BOLT, 3/8-16 X 3/4" (19mm) ST HT SOCKET HEAD W/NP	16
33	56421PA	PTD ASSY, LEFT FRONT SHROUD	1
34	5639301	SHROUD, XCC-103	2
35	5091801	SNAP HOOK, 8MM DIA X 80MM	2
36	5324701-A	ASSY, SHORT STRAP HANDLE	2

NOTE:

- The X-SERIES CABLE COMPONENT attaches to many different Torque Systems. Please identify the system that most closely matches yours on pages 3 - 8 (WALL MOUNT on page 9) and assemble as shown.
- Once that step is complete, proceed to steps 2-5 starting on page 10 and assemble those steps in order.
- After those steps have been completed, please identify the system that most closely matches yours on pages 14-19 (WALL MOUNT on page 20) and assemble accordingly.
- Once that step has is complete, proceed to steps 7-15 starting on page 21 to complete the rest of the assembly.

NOTICE:

Visit: <http://www.torquefitness.com/assembly-manuals/> to download the most current versions of assembly manuals. Some X-Series Packages have dedicated manuals that provide more detailed instructions than this manual.

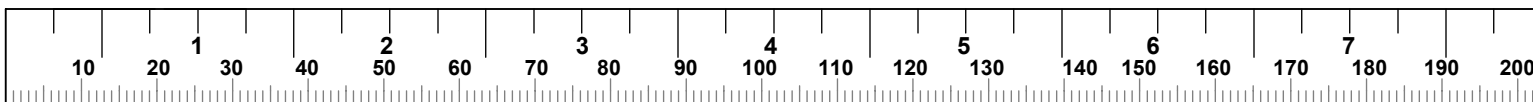

STEP 1a

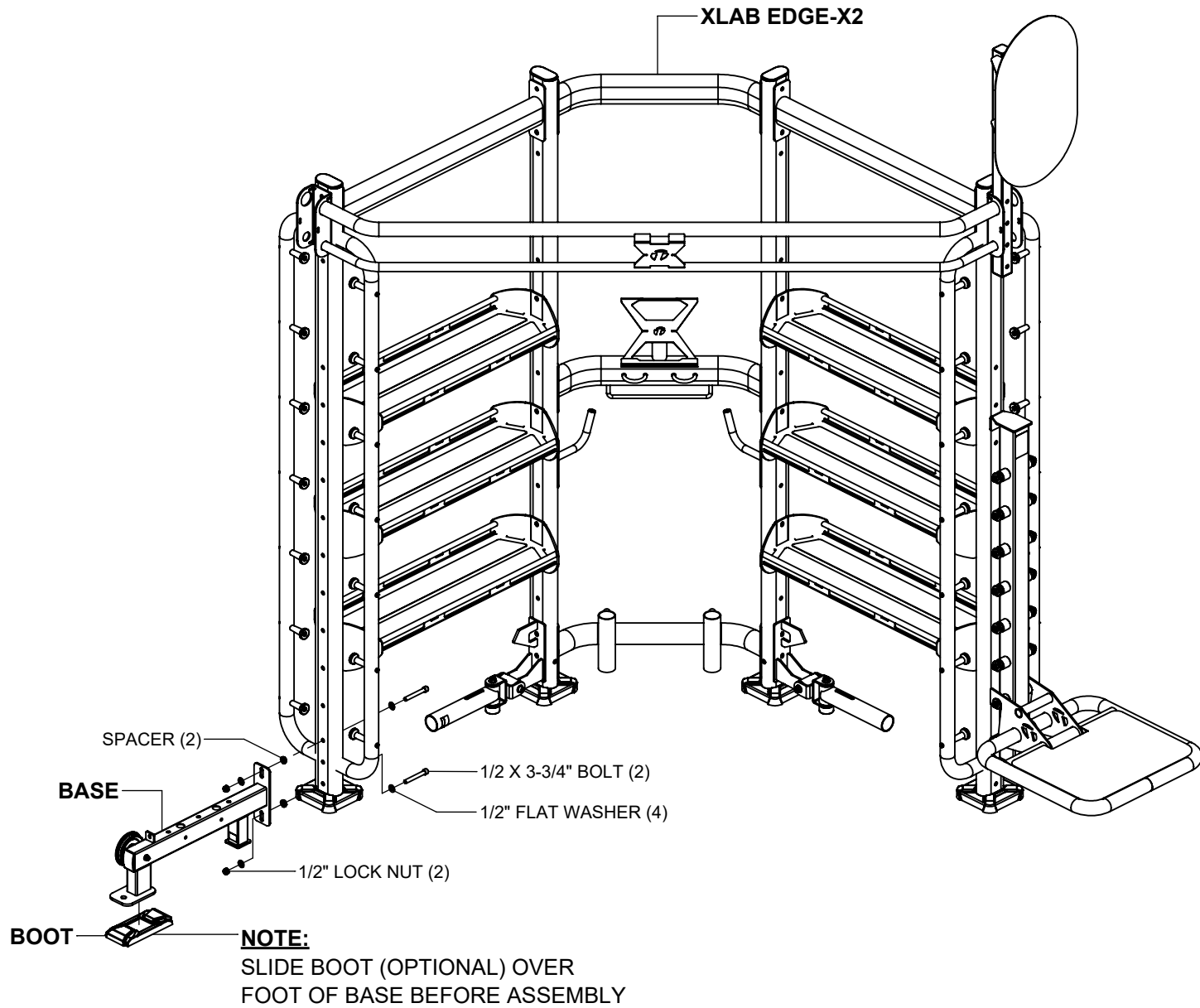

NOTE:

SECURELY tighten all bolt connections in this step.

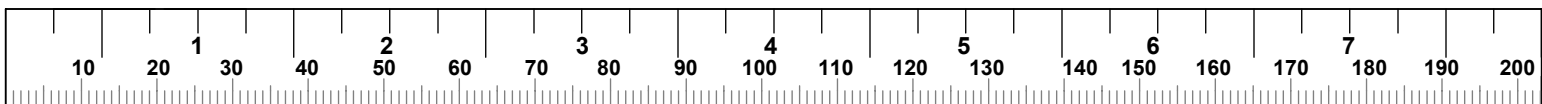

STEP 1b

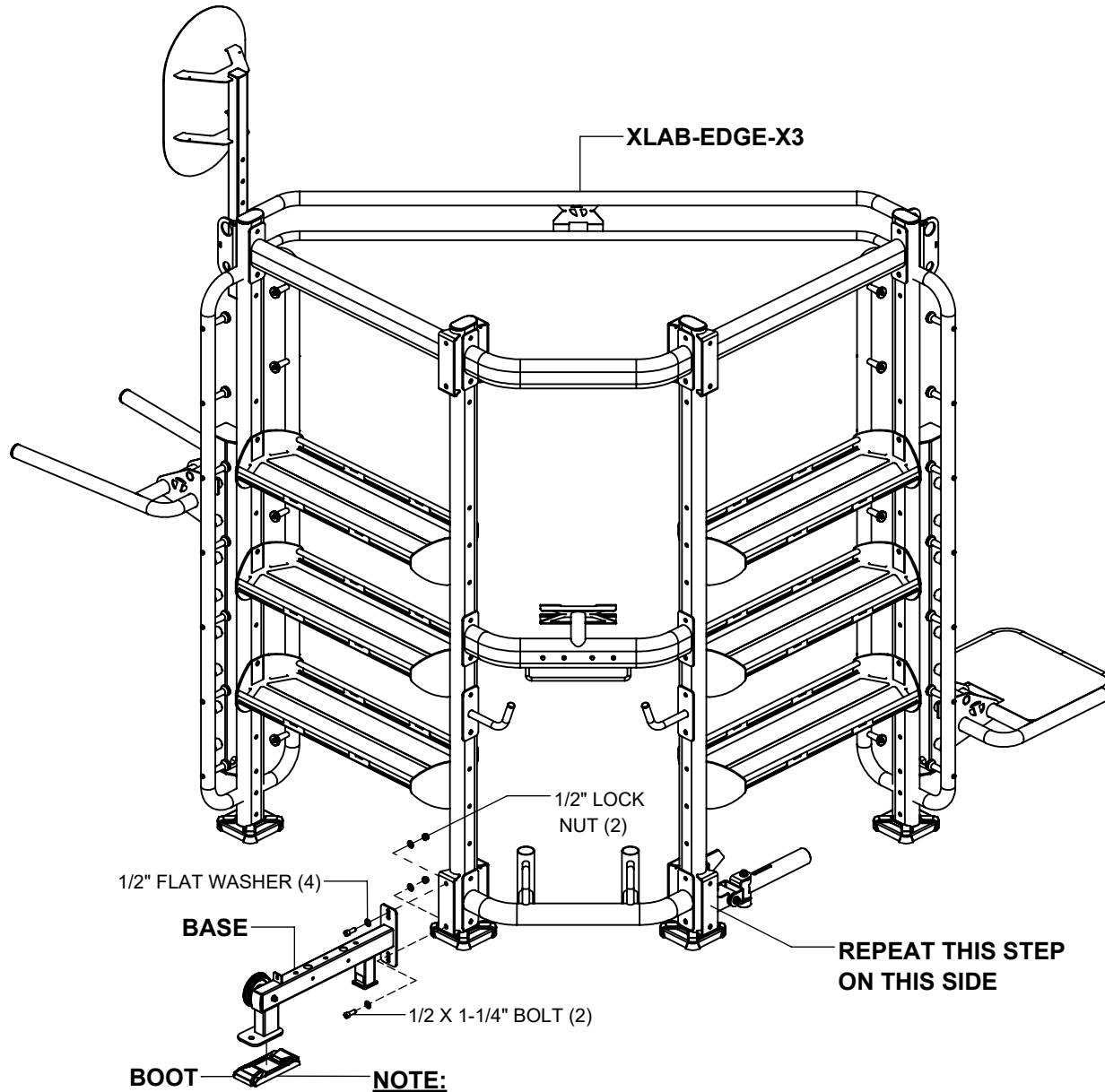

NOTE:

SECURELY tighten all bolt connections in this step.

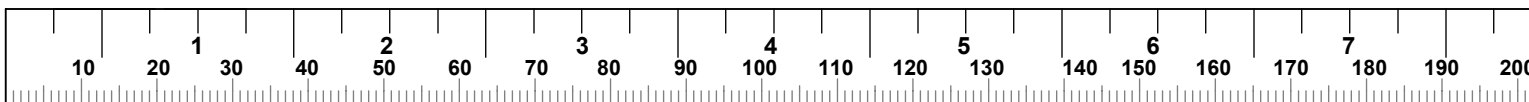

STEP 1c

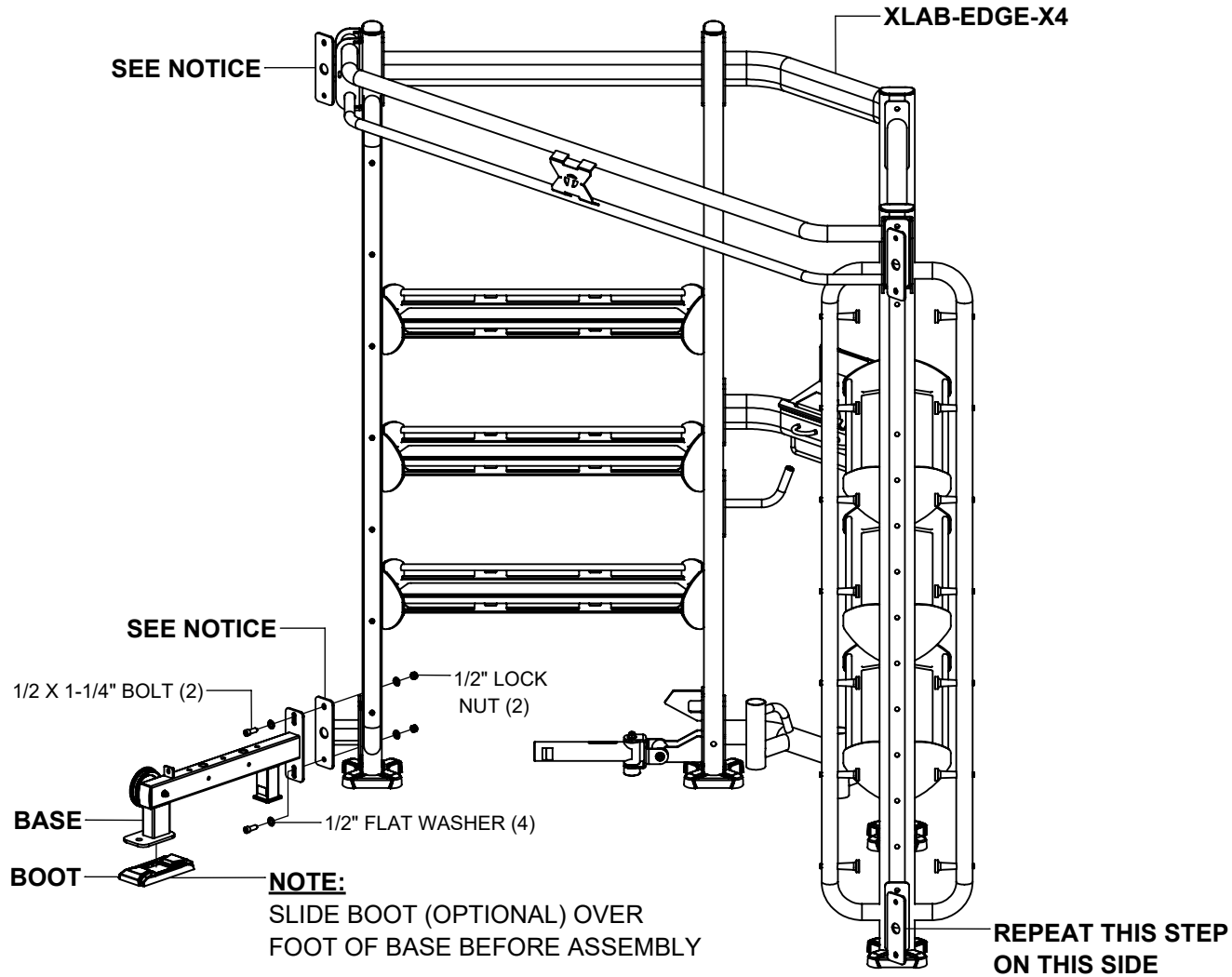

NOTICE:

The X-Lab Edge X4 package (and some custom packages) require angled connectors that bolt to the uprights first. Please download the XLE-X4 instructions from: <http://www.torquefitness.com/assembly-manuals/> for more detailed instructions.

SECURELY tighten all bolt connections in this step.

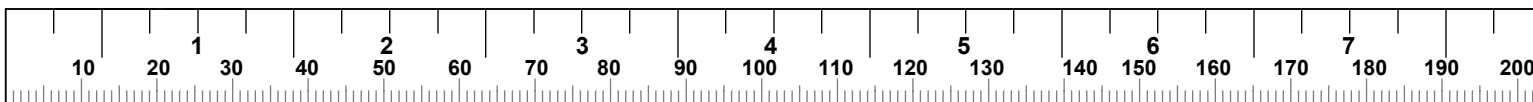

STEP 1d

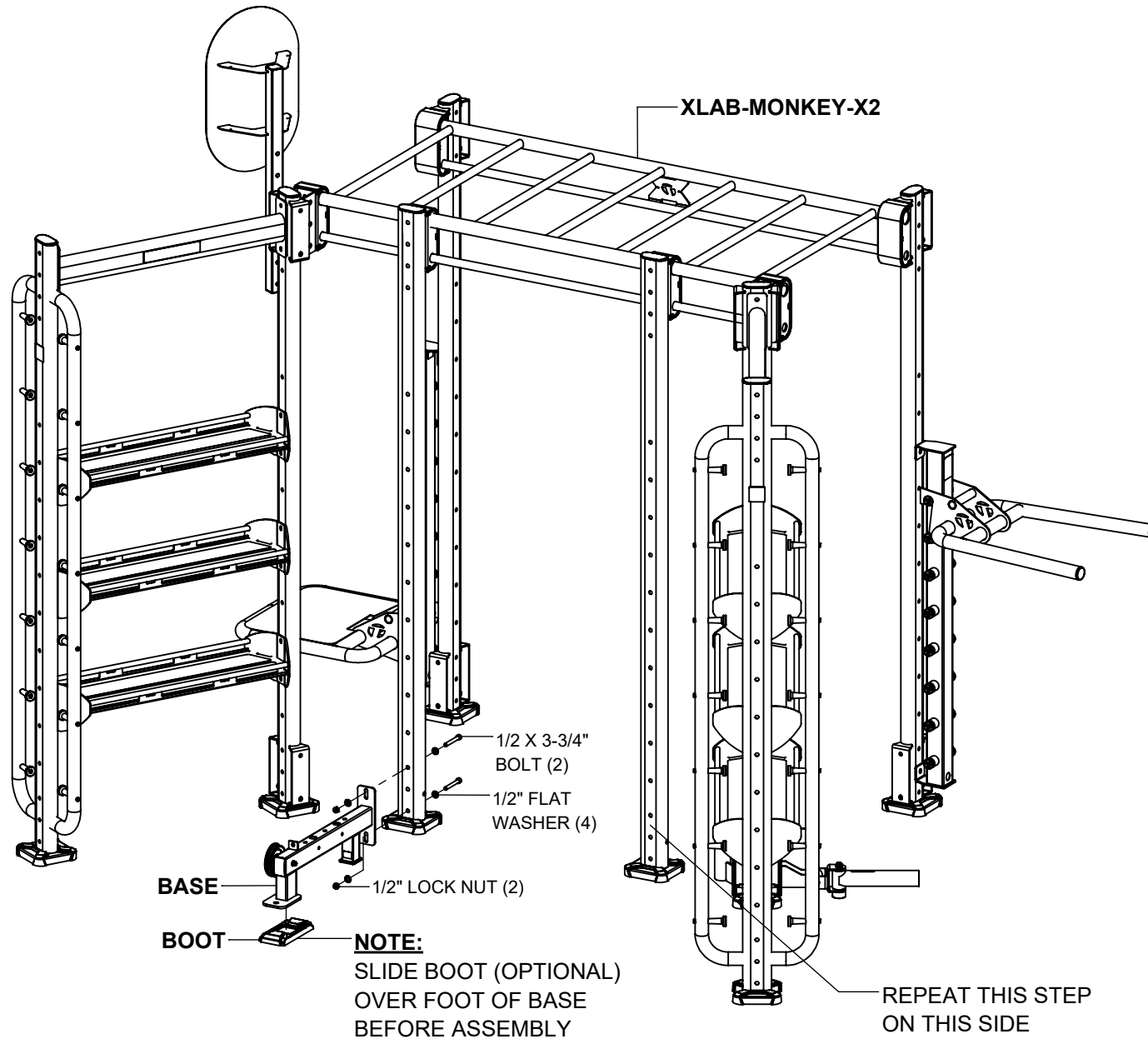

NOTE:

SECURELY tighten all bolt connections in this step.

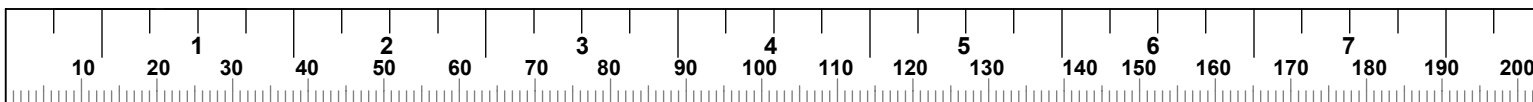

STEP 1e

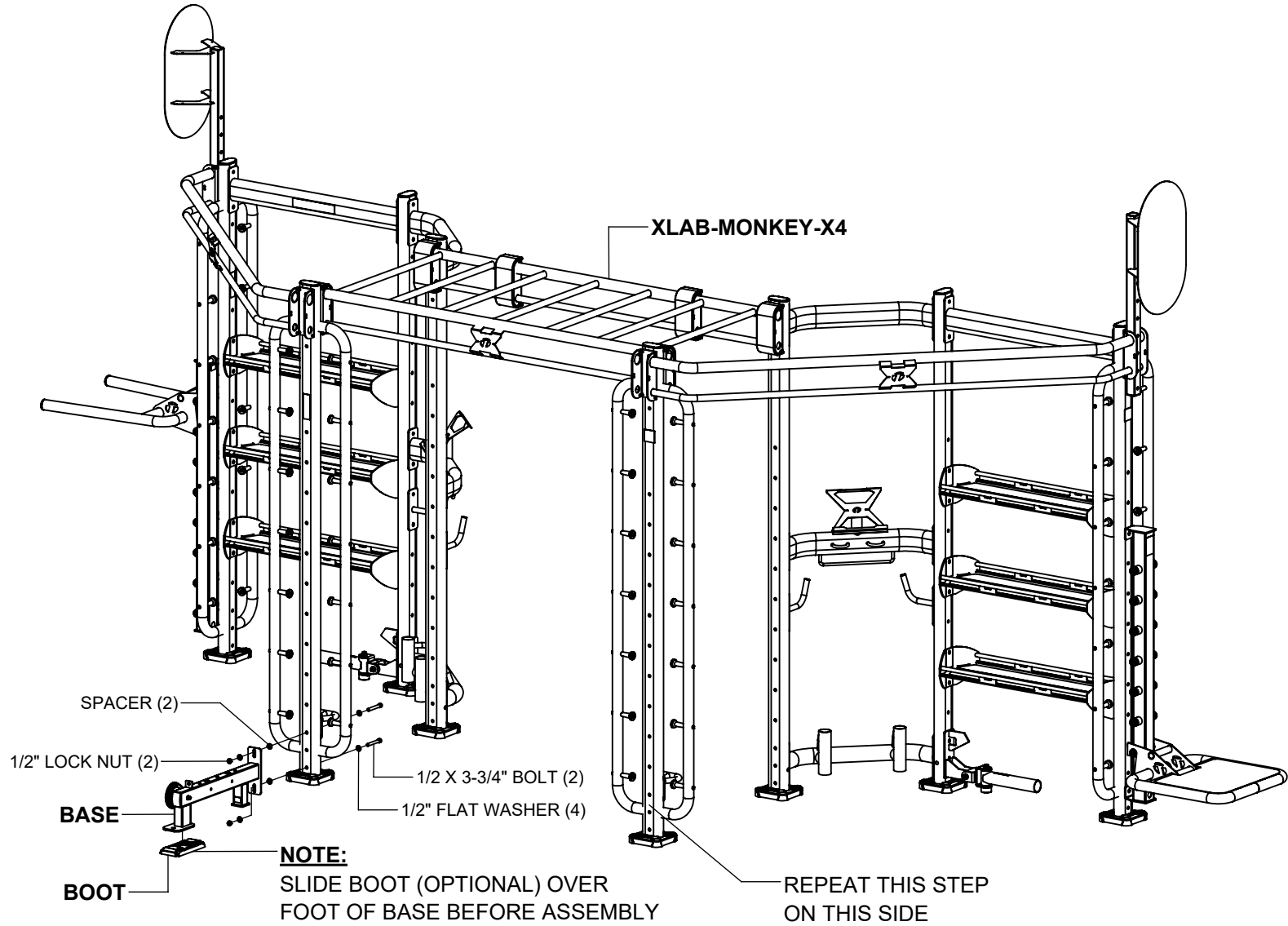

NOTE:

SECURELY tighten all bolt connections in this step.

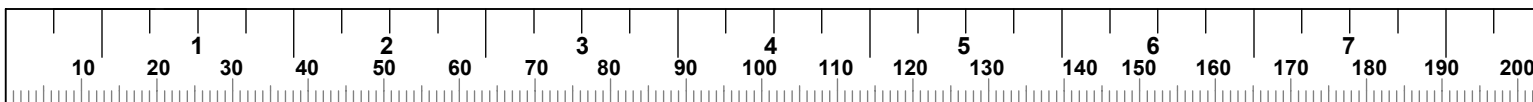

STEP 1f

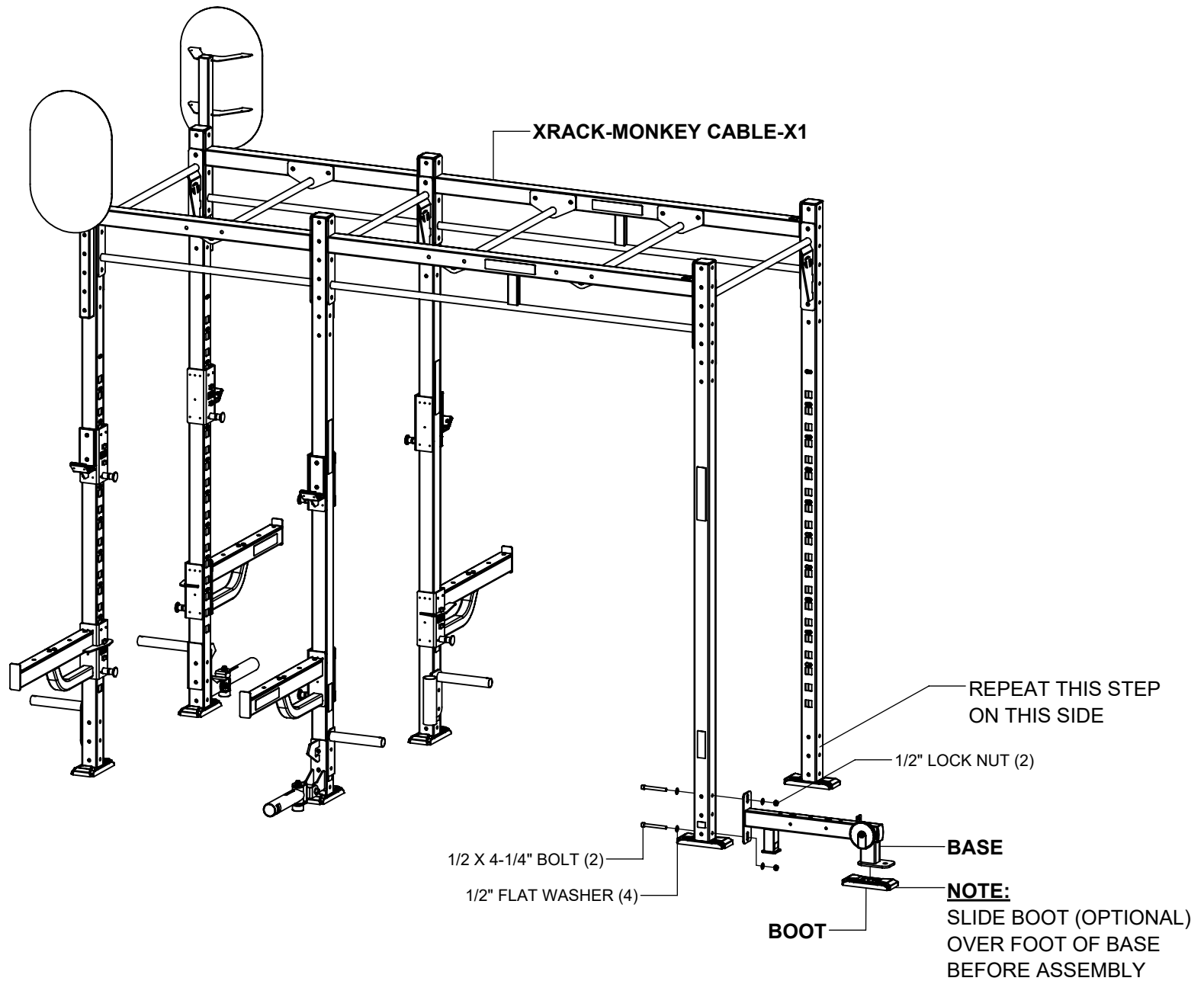

NOTE:

SECURELY tighten all bolt connections in this step.

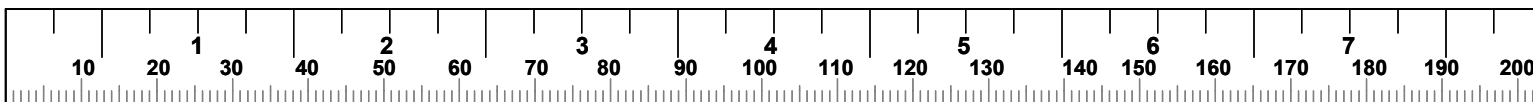

STEP 1g (WALL MOUNT)

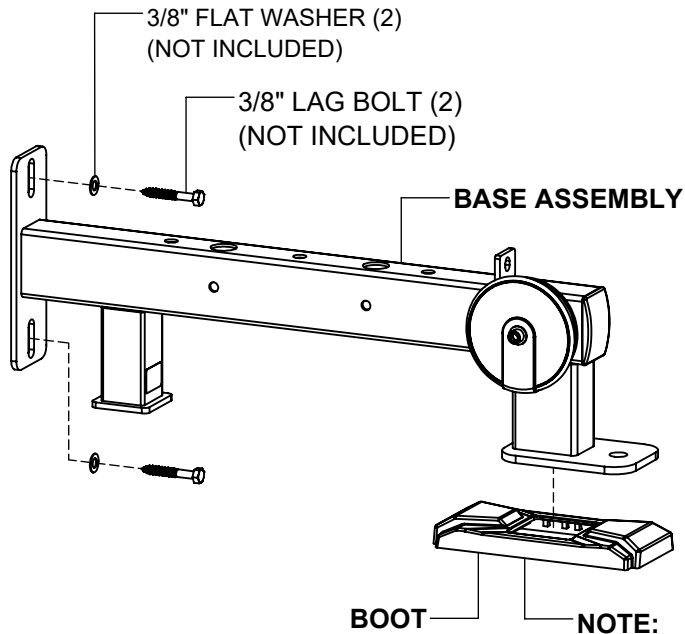

BOOT — **NOTE:**
SLIDE BOOT (OPTIONAL)
OVER FOOT OF BASE
BEFORE ASSEMBLY

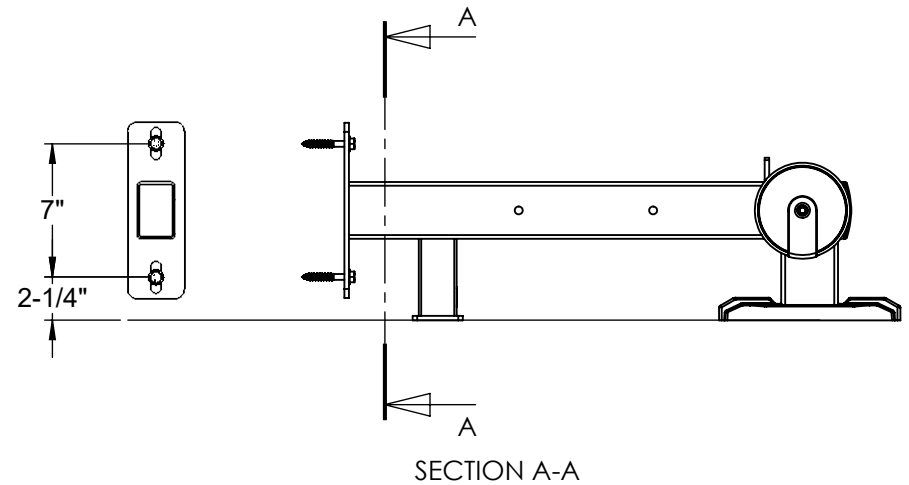

WARNING:
THE BASE ASSEMBLY MUST BE ANCHORED TO
THE WALL USING TWO WALL ANCHORS SUITABLE
FOR THAT PARTICULAR WALL CONSTRUCTION.

NOTES:

The images above show the anchoring hardware used for attaching the BASE ASSEMBLY to a typical wall with wood studs. The anchors used will depend on the wall construction. **NOTE: All anchoring locations must be used.** The pull-out strength of the anchoring bolts used must be equal to or greater than 200 lbs. (91 kg)

SECURELY tighten all bolt connections in this step.

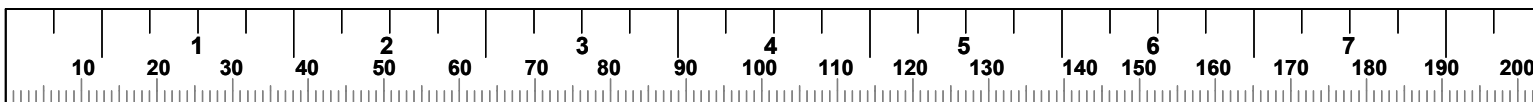

STEP 2

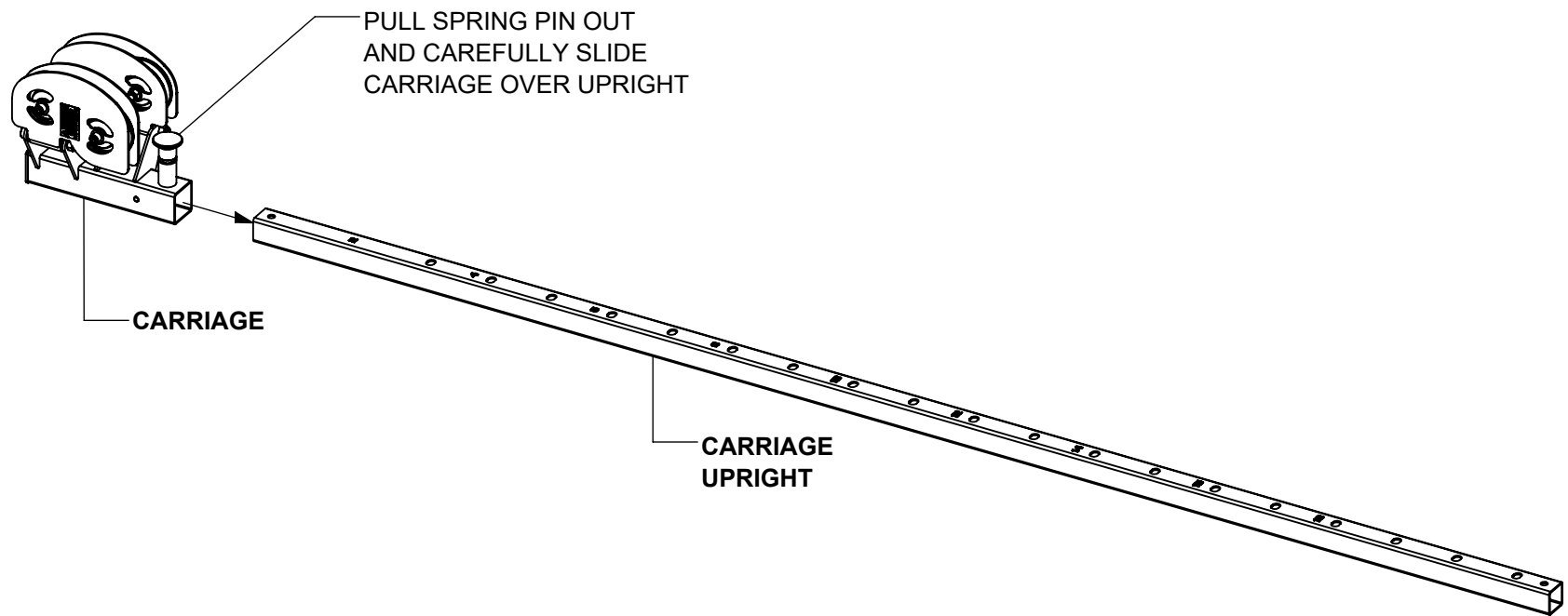

STEP 3

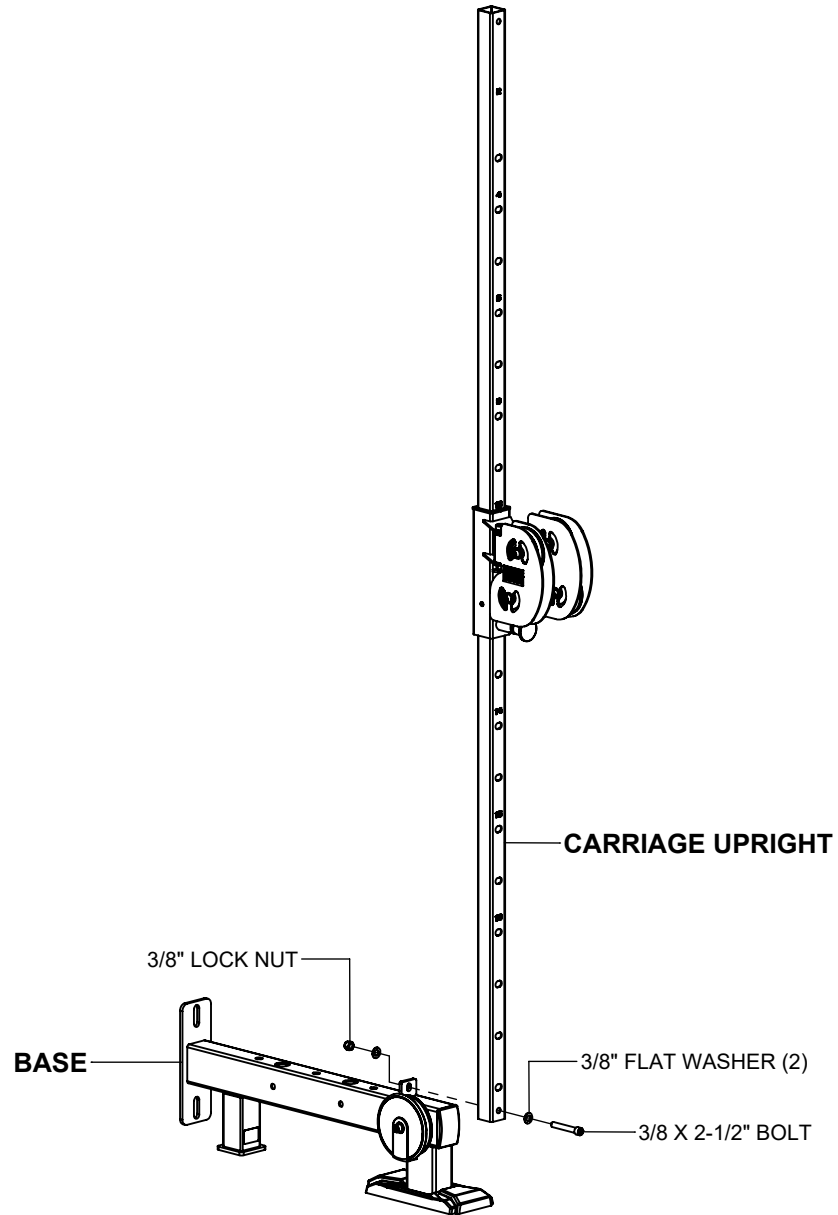

NOTE:

SECURELY assemble all bolt connections in this step.

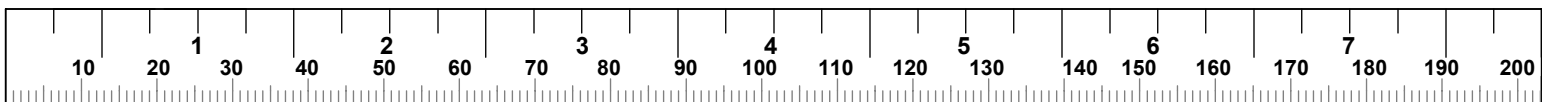

STEP 4

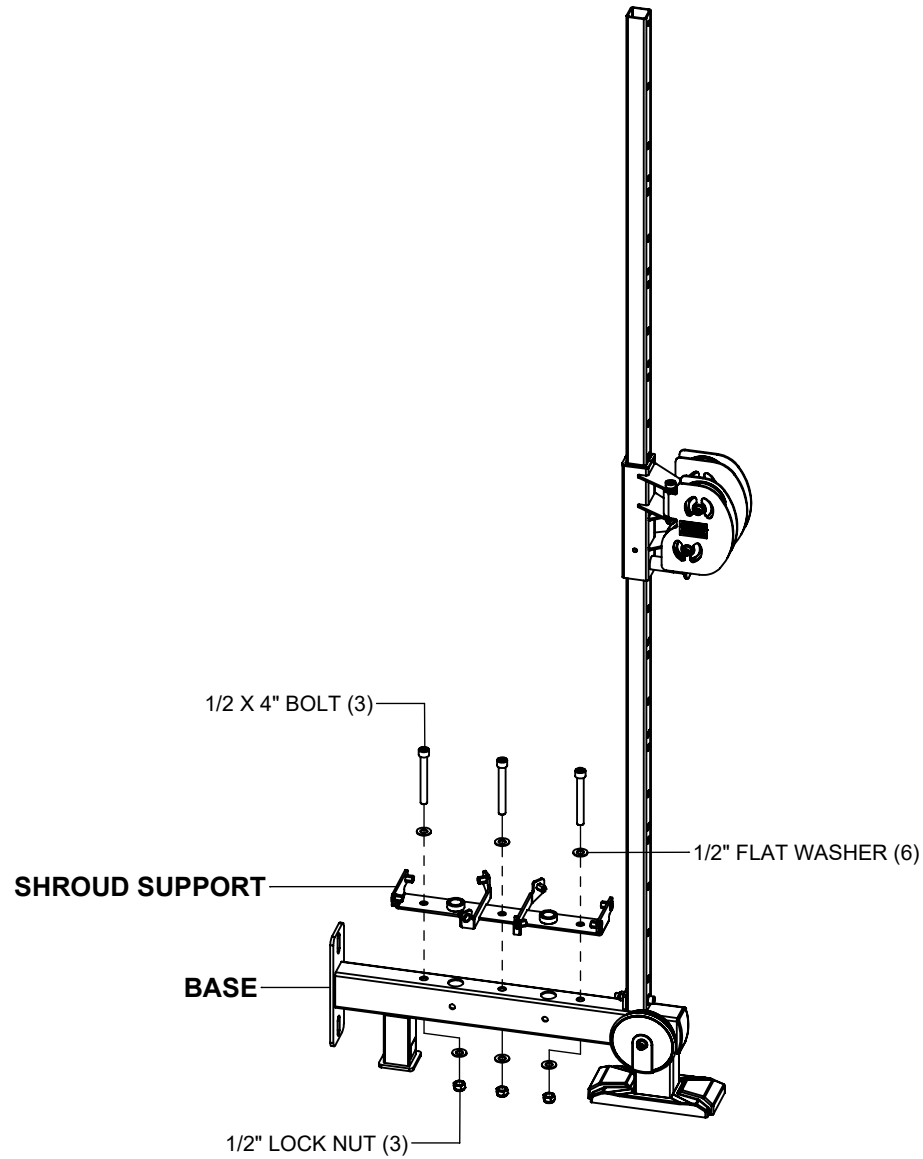

NOTE:

SECURELY assemble all bolt connections in this step.

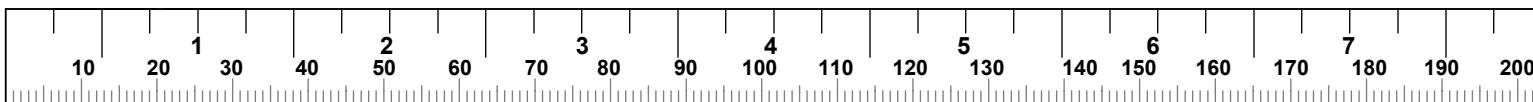

STEP 5

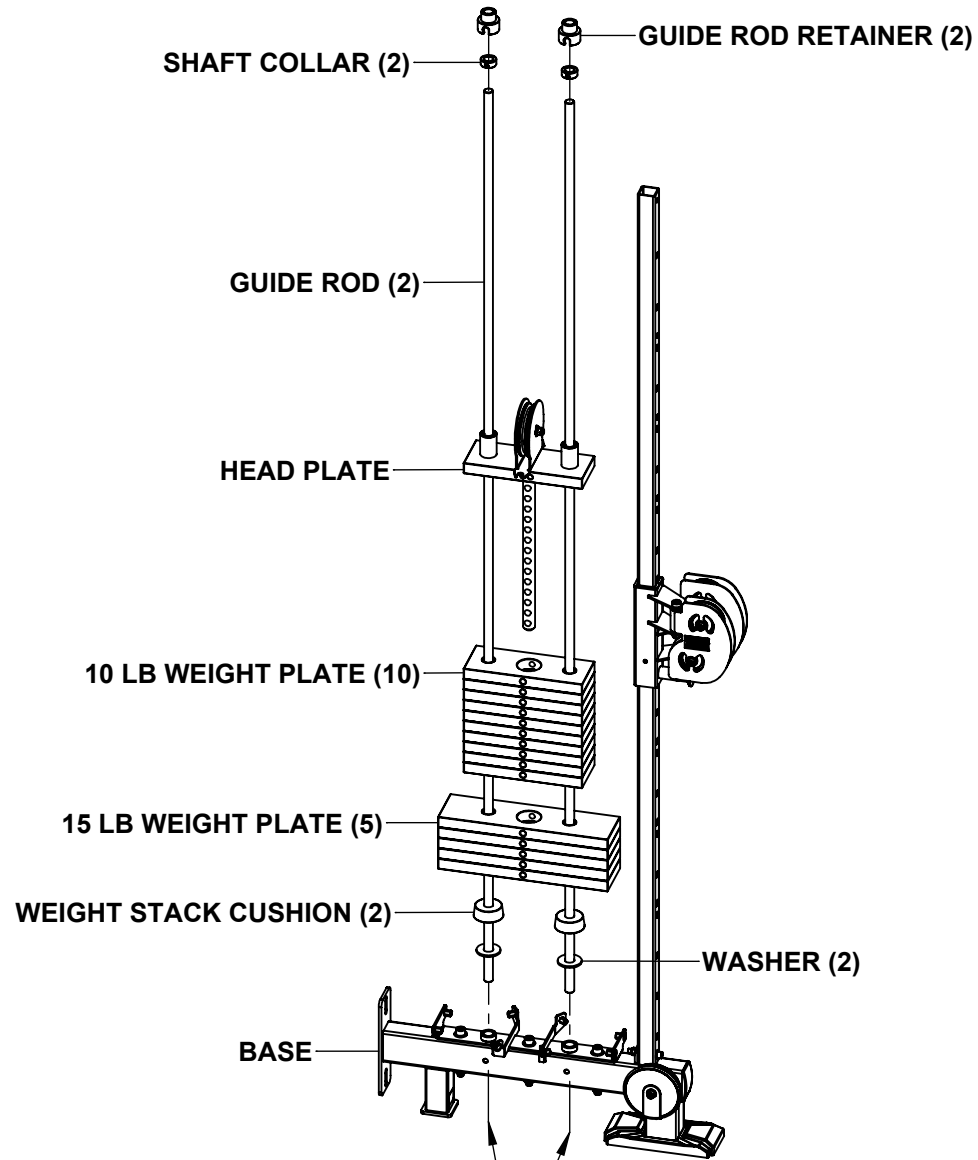

NOTICE:
INSTALL GUIDE RODS THROUGH
THE BASE AND TOUCH THE FLOOR

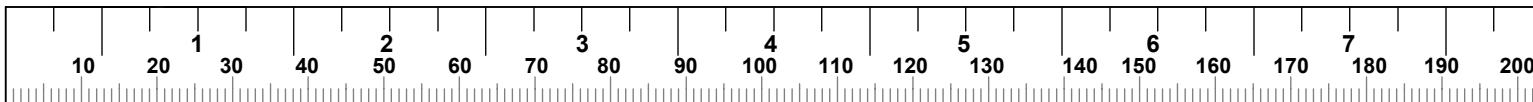

STEP 6a

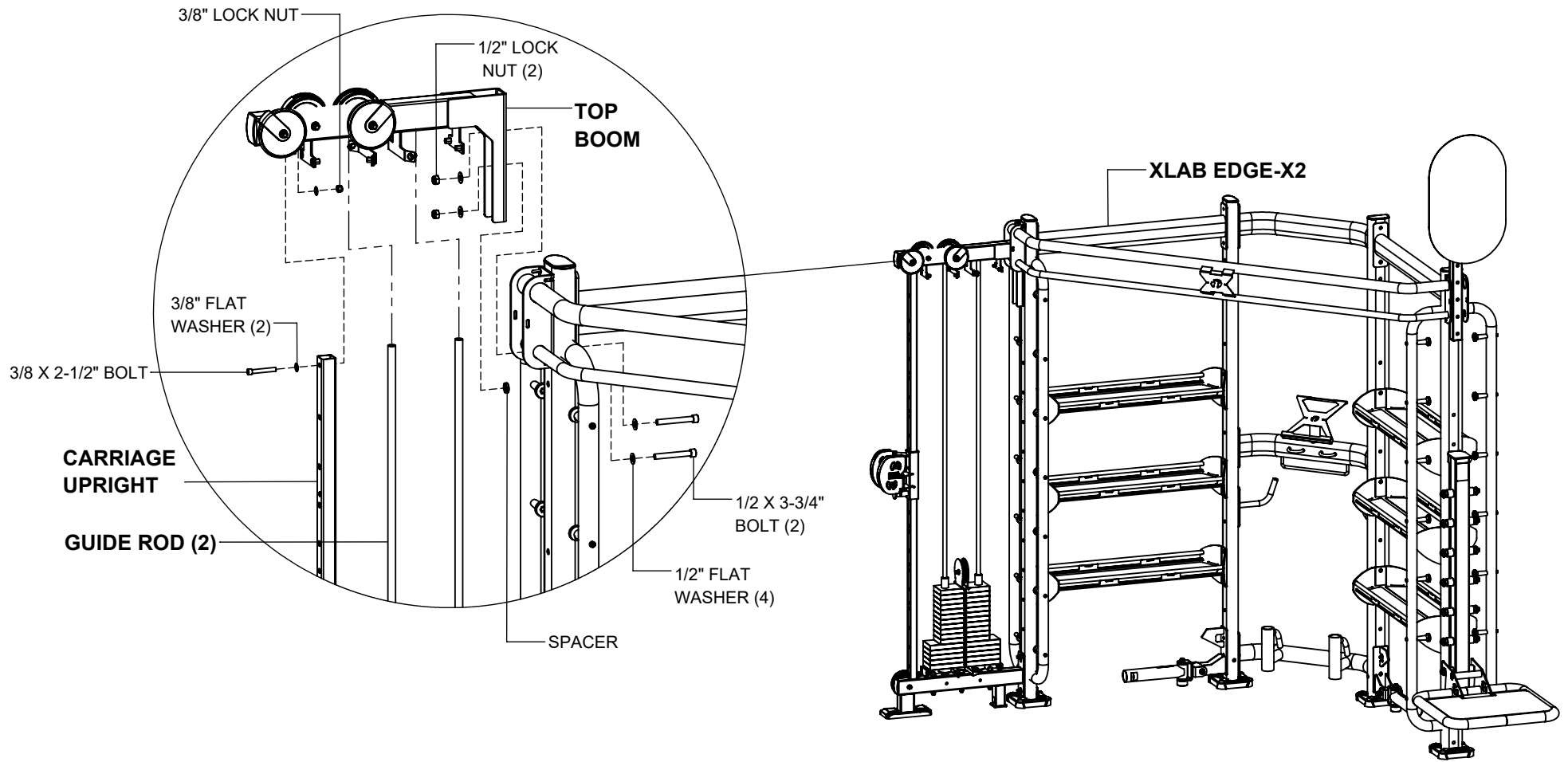

NOTE:

SECURELY assemble all bolt connections in this step.

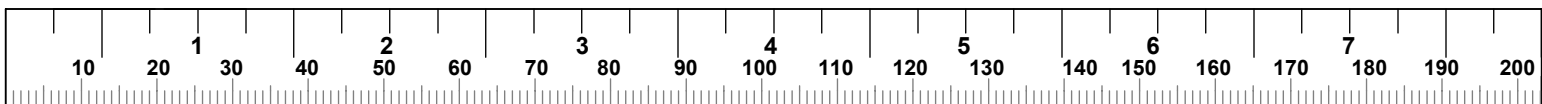

STEP 6b

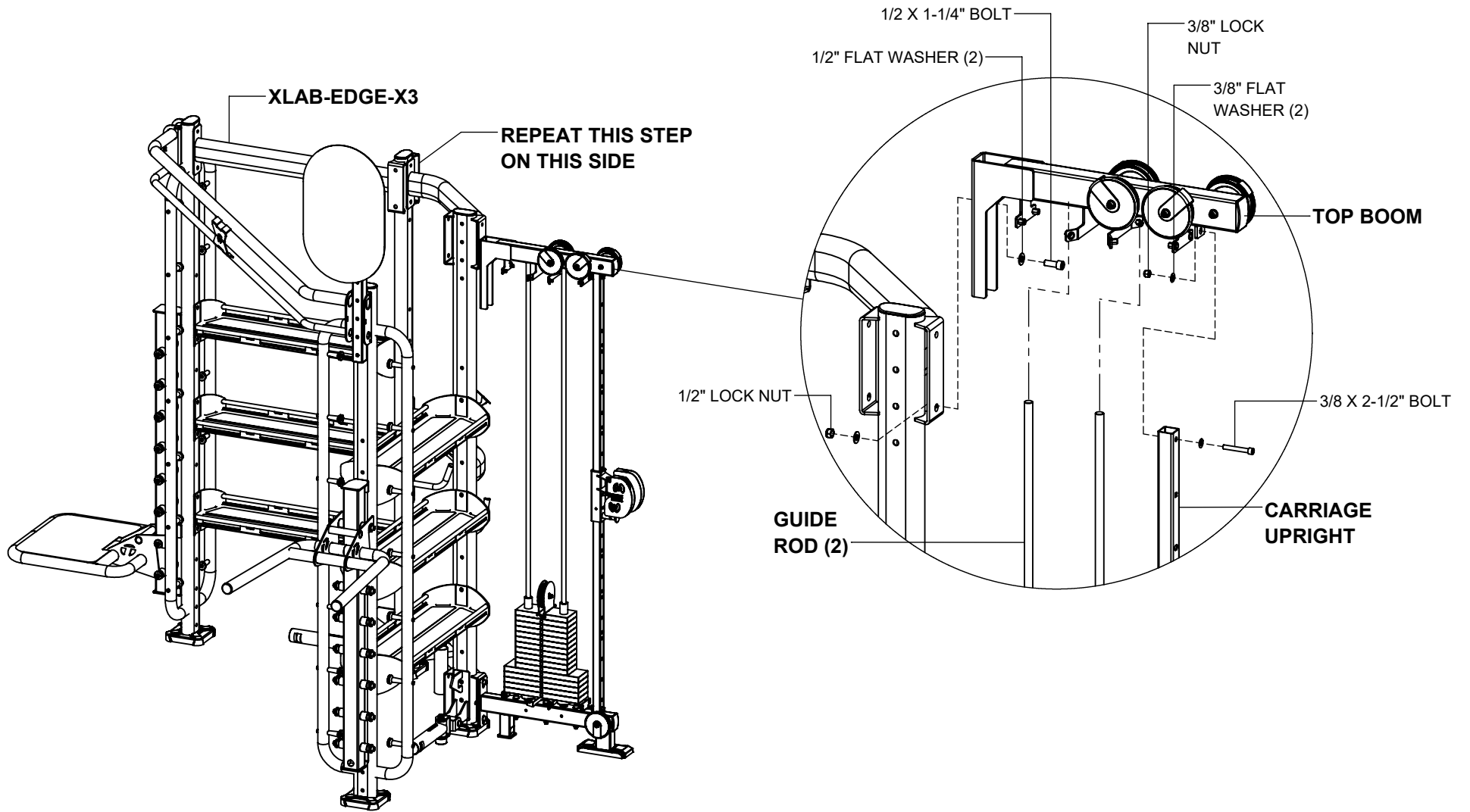

NOTE:

SECURELY assemble all bolt connections in this step.

Some items have been hidden for assembly clarity.

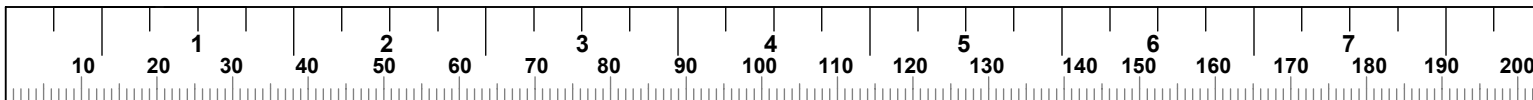

STEP 6c

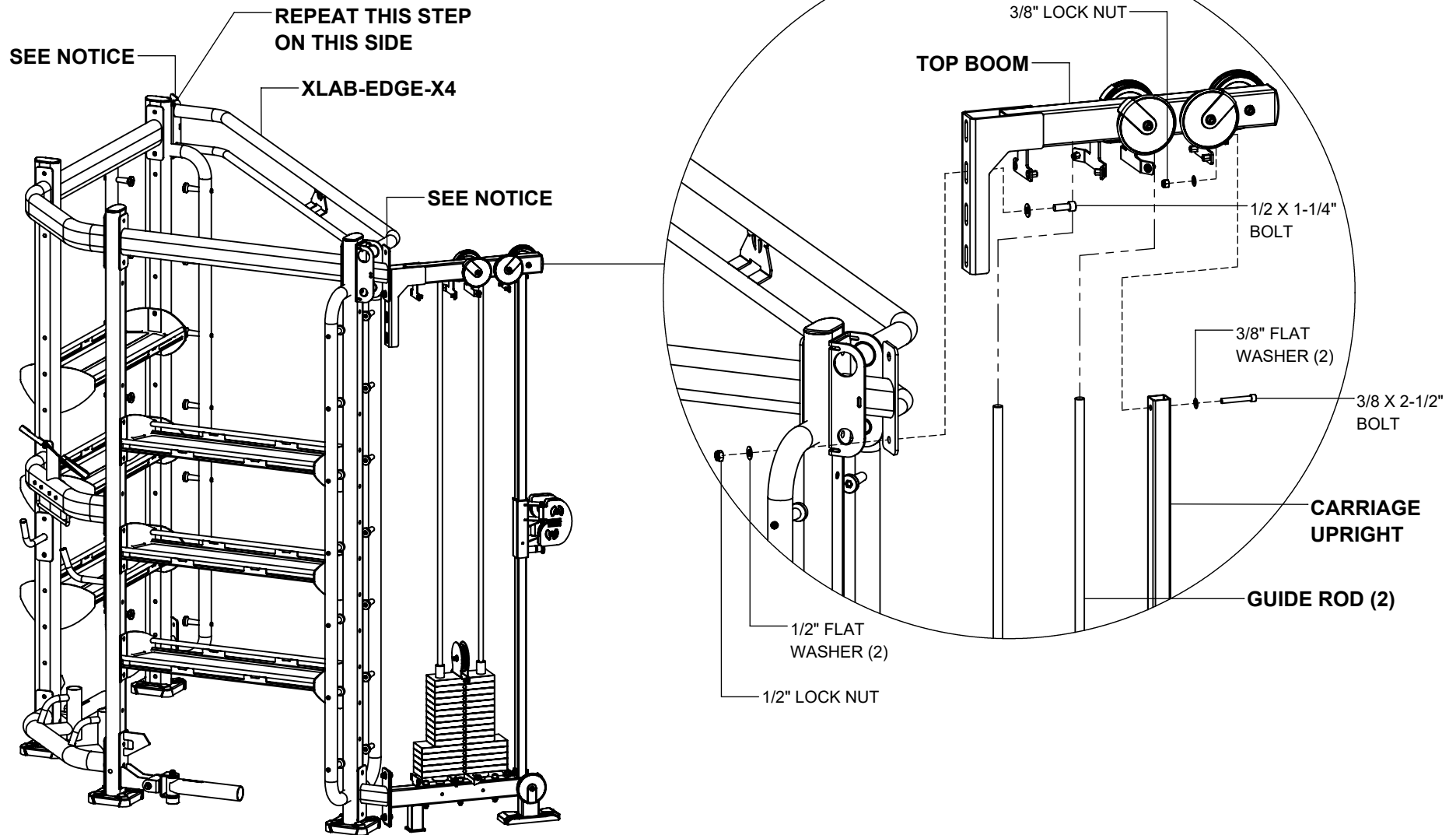

NOTICE:

The X-Lab Edge X4 package (and some custom packages) require angled connectors that bolt to the uprights first. Please download the XLE-X4 instructions from: <http://www.torquefitness.com/assembly-manuals/> for more detailed instructions.

SECURELY assemble all bolt connections in this step.

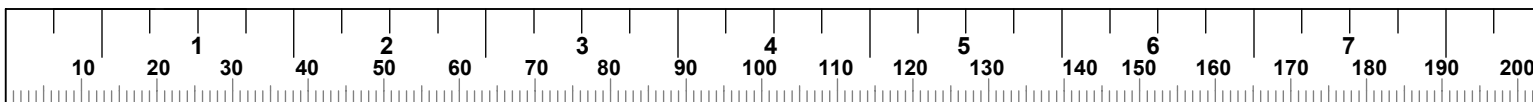

STEP 6d

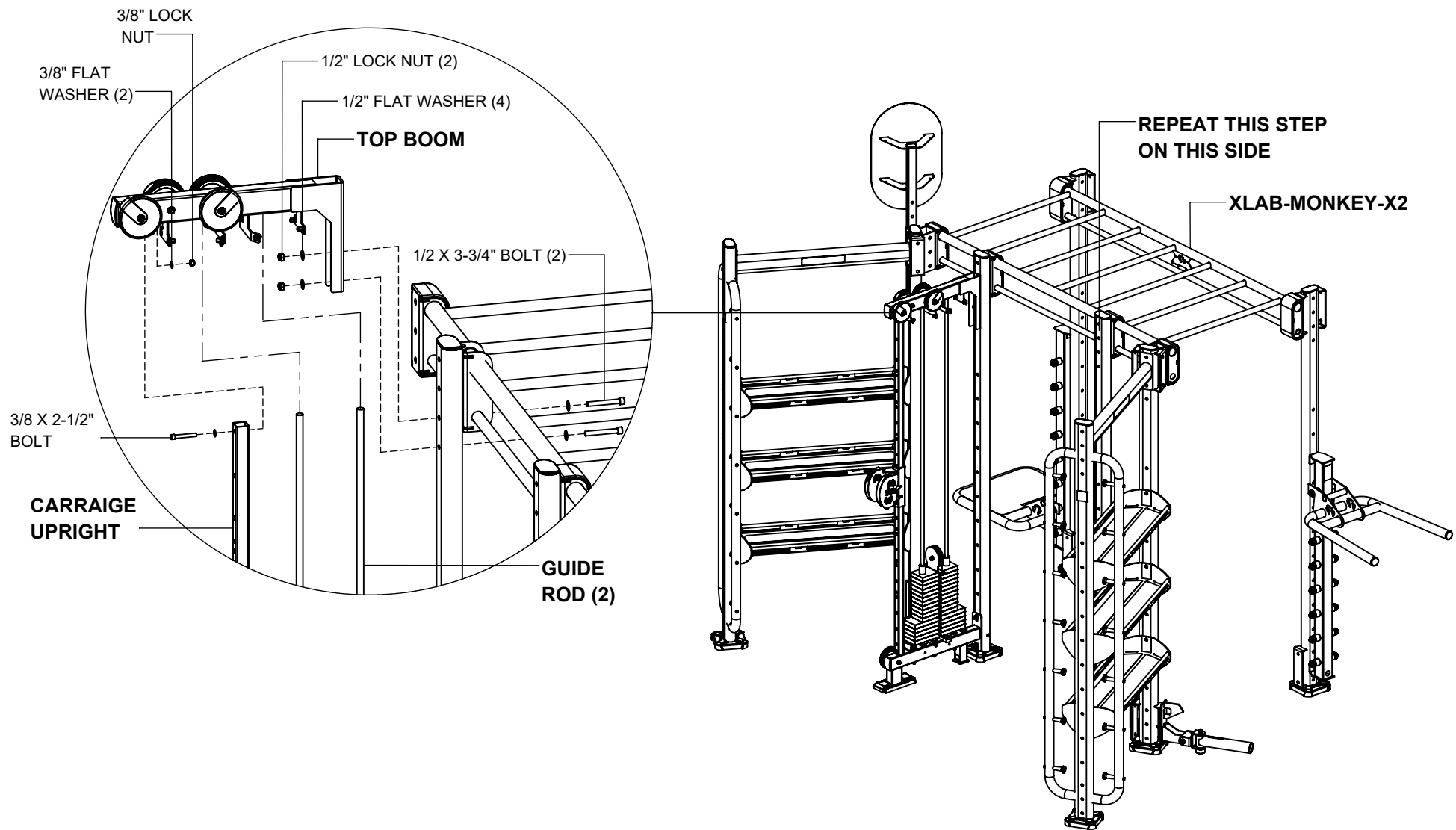

NOTE:

SECURELY assemble all bolt connections in this step.

Some items have been hidden for assembly clarity.

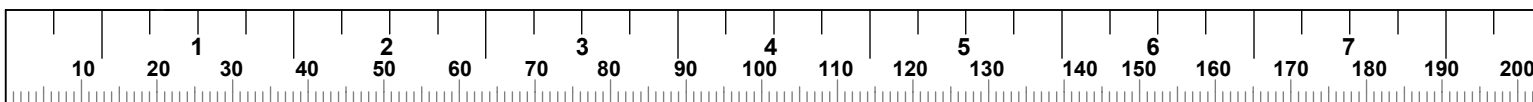

STEP 6e

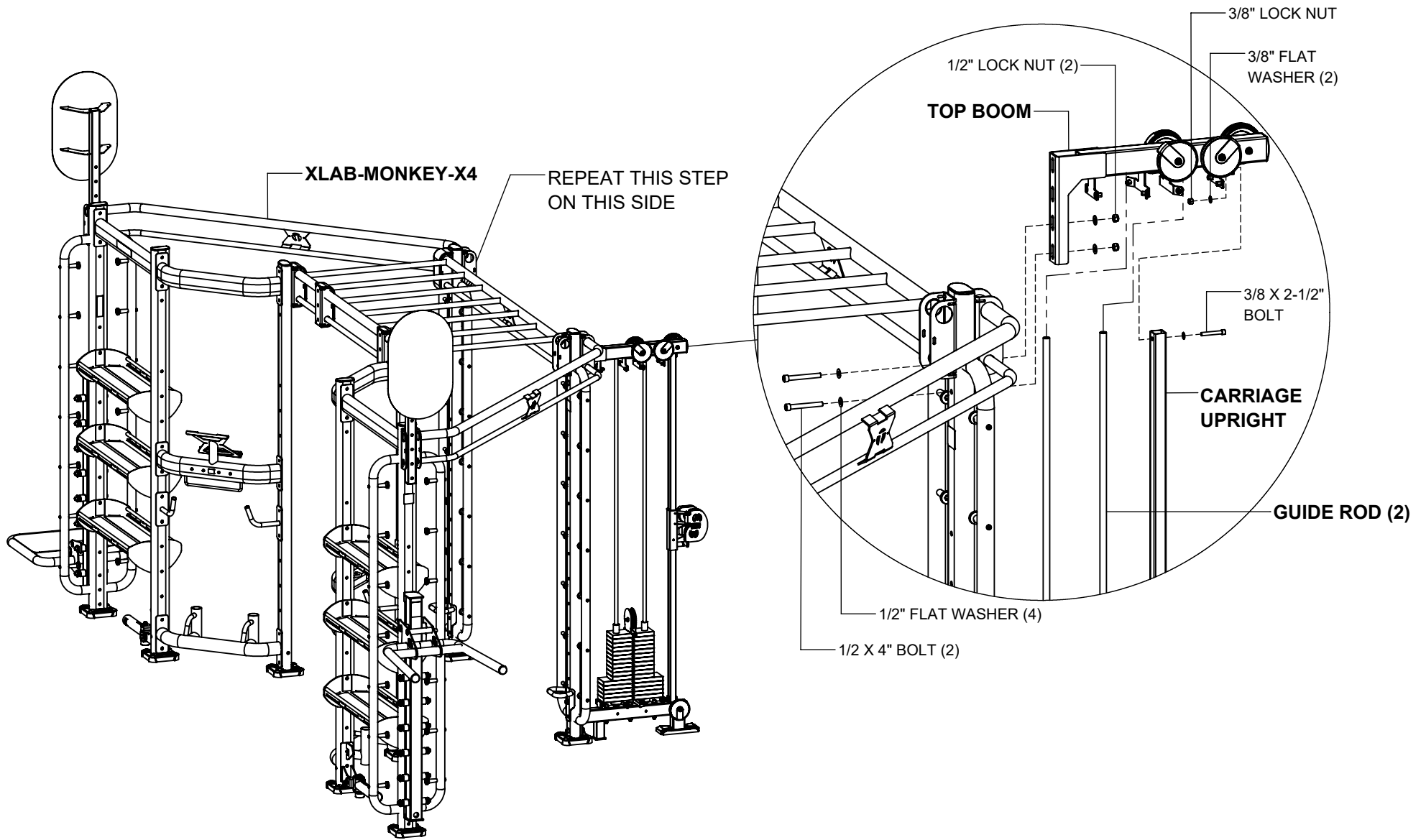

NOTE:

SECURELY assemble all bolt connections in this step.

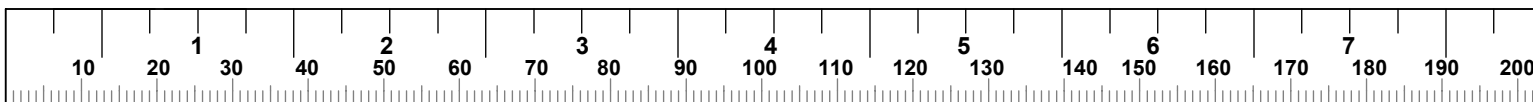

STEP 6f

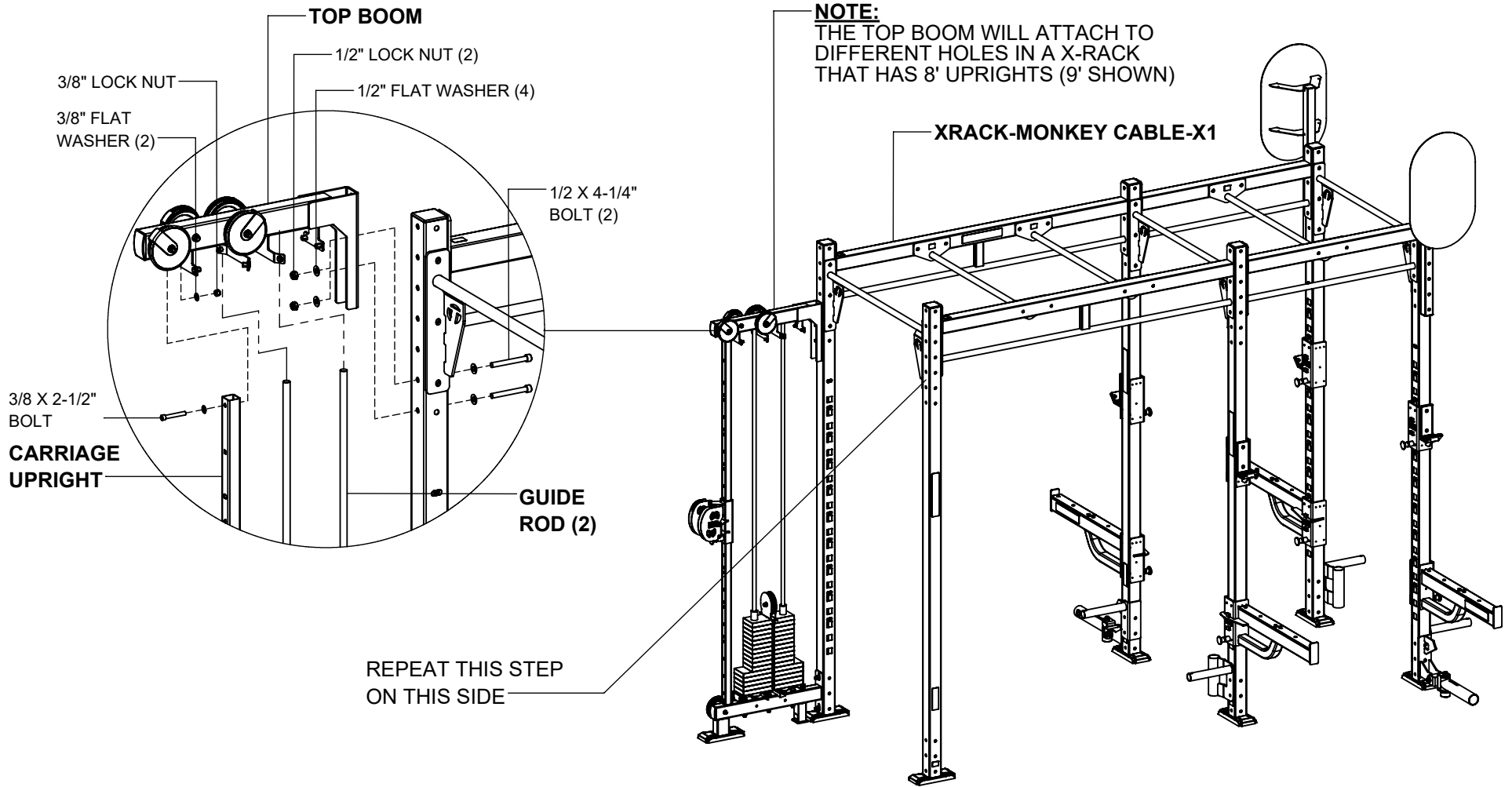

NOTE:

SECURELY assemble all bolt connections in this step.

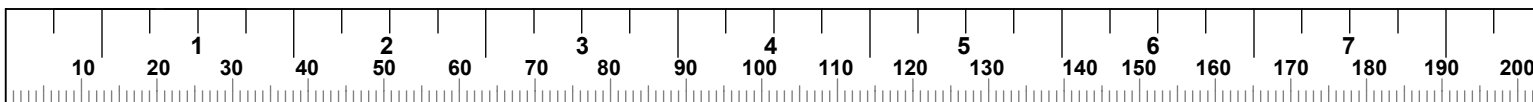

STEP 6g and 6h

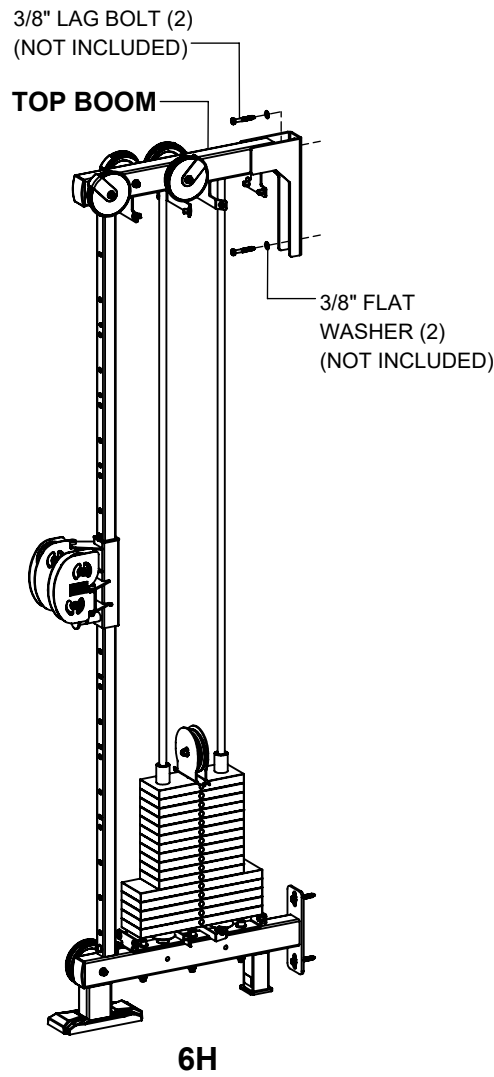
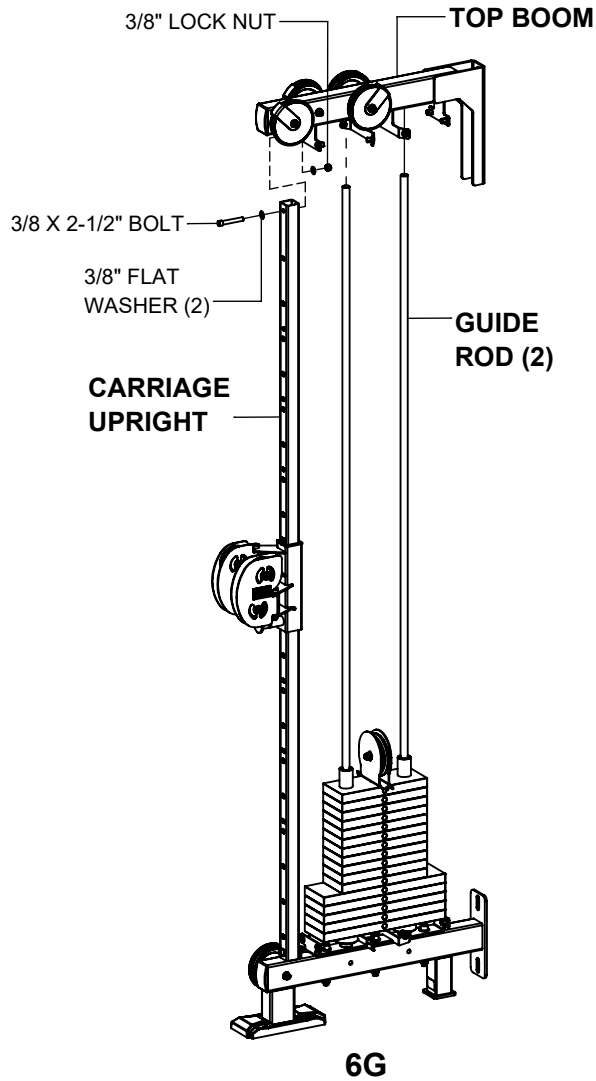

WARNING:

THE TOP BOOM **MUST** BE ANCHORED TO THE WALL USING A MINIMUM OF TWO WALL ANCHORS SUITABLE FOR THAT PARTICULAR WALL CONSTRUCTION

NOTE:

MAKE SURE TOP BOOM IS LEVEL

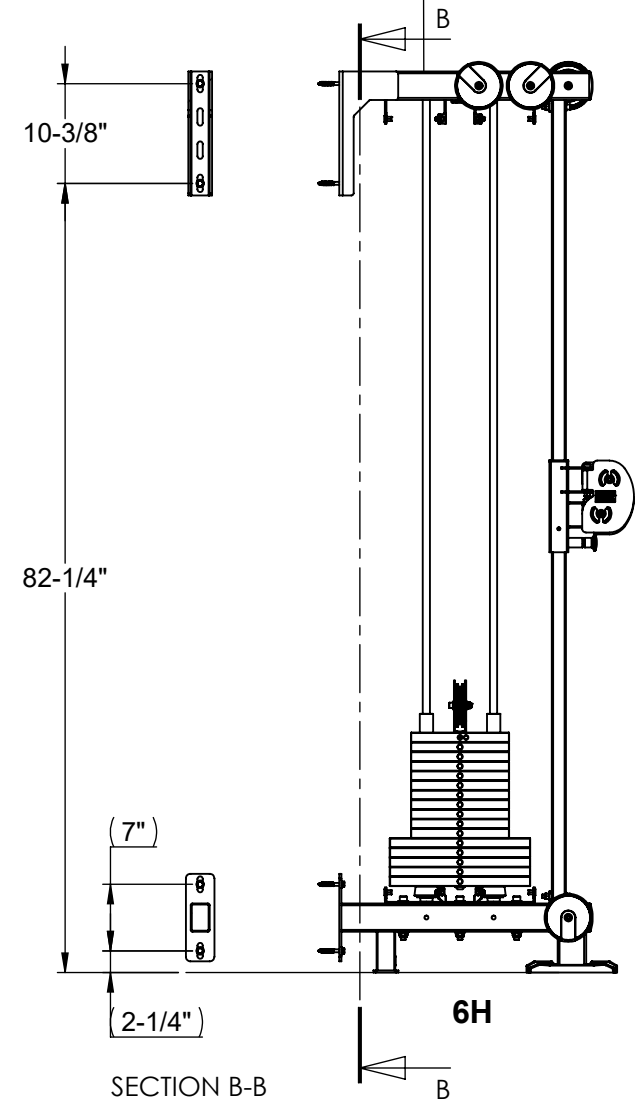

NOTES:

The images shown above is the anchoring hardware used for attaching to typical walls with wood studs spaced 16" on center. The anchors used will depend on the wall construction. In all cases, all four anchoring locations must be used. The pull-out strength of the anchoring bolts used must be greater than or equal to 200lbs. (91kg)

SECURELY tighten bolt connections in this step.

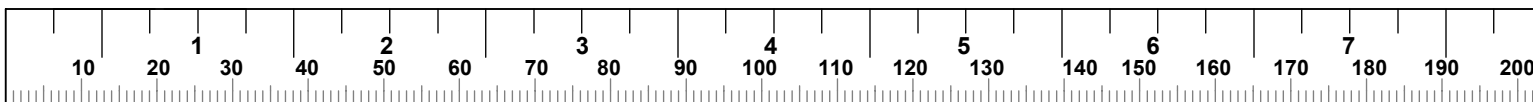

STEP 7

NOTE:

SLIDE GUIDE ROD RETAINERS UP INSIDE THE TOP BOOM. SLIDE SHAFT COLLARS UP INSIDE OF GUIDE ROD RETAINERS AND **SECURELY** TIGHTEN SET SCREWS OF SHAFT COLLARS

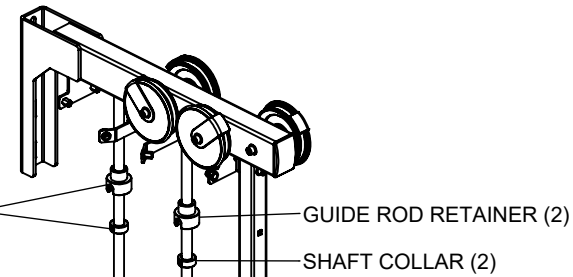

NOTE:

ONCE THE WEIGHT STACK HAS BEEN ASSEMBLED, LIFT UP ON GUIDE RODS AND **SECURELY** ASSEMBLE THE BOLTS, WASHERS AND NUTS TO THE BASE UNDERNEATH THE GUIDE RODS. GUIDE RODS REST ON TOP OF BOLTS.

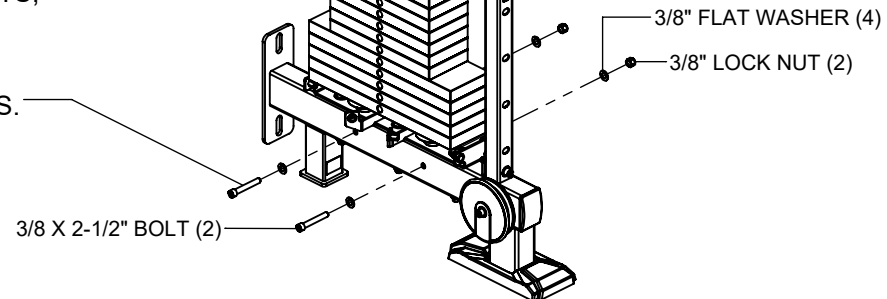

SECURELY tighten all bolt connections in this step.

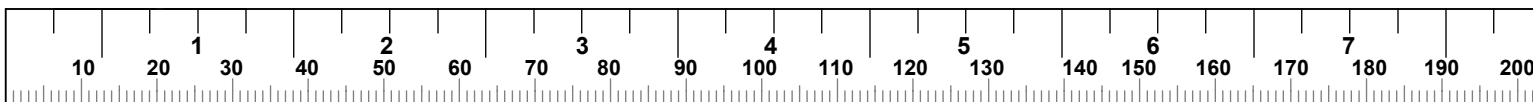

STEP 8a
CABLE ROUTING

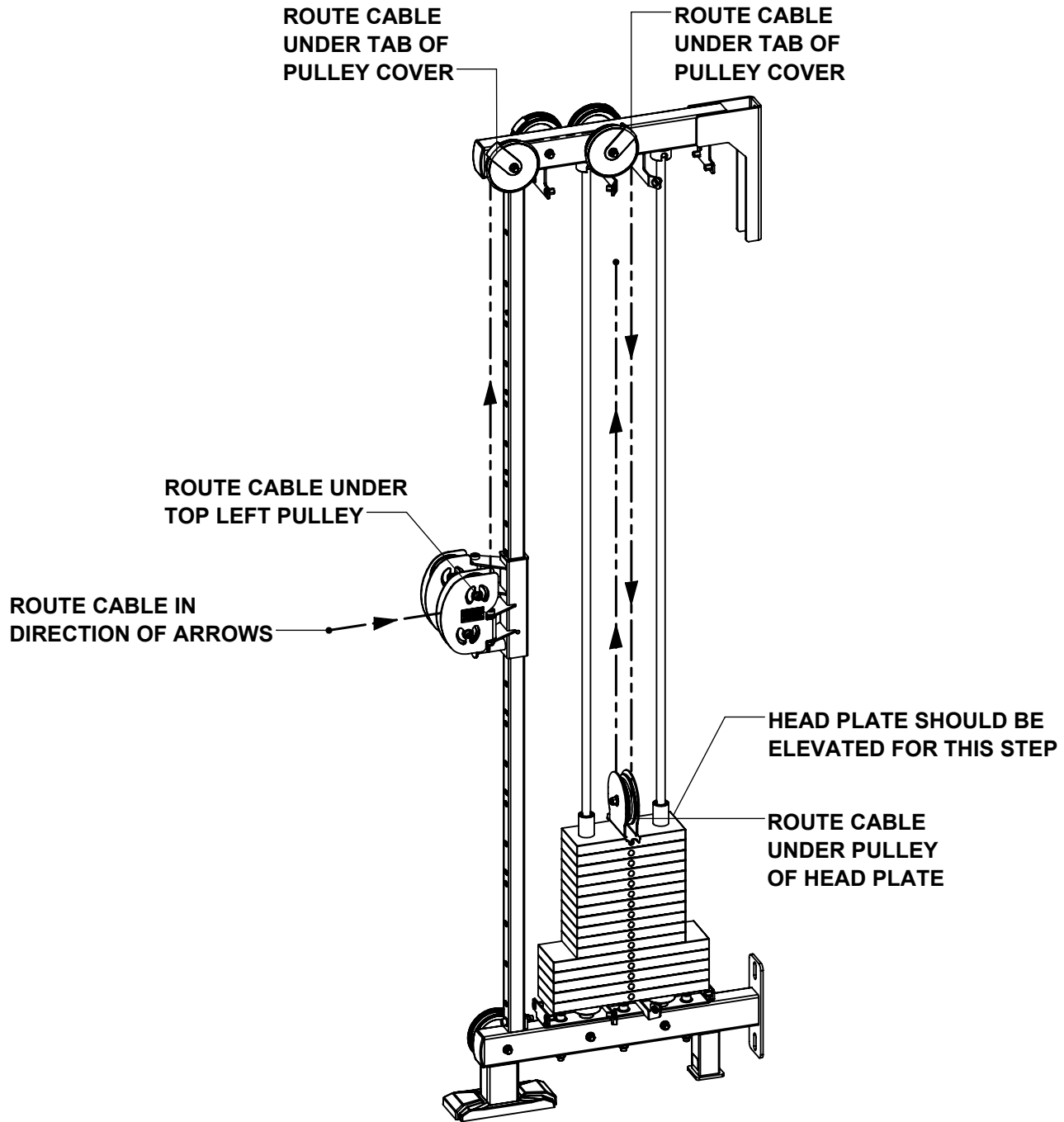

STEP 8b
CABLE ROUTING

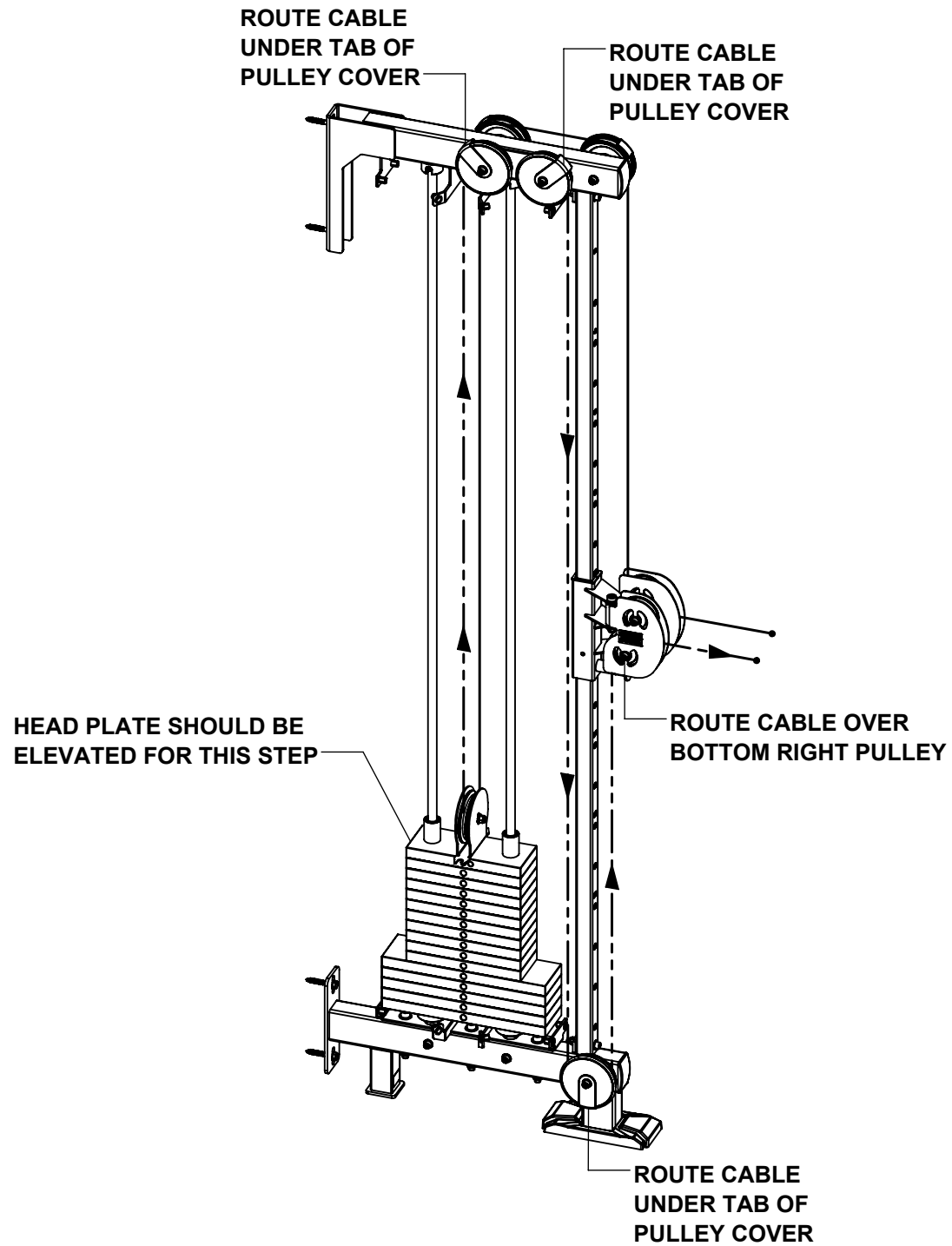

STEP 9a

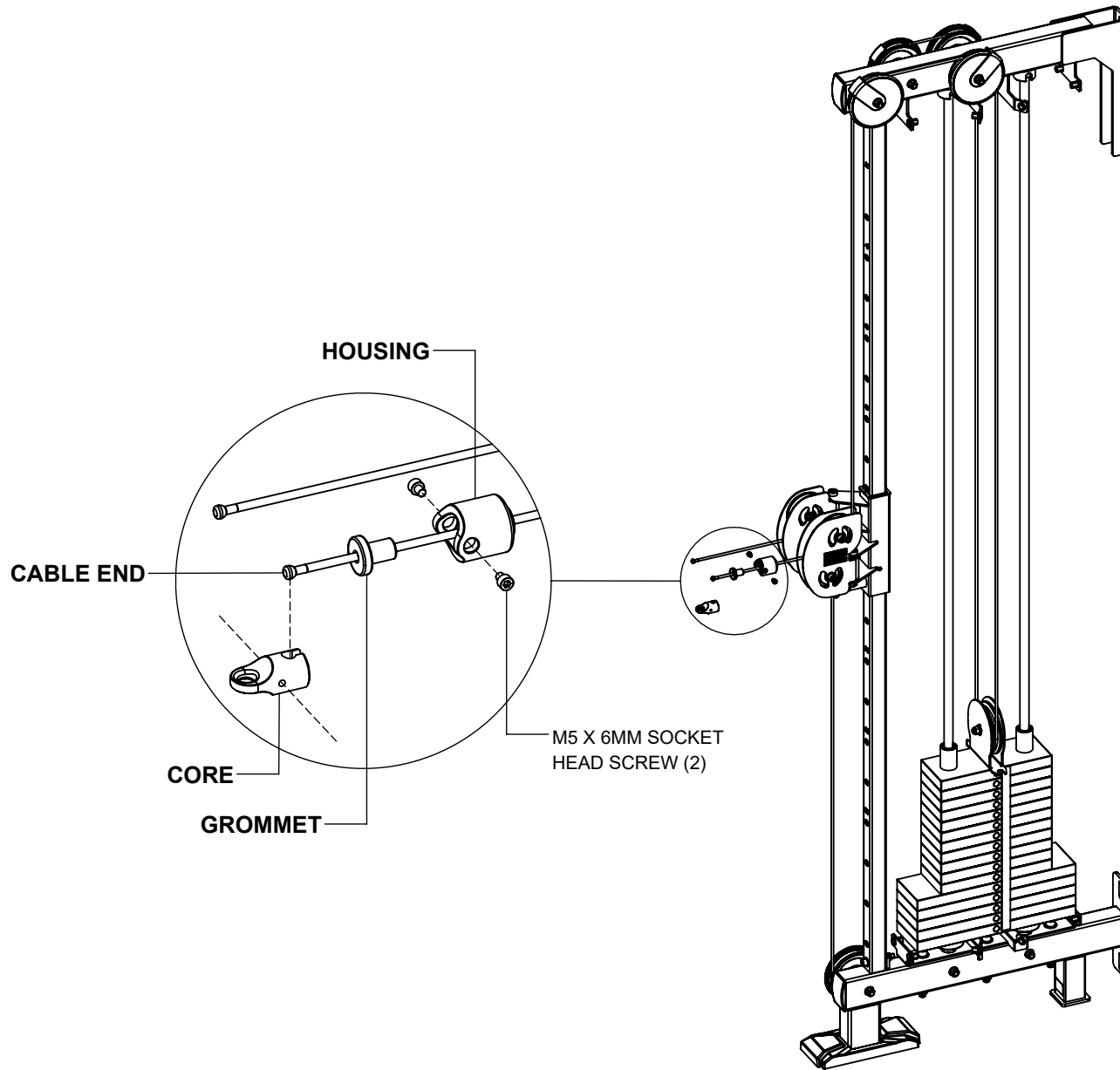

SECURELY tighten all bolt connections in this step.

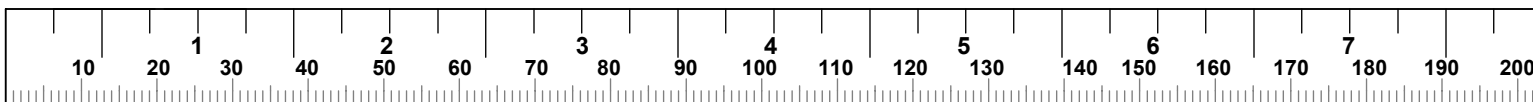

STEP 9b

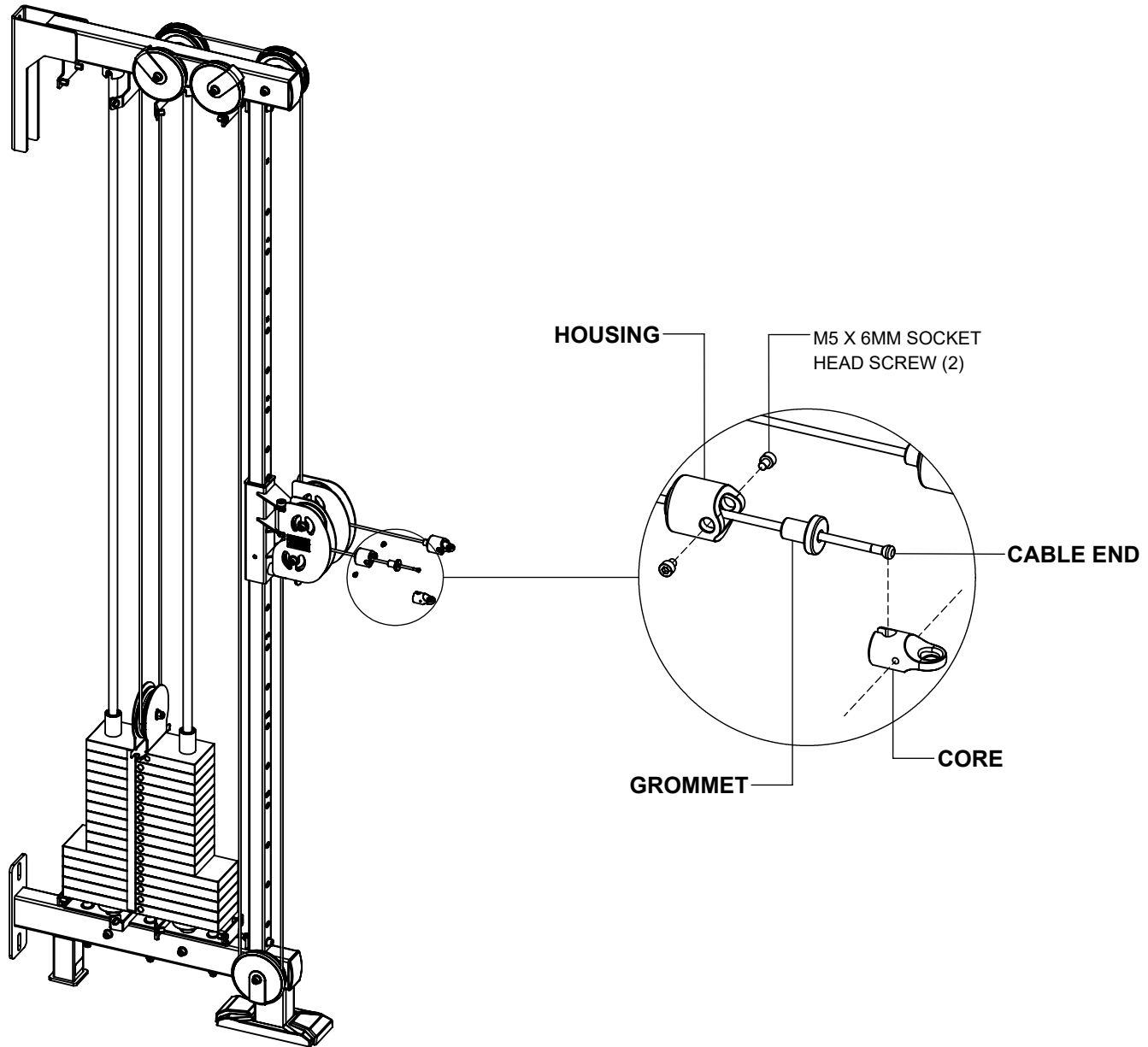

SECURELY tighten all bolt connections in this step.

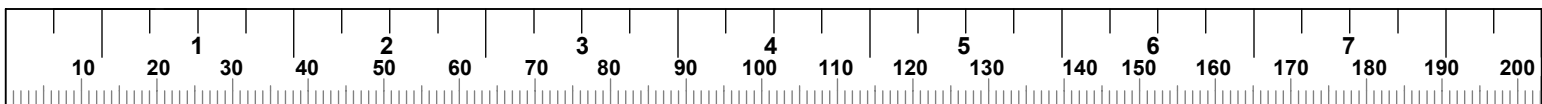

STEP 9c

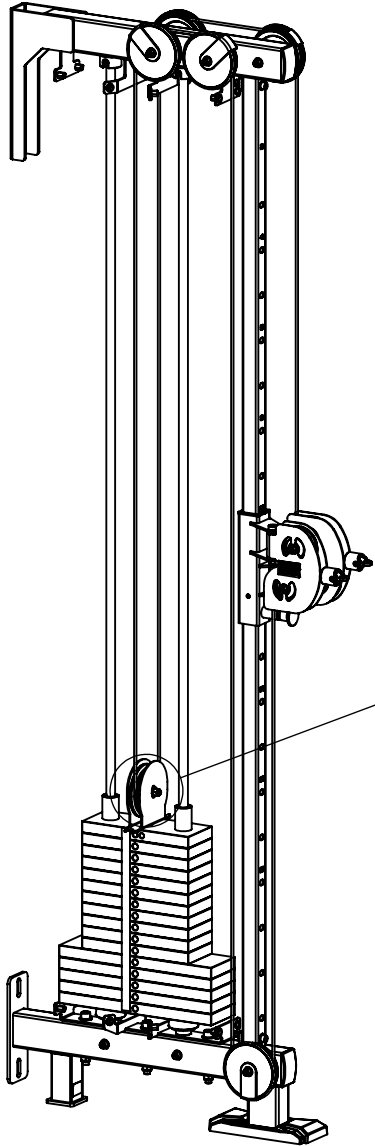

NOTE:
IF HEAD PLATE IS NOT SITTING
FLAT ON TOP OF FIRST WEIGHT
PLATE, LOOSEN THIS BOLT AND
ADJUST PULLEY UP TO CREATE
SLACK IN CABLE. RE-TIGHTEN
BOLT CONNECTION **SECURELY**.

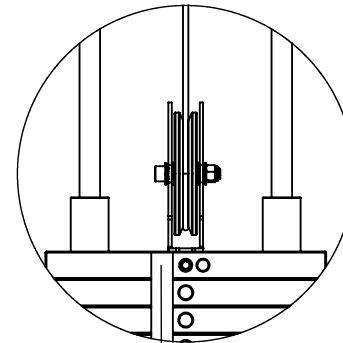
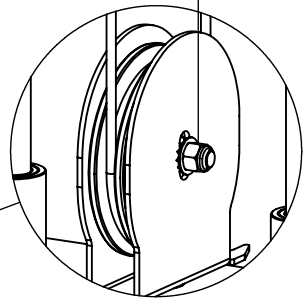

NOTE:
ATTACH THE WEIGHT STACK
LABELS TO BOTH SIDES OF
THE WEIGHT STACK, STARTING
WITH THE HEAD PLATE.

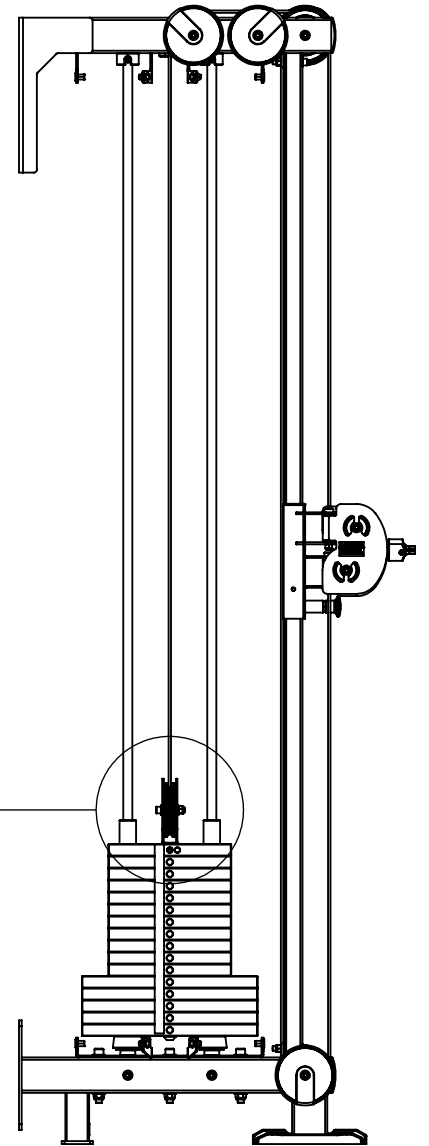

STEP 10

NOTE:
RIGHT FRONT
SHROUD HAS
A PLACARD

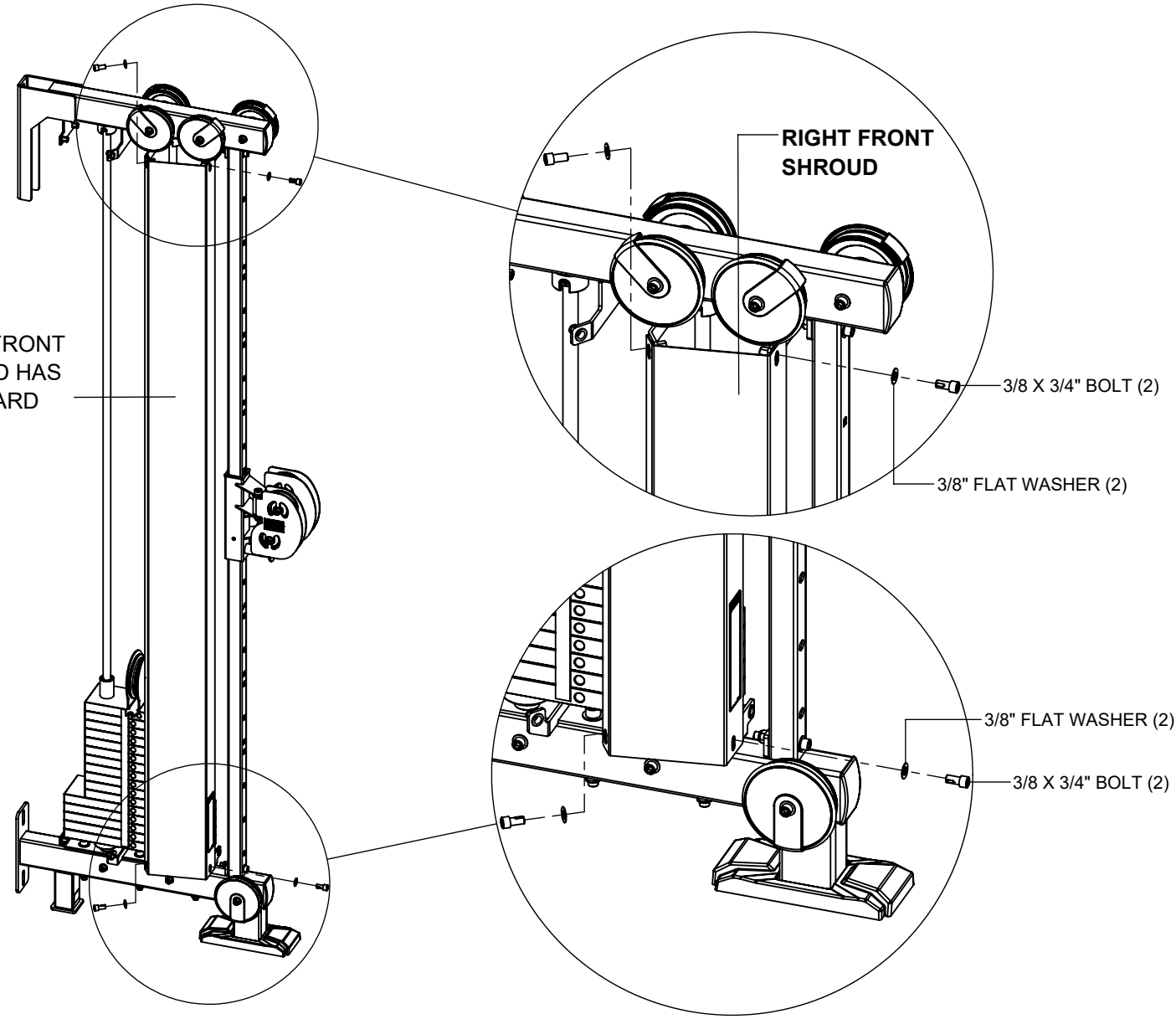

SECURELY tighten all bolt connections in this step.

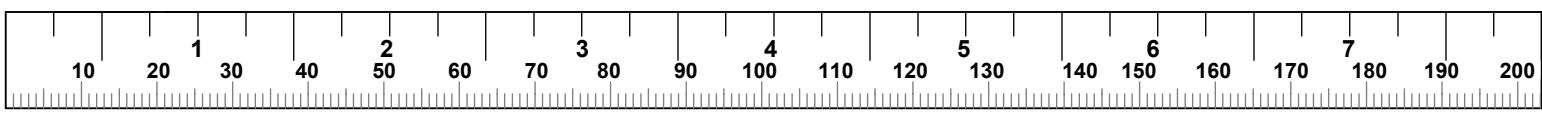

STEP 11

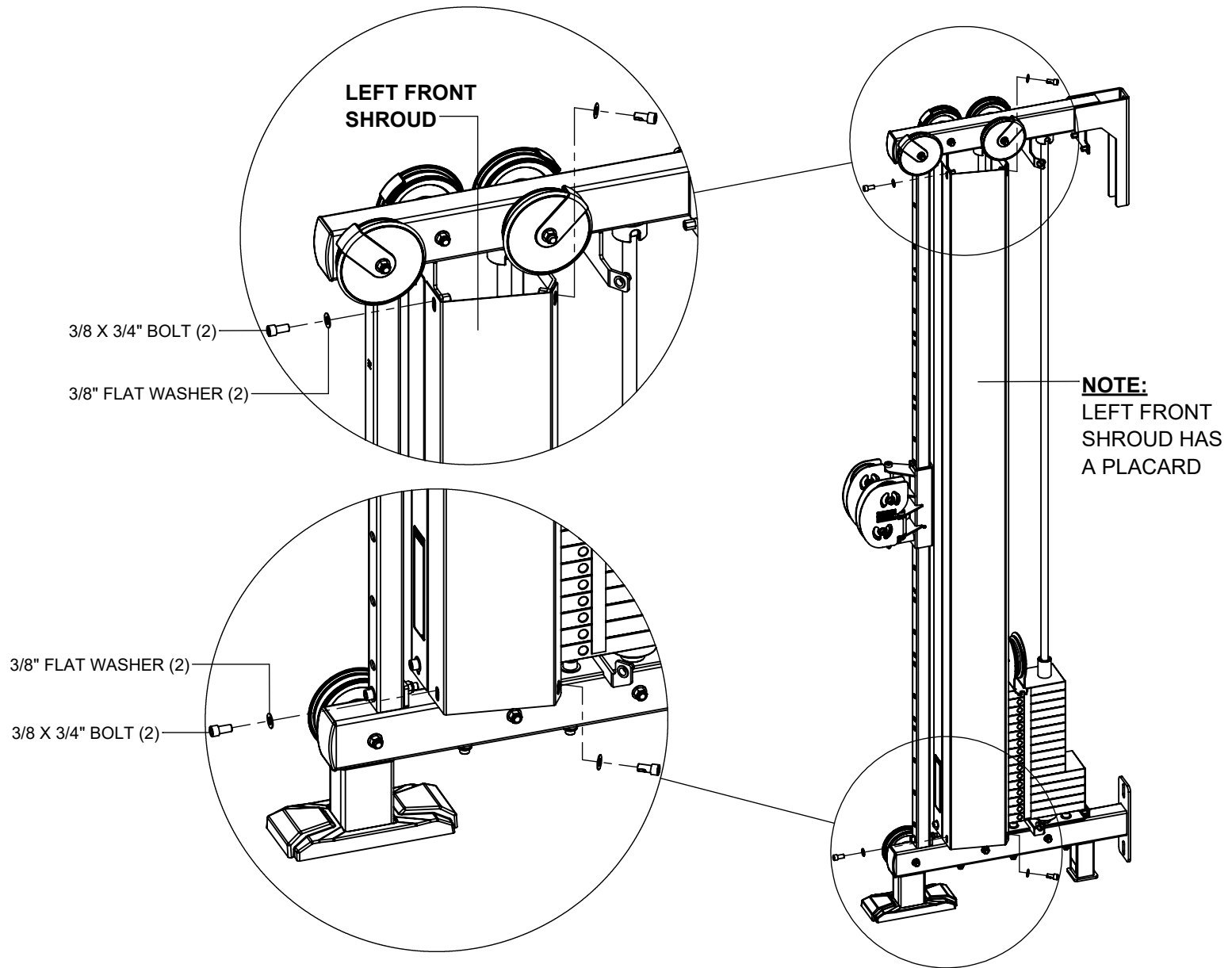

SECURELY tighten all bolt connections in this step.

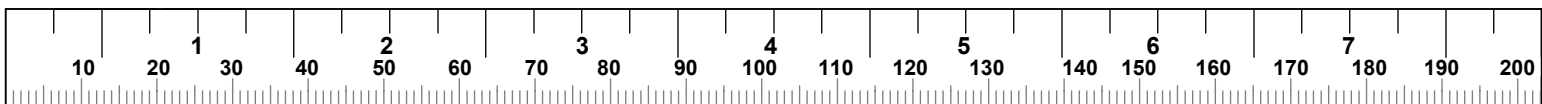

STEP 12

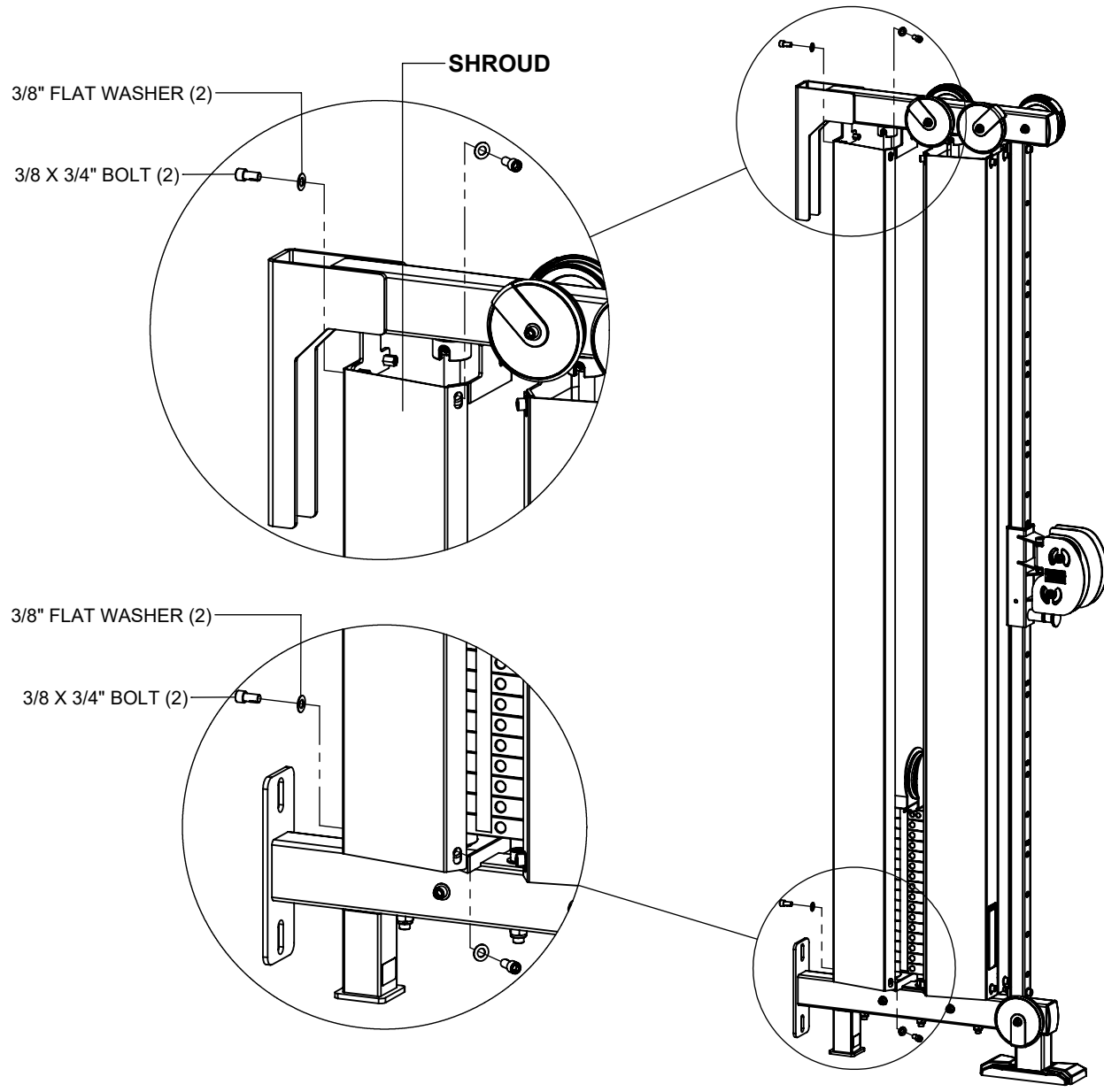

SECURELY tighten all bolt connections in this step.

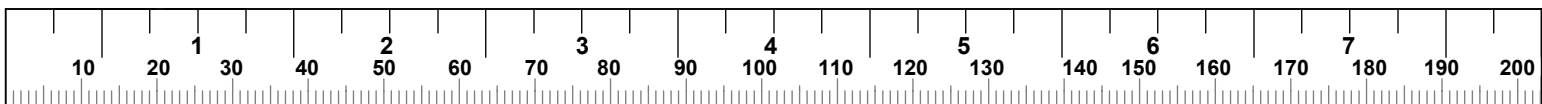

STEP 13

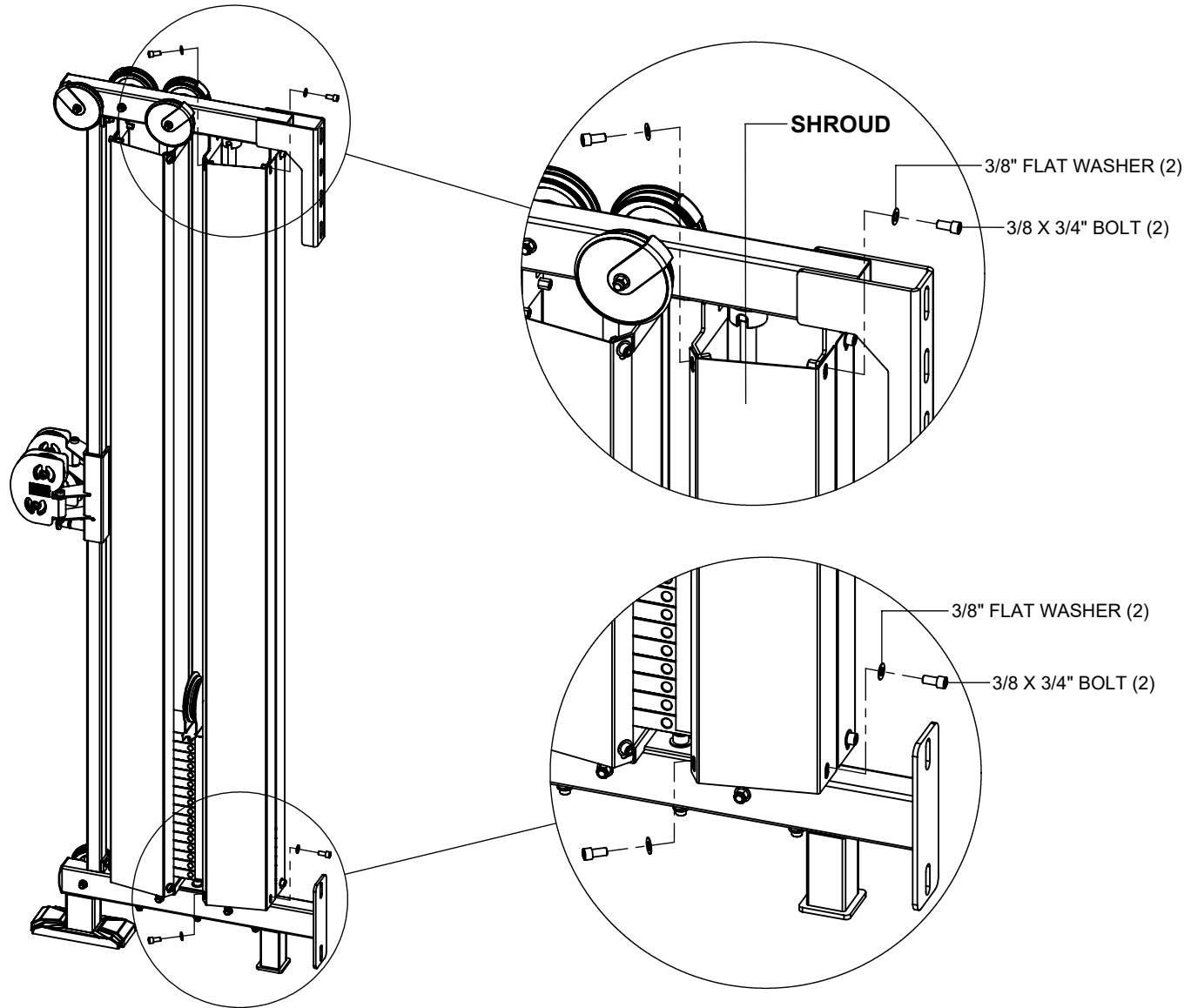

SECURELY tighten all bolt connections in this step.

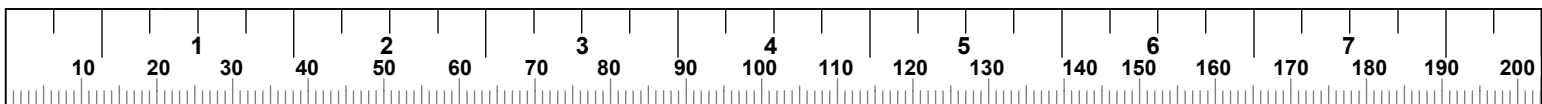

STEP 14

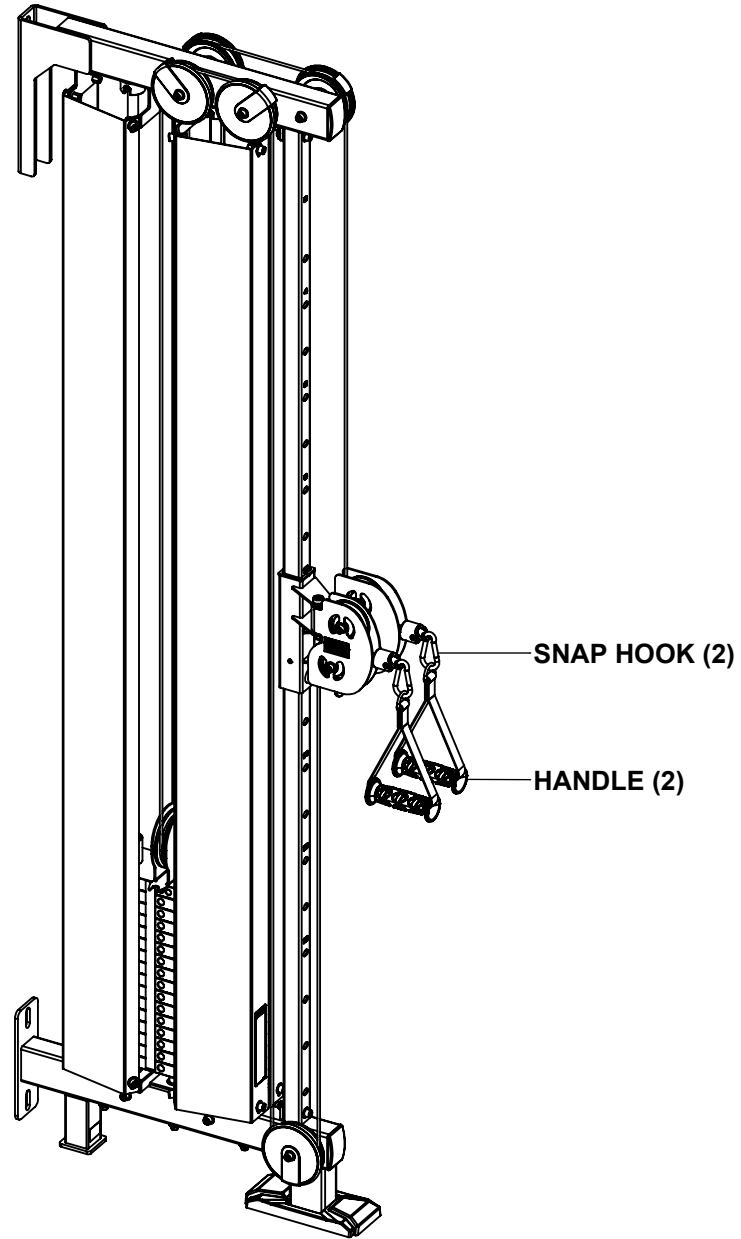

MAINTENANCE

GUIDE RODS: Clean and lubricate with a silicone or teflon based lubricant

INSPECTION: Once a month, check for loose bolts. Tighten if necessary.

CABLES: Check tension, end fitting and cable coating. Replace if damage or worn. (NOTE: NEW CABLES ALWAYS STRETCH DURING USE REFER TO STEP 9a, PAGE 24 TO ADJUST CABLE TENSION)

SPRING PINS: Check that the SPRING PINS fully engage when release. Tighten SPIRING PIN NUTS as needed.

FRAME: Clean with a damp cloth.

