

# OWNER'S GUIDE

---

## 900 LEGACY





## WIRELESS DIGITAL HYBRID NOISE CANCELLING HEADPHONES WITH TOUCH INTERFACE

- Please follow the directions and read the guidelines carefully before use.
- Please keep the owner's guide for future reference.
- Some functions of the 900 LEGACY may not be available when it is paired with certain devices.
- The specifications are subject to change without prior notice for quality improvement.

### CONTENTS

1. SAFETY AND GENERAL INFORMATION
2. COMPONENTS & FEATURES
3. CHARGING
4. POWER ON/OFF AND HEADPHONE CONNECTION WAITING MODE
5. PAIRING WITH A 'BLUETOOTH DEVICE'
6. NOISE CANCELLING FUNCTION
7. MONITORING (AUDIO TRANSPARENCY)
8. LISTENING TO MUSIC (PLAY & CONTROL)
9. USING THE CALL FUNCTION
10. ACCEPTING / MAKING A CALL WHILE PLAYING MUSIC
11. DISCONNECT NOTIFICATION
12. CONNECTING AND USING THE AUDIO CABLE
13. MISCELLANEOUS FEATURES
14. SPECIFICATIONS
15. PRODUCT ISSUES AND TROUBLESHOOTING
16. FCC COMPLIANCE INFORMATION
17. CE COMPLIANCE INFORMATION

## 1. SAFETY AND GENERAL INFORMATION

- 1) Use a standard USB charging cable (included) with or without a charging adaptor. (5V, over 1 A)  
\* Adaptor Not Included.
  - 2) Sudden, loud music can potentially cause hearing damage. Lower the volume before placing headphones on your ears and gradually increase the volume until a comfortable level has been reached.
  - 3) Listening to loud music for extended periods of time may cause hearing damage.
  - 4) Do not store the device in places with a temperature higher than 113 °F / 45 °C.
  - 5) Do not attempt to disassemble, modify or repair the device.
  - 6) Do not cause shock to the device.
  - 7) Keep out of reach of children and pets.
  - 8) Do not tug on cords or touch power plugs with wet hands.
  - 9) Do not use the device near microwave ovens or wireless LAN adaptors.
  - 10) When cleaning the device, use a clean dry cloth to wipe the device clean. (Do not use solvents.)
  - 11) When the product is not being used, please keep it in the Protective Case.
  - 12) Replacement ear pads can be purchased from Phiaton Customer Service.  
Email us at [SUPPORT@PHIATON.COM](mailto:SUPPORT@PHIATON.COM)
  - 13) Using the device while walking or driving may prevent user from hearing important sounds such as signals or alarms and may impose hazardous conditions on yourself or others. Heed caution during use.
  - 14) The radio waves of this device may affect electronic medical devices. If you use any electronic medical device, consult your doctor or the medical device company before you use.
- ※ Use the 900 LEGACY only for its intended purposes.
- ※ This device cannot be used for purposes related to human safety as it may cause radio interference during operation.

## 2. COMPONENTS & FEATURES

### 1) Contents

- 900 LEGACY
- USB-A TO USB-C Charging cable
- Audio Cable (1.0 m, 3.5 mm to 3.5 mm Plug)
- Carrying Case
- Quick Guide
- Warranty Card

### 2) Features

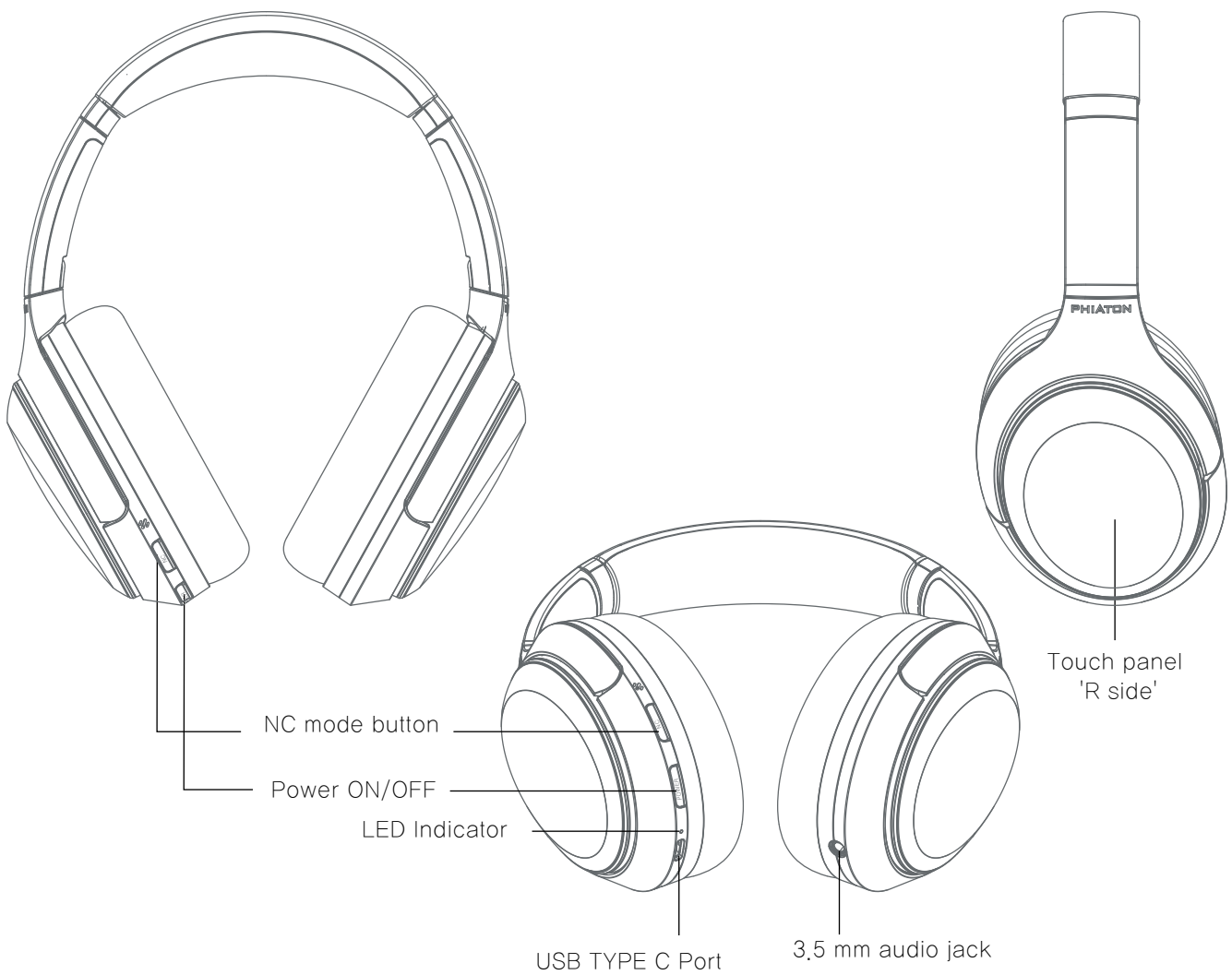



### 3. CHARGING

The device may have low battery and should be charged before first use.

- 1) Connect the provided USB charging cable to 900 LEGACY.
- 2) Connect the provided USB charging cable with a computer (laptop) or you may also use an USB adaptor (purchased separately) with a minimum rating of 5V (over 500mA).

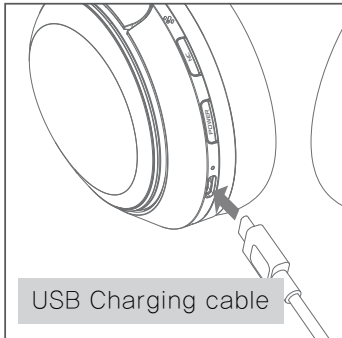

Operation	LED indicator
Charging	Red Light
Charging complete	Blue Light

- This device has a built-in battery, and will begin charging automatically when you connect the charging cable.

### 4. POWER ON/OFF AND HEADPHONE CONNECTION WAITING MODE

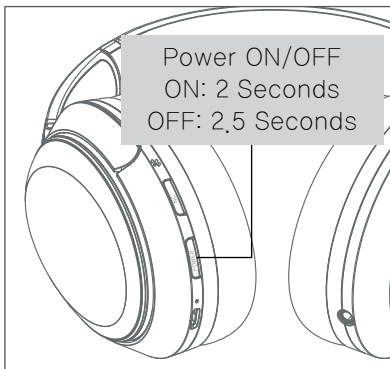

#### 1) Power ON/OFF

- Press and hold the 'Power' Button for 2 seconds to turn the power on.
- When turning the power off, press and hold the POWER Button for 2.5 seconds to turn off.

Status	Operation	LED Indicator	Notice
ON	Press and hold the POWER Button for 2 seconds	After Purple light, Blue light blinks 2 times	Sound effect
OFF	Press and hold the POWER Button for 2,5 seconds	Red light blinks 5 times	Sound effect

※ When powering on for the first time after purchase, pairing mode is automatically activated.

#### 2) Connection Waiting Mode

- When power is turned on, 'Connection Waiting Mode' will start if 'Pairing Mode' cannot be entered or the headphones cannot connect with 'Bluetooth Device'.
- If the 'Bluetooth Device' is not connected within 5 minutes in 'Connection Waiting Mode', the headphones will automatically turn off.
- \* At Connection Waiting Mode, the headphone should be entered to 'Pairing Mode' for connection to 'Bluetooth device' again after power off. If not, 900 LEGACY will turn off within 5 minutes after starting 'Connection Waiting Mode'.

Status	LED Indicator
Connection Waiting Mode	Blue light blinks twice in 6 second intervals

## 5. PAIRING WITH A BLUETOOTH DEVICE

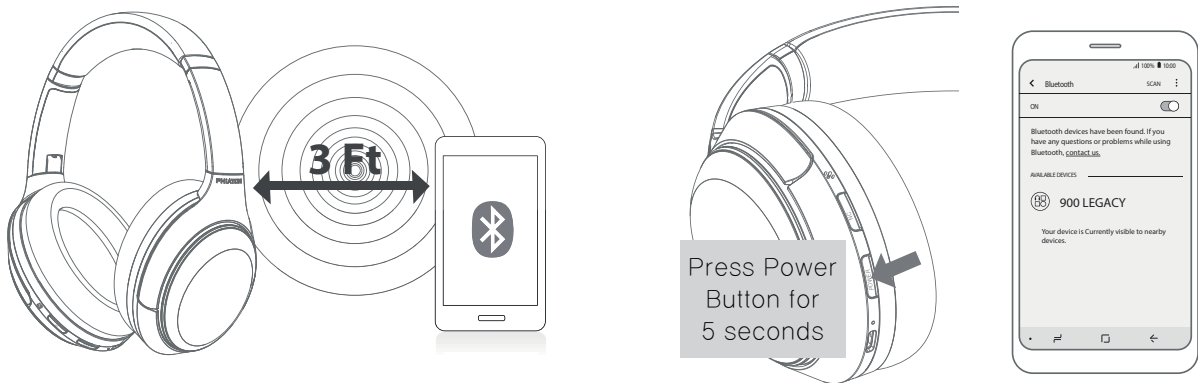

### 1) Pairing

- Turn on the Bluetooth feature with the 'Bluetooth Device' you want to connect with the 900 LEGACY.
- Place the 900 LEGACY within 3 feet of the 'Bluetooth Device' you want to connect.
- Press and hold the POWER Button for over 5 seconds with the 900 LEGACY power on to enter Pairing Mode. Pairing mode will start once the power is turned on for the first time after purchase.

Status	LED Indicator	Voice Guidance
Pairing Mode	Blue and Red light alternately blinks	Pairing Mode activated

- Within the 'Bluetooth Device' you want to connect, search/select '900 LEGACY'.

※ If the 'Bluetooth Device' requires a PIN CODE or password, enter '0000'.

- Use the headphones to play music or connect a call.

Operation	LED Indicator	Voice Guidance
Connection success	After Purple light blinks twice, Blue light blinks once in 6 second intervals	Device connected

### 2) Re-connecting a Disconnected Device

#### ① Auto Connection

- Once the device has been paired with a 'Bluetooth Device' it will automatically be connected to a previously connected device once the 900 LEGACY power is turned on.
- If Bluetooth becomes disconnected and the range between the 900 Legacy and the 'Bluetooth Device' is exceeded, then Bluetooth will not be automatically reconnected when back in range. When you are back within the discover range (33 feet), you must then connect manually.

#### ② Manual Connection

- When having entered 'Connection Waiting Mode' during connection,
- Press the POWER Button on the headphone to connect,
- The 900 LEGACY will also be connected if you select '900 LEGACY' from the device search list within your 'Bluetooth Device'.

### 3) Checkpoints Upon Pairing

- Check to see whether the Bluetooth mode is activated within the 'Bluetooth Device' you want to connect.
- When selecting the connection device, connect by selecting stereo headset device. Music cannot be played when connected through mono headset.

※ In order to properly use the Bluetooth feature of this device, the profile (A2DP, HSP, HFP and AVRCP) of the 'Bluetooth Device' you are trying to connect must support the profile of this device.

\* A2DP—"Advanced Audio Distribution Profile", HSP—"Headset Profile", HFP—"Hands Free Profile",  
AVRCP—"Audio/Video Remote Control Profile"

※ The device will not operate properly if the profiles are not supported equally.

Even when the profiles are supported equally, some features may not properly operate depending on the 'Bluetooth Device' specifications. To check the detail specifications of this headphone's profile, refer to '14. SPECIFICATIONS'. For more information, please visit [phiaton.com](http://phiaton.com) or contact Phiaton customer service.

## 6. NOISE CANCELLING FUNCTION

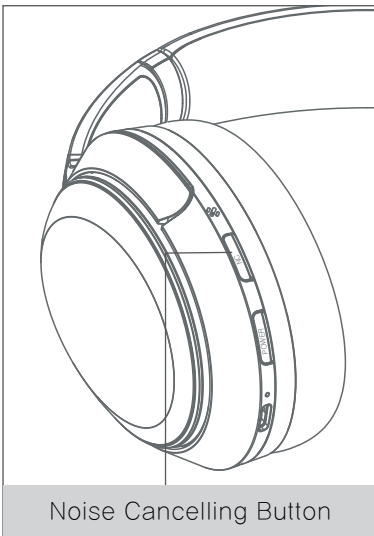

1) What is 'Noise Cancelling'?

– Noise Cancelling refers to a technology that reduces noise from mid/low pitched sounds under 1kHz.

2) Turning Noise Cancelling

– The Noise Cancellation function is automatically activated when the device is powered on or when the audio cable is plugged in. When pressing the Noise Cancellation button you will activate the Audio Transparency feature which will allow you to hear the sounds around you better. Hit the NC button again and Noise Cancellation feature is activated again.

3) Cautions in regards to the Noise Cancelling function

– The Noise Cancelling function cannot be used when the battery is completely discharged or completely empty.  
– Using this function while driving or walking could prevent outside noise, such as signals or alarms, from being heard and may present a hazard to yourself and others. Proceed with caution when in use.  
– Noise Cancelling is optimized for mechanical noises from airplanes, buses, and subway trains and is not necessary within quiet indoor environments.

## 7. MONITORING (AUDIO TRANSPARENCY)

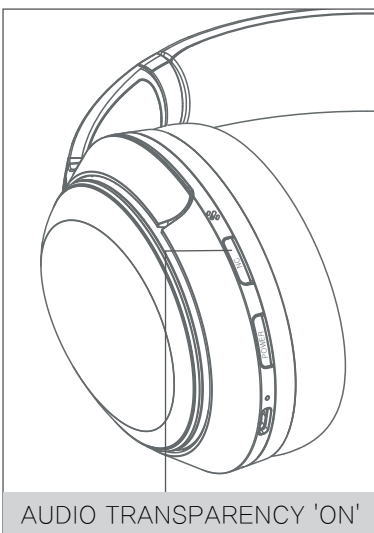

1) The AUDIO TRANSPARENCY feature allows you to stop noise cancelling temporarily so you can hear the surrounding sounds without removing the headphone.

2) When AUDIO TRANSPARENCY is activated, the noise cancelling function is stopped and external sounds can be heard.

3) When the NC button is pressed while the noise cancelling function is running, the AUDIO TRANSPARENCY is activated.  
Press again to stop the AUDIO TRANSPARENCY.

## 8. LISTENING TO MUSIC (PLAY & CONTROL)

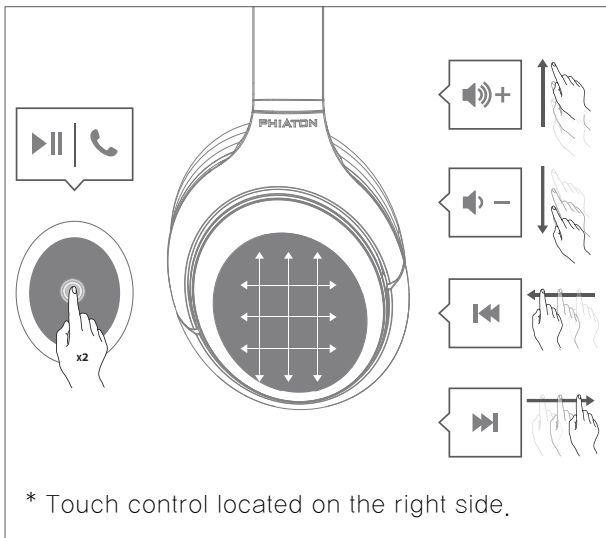

### 1) Playing Music

- Double tap touch panel or press the POWER button for about 1 second to play music from the 'Bluetooth Device'.
- While music is playing, double tap touch panel or press the power button for about 1 second to pause the music. The music will resume from the paused point when playing music again.

\* SBC (Sub Band Codec) is default audio codec installed for any 'Bluetooth Device'.

\* aptX and AAC are high quality audio codec.

### 2) Controlling Volume and Using Seek

- Swipe the touch panel Up (Vol +)/ Down (Vol-) to control the volume.
- Swipe the touch panel Forward (FF)/ Backward (REW) to go to the next/previous song.

\* Music can be listened to through 900 LEGACY by directly operating your 'Bluetooth Device'.

\* When the battery is completely drained, you can connect the provided audio cable to continue listening.

### 3) Smart Play/Pause

- 900 LEGACY has Smart Play/Pause function that can detect whether the headphone is being worn or not.
- The function can play or pause music automatically.  
(Play when headphones are worn on the ears/Pause when the headphones are removed from the ears.)
- To continue playing music when the headphones are not worn on the ears, double tap the touch panel or press the POWER button.

## 9. USING THE CALL FUNCTION

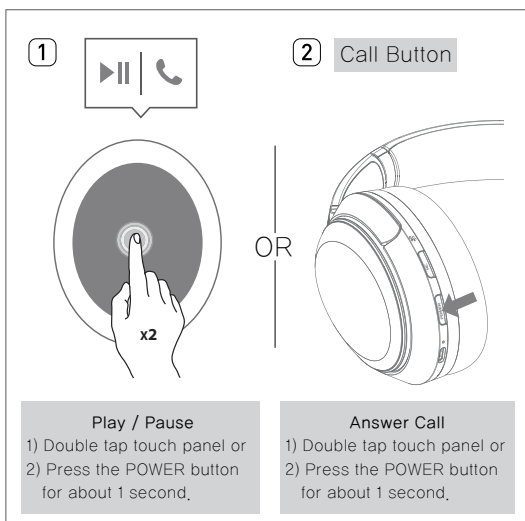

### 1) Accepting a Call while Playing Music

- When an incoming call tone is heard through the headphones, quickly double tap the touch panel or press the POWER button. The music will pause and the call will be connected.
- Once the call has ended, quickly double tap touch panel again or press the POWER button to terminate the call. Once the call is terminated, the paused music will play again.

## 10. ACCEPTING / MAKING A CALL WHILE PLAYING MUSIC

### 1) Accepting a Call

- When an incoming call tone is heard through the headphones, quickly double tap the touch control panel or press the POWER button. (Volume control: While on a call, use the touch panel to control volume.)

### 2) Ending a Call

- While on a call, quickly press the POWER button or quickly double tap the touch control panel to end the call.

### 3) Rejecting a Call

- When an incoming call tone is heard through the headphones, press and hold the POWER button for about 1 second. (After hearing the 'beep' signal tone, the incoming call is rejected and the voice guidance "Call Ignored" is heard.)

### 4) Call Waiting

- When receiving another incoming call while on a call.  
(Supported only when having applied for this service with your telecom provider.)
- Press and hold the POWER button for about 1 second to place the current call on call waiting and connect the second call.  
(Press the POWER button again for about 1 second to switch between the waiting call and connected call.)
- Shortly press the POWER button to end the current call and connect the second call.

### 5) Switching between Mobile Phone to 900 LEGACY

- To switch the call from mobile phone to the headphone, press the POWER button for 1 second.

Status	LED Indicator
Incoming Bell/Outgoing Bell	Purple light blinks in 1,5 second intervals
During Call	Blue light slowly blinks every 6 seconds
When there are two calls connected	Purple light slowly blinks every 6 seconds

### ※ Battery use time

Status	Noise Cancelling 'ON'
Call Time	Max. 39 hours
Music Play Time	Max. 43 hours
Standby Time	Max. 320 hours
10 min. Charging	Max. 4 hours
Full Charging Time	About 3,3 hours

\* The above times may differ depending on the environment in which it is used.

## 11. DISCONNECT NOTIFICATION



Vibration rings for 2 seconds and beep sound, then beep sound is repeated 5 times in 20 seconds intervals.

- 1) The 900 LEGACY vibrates when you are out of communication range (about 10 m/33 ft.) from the 'Bluetooth Device'.
- 2) The disconnect notification function first alerts you with a vibration for 2 seconds and a beep sound; the beep sound is repeated 5 times in 20 second intervals.
- 3) If you continue to be out of range for more than 20 seconds, the 900 LEGACY will enter 'Connection Waiting Mode' after notifying you with vibration and beep sounds, along with a voice prompt of 'Device Disconnected'.
- 4) If you move back into communication range before the notification completes the fifth interval, you will stay connected to your 'Bluetooth Device'.
- 5) If you do not move back into communication range until after the notification has ended, you will need to manually reconnect to Bluetooth.

## 12. CONNECTING AND USING THE AUDIO CABLE

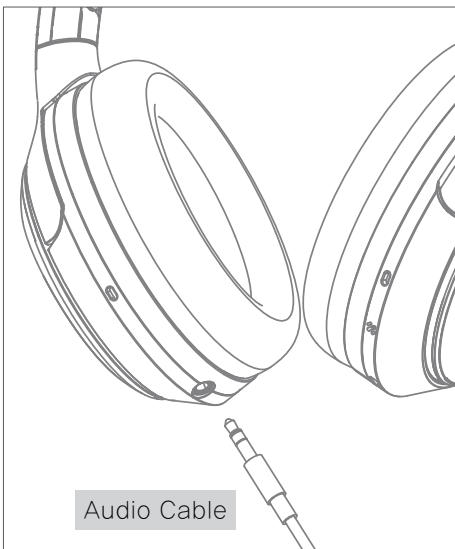

900 LEGACY can also be used with the audio cable connected as shown in the figure.

- \* When connected to a device with the provided audio cable, the Bluetooth remote features are disabled and you must use the features on the device you are connected with the audio cable to answer calls and play music

## 13. MISCELLANEOUS FEATURES

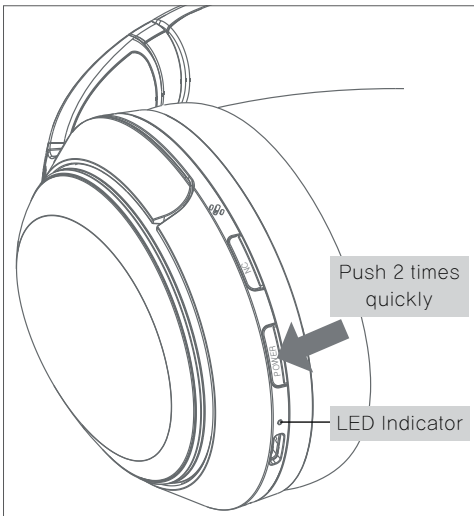

### 1) Checking Remaining Battery

- With the power on, short press the POWER button twice to display the remaining battery indicator (LED).
- For Apple iOS version 5 or above, the remaining battery is displayed at the top right side of the screen.

Remaining Battery	Voice Guidance
Over 80%	Battery is full
80% ~ 30%	Battery is moderate
Under 30% Red light	Battery is low
Under 3%	Please recharge

\* The Battery Check feature will not operate while the battery is being charged.

\* When the battery charge is under 3%, the alarm will sound.

If headphone usage persists for several minutes the battery will be completely drained, the 'Power Off' voice guidance will be provided and the power will automatically turn off.

### 2) Resetting the Device

- To reset to factory settings, when powering off, continue to press and hold the power button for over 10 seconds and device will reset itself.

Operation	LED Indicator
Factory Settings	5 times Purple light blinking

## 14. SPECIFICATIONS

### 1) Main body

- Communication Network: Bluetooth 5.1
- Output Power: Power Class 2
- Max. Communication Range: Discoverable within 10 m / 33 ft.
- Full Charging Time: 3 hour 20 minutes
- Call Time : Max. 39 Hours
- Music Play Time : Max. 43 Hours
- Standby Time : Max. 320 Hours
- Operating Frequency: 2.4 GHz (2,402 GHz ~ 2,480 GHz)
- Bluetooth Profile Support: HFP v1.7 / HSP v1.2 / A2DP v1.3.1 / AVRCP v1.6
- Audio Codec: SBC, Qualcomm® aptX™ HD, aptX™ , AAC  
(If the 'Bluetooth Device' can not support Qualcomm® aptX™ or aptX–HD™ audio or AAC mode, it will be connected with SBC mode.)
- Battery: Lithium Polymer DC 3.7 V / 1000 mAh
- Microphone Frequency Range: 50 ~ 4,000 Hz
- Microphone Sensitivity: –42 dB
- Support Echo Cancellation and Talk Noise: cVc® Solution
- Operating Temperature: –20 ~ 45 ° C
- Size: 180 x 172 x 23 mm (H x W x D) / 7.1 x 6.8 x 0.9 inch (H x W x D)
- Weight: 256 g (0,56 lb)

### 2) Headphones

- Type:  $\varnothing$  40 mm Driver Units
- Sensitivity: 100 dB/mW
- Frequency Response: 10 Hz ~ 27 kHz
- Impedance: 16 ohms

\* The specifications are subject to change without prior notice for quality improvement.



## 15. PRODUCT ISSUES AND TROUBLESHOOTING

- 1) The power does not turn on:
  - Charge the device. If the power does not turn on even after charging, contact Phiaton Customer Service.
- 2) The device does not charge:
  - Check whether the USB charging cable has been properly connected with the device.
  - Check whether the PC power is on and that it has been properly connected.
  - When using an USB AC adapter, check to see that it is properly connected.
  - Check by plugging into a different port or outlet to ensure it isn't an issue with outlet or port.
- 3) The device does not pair:
  - Check whether the power of the 'Bluetooth Device' you want to connect is on.
  - Check whether the Bluetooth feature within the 'Bluetooth Device' you want to connect is enabled.
  - Check whether the 'Bluetooth Device' you want to connect is within the supported range.  
(Pairing is supported only when within 3 feet.)
  - Check whether the Bluetooth profile within the 'Bluetooth Device' is compatible.
  - Check whether the 900 LEGACY is in 'Pairing Mode'.
  - Power OFF, then try repairing again by following direction from 5. PAIRING WITH A 'BLUETOOTH DEVICE'.
  - Make sure the 900 Legacy is fully charged.
- 4) Music cannot be played:
  - Check whether the power of the device and 'Bluetooth Device' is on.
  - Check whether music is being played within the connected 'Bluetooth Device'.
  - Check whether the volume within the connected 'Bluetooth Device' is low.
  - When using an audio cord, check to see that the plug is properly connected.
- 5) Noise is heard or the sound lags:
  - Check whether there is an electronic device nearby using the 2.4 GHz frequency band and it's also Connected to the 'Bluetooth Device'. (i.e. Wi-Fi routers, smart devices, baby monitors, and etc.)
  - Check whether the connected 'Bluetooth Device' is far away from this device.  
(Maximum communication range: within 33 feet.)
  - Make sure there isn't an issue with Wi-Fi if streaming.
- 6) The music sound quality is low:
  - If the 'Bluetooth Device' you are trying to connect with this device is accessed to HSP, change the access to A2DP.
- 7) The other party cannot be heard while on a call:
  - Check whether the power of the 'Bluetooth Device' you want to connect is on.
  - Access Bluetooth through HFP or HSP.
  - Check whether the volume within the connected 'Bluetooth Device' is low.
- 8) Outside noise is too high or not reduced:
  - Check whether Noise Cancelling is turned ON.
  - Check if AUDIO TRANSPARENCY has been activated
- 9) Product does not work or operation has stopped:
  - Reset the device by simultaneously pressing the power button and connecting the USB charging cable.
  - This will power off the device but will not delete previously deleted devices.
  - This performs a hardware reset. Headphone power will be forced to quit but pairing history will remain.
  - This method is recommended when headphone or function keys do not work.
- 10) The device is paired with PC/Laptop but does not work:
  - PC/Laptop is equipped with various Bluetooth drivers depending on the manufacturer and it is possible it does not support 900 LEGACY.
  - Please contact to PC/Laptop manufacturer to download the latest software driver or for further assistance in connecting to a 'Bluetooth Device'.

## 16. FCC COMPLIANCE INFORMATION

### FCC ID: V2R-900LEGACY

This device complies with part 15 of FCC Rules. Operation is subject to the following two conditions:

(1) This device may not cause harmful interference, and (2) this device must accept any interference received, including interference that may cause undesired operation.

Information to the user:

NOTE: This equipment has been tested and found to comply with limits for a Class B digital device, pursuant to part 15 of the FCC Rules. These limits are designed to provide reasonable protection against harmful interference in a residential installation. This equipment generates, use and can radiate radio frequency energy and, if not installed and used in accordance with the instructions, may cause harmful interference to radio communications.

However there is no guarantee that interference will not occur in a particular installation. If this equipment does cause harmful interference to radio or television reception, which can be determined by turning the equipment off and on, the user is encouraged to try the correct interference by one or more of the following measures:

- Reorient or relocate the receiving antenna.
- Increase the separation between the equipment and receiver.
- Connect the equipment into an outlet on a circuit different from that to which the receiver is connected.
- Consult the dealer or an experienced radio/TV technician for help.

### CAUTION TO USER:

Changes or modifications not expressly approved by the party responsible for compliance could void the user's authority to operate the equipment.

### CE COMPLIANCE INFORMATION

Phiaton, hereby declares that this 900 LEGACY is in compliance with the essential requirements and other relevant provisions of directive 1999/5/EC.

–

Qualcomm is a trademark of Qualcomm Incorporated, registered in the United States and other countries.

aptx is a trademark of Qualcomm Technologies International, Ltd., registered in the United States and other countries.



**PHIATON Corporation**

10231 Slater Ave., #211, Fountain Valley, CA 92708, USA

To learn more, visit our website, [www.phiaton.com](http://www.phiaton.com)

Phiaton is a trademark of Phiaton Corporation.