

Installation Instruction

WARNING

- To reduce the risk of death, personal injury or property damage from fire, electric shock, falling parts, cuts/abrasions, and other hazards read all warnings and instructions included with and on the fixture box and all fixture labels.
- Before installing, servicing, or performing routine maintenance upon this equipment, follow these general precautions.
- Commercial installation, service and maintenance of luminaires should be performed by a qualified licensed electrician.
- For the installation: If you are unsure about the installation or maintenance of the luminaires, consult a qualified licensed electrician and check your local electrical code.
- To prevent wiring damage or abrasion, do not expose wiring to edges of sheet metal or other sharp objects.
- Do not make or alter any open holes in an enclosure of wiring or electrical components during kit installation.

WARNING

- Turn off electrical power at fuse or circuit breaker box before wiring fixture to the power supply.
- Turn off the power when you perform any maintenance.
- Verify that supply voltage is correct by comparing it with the luminaire label information.
- All wiring connections should be capped with UL approved wire connectors.

CAUTION

- Avoid direct eye exposure to the light source while it is on.
- Account for small parts and destroy packing material, as these may be hazardous to children.
- Risk of burn. Disconnect power and allow fixture to cool before changing bulb or handling fixture.

NOTICE: Green ground screw provided in proper location. Do not relocate.

NOTICE: Minimum 90° supply conductors.

NOTICE: Specifications and dimensions subject to change without notice.

NOTICE: Suitable for Dry or Damp location.

General Wiring Diagram

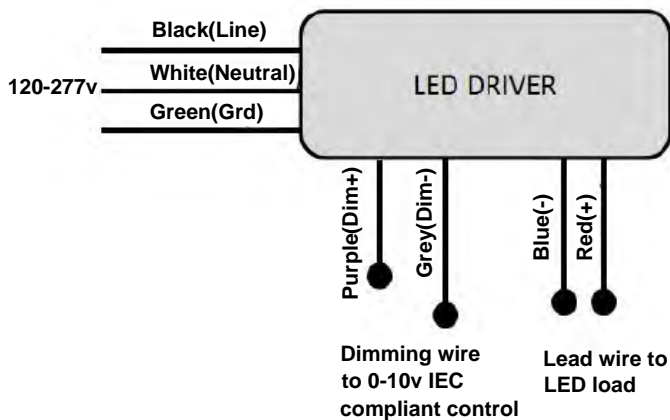

CONDOR LED HIGH BAY, MV, 0-10V DIMMING

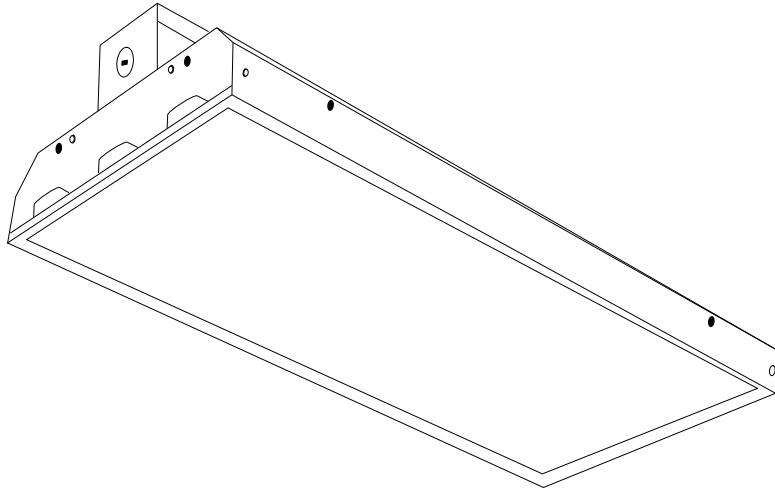

INSTALLATION INSTRUCTIONS

Please read carefully and save these instructions. Failure to do so may lead to electrical shock or fire, which may cause injury or death.

For questions, problems, or missing parts call the Customer Service line at 866-284-2638.

CAUTION

WARNING – RISK OF FIRE: Turn off the main power at the circuit breaker before installing the fixture or performing other maintenance in order to prevent possible shock.

GENERAL

All electrical connections must be in accordance with local, and national electrical codes.

Prior to installation remove all protective plastic film covering from the fixture.

Tools needed for installation: Phillips screwdriver, wire strippers, and pliers.

ASSEMBLY AND INSTALLATION

1. Remove the **screw (A)** near the **wire cover (B)** located on the back of the fixture. [Fig. 1]
2. Punch out one of the **knockouts (C)** in the **wire cover (B)**. [Fig. 1]
3. Open the **wire cover (B)** and thread the **supply wires** through the **knockout (C)**. Insert the **supply wires** into the **quick connector (D)** aligning the **black supply wire** with the **black fixture wire** and the **white supply wire** to the **white fixture wire**. [Fig. 2]
4. If the fixture will be connected to a dimmer, punch out one of the **knockouts (E)** located around the back portion of the fixture and pull the **dimming wires** out through that **knockout (E)**. [Fig. 3]
5. Place the **wire cover (B)** back onto the fixture and secure it with the **screw (A)** that was previously removed. [Fig. 1]
6. Hook the **hangers** into the **oblong holes** in the back of the fixture and through the **round holes** on the end of the fixture. [Fig. 4]

DIMMING

1. Insert the **purple dimming wire** into the **quick connector** with the **purple fixture wire**. Insert the **grey dimming wire** into the **quick connector** with the **grey fixture wire**. [Fig. 5]

For up-to-date list of compatible dimmers, look up the model number at envirolite-LED.com.

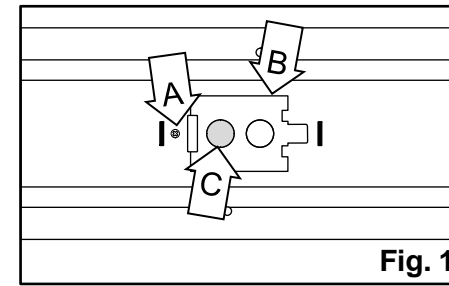

Fig. 1

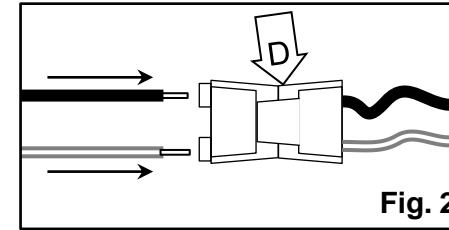

Fig. 2

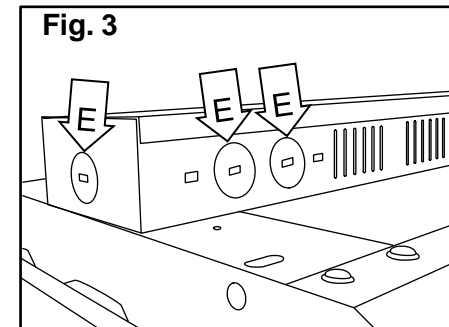

Fig. 3

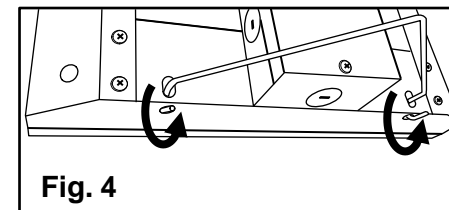

Fig. 4

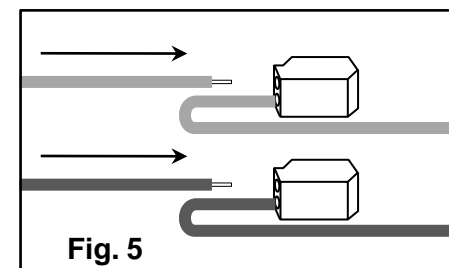

Fig. 5



Installation Instruction



A: Optional Cable Kit

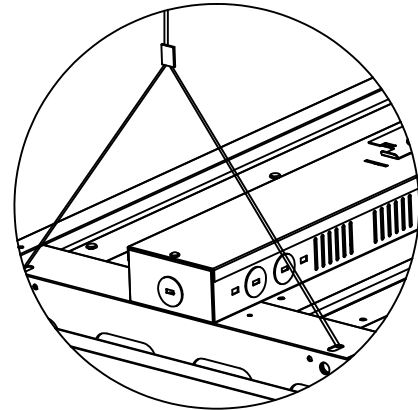
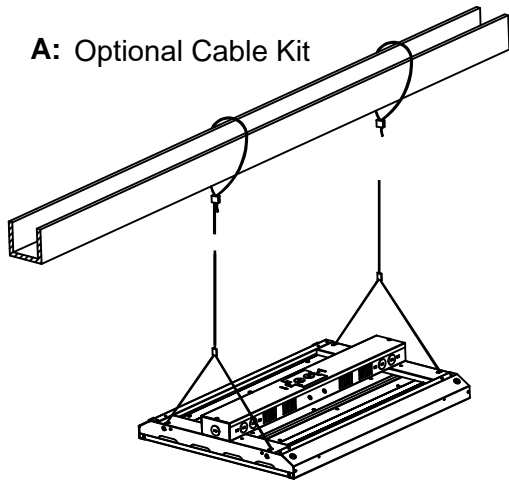

B: Optional Chain Kit

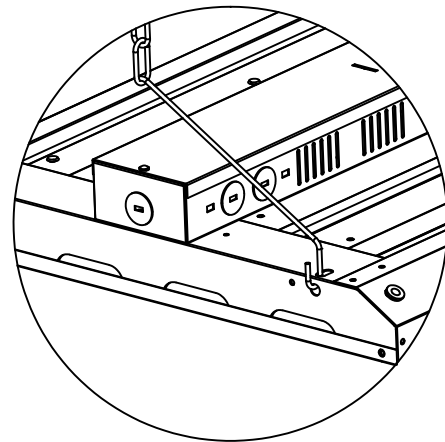
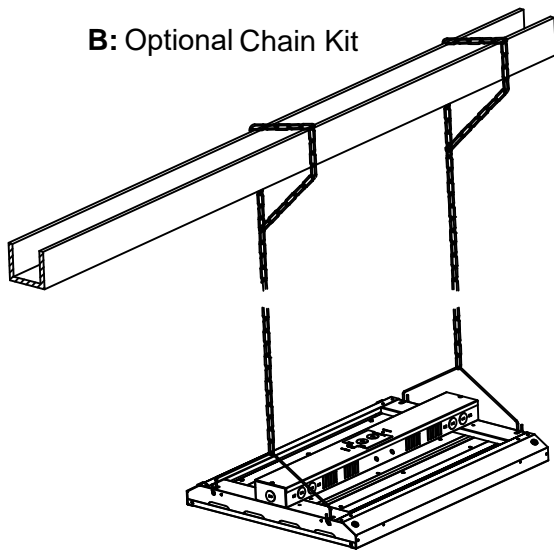

C: Wire Guards (Special Order)

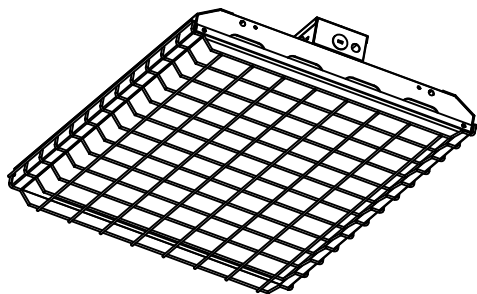

Installation Instruction



D: Optional Surface Mounting

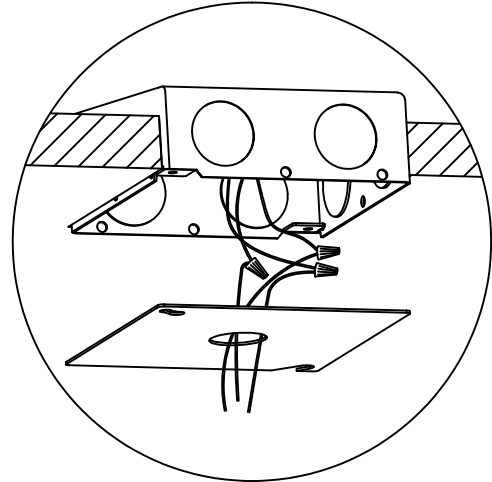
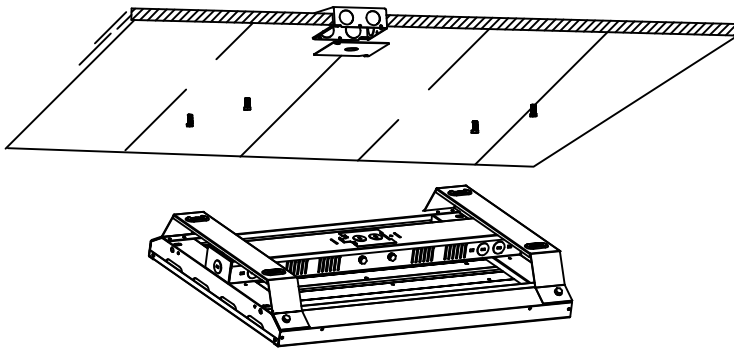

E: Optional Pendant Hanger

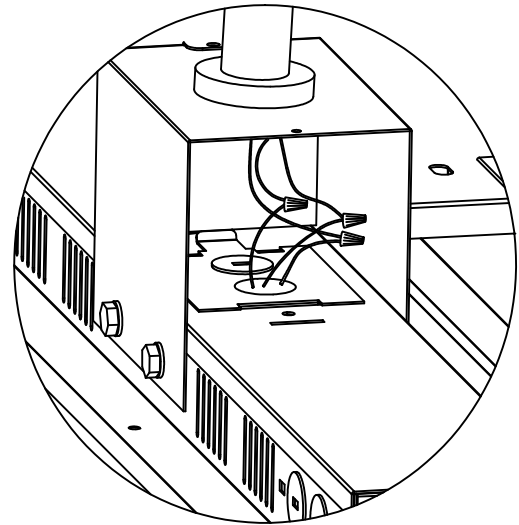
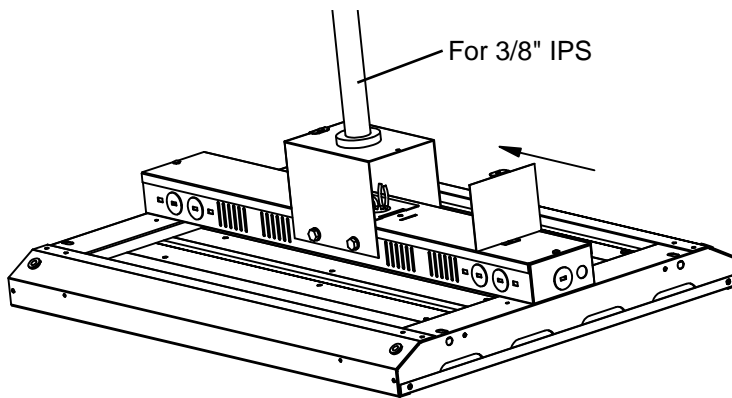

Installation Step:

Always turn off the power supply from main circuit breaker first!

- Remove the new LED fixture from packaging and inspect for any damages. Handle new LED fixture with care.
- CHAIN MOUNT EXAMPLE; Install the chain into the provided wire hanger. Secure the other end of the chain to a structure using hardware rated for the load. Install the wire hanger onto the side of the top ETLB7 LED channel. Make sure the wiring hangers are fully engaged into the side holes on the top channel.
- Connect the LED high bay wiring to line wire, black to black, white to white and green to green. Use only UL listed wiring.
**NOTE: Purple and grey lead inside the driver compartment are 0-10V (low voltage) dimming leads. Connect to dimming low voltage wiring only.
- Clean all residues/fingerprints from the new LED high bay and lens. Double check all hanging hardware before moving onto the next installation.