



INDUSTRIAL AND COMMERCIAL
LIGHTING MFR SINCE 2003

PROJECT NAME: _____

CATALOG NUMBER: _____

NOTES: _____

FIXTURE SCHEDULE: _____

Premium Quarter Sphere Wall Pack



This premium quarter sphere wall pack is designed to be both practical and elegant. The full cutoff style projects the light down, reducing light spread. The die-cast aluminum body features a UV stabilized powder coat finish, and the fixture is wet location rated for mounting outside along the sides of buildings, schools, garages, and many other structures.

The wall pack is wattage selectable (15W / 30W / 50W / 72W) in the field, giving greater flexibility in application and lumen output.

Includes mounting plate with integrated leveling bubble.

Features:

- Wattage: 15W / 30W / 50W / 72W
- Voltage: 120-277
- CCT: 4000K or 5000K
- CRI: 70+
- Lumens:
 - 15W = 1755
 - 30W = 3510
 - 50W = 5850
 - 72W = 8424
- Finish: Bronze
- Listings: cULus, Wet Location Rated, RoHS
- Warranty: 5 years



Model	Wattage Selectable	CCT	Dimming/Multi-Volt
WLPQS	-WT= Wattage Selectable (15W/30W/50W/72W)	-40 = 4000K	-DMV
WLPQS		-50 = 5000K	

Lighting Supplier Since 2003



WAREHOUSE-LIGHTING.COM

Warehouse-Lighting.com
2750 South 163rd St
New Berlin, WI 53151

Warehouse-Lighting.com
Phone: 888-454-4480
info@warehouse-lighting.com



INDUSTRIAL AND COMMERCIAL
LIGHTING MFR SINCE 2003

Dimensions:

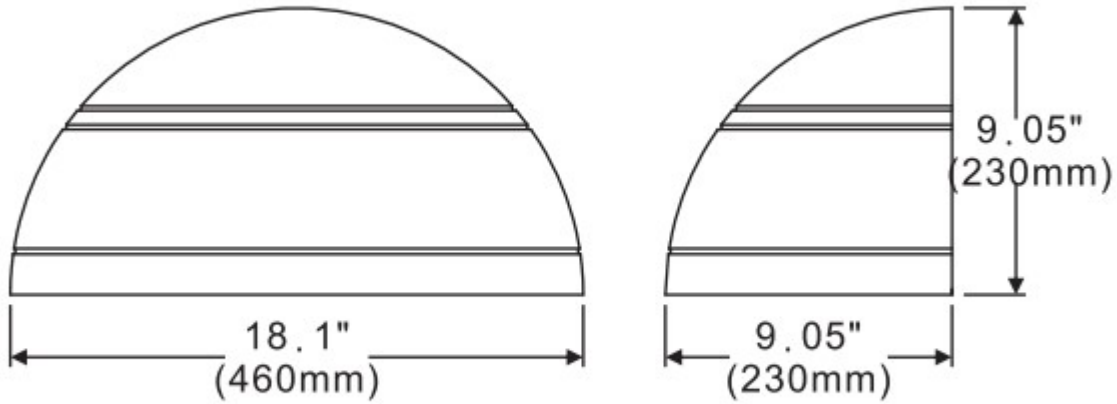

Photometrics:

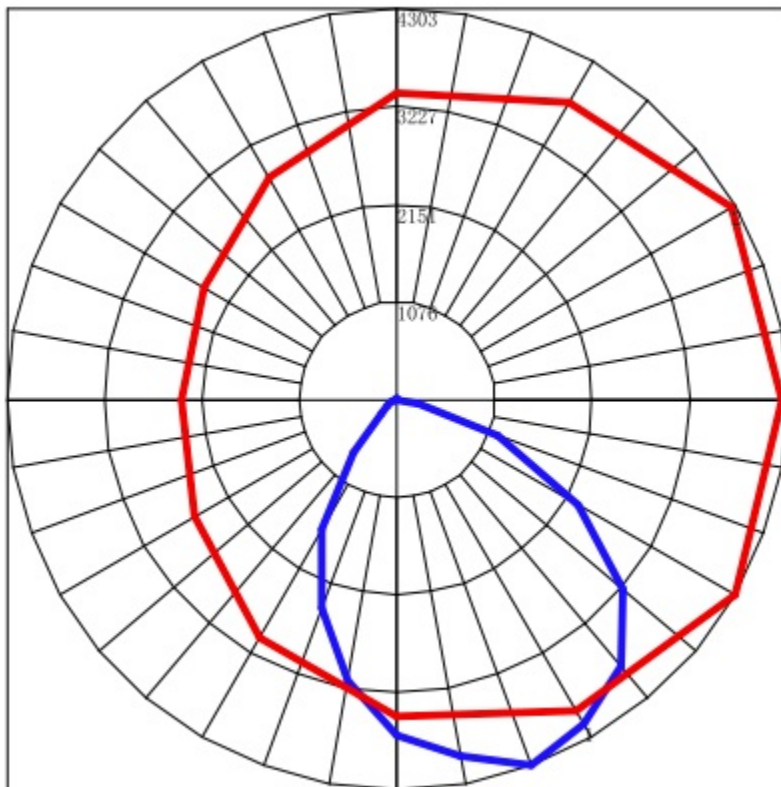

Lighting Supplier Since 2003



WAREHOUSE-LIGHTING.COM

Warehouse-Lighting.com
2750 South 163rd St
New Berlin, WI 53151

Warehouse-Lighting.com
Phone: 888-454-4480
info@warehouse-lighting.com