



Item#: **WL83722**  
**LED SPEC-SELECT™ DUSK TO DAWN**  
 OUTDOOR POLE/ARM-MOUNTED AREA AND  
 ROADWAY LUMINAIRES

**FEATURES**

Spec-Select™ Dusk to Dawn feature adjustable wattage and color temperature for the perfect balance of light in any application.

- Corrosion resistant; cold forged aluminum housing.
- Built-in photocell
- Mounts directly to wall or with mounting arm (*Not included, sold separately*).

**APPLICATION**

Ideal for general area lighting, entry ways, pathways, loading docks, farmyards and building security.

**ELECTRICAL**

Wattage	35W / 50W / 65W
Voltage	120-277V
Current	0.65A
Power Factor	0.9
Total Harmonic Distortion (THD)	15

**LIGHTING PERFORMANCE**

Lumens	4375 / 6250 / 8125
Lumens Per Watt (LPW)	125
Color Temperature (CCT)	3000K / 4000K / 5000K
Color Rendering (CRI)	70
R9 (Red Value)	--
R13 (Skin Tones)	71 / 74 / 71
Beam Angle	140°
Light Distribution	Type VS
BUG Rating (Backlight, Uplight, and Glare)	B2 - U2 - G1
Dimmable Lighting Control	<i>Dimmable</i> 0-10V, Range 10% - 100%

**ENVIRONMENT**

Operating Temperature	-4° ~ 113°F
Suitable Location	<b>WET</b>
Ingress Protection Rating	IP66

**LIFESPAN**

Average Life (Hours)	50,000
Warranty (Years)	<b>5</b>

**COMPONENTS**

LED Light Source	SMD 2835
Driver (Non-Replaceable)	Internal

**CONSTRUCTION**

Housing	Aluminum / PC Lens
Base / Power Supply	Hard Wired
Finish	Bronze

**QUALIFICATIONS**

Model Number	SSDTD-35/50/65W-30/40/50K-MV
--------------	------------------------------



Visit [www.designlights.org/search](http://www.designlights.org/search) to confirm qualification. • Published lumens on LED products are approximate and may vary slightly. • Specifications are subject to change without notice.

Item#: **WL83722**  
**LED SPEC-SELECT™ DUSK TO DAWN**

<b>DIMENSIONS</b> (Inches)	
Length	12.6"
Width	9.1"
Height	4.4"
Net Weight (Lbs)	3.3

<b>SUPPORTING DOCUMENTS</b> (Grey = not available at this time.)	
Product Sheet	VIEW
Install Instructions	VIEW
Photometrics	VIEW
IES Download from Web Item	VIEW
LM79	VIEW
LM80	VIEW

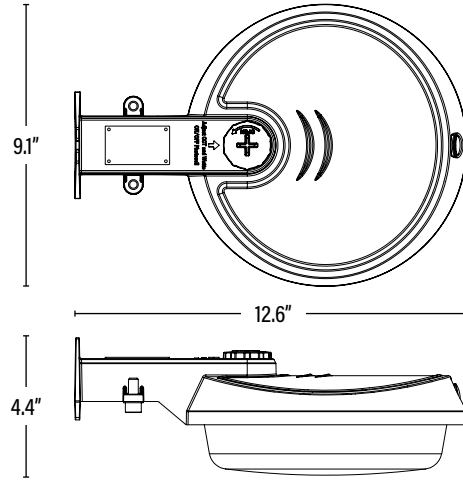

<b>PACKAGING</b>		<b>UPC</b>	<b>DIMENSIONS</b> (LxWxH)	<b>GROSS WEIGHT</b> (Lbs)
Master Carton	1	811768025651	14" x 10.6" x 5.3"	4.9
Country of Origin	China			
HS Tariff	9405.11.6020			

**ORDERING** Qualification Model # SSDTD-35/50/65W-30/40/50K-MV

<b>ITEM#</b>	<b>DESCRIPTION</b>	<b>CASE</b>
WL83722	LED SPEC-SELECT™ DUSK TO DAWN/35-50-65W/30-50K/DIMM/120-277V/BRZ/PHOTO CELL - DLC®	1

**ACCESSORIES**

WL83720	MOUNTING ARM ONLY FOR LED SPEC-SELECT™ DUSK TO DAWN LIGHT - SUPERIOR LIFE®	25
---------	--	----

ITEM INFORMATION