



WAREHOUSE-LIGHTING.COM

Project	
Notes	
Type	Date
Cat. No.	

SCB G3™ Series

Slim-Profile Circular LED High Bay

DESCRIPTION

The SCB G3™ Series Slim-Profile Circular High Bay delivers industry-leading performance with a durable, heavy-duty construction. Superior performance, ultra high-efficacy and premium quality provides a robust solution for high ceiling applications, especially warehouse spaces. Delivering high output, quality light and low energy consumption can improve warehouse safety and productivity, lower maintenance cost, and reducing operating costs.

APPLICATIONS

Provides high output illumination for various commercial industrial applications with high ceilings: warehouse, manufacturing, gymnasiums, cold-storage, wash-down areas



SCB Series

13L	100W
19L	150W
25L	200W
30L	240W

Specification Features

Construction

Rugged, die-cast housing with advanced thermal management system ensures reliability and durability. Weather-proof, gasketed driver compartment protects electronics against environmental elements. IP65, wet location.

Optical System

Diffuser lens reduces glare and improves occupant working conditions while maintaining high efficiency emission.

Certification

UL Listed. Wet location rated. ETL Sanitation Listed, conforms to NSF 2 standard

Warranty

7-year Limited Warranty. See warranty documentation for more information.

Electrical

Luminaire utilizes high-efficacy LED packages maintained at cool temperatures for long life, high efficacy. Reliable driver features continuous dimming. Universal voltage (120-277V) for convenient installation. Comes equipped standard with 10' white STOW cord.

Installation / Mounting

Single point mount for hook, pendant, or stem mounting

Controls / Dimming

Continuous dimming (1-10V) comes standard. Suitable for use with dimmers, sensors, daylight harvesting and other control strategies to achieve deeper energy-savings and code compliance.

Rated Life 75,000 hours
 Limited Warranty 7-years
 Efficacy Up to 143 LPW
 Continuous Dimming



Ordering Information

Example: SCB-19L/50K G3 ECO

SCB	19L	50	[Blank]	[Blank]	Options
Series	Nominal Lumen Package	Color Temp	Input Voltage	Dimming	Controls
SCB	13L 13,000 lm (100W)	50K 5000K	Blank	Blank	OSDL/IR Occ Sensor w/ Daylight
Slim Circular	19L 19,000 lm (150W)		120V-277V	1-10V	OSDL/BT Wireless Bluetooth
High Bay	25L 25,000 lm (200W)			Continuous Dimming	Occupancy Sensor
	30L 30,000 lm (240W)				OSDL/BTEZ-B Occupancy Sensor
					Accessories
					EM BBU
					See Page 3 for details



WAREHOUSE-LIGHTING.COM

Warehouse-Lighting.com
 2750 South 163rd St New
 Berlin, WI 53151

warehouse-lighting.com
 Phone: (888) 571-7878
 info@warehouse-lighting.com

Performance Summary

Input Voltage	120V-277V
Input Frequency	50/60 Hz
Rated Wattage	See Performance Table
Delivered Lumens	See Performance Table
Efficacy	143 LPW (typ.)
CRI	80
Available CCT ¹	5000K
Color Consistency ²	5-step MacAdam Ellipse
Rated Life	75,000 hours
L70 ³	> 72,000 hours or > 45,000
Power Factor	> 0.9
THD	< 20%
Dimming	1-10V Continuous (10-100%)
Operating Temp.	-40°C to 50°C



Multi-level Occupancy Sensor
PIR Occupancy Sensor with Daylight function
Code-compliance



Performance Data

Catalog No.	Wattage (W)	5000K	
		Delivered Lumens (lm)	Efficacy (lm/W)
SCB-13L/50K G3 ECO	97.48	14,096	144.6
SCB-19L/50K G3 ECO	146.8	20,513	139.73
SCB-25L/50K G3 ECO	198.7	28,580	143.8
SCB-30L/50K G3 ECO	234.8	33,684	143.46

DLC QPL Data

QPL Model No.	Product ID	Technical Req.	Classification	Primary Use
SCB-13L/40K G3 ECO	PLS1EEGTMENG	5	Premium	High-Bay Luminaires for Commercial and Industrial Buildings
SCB-13L/50K G3 ECO	PL0D2RITQPJA	5	Premium	High-Bay Luminaires for Commercial and Industrial Buildings
SCB-13L/57K G3 ECO	PLWPTNUTP8S1	5	Premium	High-Bay Luminaires for Commercial and Industrial Buildings
SCB-19L/40K G3 ECO	PL518CB1SWZ9	5	Premium	High-Bay Luminaires for Commercial and Industrial Buildings
SCB-19L/50K G3 ECO	PLDMWIS8UVT4	5	Premium	High-Bay Luminaires for Commercial and Industrial Buildings
SCB-19L/57K G3 ECO	PLTSHN1GEDHS	5	Premium	High-Bay Luminaires for Commercial and Industrial Buildings
SCB-25L/40K G3 ECO	PLXGA371B4WC	5	Premium	High-Bay Luminaires for Commercial and Industrial Buildings
SCB-25L/50K G3 ECO	PLS2R61BS4BK	5	Premium	High-Bay Luminaires for Commercial and Industrial Buildings
SCB-25L/57K G3 ECO	PLZDHYDSA82L	5	Premium	High-Bay Luminaires for Commercial and Industrial Buildings
SCB-30L/40K G3 ECO	PLQX3W6VL29J	5	Premium	High-Bay Luminaires for Commercial and Industrial Buildings
SCB-30L/50K G3 ECO	PLUKTZOTQ1CH	5	Premium	High-Bay Luminaires for Commercial and Industrial Buildings
SCB-30L/57K G3 ECO	PLI1CJLUBP5E	5	Premium	High-Bay Luminaires for Commercial and Industrial Buildings

NOTES:

- ¹ Quick ship: 5000K. Other CCTs may require a lead time or be special order
- ² Typical color consistency. May vary or be changed.
- ³ L70 hours calculated based on LED package manufacturer LM80 report and ISTMT report of LED in luminaire. Stated values are for select catalog numbers. Contact manufacturer for detailed information

Product Dimensions

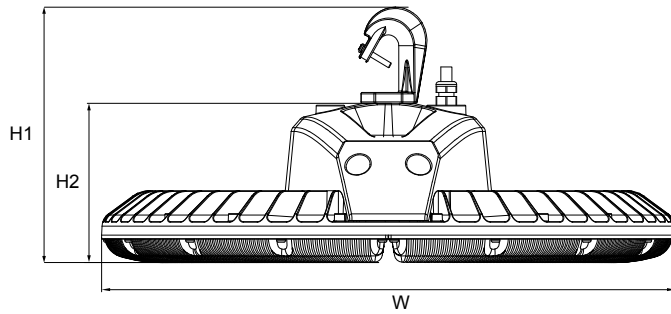

Product	Height (H1)	Height 2 (H2)	Width (W)
SCB-13L G3 ECO	6.97" (177mm)	4.16" (105mm)	12.6" (320mm)
SCB-19L G3 ECO	6.97" (177mm)	4.16" (105mm)	12.6" (320mm)
SCB-25L G3 ECO	7.32" (185mm)	4.52" (114mm)	14.17" (360mm)
SCB-30L G3 ECO	7.47" (189mm)	4.66" (118mm)	17.52" (445mm)

Emergency Battery Backup

Item No.: EM-UFO-V200-UNV-H-FI-30

For Field Install UFO EM LED Driver, 30W max., 120V-277V input, min. 90 min, dual J-Box with eyebolts

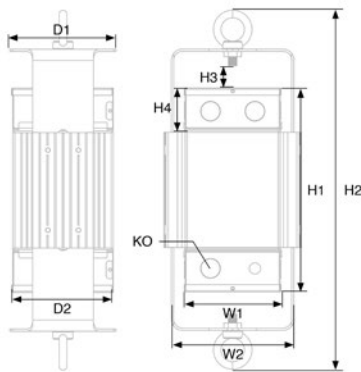

Enclosure (in. ±1)	EM Driver (in.)
Width (W1)	4.21"
Width (W2)	6.10"
Height (H1)	8.54"
Height (H2)	15.94"
Height (H3)	0.98"
Depth (D1)	4.69"
J-Box Size	
Width (W1)	4.21"
Height (H4)	1.55"
Depth (D2)	4.69"
Knock Out (KO)	1/2 Trade Size (0.85")



Control Pre-Commissioning

Example: SCB-19L/50K G3 ECO-OSDL/IR

L2	10H	30M	10M	3L
Lens / Coverage	High Level	Low Level	Time Delay	Cut-Off
L2 8' height (60' dia.)	9H 100%	1L 10%	30S 30 sec.	#M 1-59 min.
L3 20' height (40' dia.)	8H 80%	2L 20%	#M 1-30 min.	#H 1-5 hrs.
L7 40' height (100' dia.)	7H 70%	3L 30%	# = enter no. of minutes from 1 to 30 min.	0 Disabled
	6H 60%	4L 40%		# = enter no. of minutes or hours
	5H 50%	5L 50%		
		6L 60%		
		7L 70%		

High Level When the sensor detects motion the dimming control output ramps up to the selected HIGH light level.

Low Level After the sensor stops detecting motion and the time delay expires the dimming control output fades down to the selected LOW light level.

Time Delay The selected time period that must elapse after the last time the sensor detects motion for the electric lights to fade to LOW mode

Cut-Off The time period that must elapse after the lights fade to LOW mode and the sensor detects no motion for the electric lights to turn OFF.

Ramp Up Time period for light level to increase from LOW to HIGH.

Fade Down Time period for light level to decrease from HIGH to LOW.