

PFS80Q

L70
25°C

362,000 Hours

EasyLED Reveal Open Large Square Post Top

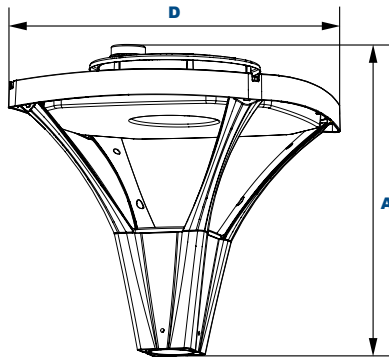

Dimensions

Width (D)	21 3/4" (551mm)
Height (A)	23 1/4" (589mm)

The LEPG PFS80Q Reveal Architectural Open Large Square Post Top is available in a Type V distribution with two lens options designed to replace HID lighting systems up to 1000w MH or HPS. The fixture mounts to a pole top tenon. Typical area lighting applications include parking areas, walkways, and street lighting applications. Mounting heights of 12 to 30 feet can be used based on light level and uniformity requirements.

Specifications and Features:

Housing:

Die Cast Aluminum Housing, Integral Heat Sinking. Photocell Adaptable.

Listing & Ratings:

CSA: Listed for Wet Locations, ANSI/UL 1598, 8750; IP66 Sealed LED Compartment.

Finish:

Black Powdercoat Finish Over a Chromate Conversion Coating. Custom Colors Available Upon Request.

Lens:

Clear Polycarbonate or SoftLED LumaLens Opal Polycarbonate Vandal-Resistant Array Lens to Seal LED Array

Mounting Options:

Accommodates "P3" 2 1/8" O.D. x 3" Tenons

EasyLED LED:

Aluminum Boards

Wattage:

Array: 176w, System: 190.2w; (400-1000w HID Equivalent)

Driver:

Electronic Driver, 120-277V, 50/60Hz or 347-480V, 50/60Hz; Less Than 20% THD and PF>0.90. Standard Internal Surge Protection 6kV. 0-10V Dimming Standard for a Dimming Range of 100% to 10%; Dimming Source Current is 150 Microamps.

Controls:

Fixtures Ordered with Factory-Installed Photocell or Motion Sensor Controls are Internally Wired for Switching and/or 1-10V Dimming Within the Housing. Remote Direct Wired Interface of 1-10V Dimming is Not Implied and May Not Be Available, Please Consult Factory. Fixtures are Tested with LEPG Controls and May Not Function Properly With Controls Supplied By Others. Fixtures are NOT Designed for Use with Line Voltage Dimmers.

Warranty:

5-Year Warranty for -40°C to +50°C Environment.

See Page 2 for Projected Lumen Maintenance Table.

Order Information Example:

PFS80QF1X176U5KCBSP

PFS80Q	F	1X176		5K			
Model	Optics	Wattage	Driver	CCT	Lens	Color	Options
PFS80Q= EasyLED Reveal Open Large Square Post Top	F=Type V	1X176=176w	U=120-277V H=347-480V	5K=5000K	C=Clear Polycarbonate Array Lens L=SoftLED LumaLens Opal Polycarbonate Array Lens	B=Black C=Custom (Consult Factory)	SF=Single Fuse DF=Double Fuse SP=Surge Protection S2=Microwave Sensor with Dimming for Mounting Heights of 8 to 40' R3=3-Pin Twist Lock Photocell Receptacle R7=7-Pin ANSI C136.41—2013 Twist Lock Photocell Receptacle

Project Information:

Project Name: _____ Fixture Type: _____

Complete Catalog #: _____ Date: _____

Comments: _____

Certification & Listings:



DesignLights Consortium™
Manufacturer: QSSI

Not all product variations listed on this page are DLC qualified. To ensure that a specific model is qualified, visit www.designlights.org/search.



Specifications subject to change without notice. Rev. 082218

PFS80Q L70 25°C 362,000 Hours

EasyLED Reveal Open Large Square Post Top

Accessories & Replacement Parts:



Accessories (Order Separately, Field Installed)

P18131	Twist Lock Non-Shorting (Open) Cap Disconnects Service to Fixture for Temporary or Permanent Disabling (Fixture Always Off). IP65, 480V Maximum.
P18132	Twist Lock Shorting Cap Provides Fixed Service to Fixture (Fixture Always on). IP65, Rated Load 7200w Tungsten.
P18140	110-120VAC Instant Twist Lock Photocell
P18142	105-287VAC Instant Twist Lock Photocell
P18150	120VAC Time Delay Twist Lock Photocell
P18152	277VAC Time Delay Twist Lock Photocell
P18156	120-277VAC Universal Twist Lock Photocell

Replacement Parts (Order Separately, Field Installed)

PFS80ALL	SoftLED LumaLens Opal Polycarbonate Array Lens
P17117	Internal Microwave Sensor with Dimming for Mounting Heights of 8 to 40'. 120-277VAC, 50/60Hz

Sensors Not available for 480V.

Photometric Data

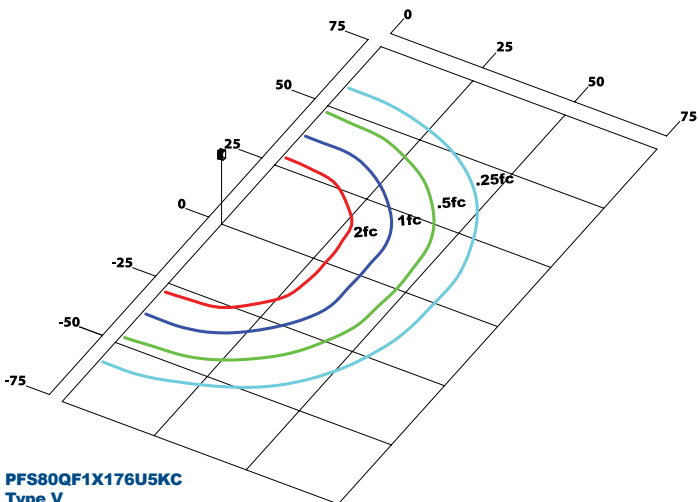

PFS80QF1X176U5KC
Type V
Grid in MH
MH=25 Feet

EPA (Effective Projected Area)

EPA (Sq. Ft.)	Weight (Lbs.)
1.70	32 Lbs

Photometric Performance

LED Board Watts	Drive Current (mA)	Input Watts	Optics	5000 CCT 80 CRI			B	U	G
				Lumens	LPW				
EasyLED 176w	525	190	Type V Clear	19,509	103	4	2	2	
			Type V Opal	16,680	88	3	2	2	

Projected Lumen Maintenance

Data shown for 5000 CCT			Compare to MH			
TM-21-11	Input Watts	Initial	25,000 Hrs	50,000 Hrs	100,000 Hrs	Calculated L70@ 25°C
L70 Lumen Maintenance @ 25°C / 77°F	190	1.00	0.98	0.96	0.92	362,000
TM-21-11	Input Watts	Initial	25,000 Hrs	50,000 Hrs	100,000 Hrs	Calculated L70@ 50°C
L70 Lumen Maintenance @ 50°C / 122°F	190	1.00	0.96	0.92	0.84	183,000
TM-21-11	Input Watts	Initial	25,000 Hrs	50,000 Hrs	100,000 Hrs	Calculated L80@ 40°C
L80 Lumen Maintenance @ 40°C / 104°F	190	1.00	0.97	0.94	0.88	167,000

NOTES:
1. Projected per IESNA TM-21-11. Data references the extrapolated performance projections for the 525mA base model in a 25°C ambient, based on 10,000 hours of LED testing per IESNA LM-80-08.
2. Compare to MH box indicates suggested Light Loss Factor (LLF) to be used when comparing to Metal Halide (MH) systems.

Specifications subject to change without notice. Rev. 082718