



LED Jelly Jar Light



Date:..... Location:

Product:..... Project:.....

Quantity:..... Catalog#

FEATURES

- UL cUL certificate.
- IP65, input voltage 120-277VAC
- No UV or IR in the beam.
- Easy to install and operate.
- Energy saving, long lifespan.
- Light is soft and uniform, safe to eyes.
- Instant start, NO humming.
- Green and eco-friendly without mercury

SUITABLE APPLICATIONS

- Garage, bathroom and attic ;
- Basement, lobby, corridor
- Restaurant, bar and country lighting, etc.



CONSTRUCTION:

Heavy die-cast aluminum alloy housing with silver powder-coated finish. Tempered Glass lens and steel wrap cover

ELECTRICAL:

Available as 120-277V input. -30°C to 45°C.

OPTICAL SYSTEM:

Lumileds 2835LED chips. High quality tempered glass optics. 160° beam angle.

INSTALLATION&MOUNTING:

Angle-adjustable U Bracket mount for wall or square pole mounting.

WARRANTY:

5-year limited warranty. Actual performance may differ as a result of end-user environment and application.

PERFORMANCE

Model NO	Power Factor	Wattage	Voltage/Current Input		Light Efficiency	Kelvin Options
			120V	277V		
AST-LJ01-21WBMUSA1-ab	0.9	21W	0.17A	0.07A	120LM/W	5000K

LED Jelly Jar Light

Electric Characteristic

Specification/Model	AST-LJ01-21WBMUSA1-ab
LED Driver	Brand
Input power	21W
Lumens output	2520LM
Efficiency	120LM/W
CRI	>80
Color Temperature	50K
Input voltage	120-277V/AC
Light distribution type	160D
Working temperature	-30+45°C
Junction temperature	<75°C
lamps efficiency	≥90%
Certificate	UL CUL DLC
Equivalent	40-150W MH/HPS

DIMENSION

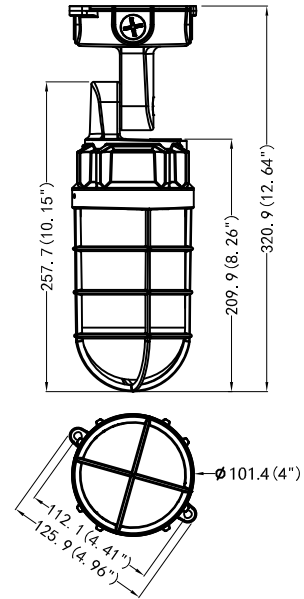

DISTRIBUTION DIAGRAM

AST-LJ01-21WBMUSA1-ab

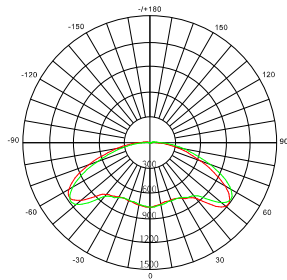

AVERAGE BEAM ANGLE[50%]:160°

UNIT:CD
 Test Number:AST-LJ01-21WBMUSA1-ab C0/180,159.5
 Lumens:2520LM C30/210,160.5
 Test Number:21W C60/240,158.9
 Test Number:5000K C90/270,161.1

LED Jelly Jar Light

► Installation Instruction

Cautions:

1. Do not use any electric generator to test the LED fixture.
2. Please abide by related country, regional and local law and regulations when installing this fixture.
3. Please turn off the power before installation or maintenance.
4. Proper earth grounding is required to ensure safety.

Notice:

1. To avoid possibility of electrical shock or fire, the installation personnel must have professional electric knowledge.
2. Please wear gloves to avoid injury before installation.
3. If any smoke or spark of the wire happened, please turn off the power immediately and notify relevant personnel.

Attention:

1. Please check if there is any damage during shipping. If so, please contact manufacturer timely.
2. Please read the installation instruction carefully to check whether all the accessories are complete. After confirmation, install the fixture according to installation steps.

Wiring Diagram & Instruction:

Wire and install the fixture as follows:

Step 1: Unscrew the driver box cover, as shown in Figure (1)

Step 2: Open the cover, there are five electronic lines, L, N, G, Dim+, Dim-

Step 3: Unscrew the 1/2" NPT nut, install suitable conduit to the conduit opening, pull the wire through the conduit hole and connect it to the terminal block (Figure 2); Wire connected to terminal block should be Aluminum or Copper Conductors. See label at the terminal block for wiring.

Step 4: Lock the driver box cover with screws. (Figure 3).

Step 5: After installation, please ensure all the wiring is in accordance with local connection standard.

Note:

All the conduit openings must be closed by conduit or NPT nut. When ever installing the NPT nut or conduit during installation or maintenance, please ensure silicone gel is added around the NPT nut.

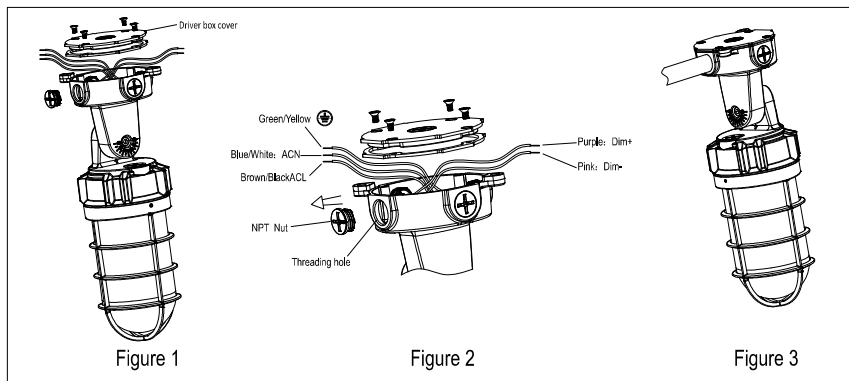

Instructions for CCT select and Dimming function:

1. CCT and dimming function is optional for the fixture, and choose not to use the function if it's not required.

2. Ring instruction for fixture with CCT adjustment function (Figure 4).

Step 1: As shown in the figure below (Figure 4-1), adjust the mounting bracket to prevent interference when unscrewing the gasketed cap.

Step 2: Unscrew the gasketed cap from the fixture as shown in the images below.

Step 3: Adjust the CCT or wattage to the described setting (Figure 4-2).

Step 4: Screw on gasketed cap.

3. Ring instruction for fixture with dimming function.

Step 1: Unscrew the driver box cover, as shown in Figure (1);

Step 2: Wire according to purple and pink dimming as shown in Figure (2).

LED Jelly Jar Light

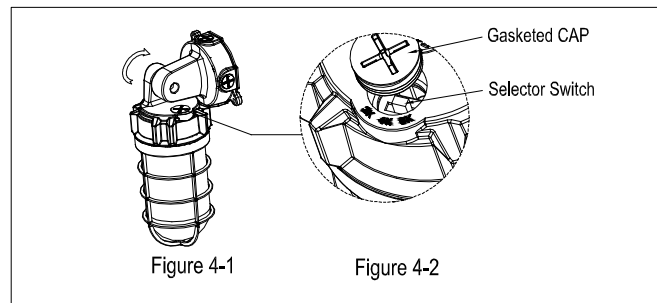

Installation Methods:

(Choose the appropriate installation method as needed)

CM:Ceiling mount

1. Make marks on the walls, and then drill holes on the marks (Figure 5).
2. Use a hammer to put the expansion screws into the holes (Figure 6).
3. The holes on the bracket should be aligned with the expansion screws (Figure 7).
4. Tighten the nut of the screws (Figure 8).
5. Wiring according to the instructions on the first and second pages.
6. After installation, please wire in accordance with local wiring standard, and make sure to take good waterproof measures at the joint of conduit. Users can adjust degree to left or right from vertical downward direction by adjusting the screw on the bracket. (Figure 9).

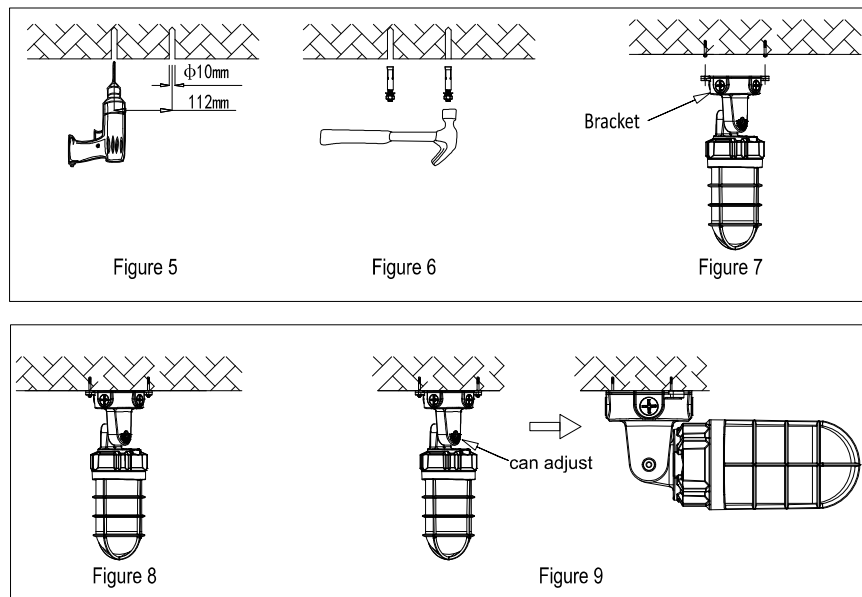

FM:bracket wall mounting:

1. Use a chalk or sharp tool to mark signs on the top of the ceiling, then drill holes on the signs by electric drill (Figure 10).
2. Use a hammer to put the expansion screws into the holes (Figure 11).
3. The holes on the bracket should be aligned with the expansion screws, then push the fixture to one side (Figure 11).
4. Tighten the nut of the screws (Figure 12).
5. Wiring according to the instructions on the first and second pages.
6. After installation, please wire in accordance with local wiring standard, and make sure to take good waterproof measures at the joint of conduit.

LED Jelly Jar Light

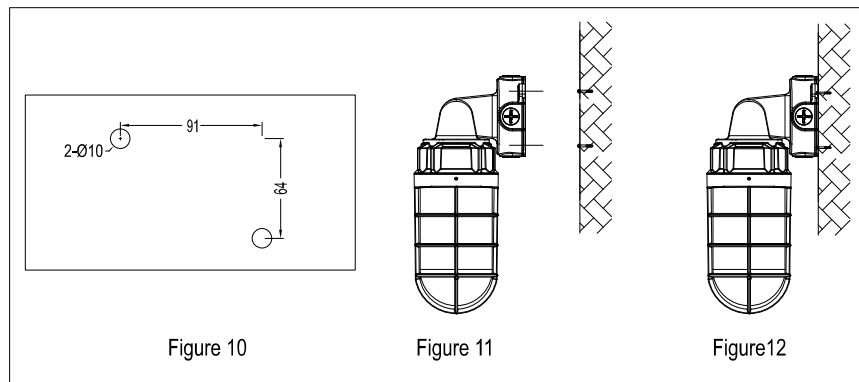

TM: Threaded pipe mounting

1. Unscrew the gasketed cap from the fixture (Figure 13).
2. Pass the wire in the threaded pipe through the hole and connect to the terminal accordingly (Figure 14).
3. After the wiring is completed, put the threaded pipe into the hole, turn it clockwise to tighten it. (Figure 14).
4. Lock the driver box cover with screws (Figure 15).
5. After installation, please wire in accordance with local connection standard, and make sure to take good waterproof measures at the joint of conduit.

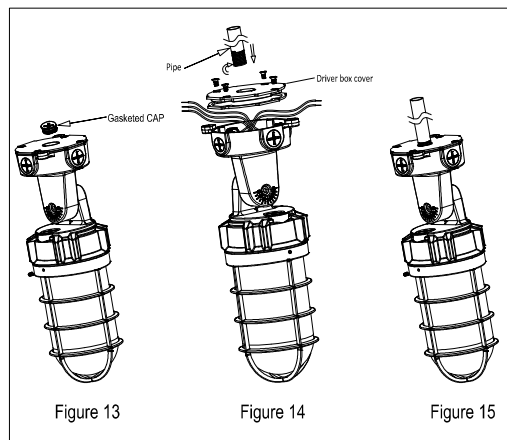

Install with outlet box:

1. Turn off the power (Figure 16);
2. Loosen the 4 screws and remove the 1/2 end cap (Figure 17);
3. Attach the EVA cotton pad to box cover, and thread the wire through the bottom holes (Figure 18);
4. Connect the L, N, and G wires to the power supply; Lock the box cover on the bracket with screws (Figure 19);
5. Lock the box on the mounting seat with screws (Figure 20);
6. Make sure the installation is complete before turning on the power switch.

