

KT-BPLED40PS-22B-8CSA-VDIM /FC2

BACKLIT LED PANEL LIGHT

DESCRIPTION

2x2 LED Panel feat. Power Select & Color Select with Embedded Smartloop PIR Sensor | 40/30/20W | 120-277V Input | 3500/4000/5000K | 0-10V Dimming | Backlit Design



5 YEAR
WARRANTY

PRODUCT FEATURES

- Keystone Power Select technology (40/30/20W). Adjust power between 40/30/20W, changing lumen output to set high end trim.
- Keystone Color Select Technology. Adjustable CCT (3500/4000/5000K)
- Features integrated Keystone SmartLoop Bluetooth™ mesh wireless sensor controller.
- The sensor controller may be used “out of the box” as a stand alone sensor (pre-commissioned, see page 2 for details); or may be commissioned using the SmartLoop app to add advanced functions such as zoning, high end trim, configure occupancy/vacancy behavior, create scenes, and set schedules.
- To learn more about the Keystone SmartLoop System, visit <http://www.keystonetech.com/smartloop>
- Fits all standard T-grid ceilings. Surface and suspension mount options

* For use in non-fire rated installations only

- available (purchased separately)*
- Construction features precise optical lenses over each individual LED offering optimal light diffusion and consistent surface illumination
- Compatible with Keystone SmartSafe LED emergency backup
- Powered by Keystone 0-10V dimmable LED driver with built in junction box with (4) available 1/2” K/O’s
- Operating temp range: -20°C/-4°F to 40°C/104°F
- Suitable for damp locations
- Nearly 70% energy saving savings compared to traditional fluorescent troffers without controls

PERFORMANCE SPECIFICATIONS

Catalog Number	Wattage	CCT	Lumen Output	Efficacy	Input Voltage	CRI	Power Factor	Lifetime
KT-BPLED40PS-22B-8CSA-VDIM /FC2*	40W	3500K	4,400	110 lm/W	120-277V	>80	>0.9	50,000 Hours
		4000K	4,500	113 lm/W				
		5000K	4,450	111 lm/W				
	30W	3500K	3,400	111 lm/W				
		4000K	3,500	117 lm/W				
		5000K	3,450	115 lm/W				
	20W	3500K	2,400	111 lm/W				
		4000K	2,500	125 lm/W				
		5000K	2,450	123 lm/W				

ONE CATALOG NUMBER WITH 9 DIFFERENT OPTIONS

* Preset to highest lumen output (40W / 5000K)

* Color Uniformity: CCT (Correlated Color Temperature) range as per guidelines outlined in ANSI C78.377-2017.

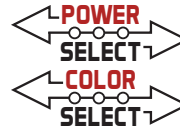

KT-BPLED40PS-22B-8CSA-VDIM /FC2

BACKLIT LED PANEL LIGHT

BUILT-IN FEATURES

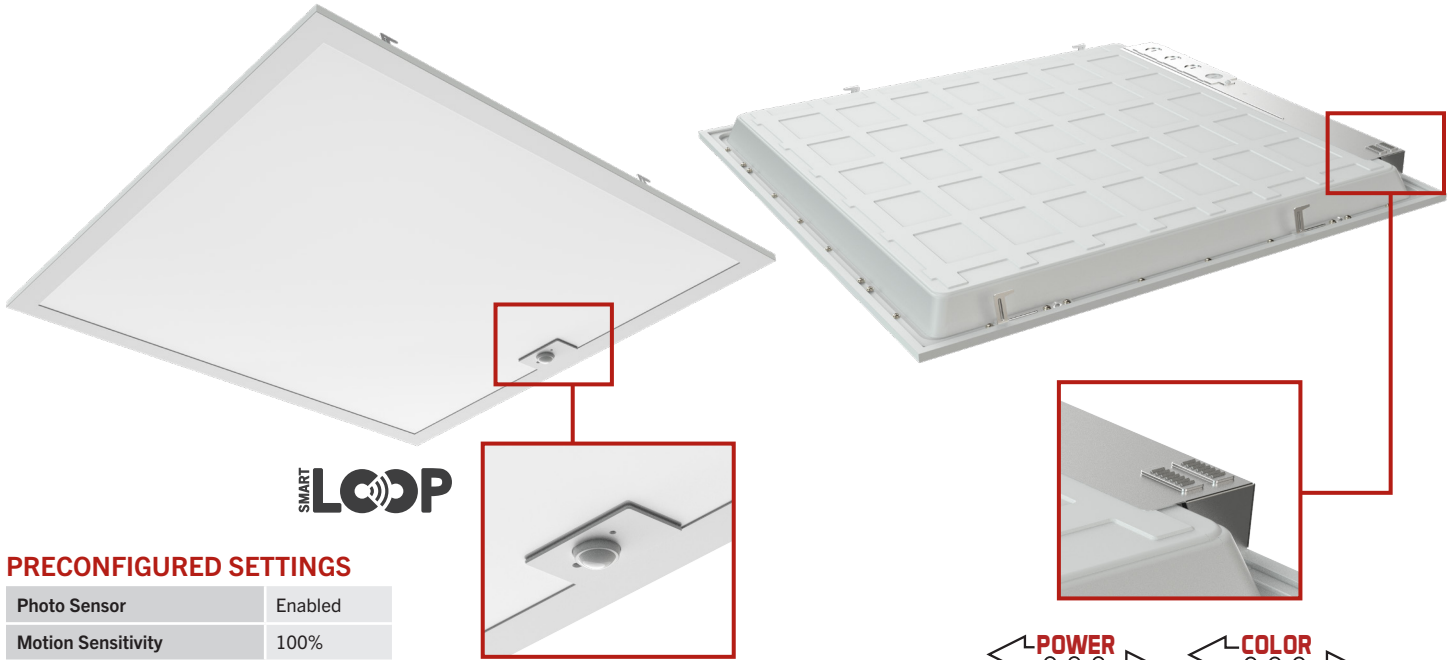

PRECONFIGURED SETTINGS

Photo Sensor	Enabled
Motion Sensitivity	100%
Motion Sensor	Enabled
Motion Mode	Occupancy
Hold Time	20m
Standby Time	1m
Standby Percentage	50%

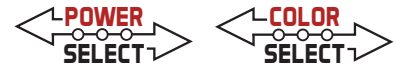

PHOTOMETRIC SPECIFICATIONS

ISOCANDELA PLOT

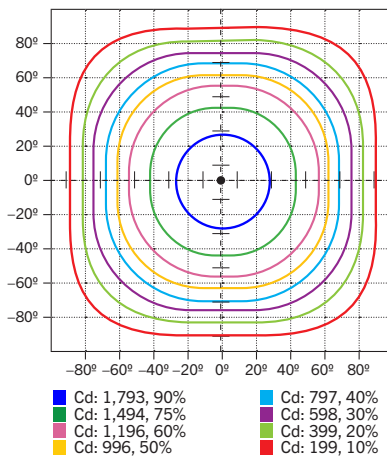

POLAR CANDELA DISTRIBUTION

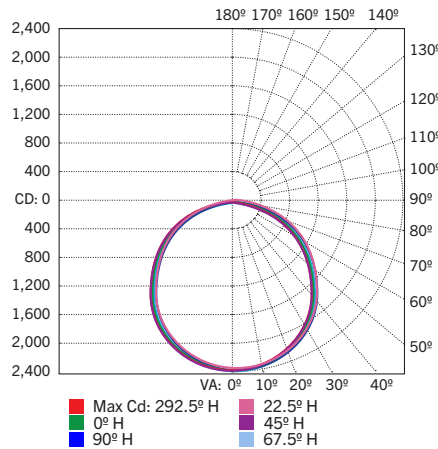

ZONAL LUMEN SUMMARY

Zone	Lumens	% Luminaire
0-60	3,252.2	78.4%
60-90	891.5	21.5%
0-90	4,147.6	100%

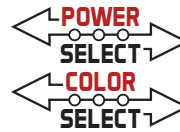

KT-BPLED40PS-22B-8CSA-VDIM /FC2

BACKLIT LED PANEL LIGHT

SENSOR PERFORMANCE

ELECTRICAL SPECIFICATIONS	
RF Transmit Power	8dBm
Wireless Frequency	2.4GHz
Wireless Range (Open Air)	100ft
Wireless Protocol	Bluetooth 4.2
Sensor Detection Height	16' max
Daylight Harvesting Range	100-1000 lux

SENSOR COVERAGE

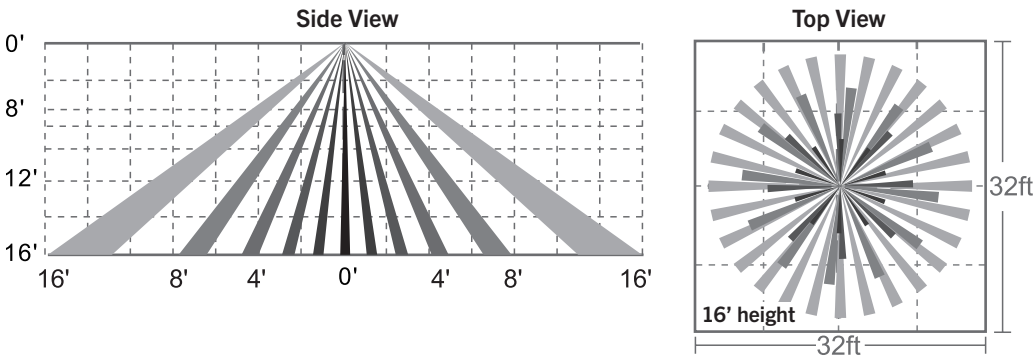

PHYSICAL SPECIFICATIONS

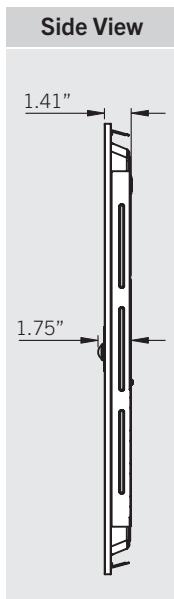
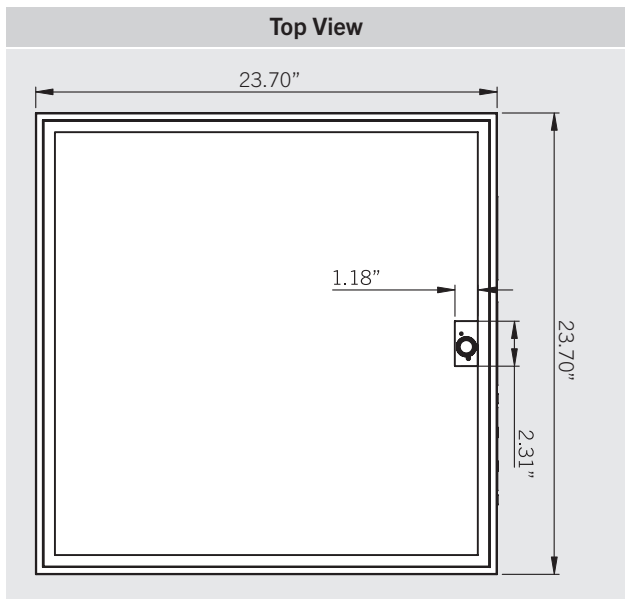

WEIGHT INFORMATION

1 Piece	1 Carton
6.2 lbs	12.4 lbs



KT-BPLED40PS-22B-8CSA-VDIM /FC2

BACKLIT LED PANEL LIGHT

ACCESSORIES

SENSORS

Field-Installable / Field-Use **ONLY** (purchased separately)

CATALOG NUMBER	DESCRIPTION	UPC	EASY CODE
KTSL-WS1-B-SG /G2	Bluetooth mesh wireless battery powered wall switch for SmartLoop system	843654141695	FYH-31



CORD SETS

Factory-Installable **OR** Field-Installable (field-installable purchased separately)

✓	SUFFIX*	CATALOG NUMBER	DESCRIPTION	UPC	EASY CODE
	/515P6	KT-CS-515P-6-18/3	Cord set for high bay; 125V NEMA 5-15P; straight blade plug; 6' SJTOW cable; 18/3 wire	843654140124	UKH-26
	/L715P10	KT-CS-L715P-10-16/3	Cord set for high bays; 277V NEMA L7-15P; twist lock plug; 10' SJTOW cable; 16/3 wire	843654140131	SFV-88
	/L615P10	KT-CS-L615P-10-16/3	Cord set for high bays; 250V NEMA L6-15P; twist lock plug; 10' SJTOW cable; 16/3 wire	843654140148	ZQS-05
	/L515P10	KT-CS-L515P-10-16/3	Cord set for high bays; 250V NEMA L5-15P; twist lock plug; 10' SJTOW cable; 16/3 wire	843654140155	GVH-22
	/L715P6	KT-CS-L715P-6-16/3	Cord set for high bays; 277V NEMA L7-15P; twist lock plug; 6' SJTOW cable; 16/3 wire	843654140162	DVU-44
	/L615P6	KT-CS-L615P-6-16/3	Cord set for high bays; 250V NEMA L6-15P; twist lock plug; 6' SJTOW cable; 16/3 wire	843654140179	LCW-66
	/L515P6	KT-CS-L515P-6-16/3	Cord set for high bays; 250V NEMA L5-15P; twist lock plug; 6' SJTOW cable; 16/3 wire	843654140186	POC-82
	/MC63	KT-MC-NP-6-18/3	MC cable whip for high bays; no plug; inners 1/2" strip on both ends; 6' metal-clad cable; 18/3 wire	843654134505	EYP-82
	/MC65	KT-MC-NP-6-18/5	MC cable whip for high bays; no plug; inners 1/2" strip on both ends; 6' metal-clad cable; 18/5 wire (dimming wires included)	843654134512	CBU-56
	/NP10	KT-CS-NP-10-16/3	Cord for high bays; no plug; inners 1/2" strip on both ends; 10' SJTOW cable; 16/3 wire	843654140193	YOH-90
	/NP6	KT-CS-NP-6-16/3	Cord for high bays; no plug; inners 1/2" strip on both ends; 6' SJTOW cable; 16/3 wire	843654140216	HUB-73
	/NP15	KT-CS-NP-15-16/3	Cord for high bays; no plug; inners 1/2" strip on both ends; 15' SJTOW cable; 16/3 wire	843654140209	EYD-18

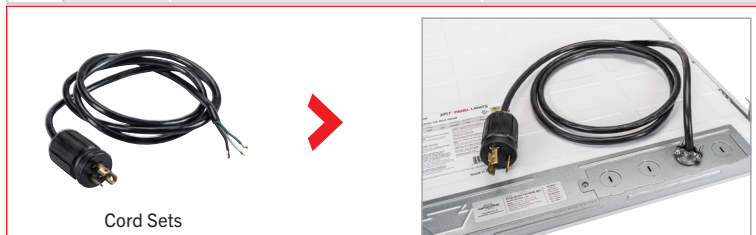

* For factory installation of accessory, add suffix to fixture part number (see ordering examples and instructions on last page of spec sheet).
Note: For cord sets not listed here, please contact your Keystone sales rep.

(Accessories continued on next page)

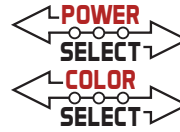

KT-BPLED40PS-22B-8CSA-VDIM /FC2

BACKLIT LED PANEL LIGHT

ACCESSORIES (continued)

EMERGENCY BACKUP

Factory-Installable **OR** Field-Installable (field-installable purchased separately)

✓	SUFFIX*	CATALOG NUMBER	DESCRIPTION	UPC	EASY CODE
	/EM5†	KT-EMRG-LED-5C-500-EN /DF	5W, 500 lumen Smart Safe emergency backup with dual flex cables	843654132433	RAR-74
	/EM12†	KT-EMRG-LED-12C-1200-EN /DF	12W, 1200 lumen Smart Safe emergency backup with dual flex cables	890949019900	YCV-23



* For factory installation of accessory, add suffix to fixture part number (see ordering examples and instructions on last page of spec sheet).
 † Factory installation of emergency backup units will automatically include any relevant mounting bracket.

Field-Installable / Field-Use **ONLY** (purchased separately)

CATALOG NUMBER	DESCRIPTION	UPC	EASY CODE
KT-BPLED-EM-22/4-KIT	Emergency LED Backup Mounting Kit for Keystone Backlit Panels	843654128047	EIG-03



(Accessories continued on next page)

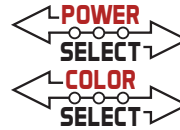

KT-BPLED40PS-22B-8CSA-VDIM /FC2

BACKLIT LED PANEL LIGHT

ACCESSORIES (continued)

MOUNTS AND BRACKETS

Factory-Installable OR Field-Installable (field-installable purchased separately)

✓	SUFFIX*	CATALOG NUMBER	DESCRIPTION	UPC	EASY CODE
	/JBOX	KT-BPLED-JBOX-1	Larger J-Box add-on for LED Backlit Panels	843654128092	MYW-25

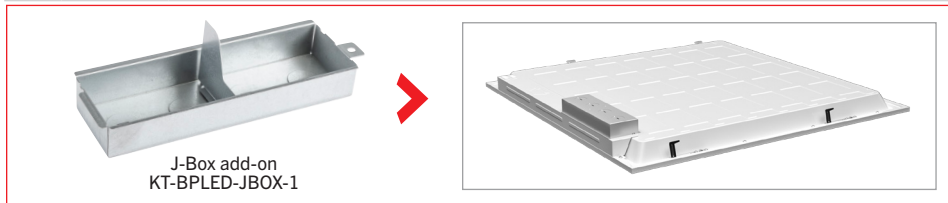

* For factory installation of accessory, add suffix to fixture part number (see ordering examples and instructions on last page of spec sheet).

Field-Installable / Field-Use ONLY (purchased separately)

CATALOG NUMBER	DESCRIPTION	UPC	EASY CODE
KT-BPLED-SM-22-KIT /G2	Surface Mount Kit 2x2 Backlit panels	843654134543	CGY-52
KT-BPLED-CABLE-KIT	Aircraft cable hanging kit for LED Backlit fixtures	843654133423	JLB-77

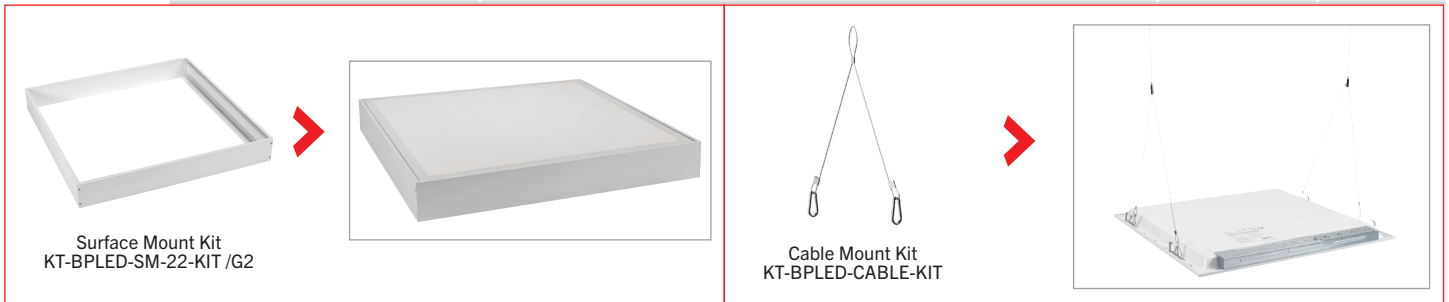

(Accessories continued on next page)



KT-BPLED40PS-22B-8CSA-VDIM /FC2

BACKLIT LED PANEL LIGHT

ORDERING INFORMATION

Order Code	Carton Quantity	UPC	Easy Code
KT-BPLED40PS-22B-8CSA-VDIM /FC2	2	843654151595	HQ0-03

CATALOG NUMBER BREAKDOWN

KT-BPLED40PS-22B-8CSA-VDIM /FC2

1	2	3	4	5	6	7	8	9	10	11	12	
1 Keystone Technologies	2 Backlit Panel Light LED Fixture	3 Wattage	4 Power Select	5 Nominal Size	6 Style/Design Designation	7 80 CRI	8 Color Select	9 Color Select Designation	10 0-10V Dimming	11 Built-In Smartloop KTSL-FC2-12V-SM-PIR Sensor	12 Color Select Designation	
											A	3500/4000/5000K

ORDERING EXAMPLES

FIXTURE WITH MULTIPLE FACTORY-INSTALLED ACCESSORIES*

KT-BPLED40PS-22B-8CSA-VDIM /FC2 /L715P6/EM5/JBOX

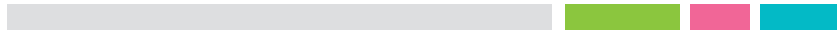

FIXTURE WITH MULTIPLE FACTORY-INSTALLED ACCESSORIES*

KT-BPLED40PS-22B-8CSA-VDIM /FC2 /EM5/JBOX

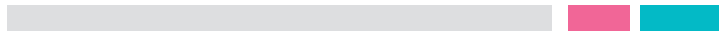

FIXTURE WITH TWO FACTORY-INSTALLED ACCESSORIES*

KT-BPLED40PS-22B-8CSA-VDIM /FC2 /L715P6

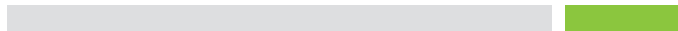

FIXTURE WITH NO FACTORY-INSTALLED ACCESSORIES

KT-BPLED40PS-22B-8CSA-VDIM /FC2

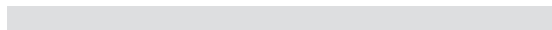

KEYSTONE FIXTURE	
CATALOG NUMBER	
	KT-BPLED40PS-22B-8CSA-VDIM /FC2

CORD SETS	
SUFFIX	CATALOG NUMBER
✓ /L715P6	KT-CS-L715P-6-16/3

EMERGENCY BACKUP	
SUFFIX	CATALOG NUMBER
✓ /EM5	KT-EMRG-LED-5C-500-EN /DF

MOUNTS AND BRACKETS	
SUFFIX	CATALOG NUMBER
✓ /JBOX	KT-BPLED-JBOX-1

* When ordering more than one factory-installed accessory, use multiple suffixes as shown in the ordering examples above.
 Note: All accessories can also be ordered separately for field installation using just their regular Catalog Number, UPC, or Easy Code.