

WHL-INDWLEZU NEMA4X/NSF Exit Sign

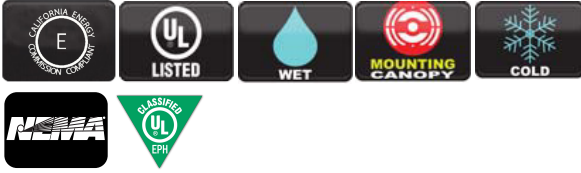

WAREHOUSE-LIGHTING.COM

STANDARD



OPTIONAL



ILLUMINATION

- Ultra bright, energy efficient, long life Red or Green LEDs.

ELECTRICAL

- Dual 120/277 voltage.
- Unique bi-color LED indicator light alerts occupant on battery condition (Green-normal, Red-check-battery).
- Charge rate/power "ON" LED indicator light and magnetic test switch for mandated code compliance testing.
- 4.8V long-life, maintenance-free, rechargeable NiCd battery (EM models only).
- Internal solid-state transfer switch automatically connects the internal battery to LED board for minimum 90-minute emergency illumination.
- Fully automatic solid-state, two-rate charger initiates battery charging to recharge a discharged battery in 24 hours.

MOUNTING

- Universal knockout pattern on back provided with gasket for watertight seal for back mount.
- Polycarbonate mounting canopy included for top or end mount

HOUSING

- Housing is reinforced polycarbonate construction in white or black finish.
- Corrosion-resistant enclosure with one piece, high-impact resistant, UV stabilized polycarbonate lens and molded gasket with stainless steel screws.
- Knockouts provided for conduit feed applications.
- EZ snap-out Chevron directional indicators.

OPTIONS

- SDT: Self-diagnostic feature performs monthly, biannual, and annual tests to ensure reliable operation and meet electrical and life safety codes.
- 2C-120V/2C-277V: Voltage-specific dual circuit option on the AC-only unit enables it to be connected to two different supplies at the same time.
- TP: Tamper-proof hardware helps discourage unauthorized access to the unit.

WARRANTY / LISTING

- Five year warranty on all electronics and housing. Batteries prorated for five years.
- Meets UL924, NFPA101 Life Safety Code, NEC, OSHA, Local and State Codes.
- IP66 rated for Ingress protection.
- NEMA4X and NSF rated.
- Certified to CEC under Title 20 Regulations.
- UL certified for use in food service operations.
- UL listed for wet locations (-20°C – 50°C).

DIMENSIONS

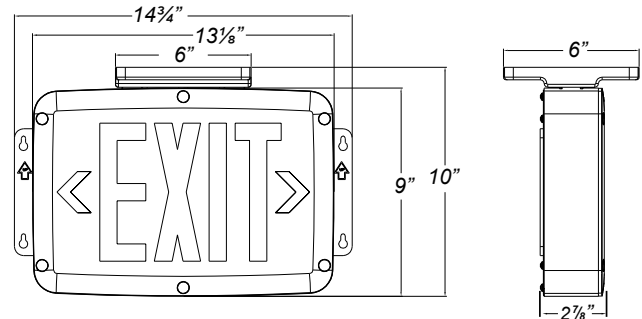

ORDERING INFORMATION

Sample Part Number: WHL-INDWLEZU1RBEMSDT

MODEL	No. of FACES	LETTER COLOR	HOUSING COLOR	BATTERY	OPTIONS
WHL-INDWLEZU	1	Single	R Red	W White	(blank)
	2	Double	G Green	B Black	EM NiCd Battery
					SDT Self-Diagnostics ¹
					2C-120 Dual Circuit With 120V Input ²
					2C-277 Dual Circuit With 277V Input ²
					TP Tamper-Proof

¹ Available in EM units only.

² Not available with EM units.



WAREHOUSE-LIGHTING.COM

Warehouse-Lighting.com
2750 South 163rd St
New Berlin, WI 53151

Warehouse-Lighting.com
Phone: 888-454-4480
requests@warehouse-lighting.com