

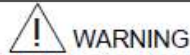

WAREHOUSE-LIGHTING.COM  
INDUSTRIAL AND COMMERCIAL  
LIGHTING MFR SINCE 2003

# Beam G2 Installation Guide

Read Instruction manual carefully to ensure proper installation.  
Please keep this instruction manual for future using!



## WARNING

To avoid the risk of fire, or electric shock this product should be installed, inspected, and maintained by a qualified electrician only. Installation should be completely by an individual familiar with the construction and operation of the luminaire. Installation of luminaire must be in accordance with nation and local building and electrical codes.

### Safety Warning:

To avoid electric shock:

Be certain electrical power is OFF before and during installation and maintenance.  
Luminaire must be supplied by a wiring system with an equipment grounding conductor.

To avoid burning hands:

Make sure lens and housing are cool when performing maintenance.

To avoid product degradation:

Make sure the wire supply voltage is the same as the luminaire supply

Use proper supply wiring as specified on the luminaire nameplate.

Avoid use in environments containing sulfur, chlorine, or other halides, methyl acetate or ethyl acetate, cyanoacrylates, glycol ethers, formaldehyde or butadiene.

### Notes:

Instructions do not cover all details and all possible product configurations.

Do not restrict luminaire ventilation.

Ensure LED luminaire is not covered with material that will prevent convection or conduction cooling.

Ensure LED luminaire has the correct polarity before installation

Avoid exposing wiring to metal edges and sharp objects.

### Maintenance:

Perform visual, electrical, and mechanical inspections on a regular basis. The environment and frequency of use should determine this. However, it is recommended that checks be made at least once a year. Electrically check to make sure that all connections are clean and tight. Mechanically check that all parts are properly assembled.



WAREHOUSE-LIGHTING.COM  
 INDUSTRIAL AND COMMERCIAL  
 LIGHTING MFR SINCE 2003

# Beam G2 Installation Guide

## Installation Dimension(suspended)

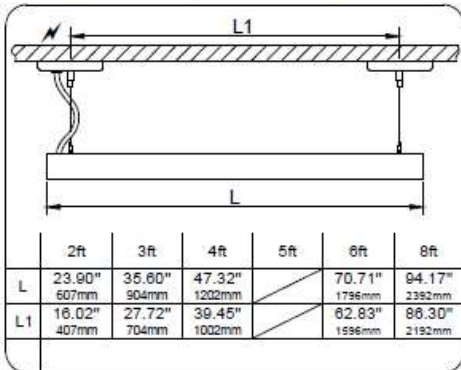

## Surface mounted

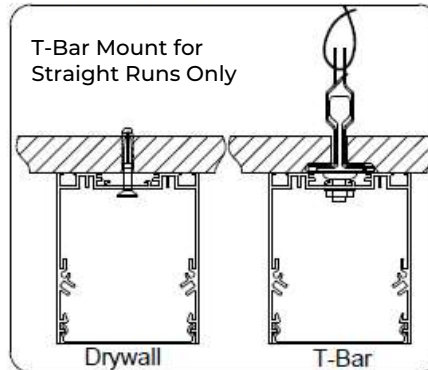

## Dip switch for CCT

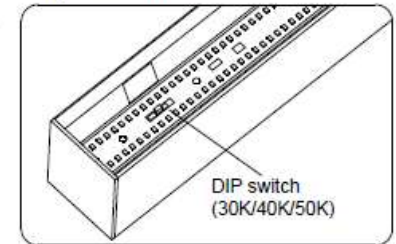

## Wiring Diagram

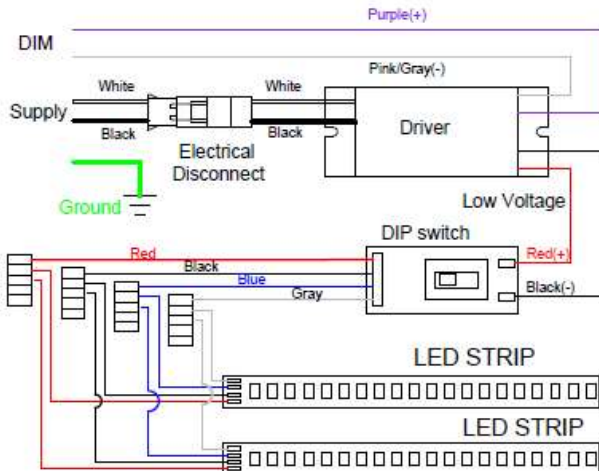

## SUSPENDED MOUNT

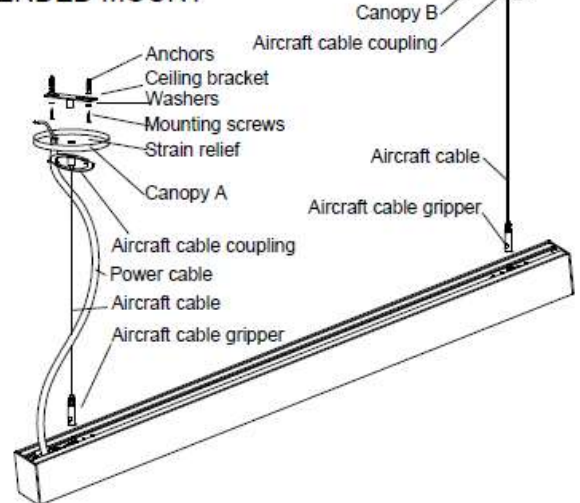





WAREHOUSE-LIGHTING.COM

INDUSTRIAL AND COMMERCIAL  
LIGHTING MFR SINCE 2003

# Beam G2 Installation Guide

## ■ SUSPENDED MOUNT(C) (UP & DOWN LIGHTING VERSION)

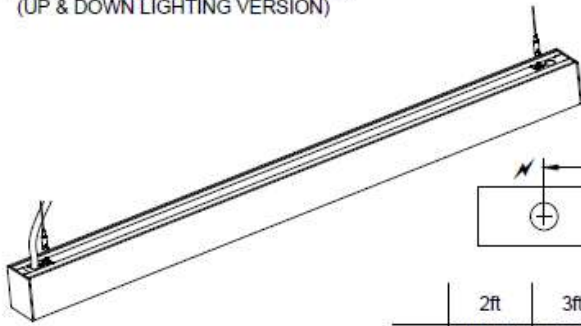

	2ft	3ft	4ft	5ft	6ft	8ft
A	18.98" 482mm	30.67" 779mm	42.40" 1077mm		65.79" 1671mm	89.17" 2265mm

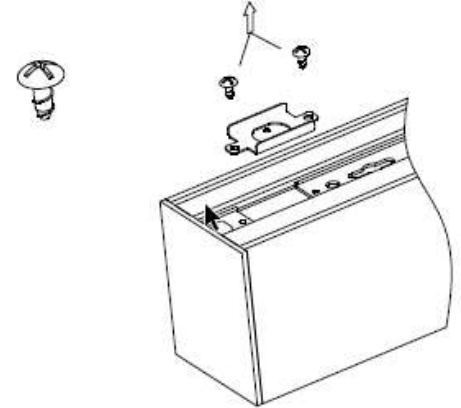

C-A) (A)

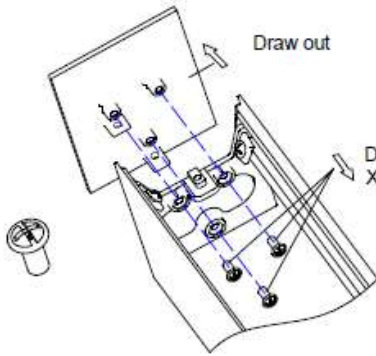

C-B)

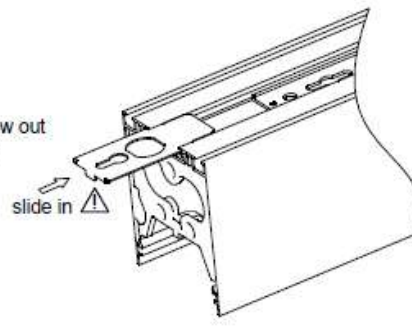

C-C)

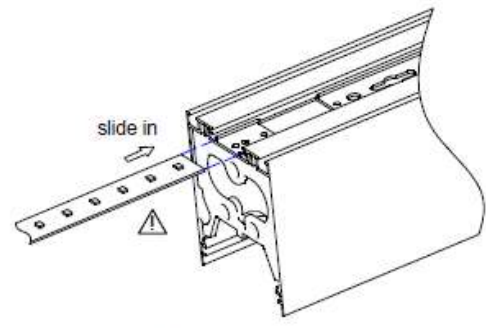

C-D)



WAREHOUSE-LIGHTING.COM

INDUSTRIAL AND COMMERCIAL  
LIGHTING MFR SINCE 2003

# Beam G2 Installation Guide

## ■ SUSPENDED MOUNT(C) (UP & DOWN LIGHTING VERSION)

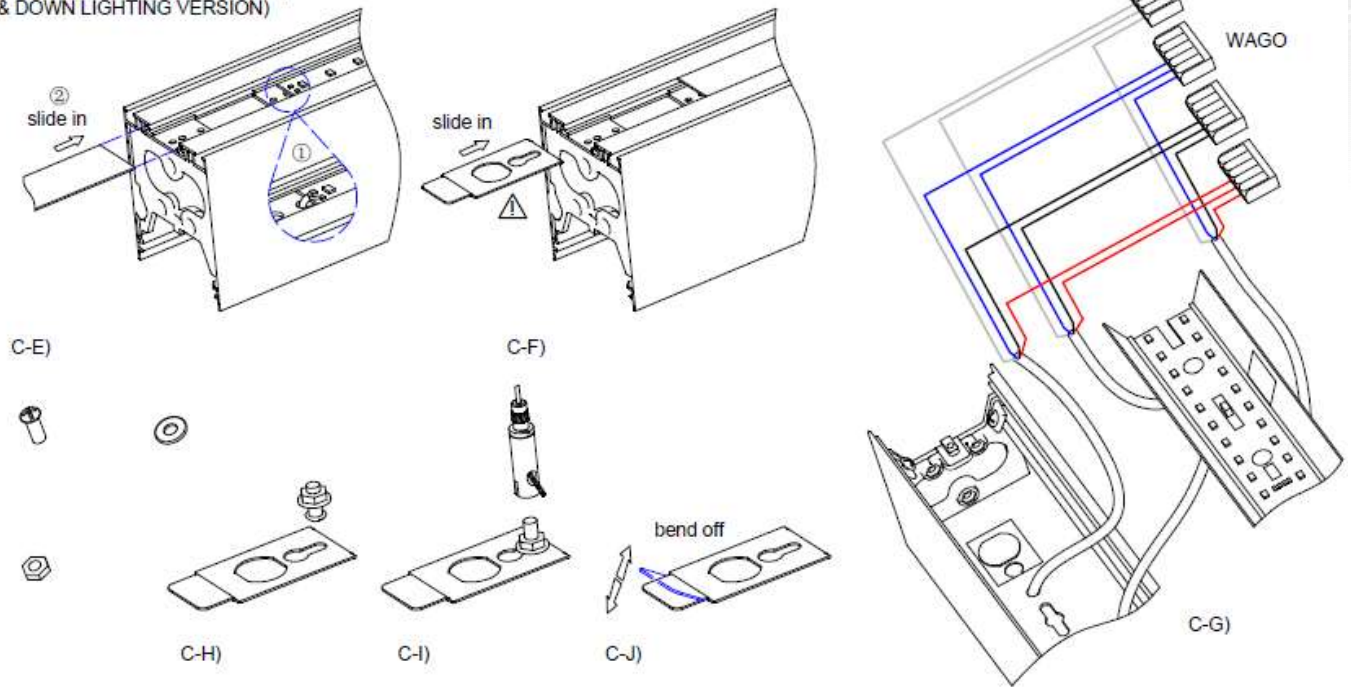



WAREHOUSE-LIGHTING.COM

INDUSTRIAL AND COMMERCIAL  
LIGHTING MFR SINCE 2003

# Beam G2 Installation Guide

## CONNECTION(D) WITH CORNERS

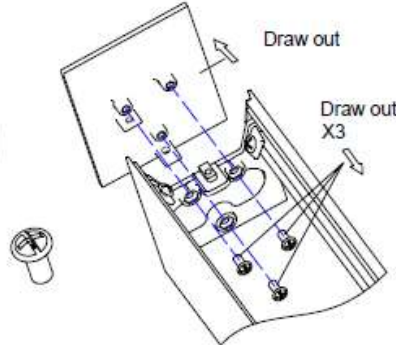
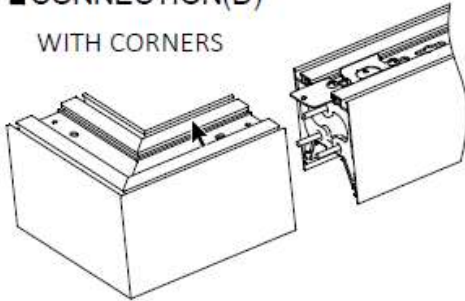

D-A)

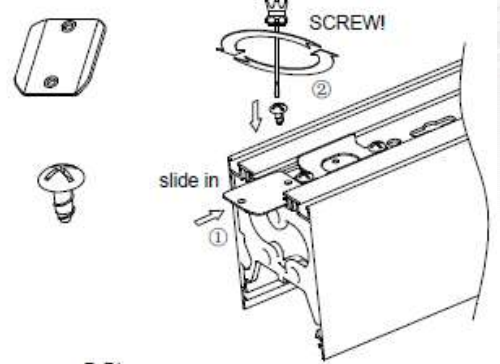

D-B)

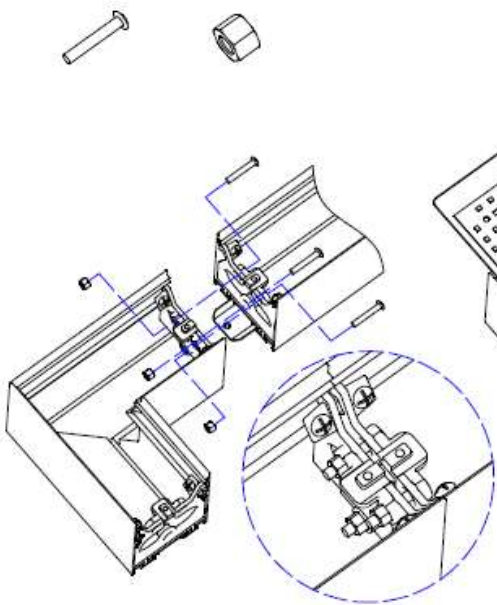

D-C)

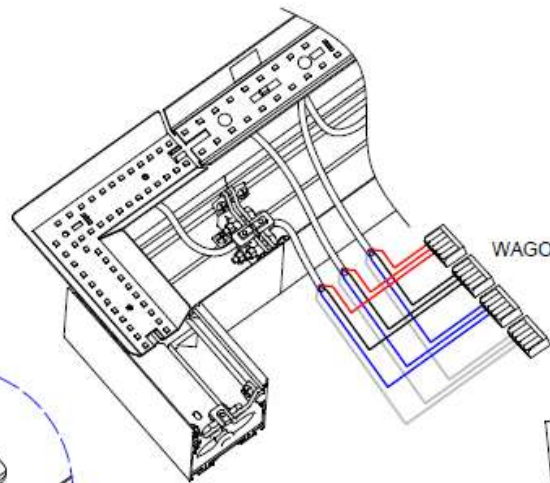

D-D)

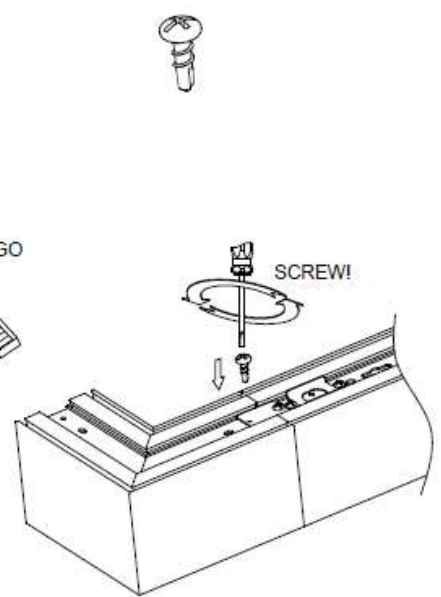

D-E)



WAREHOUSE-LIGHTING.COM

INDUSTRIAL AND COMMERCIAL  
LIGHTING MFR SINCE 2003

# Beam G2 Installation Guide

■ (E)

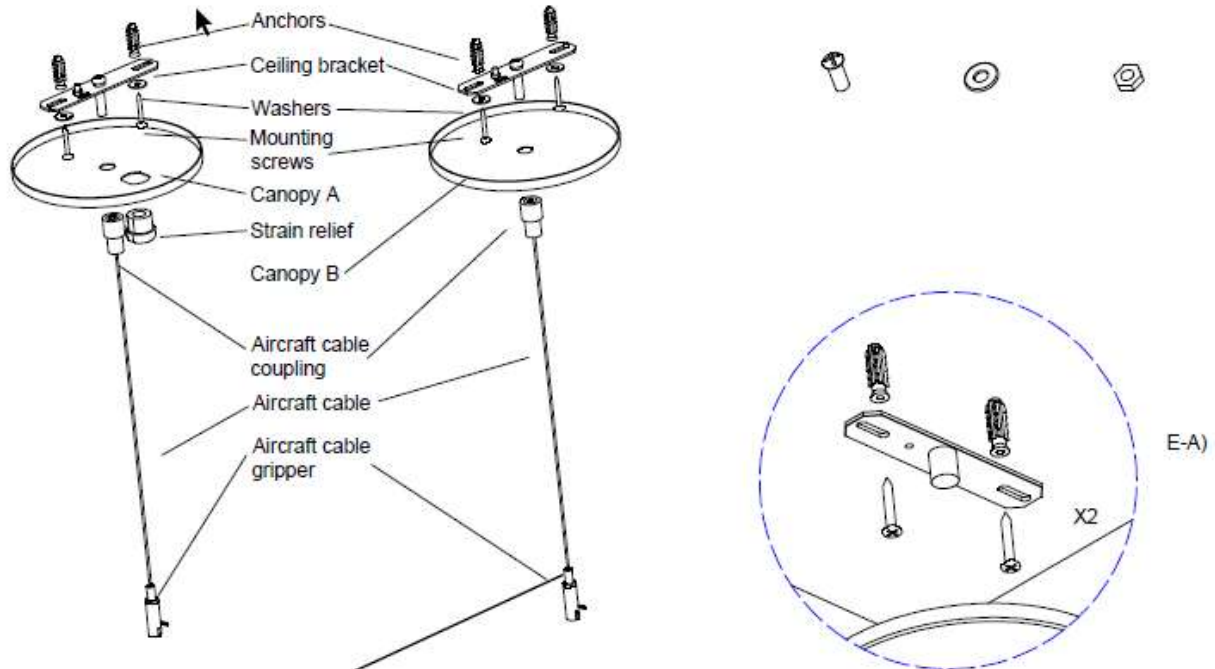

LOOSE THIS ACCESSORY AND THEN PULL THE AIRCRAFT CABLE TO ADJUST THE LENGTH

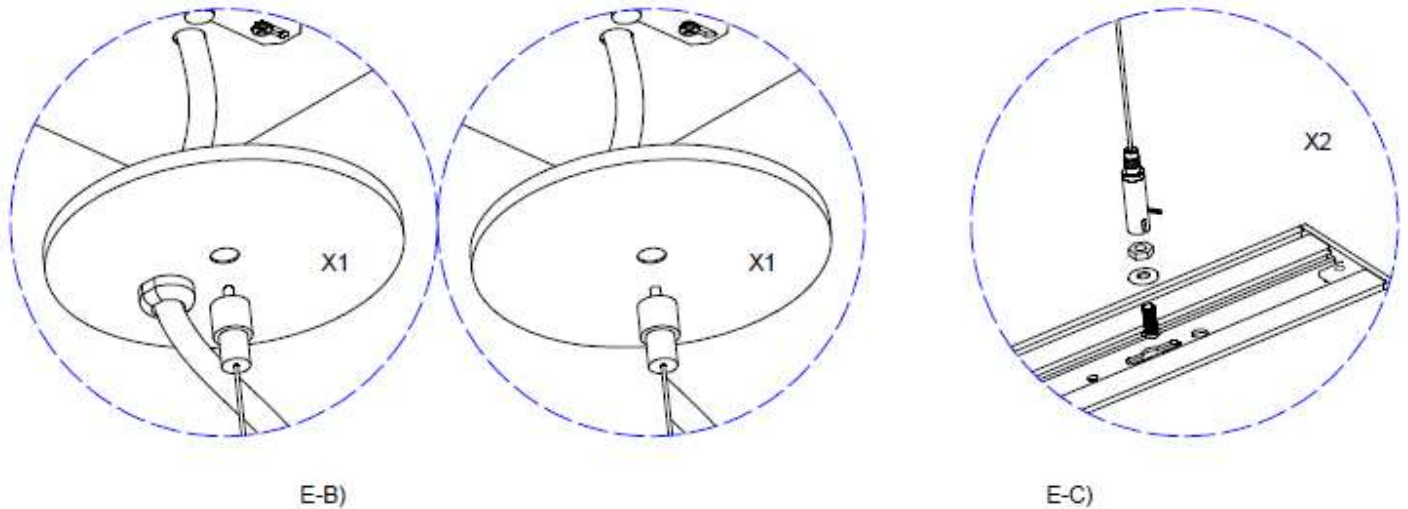



WAREHOUSE-LIGHTING.COM

INDUSTRIAL AND COMMERCIAL  
LIGHTING MFR SINCE 2003

# Beam G2 Installation Guide

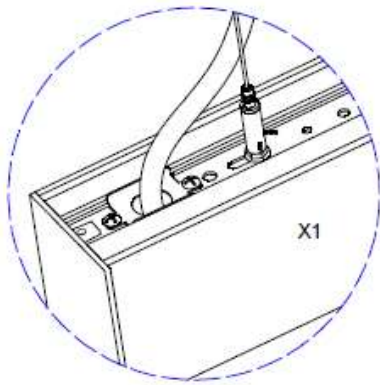

E-D)

THIS BRACKET IS NOT EASY TO TAKE OUT FOR SAFETY,BUT IT CAN SLIDE

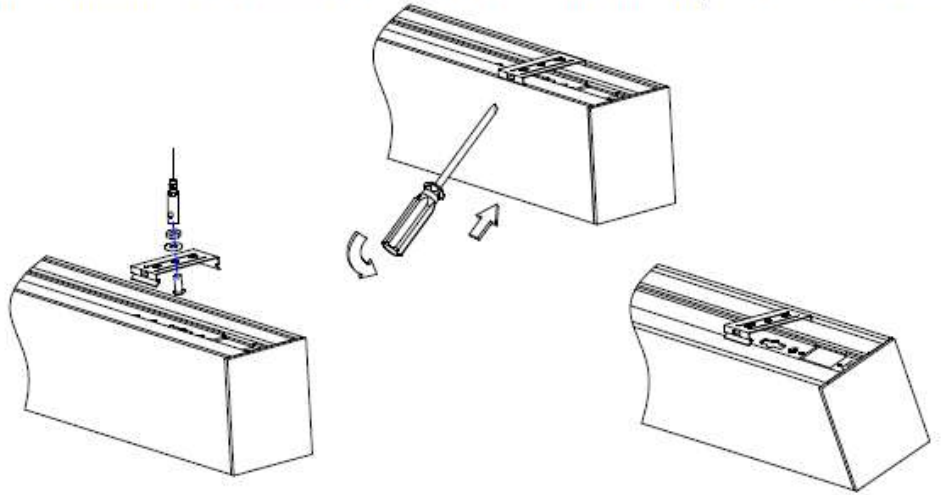





WAREHOUSE-LIGHTING.COM

INDUSTRIAL AND COMMERCIAL  
LIGHTING MFR SINCE 2003

# Beam G2 Installation Guide

## ■ ELECTRICAL CONNECTION(H)

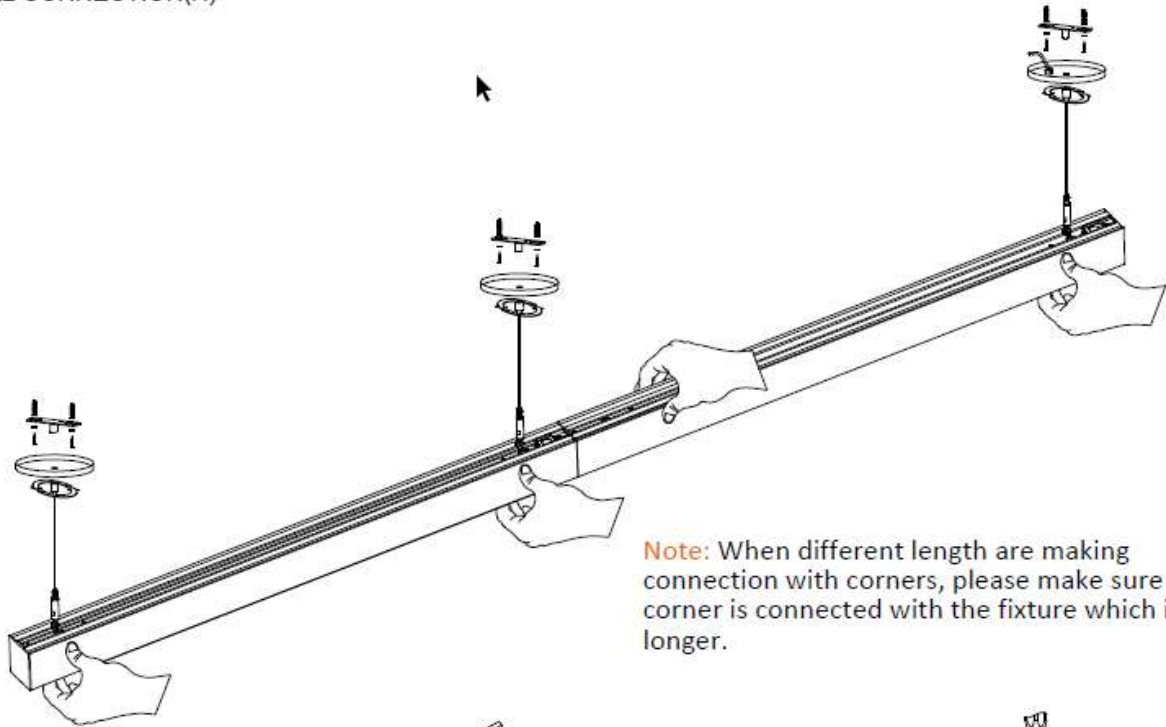

**Note:** When different length are making connection with corners, please make sure the corner is connected with the fixture which is longer.

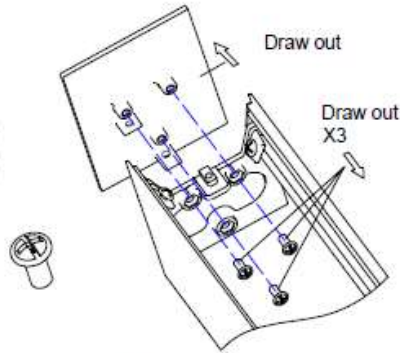
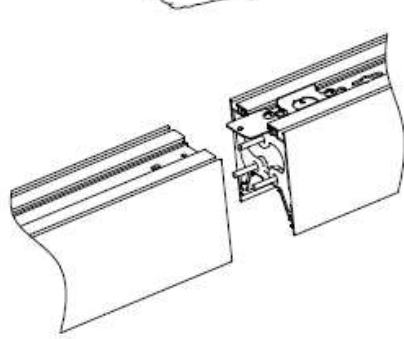

H-A)

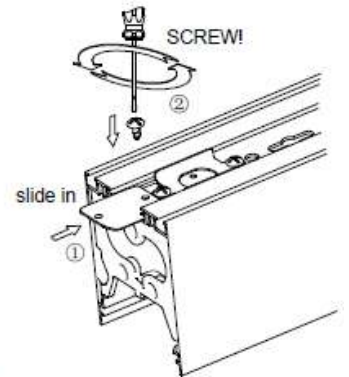
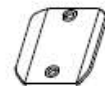

H-B)





WAREHOUSE-LIGHTING.COM

INDUSTRIAL AND COMMERCIAL  
LIGHTING MFR SINCE 2003

# Beam G2 Installation Guide

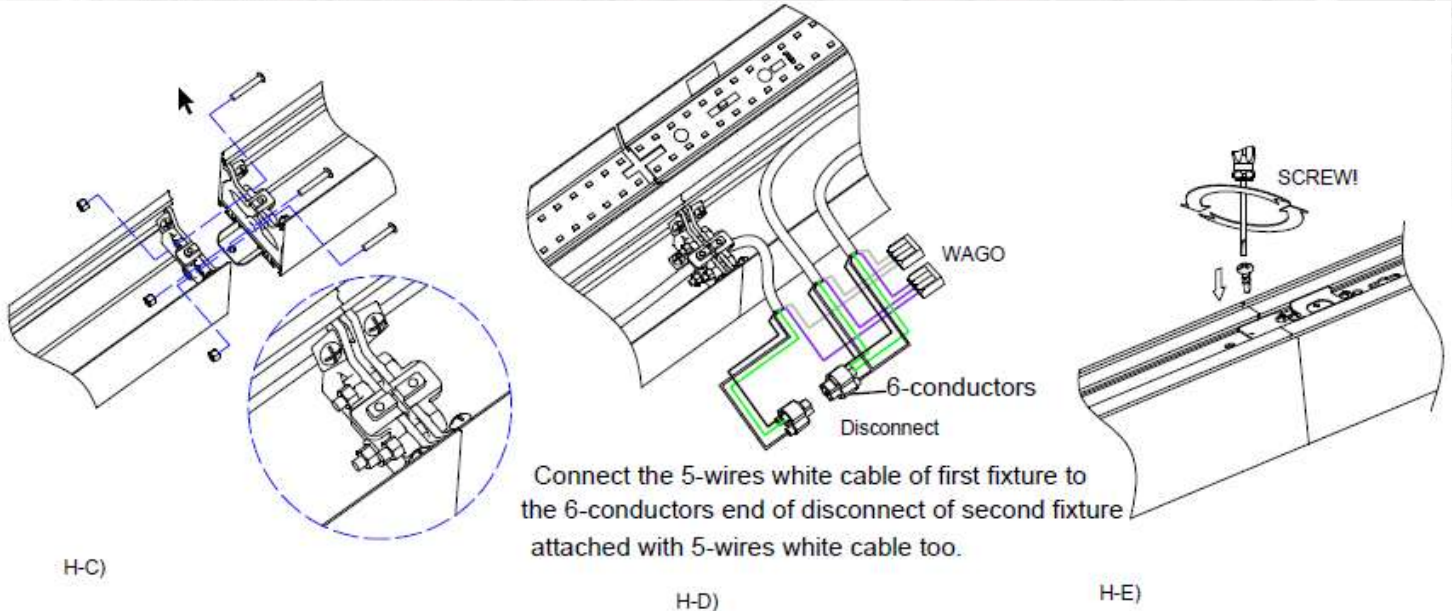



WAREHOUSE-LIGHTING.COM

INDUSTRIAL AND COMMERCIAL  
LIGHTING MFR SINCE 2003

# Beam G2 Installation Guide

## ■ (F) Aluminum Flanges installation

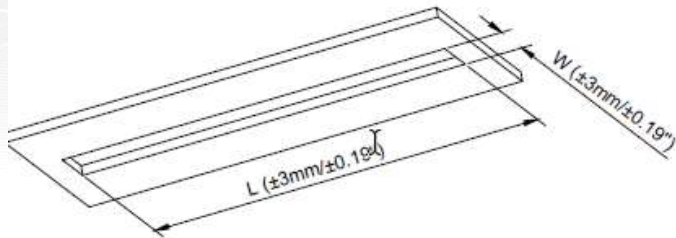

	2ft	3ft	4ft	5ft	6ft	8ft
L	24.45" 621mm	36.14" 918mm	47.87" 1218mm		71.30" 1811mm	94.69" 2405mm
W			3.27" 83mm			

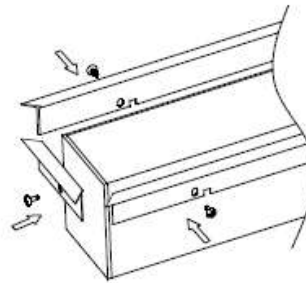

F-A)

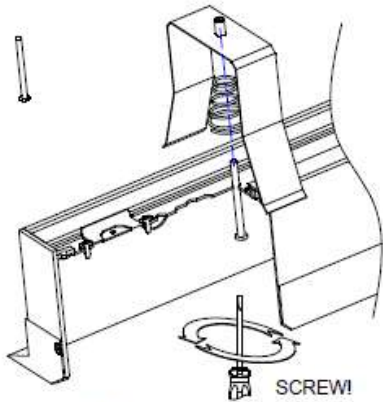
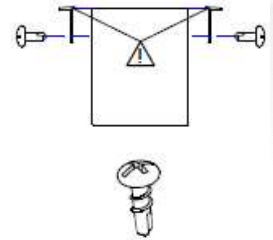

F-B)

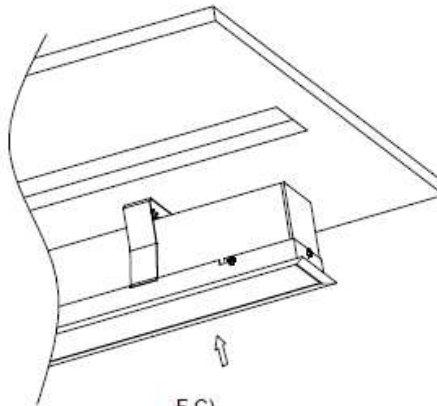

F-C)

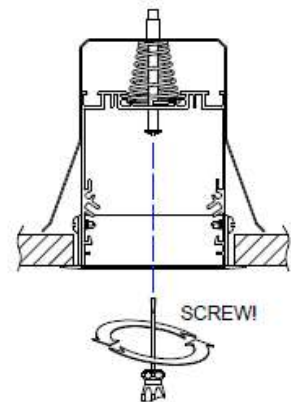



WAREHOUSE-LIGHTING.COM

INDUSTRIAL AND COMMERCIAL  
LIGHTING MFR SINCE 2003

# Beam G2 Installation Guide

## ■ (G) MUD-IN FLANGE INSTALLATION

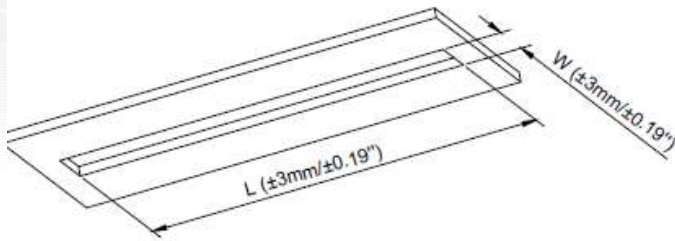

	2ft	3ft	4ft	5ft	6ft	8ft
L	24.45" 621mm	36.14" 918mm	47.87" 1216mm	59.60" 1514mm	71.30" 1811mm	94.69" 2405mm
W	3.27" 83mm					

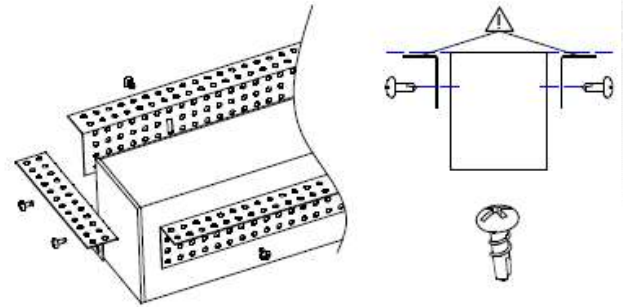

G-A)

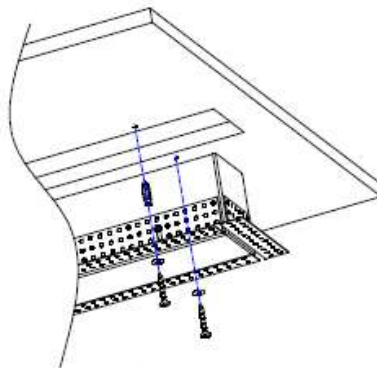

G-B)

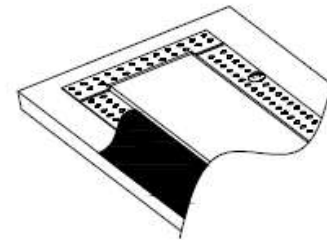

G-C)



WAREHOUSE-LIGHTING.COM

INDUSTRIAL AND COMMERCIAL  
LIGHTING MFR SINCE 2003

# Beam G2 Installation Guide

## ■ Wall Mounted

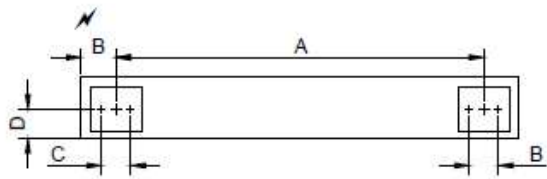
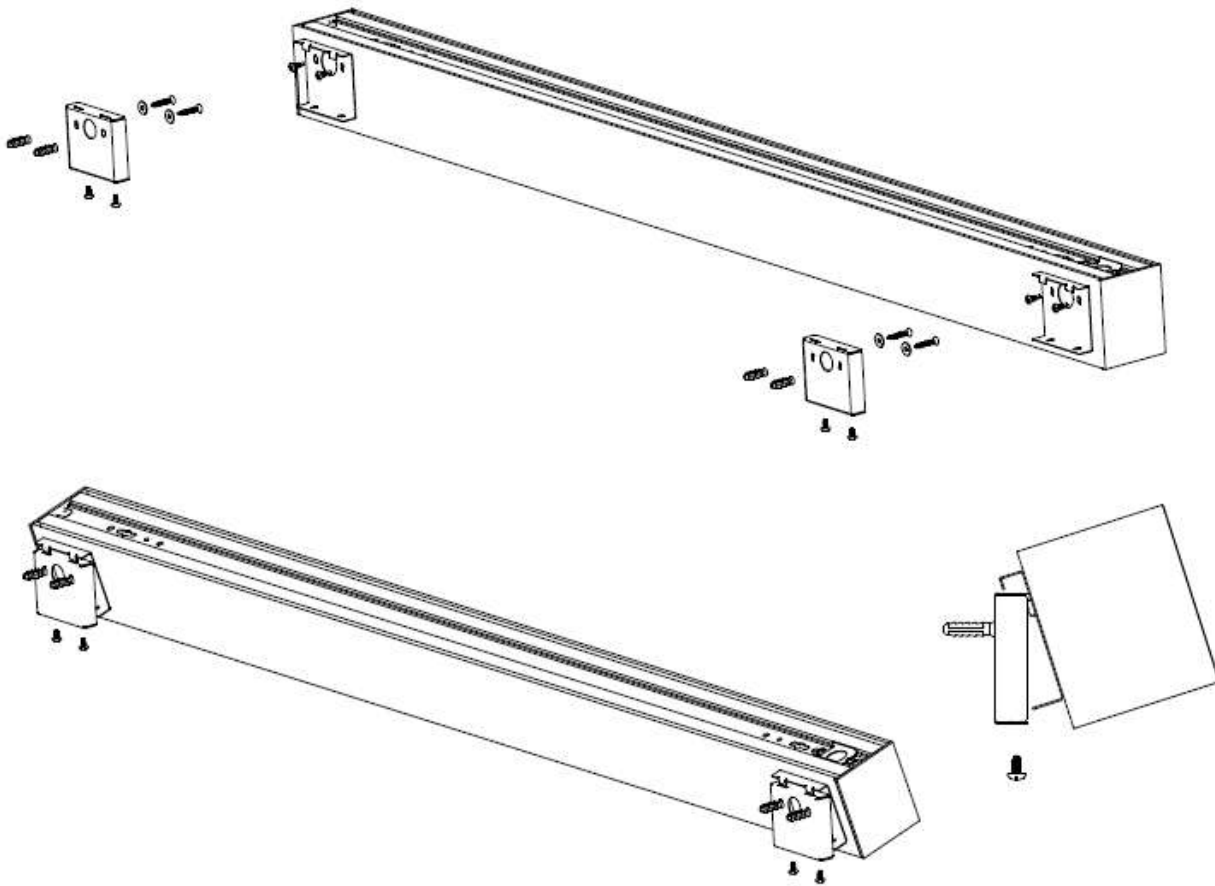

	2ft	3ft	4ft	6ft	8ft
A	19.88" 505mm	31.57" 802mm	43.31" 1100mm	66.69" 1694mm	90.16" 2290mm
B	2" 50.8mm				
C	1.57" 40mm				
D	1.57" 40mm				



WAREHOUSE-LIGHTING.COM  
INDUSTRIAL AND COMMERCIAL  
LIGHTING MFR SINCE 2003

# Beam G2 Installation Guide

## Instructions for Linking Fixtures

1. To access the inside of the fixture, carefully remove the lens from the fixture with the tool included in the small hardware bag.
2. Once you have removed the lens, remove the Phillips head screws on each end of the internal reflector and panel containing the led strip. Gently remove the reflector and led panel (do not touch the leds) and place to the side.
3. The fixture endplates will need to be removed to link the fixtures together. For the first fixture in the run will use the supplied power feed cable wire to the main supply voltage in your building. On the other side of the fixture (opposite the power feed cable) remove the end plate.
4. For the second fixture in the run, remove the end plate nearest to the attached power feed cable.
5. Place the fixtures with the top side of the fixture facing upward.
6. Slide the small, galvanized linking bracket into the upper channel on the topside of the fixture. Align the hole in the bracket with the hole in the fixture and secure the bracket to the first fixture using the included screw.
7. Slide the galvanized bracket into the upper channel of the 2<sup>nd</sup> fixture and secure with included screw.
8. Flip the fixtures over with the inside of the fixture facing upward.
9. Bolt the two fixture together internally using the included connecting hardware.
10. Cut the packaging zip ties from the power feed cable for the 2<sup>nd</sup> fixture and pull the power feed cable through the top of the fixture through the knockout and into the fixture housing channel.
11. Run the cable from the 2<sup>nd</sup> fixture inside the fixture channel housing, through the opening created by removing the fixture endplate, into the 1<sup>st</sup> fixture. Connect the stripped ends of the black, white and green leads from the 2<sup>nd</sup> fixture power feed cable to the orange driver disconnect of fixture 1 by pushing the wire into the open ports of the orange driver connector, aligning the corresponding colors.
12. The remaining two dimming leads (pink, purple) can now be connected to the first fixture. To do this, you will connect the individual wires together from each fixture utilizing the flat clear WAGO connector with orange levers. Lift a lever from the flat 5-conductor connector corresponding to an open port and insert the matching color wire. Press the lever down to secure the wire in the connector. Repeat procedure for the remaining dimming lead, making sure to connect to matching color.
13. For runs joining more than 2 fixtures together, repeat steps.