



Item#: **WL55765**
LED 8' SPEC-SELECT™
DESIGNER STRIP

DIRECT LINEAR AMBIENT LUMINARIES

FEATURES

Spec-Select™ Designer Strips are like 9 fixtures in 1, featuring adjustable wattage and color temperature for the perfect balance of light in any application.

- Adjustable Wattage (3 settings)
- Adjustable Color (3 settings)
- Integrated Sensor Option (ISO). Sensor and elbow sold separately.
- Easy installation.

APPLICATION

Ideal for larger warehouses, retail applications, commercial buildings and work areas.

ELECTRICAL

Wattage	65W / 75W / 90W
Voltage	120-277V
Current	90W @ 120V = 0.75A
Power Factor	0.9
Total Harmonic Distortion (THD)	5

LIGHTING PERFORMANCE

Lumens	8645 / 9975 / 11970
Lumens Per Watt (LPW)	133
Color Temperature (CCT)	3500K / 4100K / 5000K
Color Rendering (CRI)	82
R9 (Red Value)	6
Beam Angle	130°
Light Distribution	--
BUG Rating (Backlight, Uplight, and Glare)	--
Dimmable Lighting Control	From optional 12VDC sensor, or customer 0-10V controls.

ENVIRONMENT

Operating Temperature	-4 ~ 122°F
Suitable Location	DAMP
Ingress Protection Rating	IP40

LIFESPAN

Average Life (Hours)	50,000
Warranty (Years)	5

COMPONENTS

LED Light Source	Bridgelux
Driver	SIL80-I2000-SS
Sensor Socket	12VDC AUX.

CONSTRUCTION

Housing	Aluminum
Lens	Frosted
Base / Power Supply	Hard Wired
Finish	White

QUALIFICATIONS



Visit www.designlights.org/search to confirm qualification. • Published lumens on LED products are approximate and may vary slightly. • Specifications are subject to change without notice.

Item#: **WL55765**
LED 8' SPEC-SELECT™ DESIGNER STRIP



ITEM INFORMATION

DIMENSIONS (Inches)

Length	94.2"
Width	1.9"
Height	2.5"
Net Weight (Lbs)	--

SUPPORTING DOCUMENTS (Grey = not available at this time.)

Product Sheet	VIEW
Install Instructions	VIEW
IES Download from Web Item	VIEW
LM79	VIEW
LM80	VIEW

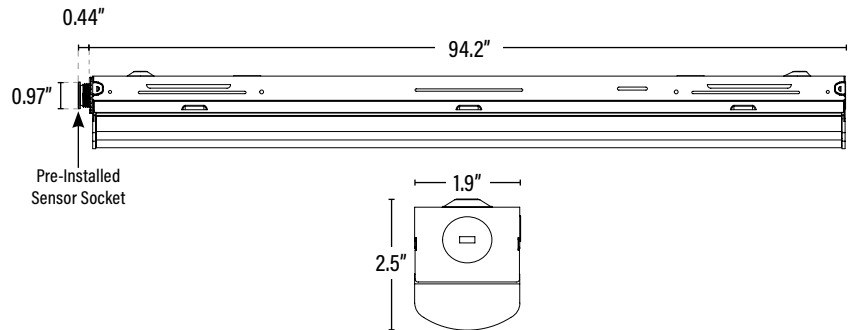

PACKAGING

		UPC	DIMENSIONS (LxWxH)	GROSS WEIGHT (Lbs)
Master Carton	4	10854432004450	96.6" x 5" x 5.8"	--
Individual Box	1	854432004453	95.5" x 2.2" x 2.7"	--
Country of Origin	China			
HS Tariff	--			

ORDERING

ITEM#	DESCRIPTION	CASE
55765	LED 8FT SPEC-SELECT™ DESIGNER STRIP/65-75-90W/35-50K/DIMM/ISO/120-277V - DLC®	4

ACCESSORIES

54871	BI-LEVEL PIR MOTION & DAYLIGHT SCREW-IN SENSOR FOR ISO STRIPS & VAPOR TIGHTS/40FT (REQUIRES 12-24VDC AUX & ELBOW #54876)	100
54872	BI-LEVEL MICROWAVE MOTION & DAYLIGHT SCREW-IN SENSOR FOR ISO STRIPS & VAPOR TIGHTS/40FT (REQUIRES 12-24VDC AUX & ELBOW #54876)	100
54876	EXTERNAL SWIVEL QUICK CONNECT ADJUSTABLE ELBOW FOR 54871/54872 (For best sensor performance.)	100
55454	ROW ALIGNER FOR DESIGNER STRIP	100

REPLACEMENT PARTS

54875	REPLACEMENT QUICK CONNECT SOCKET BASE FOR ISO	1
OBC-DS	OUTLET BOX COVER FOR DESIGNER STRIP	1
SIL80-I2000-SS	REPLACEMENT DRIVER	1

ADDITIONAL INFORMATION:

- Default settings; 65W, 5000K.
- The color temperature and wattage may be adjusted by two slide switches integrated into the driver. For additional information refer to the install instructions.

