

# Installation Instructions

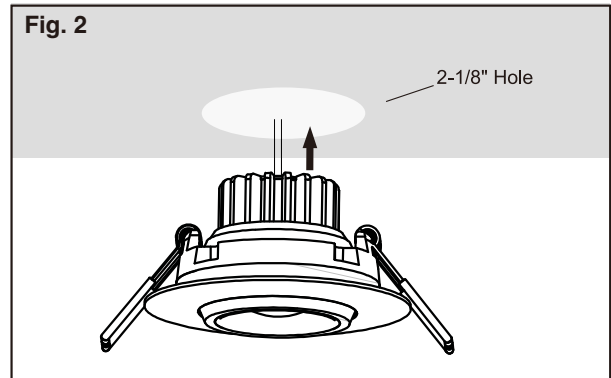
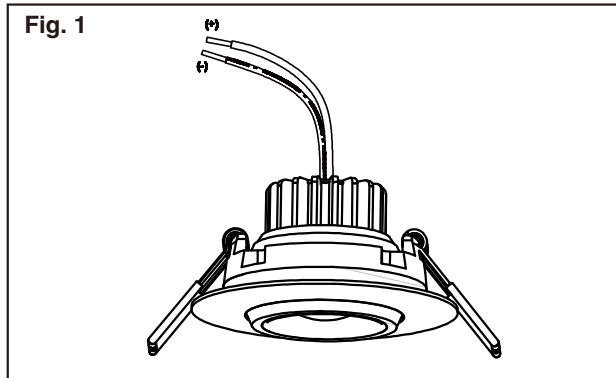

**IMPORTANT:** Read all instructions before installing fixtures. Retain for future reference.

- To be used only with listed class 2 power supplies.
- Always consider voltage drop effect when linking fixtures together.
- To extend driver life span, do not exceed 80% of driver rated load.

**SAFETY:** For your safety, this fixture must be wired in accordance to local electrical codes and ordinances. All work should be done by a qualified electrician.

**WARNING:** Make certain power is OFF from the electrical panel before starting installation or attempting any maintenance. Indoor installation only.

**1-PACK INCLUDED COMPONENTS**

- 1 X LED Snaptrim Adjustable Downlight

**TOOLS REQUIRED:**

- Power drill
- Screwdriver
- 2-1/8" cut hole size

**ASSEMBLY INSTRUCTIONS:**

- Open packaging and place all components onto a clean surface.
- Turn power OFF from the electrical panel before starting installation.

**RECESSED MOUNTING:**

With a screwdriver (supplied by others) detach the torsion clips from the LED puck light. In your desired area drill a 2 1/8" hole, using a cut hole saw (supplied by others). Run the wires through the cut hole, then secure the LED puck light to medium with screws provided (Fig 2). Connect the trim ring back to the LED light magnetic tag.

**HARDWIRE:**

- Use wire type and gauge suitable for application to connect the fixtures and twist-on wire connectors (supplied by others) (Fig. 3) Ensure correct polarity is followed through the line (Fig. 1)
- Rest the driver to the desired secured location
  - Once assembly is complete, turn on the power to confirm fixture is working properly.

