

- NOTES:
- (1) INSTALL 30 AMP CIRCUIT BREAKER ON SHIPS POSITIVE SUPPLY LEAD
  - (2) EACH REEL / RELAY BOX REQUIRES A SEPARATE SLAVE BATTERY IN A MULTI-REEL INSTALLATION
  - (3) SLAVE BATTERY MUST NOT BE GROUNDED TO VESSEL SYSTEM
  - (4) DO NOT CONNECT ANY OTHER DEVICES TO SLAVE BATTERY

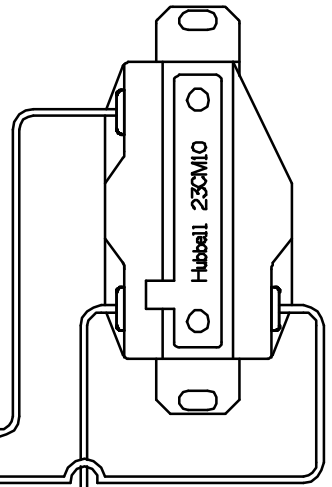

LINDGREN-PITMAN, INC.  
 12V TO 24V SLAVE BATTERY  
 RELAY BOX WIRING

PENN INTERNATIONAL  
 SHIMANO TIAGRA  
 ELECTRIC REEL CONVERSION

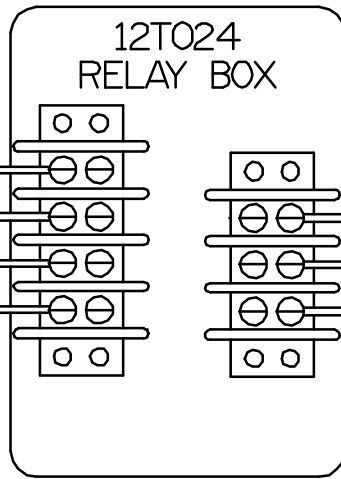
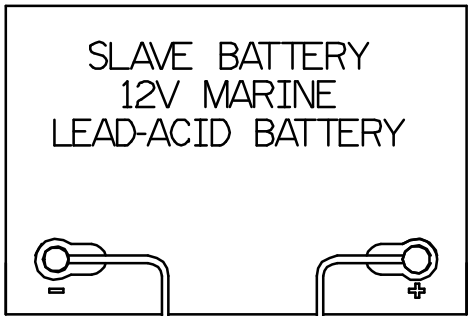

1ST RELAY  
BOX

TWO (2) REEL  
DIAGRAM

(1) RELAY BOX & (1) SLAVE BATTERY  
REQUIRED FOR EACH REEL

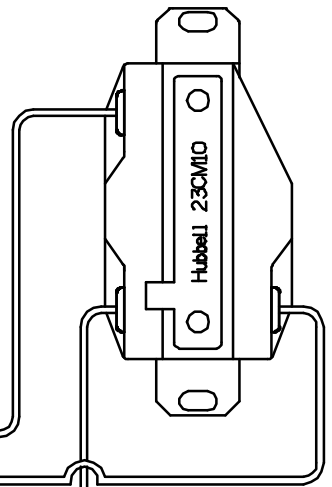
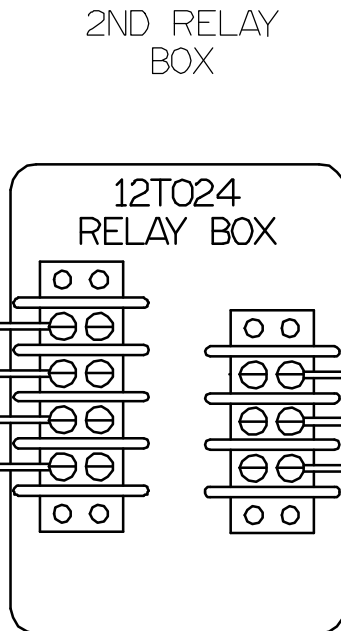
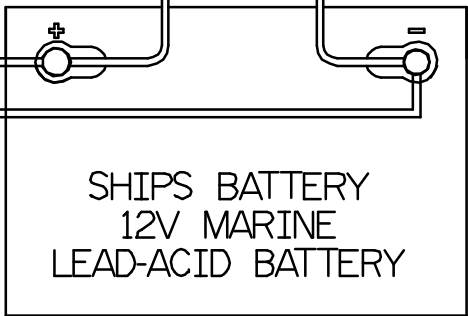

2ND RELAY  
BOX

