

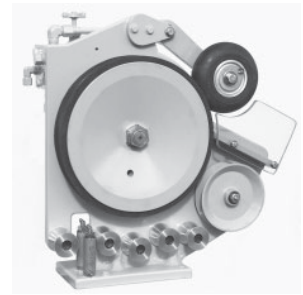

# LINDGREN-PITMAN, INC.

## LS-3 / LS-4 Line Setter



### MOUNTING

The Lindgren-Pitman Line Setter should be mounted on or near the transom of the boat such that the line will fall overboard as it leaves the exit. The line setter may be mounted from the deck with optional mounting stand or mounted to existing rigging if available.

### HYDRAULIC REQUIREMENTS

10 GPM 1000 PSI Maximum operating requirements

\* The hydraulic source must be stable and uninterrupted. Additional equipment operating on this circuit may cause pulsations unacceptable for smooth line setter operation. Hydraulic pulsations may cause the line to escape from the rollers and contribute to accelerated roller wear.

### Hydraulic Diagrams

#### Operating with Spool Pump

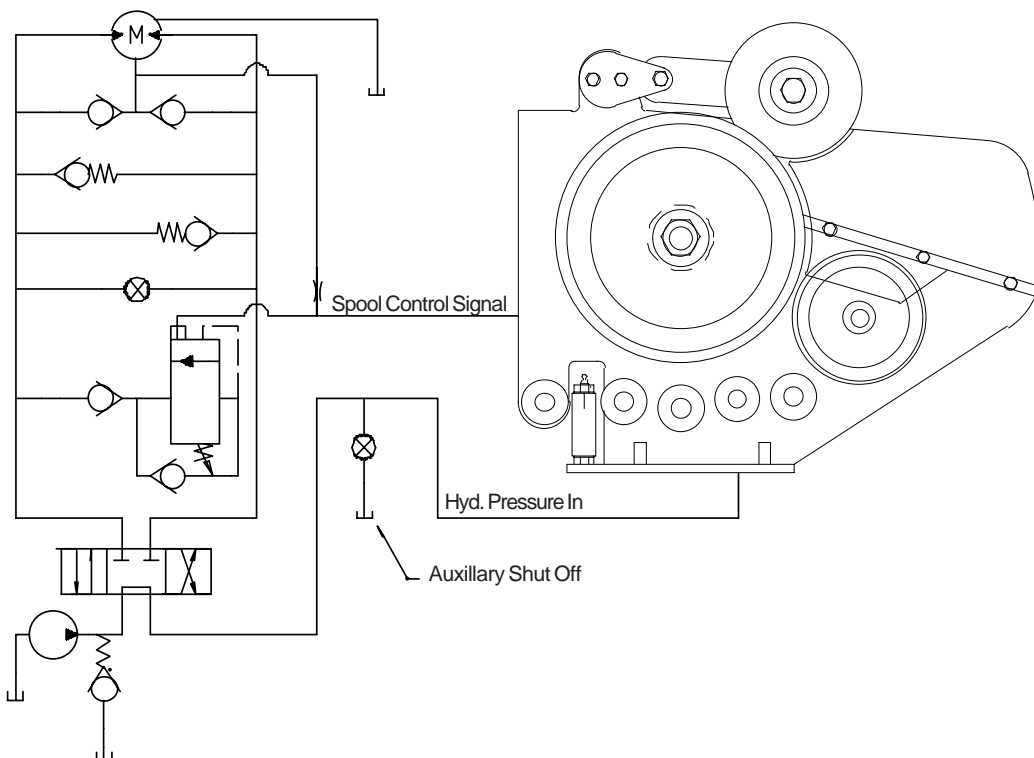

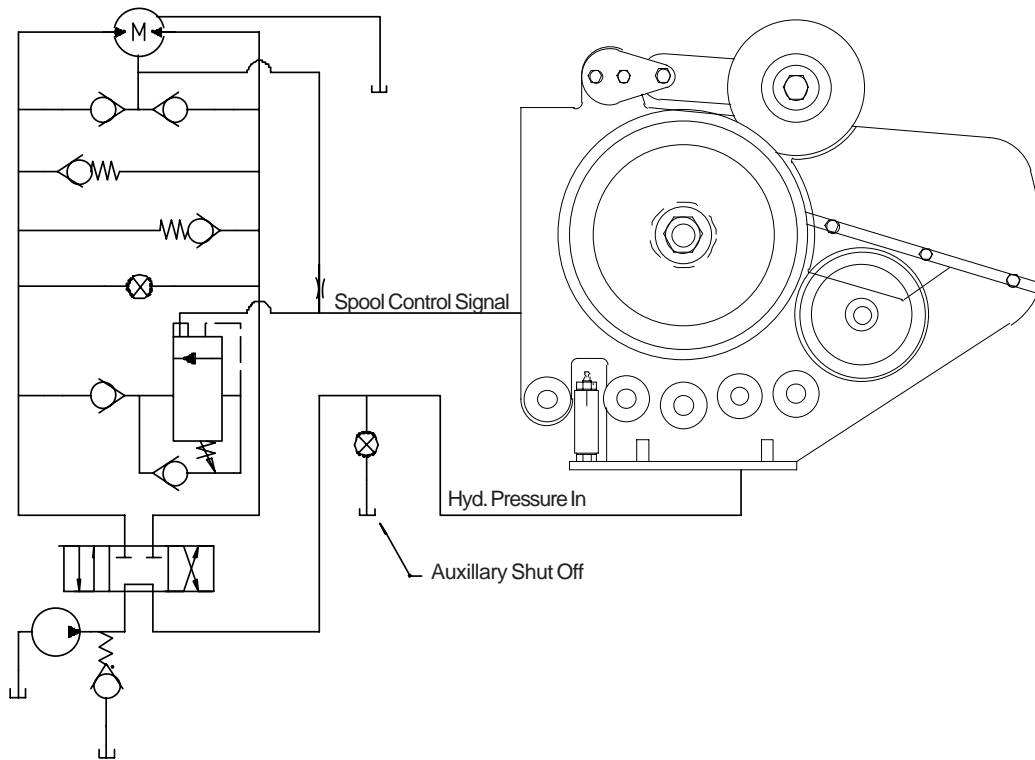

**FREESPOOLING THE MAIN LINE STORAGE SPOOL** Correct freewheeling conditions are normally obtained by utilizing a Lindgren-Pitman direct drive monofilament long line drum with a line setter pilot input circuit installed at the factory. Lindgren-Pitman monofilament type long line spools not factory supplied with this circuit can be field retrofitted. The circuit is as follows: Monofilament long line spools with drives not similar to Lindgren-Pitman equipment may or may not work properly with a line setter.

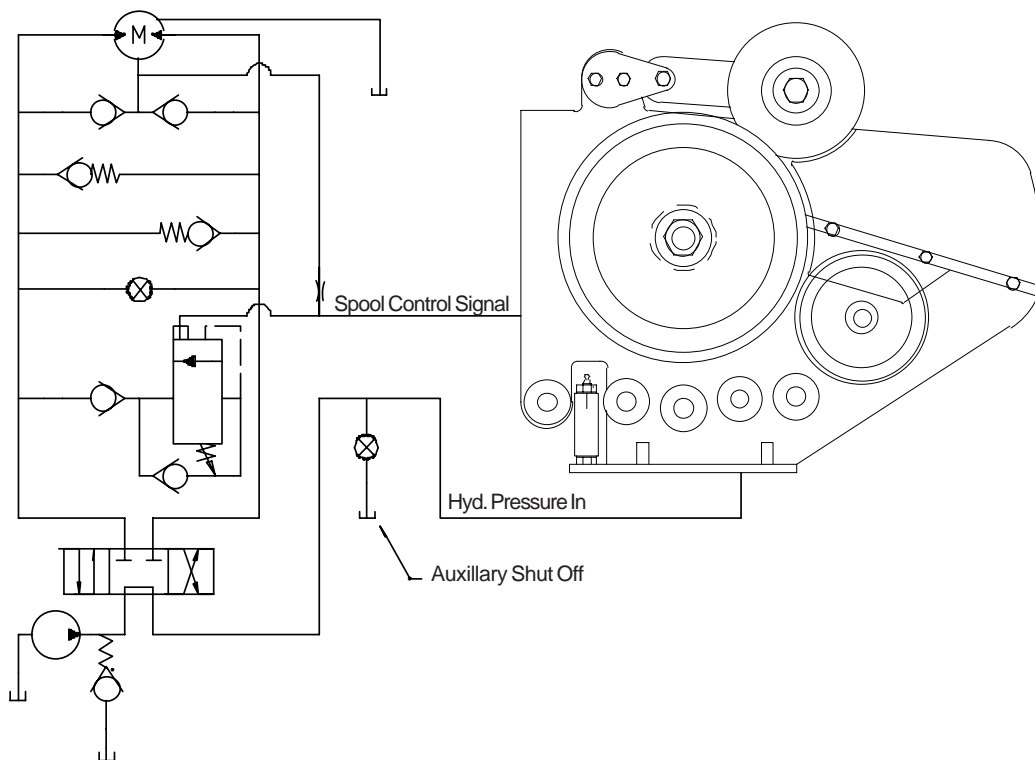

The main line storage spool must freespool easily and smoothly for the line setter to operate properly. The following requirements should be met:

1. Freespooling should not require more than 50 lbs. pull by the line setter at any spool diameter and at any operating speed. Excessive freespooling force will cause accelerated roller wear.
2. Sufficient drag must be present to prevent backlashing.
3. Sufficient fleet angle from the spool to any block or the line setter is necessary to provide smooth freespooling.

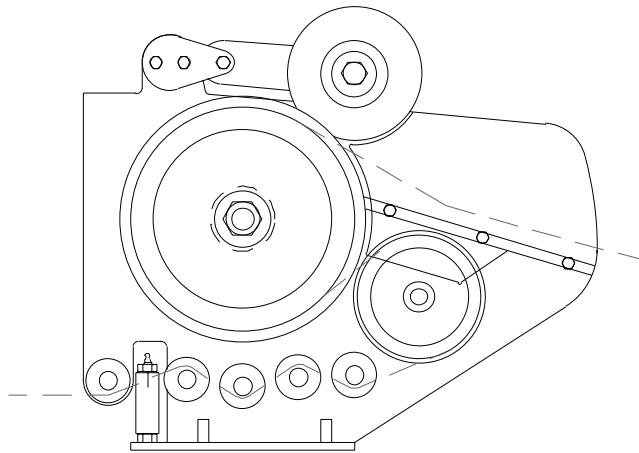

### START UP

Freespool or unwind enough main line to thread the line setter. Thread the line in the bottom between the two vertical input rollers, under the first hour glass roller and continuing over and under each consecutive roller to the exit.

Set the speed control to the OFF (closed) position. Make sure that the main spool freespool valve is in the off or closed position. Slowly close the on / off valve to start the setter. The speed can now be increased to the desired setting by opening the speed adjustment valve. Opening the on /off valve will shut off the line setter. With the line setter pilot control circuit installed on the main spool the line setter when loaded will freespool the main line spool automatically. It will also brake the main spool when necessary.

### ATTACHING SNAPS

Attach snaps at least one foot away from line setter exit. Use a downward motion when attaching a snap or grabbing the line. Impeding the line near the exit may cause the line to jump off the internal drive rollers.

## CONTROLS

### Power

The pulling power of the line setter can be preset at the line setter. It is controlled by a pressure relief valve across the motor hydraulic circuit. Loosening the jam or locking nut will allow for rotating the large set screw type adjustment cap. Clockwise rotation will increase the pressure and pulling power and counter clockwise will decrease the pressure and pulling power of the line setter. The pressure should be adjusted such that the drive motor does not have sufficient power to slip the drive wheel but high enough to pull line from the spool at sufficient speed. If slipping occurs the drive roller and the line will be damaged. Pressure factory set at 1000 PSI.

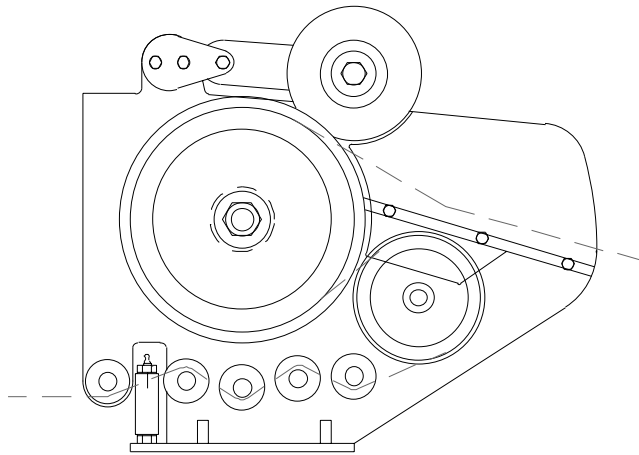

### Speed

The line setter has a speed control mounted on the unit. The speed can be adjusted faster or slower to obtain the desired line set. If sufficient speed cannot be obtained check for the following:

- a. Hydraulic source has sufficient volume
- b. Storage spool freewheels easily
- c. Power control adjusted to a sufficient pressure

### Speed Indicator (optional]

The Lindgren-Pitman line setter has a speed indicator programmed to display the line exit speed in knots and tenths of a knot. It is powered by the magnetic pickup and requires no external power. With the use of an extension cable from the magnetic pick up to the display unit it can be remote mounted.

The optional digital readout should display the line exit speed to the nearest tenth of a knot whenever the drive wheels operate with an update of approximately 1-2 seconds.

The depth of the line set is dependent upon the following factors:

1. Length of the buoy line.
2. The ratio of the line setter speed to the boat speed.

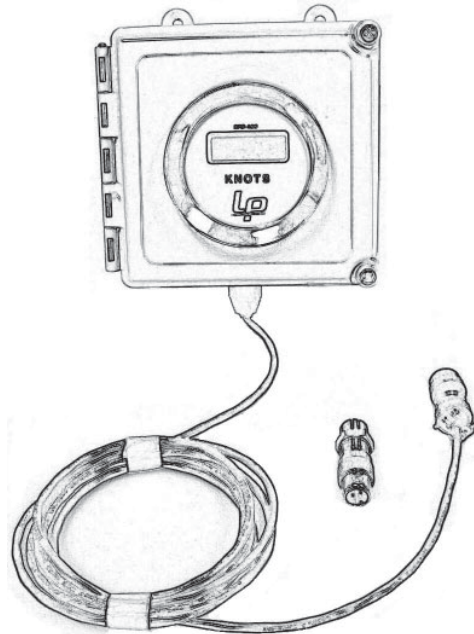

3. Distance between the buoys.
4. Length of the leader line.

The chart in the appendix will approximate the line depth using these four factors:

#### Drive wheel replacement

The drive wheel rubber element will wear with use. When the line has worn a groove in the drive roller element such that the drive roller will no longer grip the line it must be replaced. To replace simply force the worn rubber drive element off by prying under it with a screw driver and discard. Install the new drive element noting that the tapered inner surface of the drive element and the outer surface of the drive wheel slope the same way.

## ADJUSTMENT PROCEDURE FOR LINDGREN-PITMAN SPOOLS USING LINE SETTERS

### “Counterbalance Adjustment”

The Main line spool manifold has a counterbalance valve across the motor ports. The P2 port on the line setter is connected to the signal port of this counterbalance. With the adjustment of the counterbalance full counterclockwise the pilot requires 1300 PSI before it will allow freespooling (if the line setter is set at 1000 PSI maximum freespooling will not be possible). With the counterbalance full clockwise adjustment it would require only 330 PSI before allowing freespooling. (This may not be enough for prevention of backlashing and sufficient braking).

The easy method to adjust the counterbalance is as follows:

- 1 Adjust the line setter power at approximately 1000 PSI, but not above 1300 PSI. Check pressure at the signal line or pressure input with line threaded through the line setter and the line tied off to prevent rotation.
- 2 Thread line from the spool through the line setter by opening the ball valve on the spool.
- 3 Adjust the counterbalance full counterclockwise and close the ball valve.
- 4 Turn on the line setter slowly and let it pull on the spool line. The spool may not turn.
- 5 Turn the adjustment screw on the spool counterbalance slowly clockwise until the spool begins to freewheel. Continue to adjust clockwise until the line setter reaches its set speed.

Further continued setting of the line may require the counter-balance to be rotated a little more clockwise and as the spool diameter decreases. Usually a compromise setting can be found that runs smoothly with good-braking for the entire set.

The further clockwise setting of the counterbalance will freespool with less line setter pull, but also with less braking for slow down and stop.

# INSTRUCTIONS for adjusting the COUNTER BALANCE CARTRIDGE

Used to set desired line tension  
between linesetter and main spool.

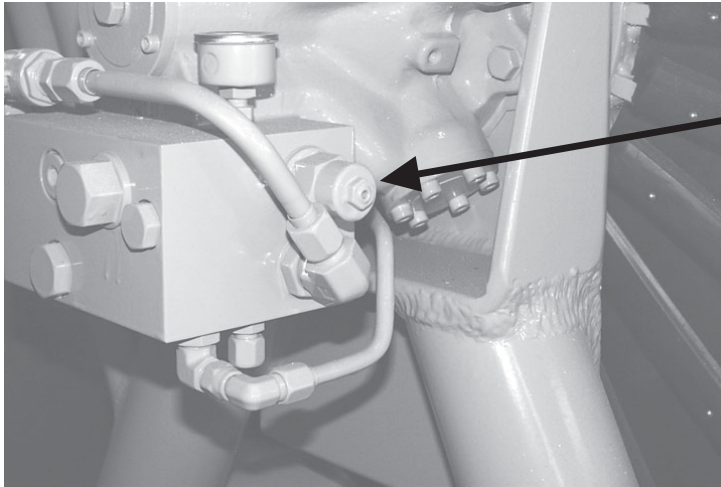

*Counter Balance Cartridge  
Adjusting Screw  
and Jam Nut*

The **Counter Balance Cartridge** is located on the main spool motor manifold. It controls the amount of line tension between the LS-3 LineSetter and the main spool.

**To adjust:** Loosen the jam nut and turn the socket head screw with a hex tool.

To **loosen** line tension. Rotate the adjusting screw **clockwise**.

To **tighten** line tension. Rotate the adjusting screw **counter-clockwise**.

When desired setting is acquired, **re-tighten** the **jam nut**.

**NOTE:** This adjustment also controls the hauling power of the reel. To increase power, rotate the adjusting screw counter-clockwise, rotating the adjusting screw clockwise decreases power.

**NOTE:** Some fishermen feel the need to adjust the Counter Balance Cartridge once or twice during a line setting operation, though after a period of time, a single setting should be achieved.



**IMPORTANT:** Use of the Freespool Ball Valve to further loosen the line tension beyond the Cartridge settings will not damage the equipment, however, by opening the Ball Valve, the stopping feature of the main spool will be partially or totally eliminated if the LineSetter is suddenly stopped.

# Hook Depth Calculation Chart

For Use With Lindgren-Pitman LS-Series Line Setters

To find the line setter speed setting, you must know the distance between float buoys and the desired sag of the main line between those floats.



- 1) Divide the desired sag by the distance between floats,
- 2) Find the ratio in column A,
- 3) Multiply the boat speed by the factor from column B.

Example:

With a distance of 1,800 feet between float buoys and a desired additional main line sag of 150 feet, the calculations would be made as follows.

150' desired sag (divided by)  
 1,800' distance between floats  
 equals .08. Locate .08 in the chart from  
 column A, then multiply column B by the  
 boat speed which is 8 knots.  
 $1.017 \times 8 \text{ (knots)} = 8.14 \text{ knots.}$

This is the speed setting on the line setter.

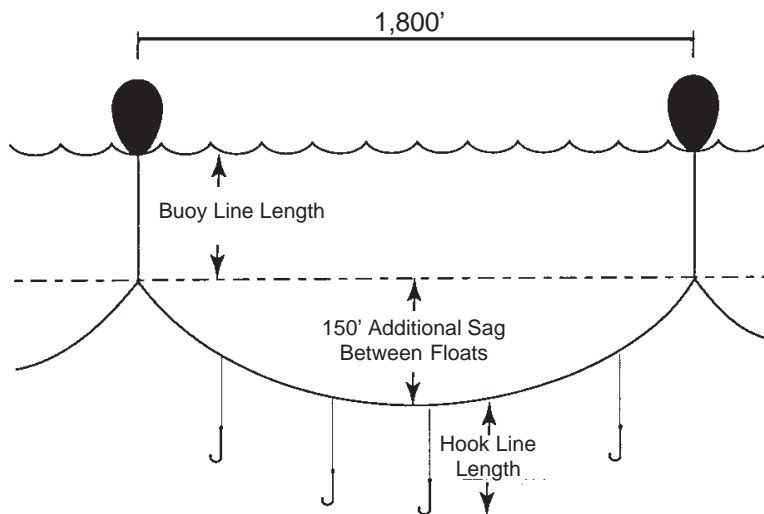

| A          | B            | A   | B     | A   | B     | A   | B     | A   | B     |
|------------|--------------|-----|-------|-----|-------|-----|-------|-----|-------|
| .01        | 1.000        | .11 | 1.032 | .21 | 1.114 | .31 | 1.239 | .41 | 1.401 |
| .02        | 1.001        | .12 | 1.038 | .22 | 1.124 | .32 | 1.254 | .42 | 1.419 |
| .03        | 1.002        | .13 | 1.044 | .23 | 1.136 | .33 | 1.269 | .43 | 1.437 |
| .04        | 1.004        | .14 | 1.051 | .24 | 1.147 | .34 | 1.284 | .44 | 1.455 |
| .05        | 1.007        | .15 | 1.059 | .25 | 1.159 | .35 | 1.300 | .45 | 1.474 |
| .06        | 1.010        | .16 | 1.067 | .26 | 1.171 | .36 | 1.316 | .46 | 1.493 |
| .07        | 1.013        | .17 | 1.075 | .27 | 1.184 | .37 | 1.332 | .47 | 1.512 |
| <b>.08</b> | <b>1.017</b> | .18 | 1.084 | .28 | 1.197 | .38 | 1.349 | .48 | 1.531 |
| .09        | 1.021        | .19 | 1.094 | .29 | 1.211 | .39 | 1.366 | .49 | 1.551 |
| .10        | 1.026        | .20 | 1.103 | .30 | 1.225 | .40 | 1.383 | .50 | 1.571 |





# Longline Spool Hydraulic Manifold with Line Setter

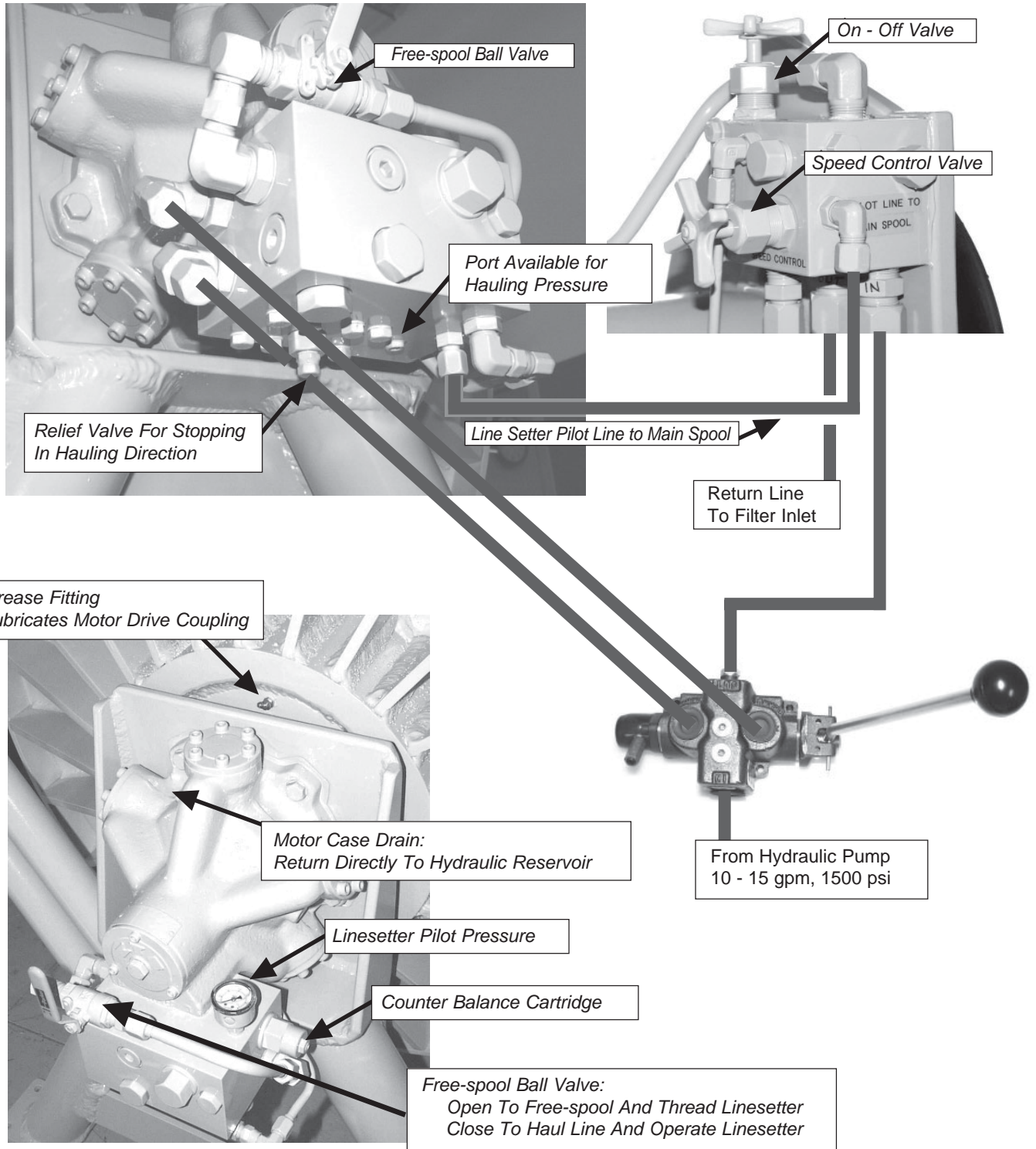



# LINDGREN-PITTMAN Longline Spool Hydraulic Circuit Connections

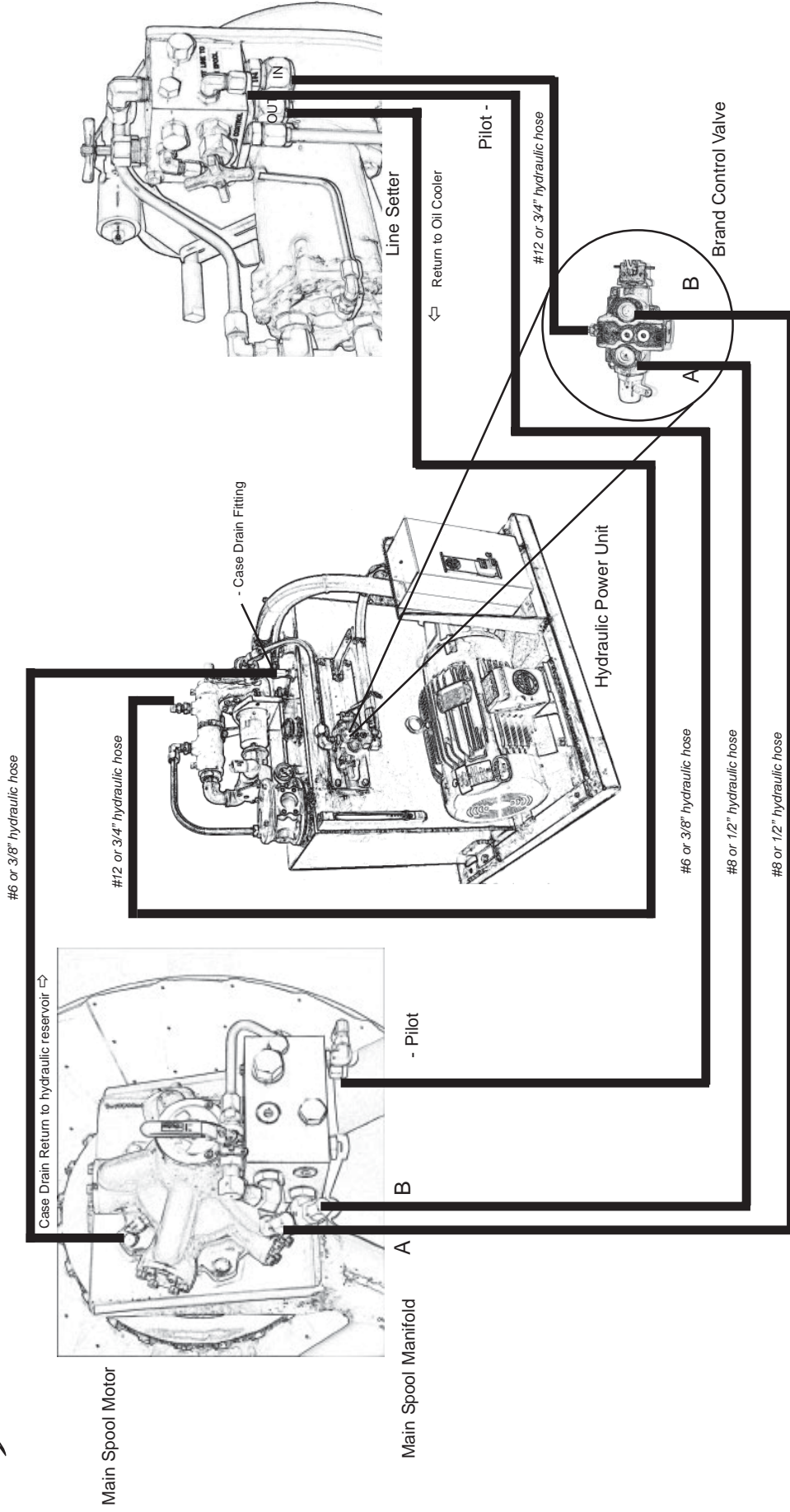



# Line Setter Hydraulic Manifold

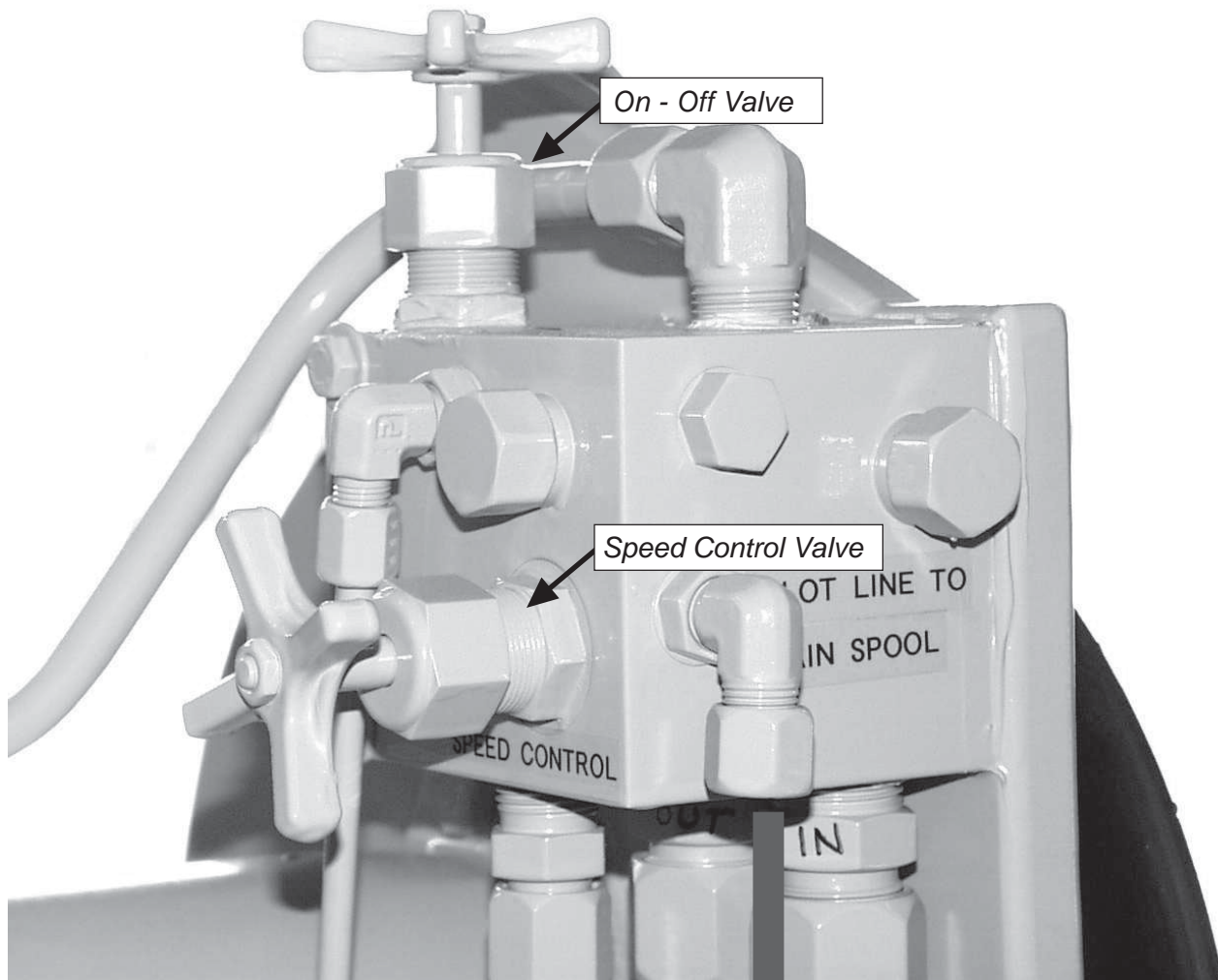

Line Setter Pilot Line to Main Spool

Return Line  
To Filter Inlet

In From Main Spool  
Control Valve

# Parts List

| Item            | Qty. | Item I.D.  | Description  |
|-----------------|------|------------|--|
| 1               | 1    | 74624-2204 | Drive Shaft - Stainless Steel                                      |
| 2               | 1    | 74624-305  | Backplate Assembly   |
| 3               | 1    | 74624-307  | Housing Assembly   |
| 4               | 1    | 74614-50   | Rotating Kit Assembly  |
| 5               | 1    | 16009-118  | Retaining Ring   |
| 6               | 1    | 160015-57  | O-ring, 2,37 mm Dia. x 114,3 mm ID. [.0937 in. Dia. x 4.5 in. ID.] |
| 7               | 1    | 74600-102  | Thrust Bearing   |
| 8               | 2    | 74600-600  | Pivot  |
| 9               | 1    | 74600-601  | Spider   |
| 10              | 1    | 74600-603  | Key  |
| 11              | 9    | 74604-5    | Piston   |
| 12              | 9    | 74604-10   | Piston Assembly  |
| 13              | 1    | 74604-59   | Connector Plate  |
| 14              | 1    | 74600-605  | Spacer   |
| 15              | 1    | 16232-16   | Shaft Seal   |
| 16              | 1    | 74600-100  | Bearing Race   |
| 17              | 1    | 74600-110  | Piston Race S/A  |
| 18              | 1    | 17140-1    | Spring   |
| 19              | 1    | 74600-614  | Pilot  |
| 20              | 1    | 74600-104  | Thrust Bearing   |
| 21              | 1    | 16241-D916 | Bearing Race   |
| 22              | 6    | 16032-510  | Cap Screws, 5/16-18, 25,4 mm [1 in.] Long                          |
| 23              | 1    | 16077-26   | Retaining Ring   |
| 24              | A/R  | 74600-103  | Thrust Race  |
| 36              | A/R  | 16048-616  | Washer   |
| 37              | A/R  | 74600-115  | Washer   |
| 38              | 1    | 74640-600  | Spring Collar  |
| Seal Repair Kit |      | 74640-901  | Seal Repair Kit - Ref. No.'s 5, 6 & 23                             |

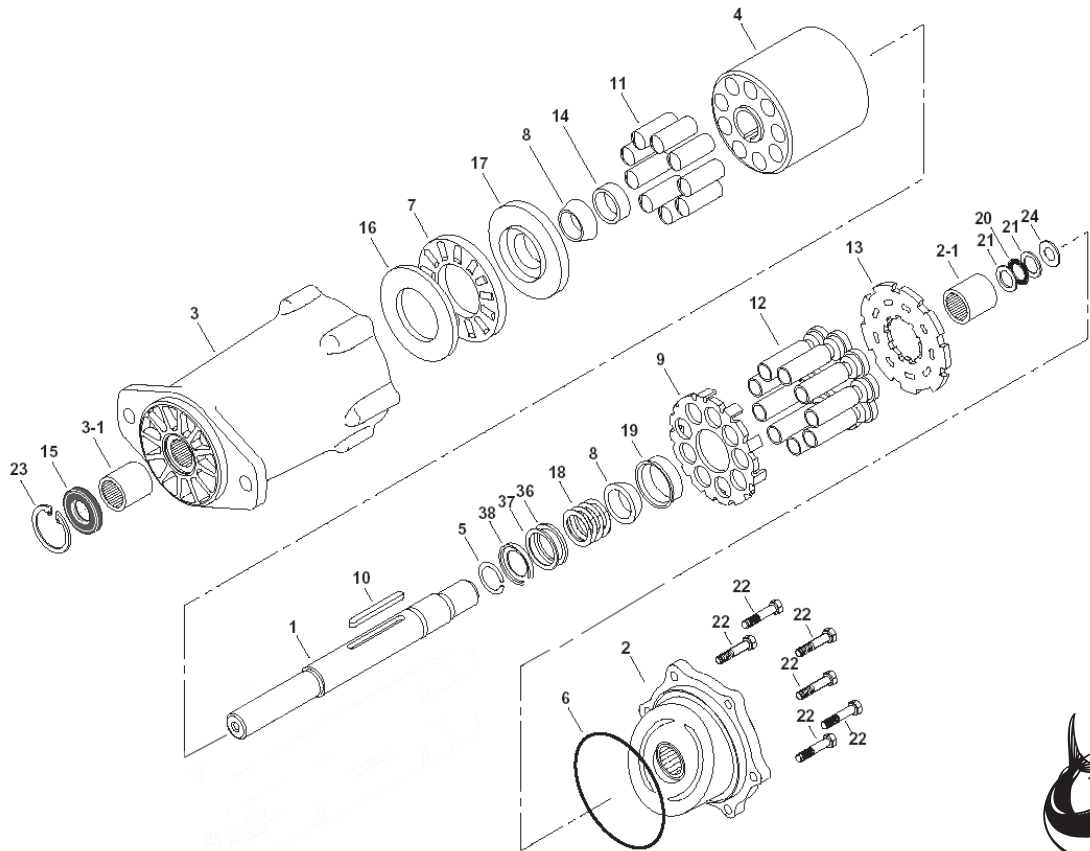



# LINDGREN-PITMAN, INC.

## Hydraulic Circuit

### Main Spool Manifold (Uniblock)

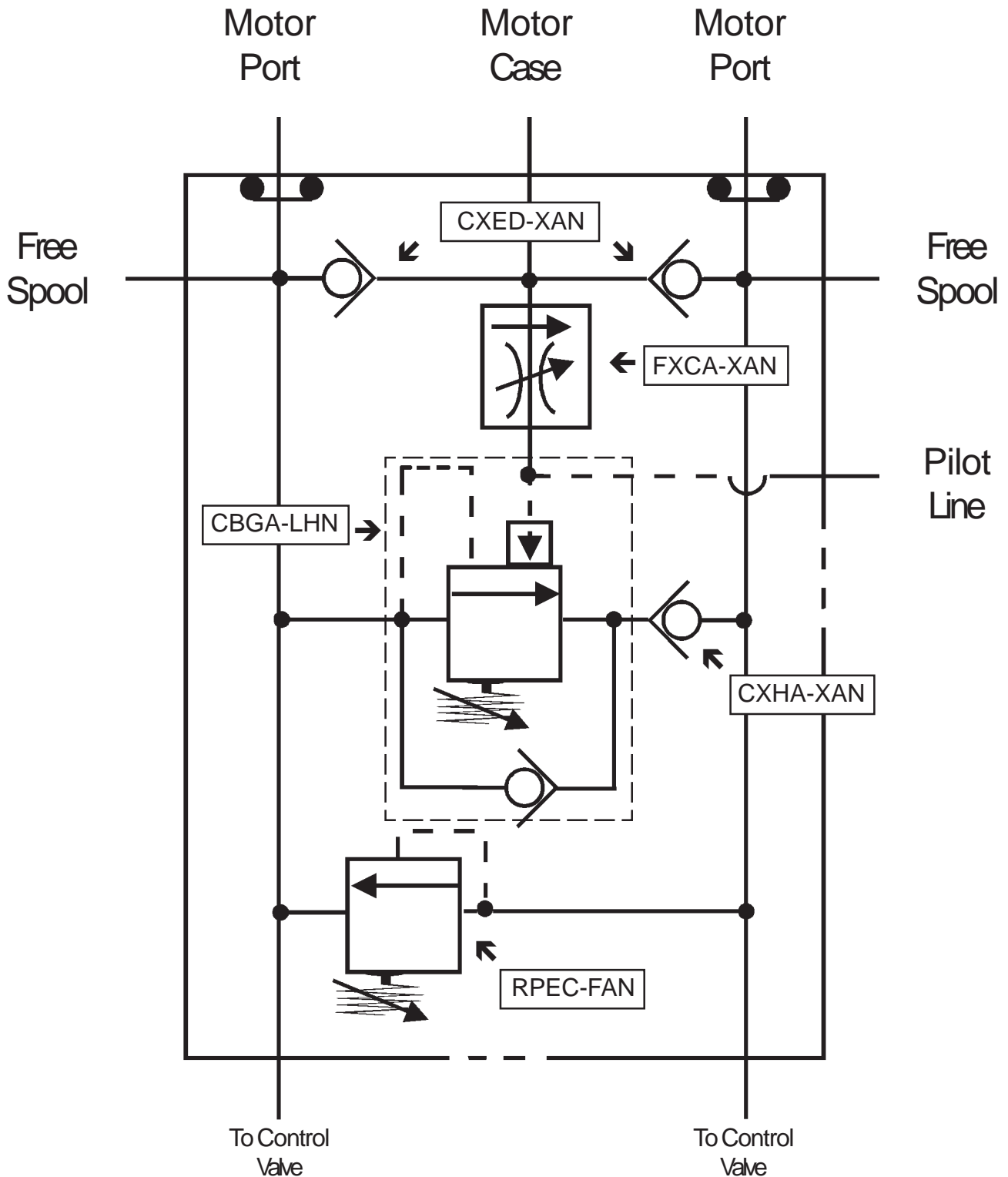



# LINDGREN-PITMAN, INC.

## Hydraulic Circuit Line Setter Manifold

