

THE TRILL TREMOLO (K-960)

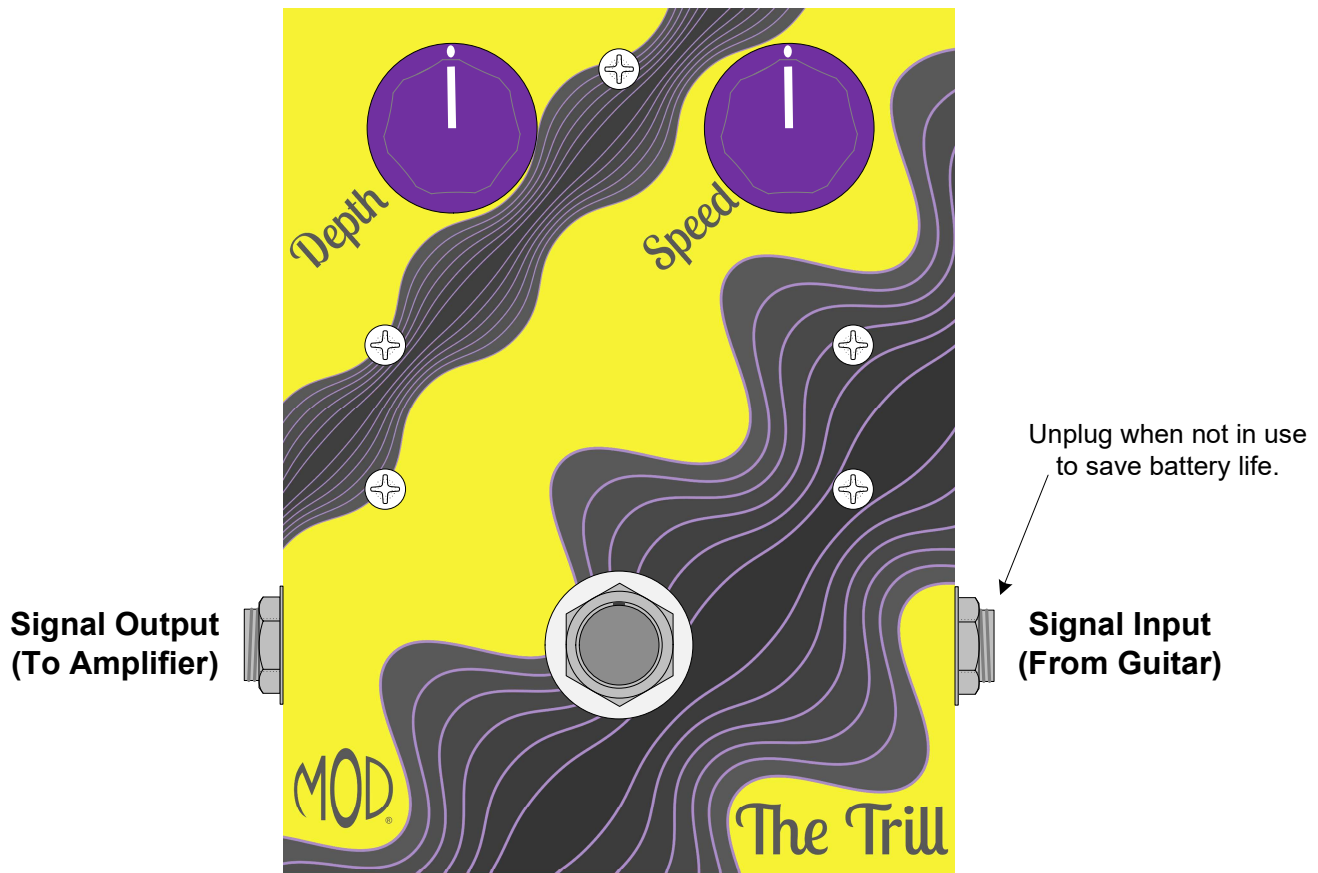

Use these instructions to learn:

- How to build an effects pedal for tremolo.

The Trill Tremolo pedal offers classic tremolo tones in an easy to build kit. The Speed knob provides a wide range from very slow to a rapid fire effect. The Depth knob varies the ratio between effected and dry signal. Using modern, low noise transistors makes operation of the Trill quiet with no signal drop when engaged as in some vintage style tremolo pedals.

Warning: This circuit was designed for use with a 9 VDC power supply only.



TABLE OF CONTENTS

TOOL LIST	2
PARTS LIST DRAWINGS.....	3, 4
FINAL ASSEMBLY REFERENCE DRAWING.....	5
SOLDERING TIPS	6
STEP BY STEP ASSEMBLY INSTRUCTIONS	7 - 10
Section 1 – Mount Potentiometers, Terminal Strips and Footswitch	7
Section 2 – Mount Input & Output Capacitors, ¼” Jacks and Wire the Footswitch	7
Section 3 – Strip, Tin and Connect the Remaining Wires	8
Section 4 – Mount the Components	9

ASSEMBLY DRAWINGS (6 Drawings)

11 - 13
These are the last 3 pages. They should be separated and used as a reference to help assemble the kit correctly.

TOOL LIST

- Wire Strippers
- Needle Nose Pliers
- Cutting Pliers
- Desoldering Pump
- Solder (60/40 rosin core)
- Soldering Station
- Phillips Head Screwdrivers
- Slotted tip screwdrivers (3 mm tip)
- Channellock Pliers (or similar type)
- Ruler
- Hobby Vise (or other means to secure box while working)
- Exacto knife or similar cutting tool

PARTS LIST 1

Stranded Wire (22 AWG) - Red
K-PUL1569 (3 FT)

Enclosure
P-H1590BBCE-DP (1)

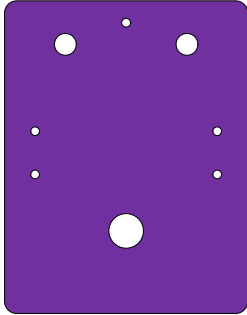

Knobs
P-K345-PUR (2)

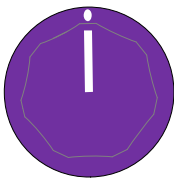

Battery Clip
S-H155 (1)

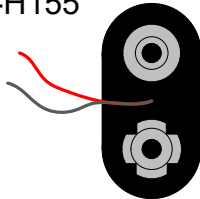

1/4" Mono Jack (Output Jack)
W-SC-11-T (1)

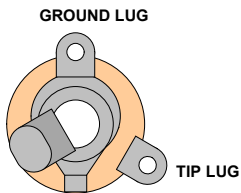

1/4" Stereo Jack (Input Jack)
W-SC-12B (1)

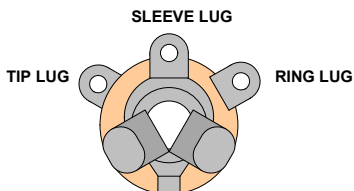

DPDT Foot Switch
P-H498 (1)

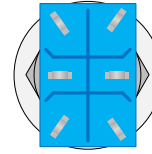

Potentiometers: 1ML and 250KL
R-VA1ML (1)
R-VA250KL (1)

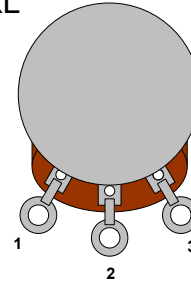

Terminal Strip with 5 Terminals
P-0501H01 (1)

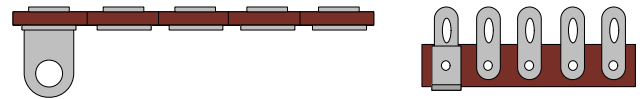

Terminal Strip with 8 Terminals
P-0802H (2)

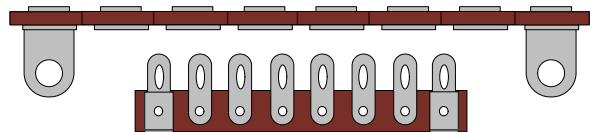

#4 Screw (1/4" long)
S-HS440-14 (5)

#4 Nut
S-HHN440 (5)

#4 Lock Washer
S-HLW4 (5)

PARTS LIST 2

NPN BJT (2N5088)

P-Q2N5088 (3)

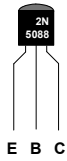

10 μ F Polarized Capacitor 50V

C-ET10-50 (1)



0.1 μ F Capacitor 100V

C-PEID1-100 (3)

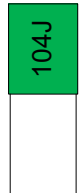

0.22 μ F Capacitor 100V

C-PEID22-100 (3)

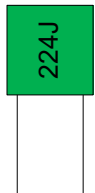

1M Ω Resistor 1/2 W

R-A1M (2)

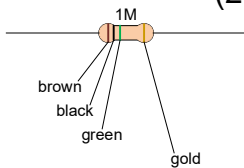

100k Ω Resistor 1/2 W

R-A100K (4)

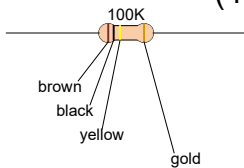

The Trill Sticker



(1)

1.5k Ω Resistor 1/2 W

R-A1D5K (1)

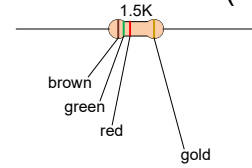

15k Ω Resistor 1/2 W

R-A15K (1)

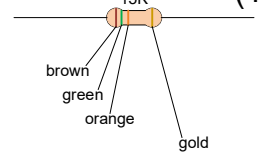

3M Ω Resistor 1/2 W

R-A3M (1)

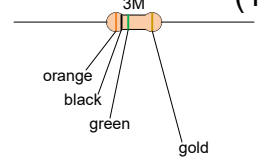

330k Ω Resistor 1/2 W

R-A330K (1)

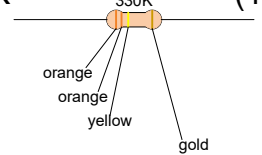

4.7k Ω Resistor 1/2 W

R-A4D7K (1)

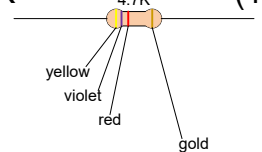

5.6k Ω Resistor 1/2 W

R-A5D6K (1)

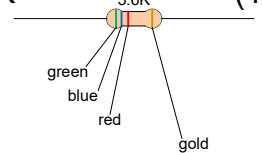

FINAL ASSEMBLY REFERENCE DRAWING

This is a large version of the final assembly drawing. Refer to this drawing as you make your way through each step of the instructions. Before you make a new connection at a particular terminal or solder lug, notice how many other connections will be made at that terminal. That way you can decide whether it's best for you to solder the connection and leave space open for future connections or hold off on soldering until after every connection at that location has been made.

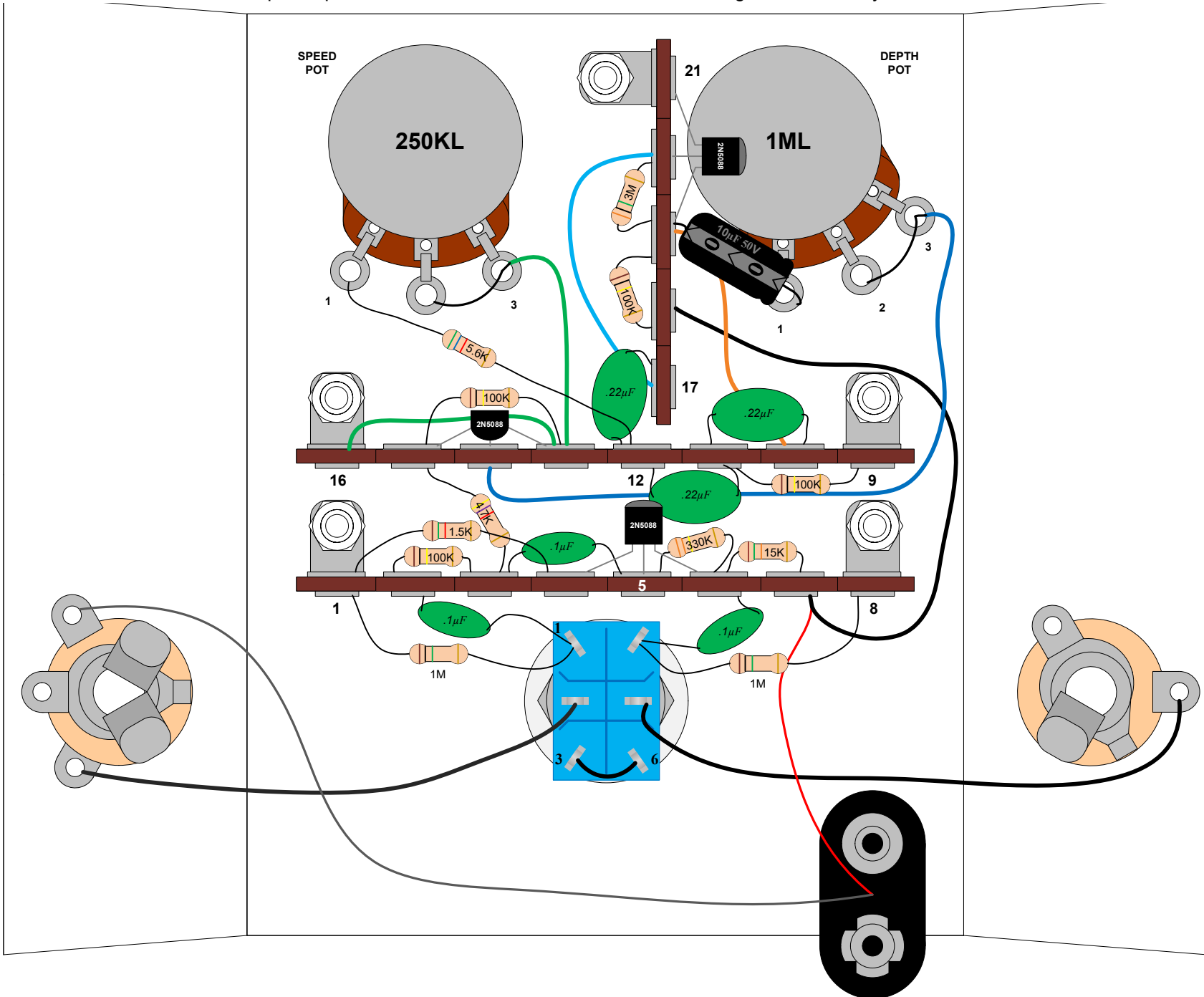

SOLDERING TIPS

It is important to make a good solder joint at each connection point. A cold solder joint is a connection that may look connected but is actually disconnected or intermittently connected. (A cold solder joint can keep your project from working.)

Follow these tips to make a good solder joint. *Take your time with each connection and make sure that all components are connected and will remain connected if your project is bumped or shaken.*

1. Bend the component lead or wire ending and wrap it around the connection point.
 - Make sure it is not too close to a neighboring component which could cause an unintended connection.
2. Wrap the component lead so that it can hold itself to the connection point.
3. Touch the soldering iron to both the component lead and the connection point allowing both to warm up just before applying the solder to them.
4. Be sure to adequately cover both component lead and connection point with melted solder.
 - Remove the soldering iron from your work and allow the solder joint to cool. (The solder joint should be shiny and smooth after solidifying.)
 - Cut off any excess wire or component leads with cutting pliers.
 - Clean the soldering iron's tip by wiping it across the wet sponge again after making the solder joint.

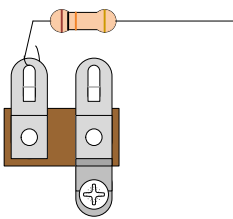

1. Bend the component lead and wrap it around the connection point.

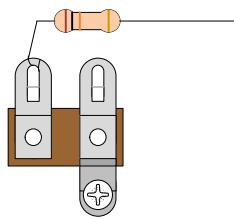

2. Wrap the component lead so that it can hold itself to the connection point.

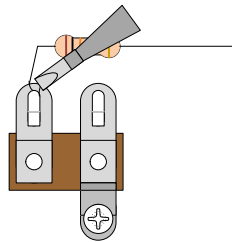

3. Heat up both component lead and connection point with the soldering iron.

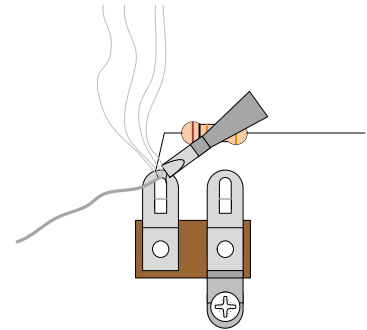

4. Apply solder to both component lead and connection point.

De-Soldering Tip

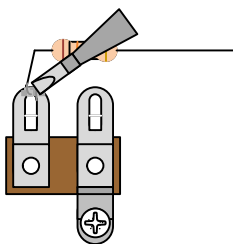

1. Heat up old solder joint with the soldering iron.

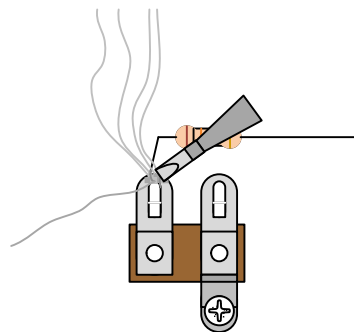

2. Apply fresh solder to mix in with old solder joint

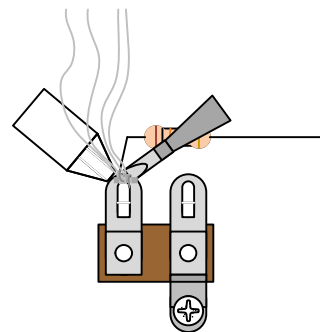

3. Use a de-soldering tool to remove the old solder joint while it is heated.

SECTION 1 – Mount Potentiometers, Terminal Strips and Footswitch

Please refer to **DRAWING 1** and **DRAWING 2**.

Orient the box with 1/2" hole nearest you.

Apply the sticker to the top of the box then use a blade to cut out the holes.

- Bend back and remove the alignment tab on the top of each potentiometer using a pair of pliers before mounting the pots so that they can mount flush against the enclosure surface.
- Mount the 1ML potentiometer in the 5/16" hole on the top right side of the box. Orient this pot so that lug "1" is pointing down toward the bottom of the box. Fasten the nut and tighten.
- Mount the 250KL pot in the 5/16" hole on the top left side of the box. Make sure that all three lugs are facing down toward the bottom of the box. Fasten the nut and tighten.

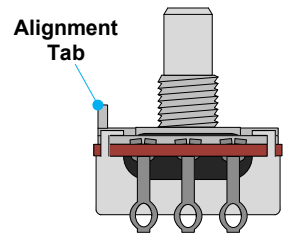

- Using the hardware provided, mount the terminal strips as shown in DRAWING 2. The lock washers go underneath each respective hex nut for a tight grip.

Please note that each terminal has been numbered as illustrated in DRAWING 2 and will be referred to as a "Terminal #_" when connecting different components and wires throughout the assembly instructions.

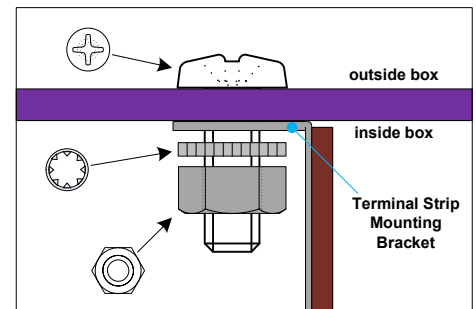

- Mount the footswitch in the 1/2" hole as shown in DRAWING 2 using hardware provided. The large nylon washer goes under mounting nut on the outside of the box. The lock washer mounts on the inside between the box surface and the other nut. Make sure the footswitch solder lugs are oriented as shown in the drawing.

SECTION 2 – Mount Input & Output Capacitors, 1/4" Jacks and Wire the Footswitch

Please refer to **DRAWING 3**.

Unless noted otherwise, "connect" means to trim the component's leads to a reasonable length, wrap them tightly around their connection points and solder. (See "Soldering Tips" on page 5).

You might find it easier to mount the capacitors upside-down with the insulated top end of each cap touching the enclosure surface.

- Connect one of the 0.1µF capacitors from Lug "1" of the footswitch to Terminal #2 as shown in DRAWING 3.
- Connect one of the 1M resistors from Lug "1" of the footswitch to Terminal #1.
- Connect another 0.1µF capacitor from Lug "4" of the footswitch to Terminal #6 as shown.
Only solder the connection at Lug "4" at this point. (There will be three more components connected to Terminal #6).
- Connect the other 1M resistors from Lug "4" of the footswitch to Terminal #8.
- Mount the input jack in the 3/8" hole on the left side of the box. The washer goes under the nut on the outside of the box. Make sure to center the "ground" lug of the input jack so that it is facing up towards the enclosure opening. This will make soldering the connections easier.

- Mount the output jack in the 3/8" hole on the right side of the box. Make sure the "tip" lug of the input jack is facing up towards the enclosure opening.

Stripping and tinning wire and soldering. Throughout these instructions you will be told to strip and tin a length of wire numerous times. Unless noted otherwise, cut the wire to the length stated in the instructions. Then strip 1/4" of insulation off each end. Twist each end of the stranded wire, and apply a small amount of solder to each end (tin the wire ends). This will prevent the stranded wire from fraying and will make the final soldering much easier.

- Strip and tin a 1 1/2" piece of wire and connect footswitch lug "2" to input jack "tip" lug.
- Strip and tin a 1 1/2" piece of wire and connect footswitch lug "5" to output jack "tip" lug.
- Strip and tin a 1 1/2" piece of wire and connect footswitch lugs "3" and "6" to each other.
Push this wire down so that it rests against the back of the switch. This should be done to provide an insulating barrier between the 9 volt battery and the terminals of the footswitch.
- Locate the battery clip. Twist its leads together a few times and connect the black lead to the ring lug of the input jack. Connect the red lead to Terminal #7 as shown in DRAWING 3.

SECTION 3 – Strip, Tin and Connect the Remaining Wires

Please refer to DRAWING 4.

Wire leads should be routed as close to the bottom of the box as possible in order to make mounting the components easier later in the assembly process. Consider making wire connections to the lower terminal holes and leaving the upper part of the terminals for component connections.

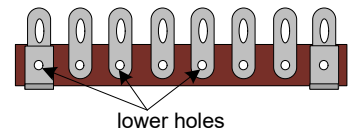

- Strip and tin a 4" piece of wire and connect Terminals #7 and #18 to each other.
- Strip and tin a 4 1/2" piece of wire. Strip 1/2" of insulation off of one end and use it to connect the 1ML pot lugs "2" and "3" to each other. Connect the other wire end to Terminal #14.
- Strip and tin a 2 1/4" piece of wire and connect Terminals #10 and #19 to each other.
- Strip and tin a 2" piece of wire. Strip 1/2" of insulation off of one end and use it to connect the 250KL pot lugs "2" and "3" to each other. Connect the other wire end to Terminal #13.
Only solder the pot lug connections at this point. (Terminal #13 will have another wire connected next).
- Strip and tin a 2 1/2" piece of wire and connect Terminals #13 and #16 to each other.
- Strip and tin a 2 1/2" piece of wire and connect Terminals #17 and #20 to each other.

SECTION 4 – Mount the Components

Please refer to DRAWING 5.

- Connect the 1.5K resistor to Terminals #1 & #4.

- Connect a 100K resistor to Terminals #2 & #3.

Only solder the connection at Terminal #2 at this point. (There will be two more components connected to Terminal #3).

- Connect the 0.1 μ F capacitor to Terminals #3 & #5.

Don't solder these connections, yet. (There will be one more component added to #3 and two more added to #5).

- Connect the 4.7K resistor to Terminals #3 & #15.

Only solder the #3 connection, now. (There will be two more component added to #15).

- Mount one 2N5088 transistor to Terminals #4, #5 and #6.

Only solder the #4 connection, now. (There will be more components added to #5 and #6).

Terminals #4: Emitter

Terminals #5: Base

Terminals #6: Collector

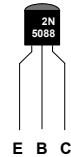

- Connect the 330K resistor to Terminals #5 & #6.

Only solder the #5 connection, now. (There will be one more component added to #6).

- Connect the 15K resistor to Terminals #6 & #7.

- Connect a 0.22 μ F capacitor to Terminals #11 & #12.

Do not solder these connections, yet. (There will be two more components added to each terminal).

- Connect another 0.22 μ F capacitor to Terminals #10 & #11.

Only solder the #10 connection, now. (There will be one more component added to #11).

- Connect the remaining 0.22 μ F capacitor to Terminals #12 & #17.

Only solder the #17 connection, now. (There will be one more component added to #12).

- Connect a 5.6K resistor to Terminal #12 & 250KL pot lug "1".

- Mount another 2N5088 transistor to Terminals #13, #14 and #15.

Only solder the #14 connection, now. (There will be one more component added from #13 to #15).

Terminals #13: Emitter

Terminals #14: Base

Terminals #15: Collector

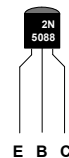

- Connect a 100K resistor to Terminals #13 & #15.

- Connect another 100K resistor to Terminals #18 & #19.

Only solder the #18 connection, now. (There will be three more components added to #19).

- Connect the 3M resistor to Terminals #19 & #20.

Do not solder these connections, yet. (There will be more components added to each terminal).

- Mount another 2N5088 transistor to Terminals #19, #20 and #21.

Only solder the #20 & #21 connections, now. (There will be one more component added to #19).

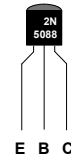

Terminals #21: Emitter

Terminals #20: Base

Terminals #19: Collector

- Connect the 10 μ F capacitor with its positive (+) lead at the 1ML pot lug "1" and its negative (-) lead at Terminal #19.



- Connect the remaining 100K resistor to Terminals #9 & #11.

DRAWING 6 offers an enlarged view of the terminal strip components to help with double-checking your work.

Finish it off by double-checking all of your connections, connect and insert a 9V battery, screw the lid on and fasten the knobs to both pot shafts.

DRAWING 1

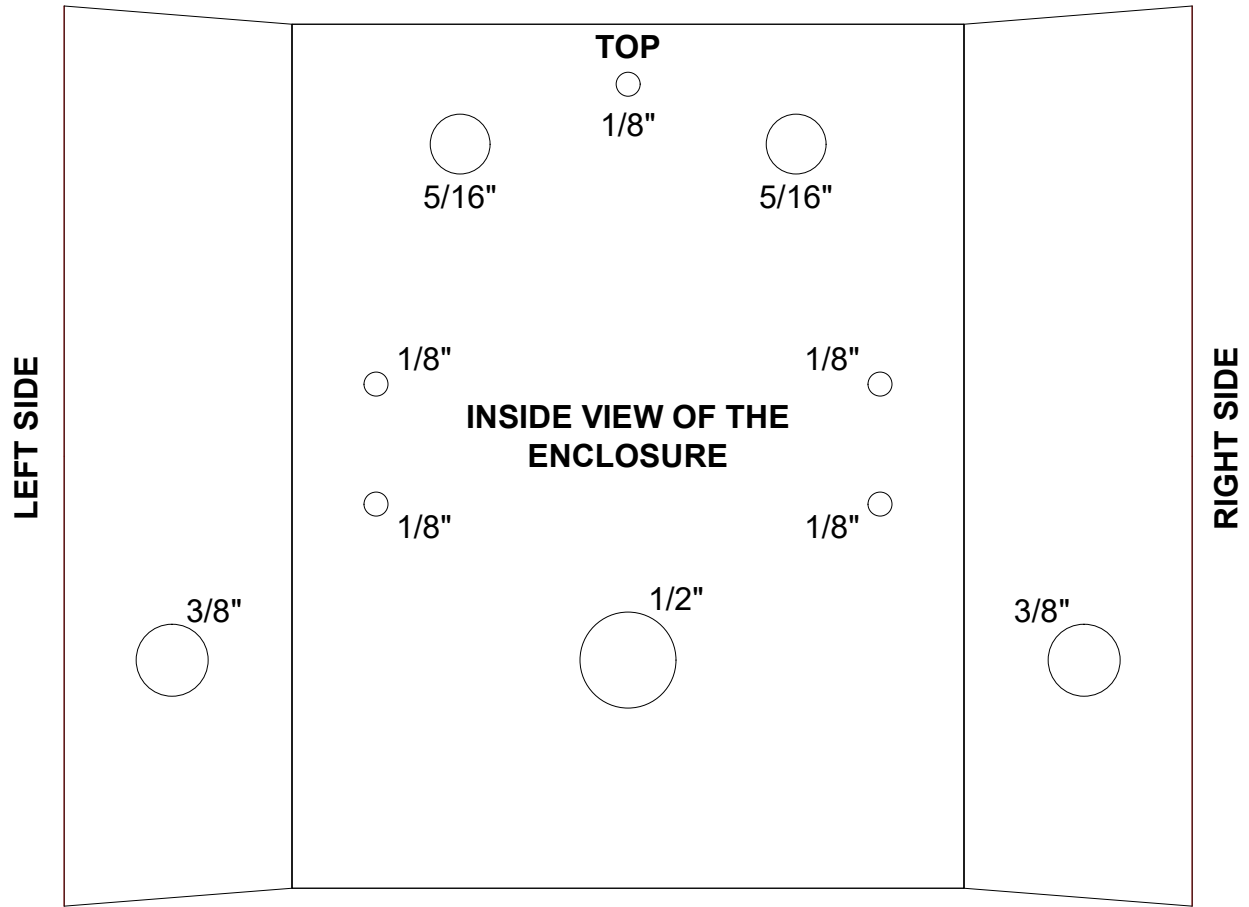

DRAWING 2

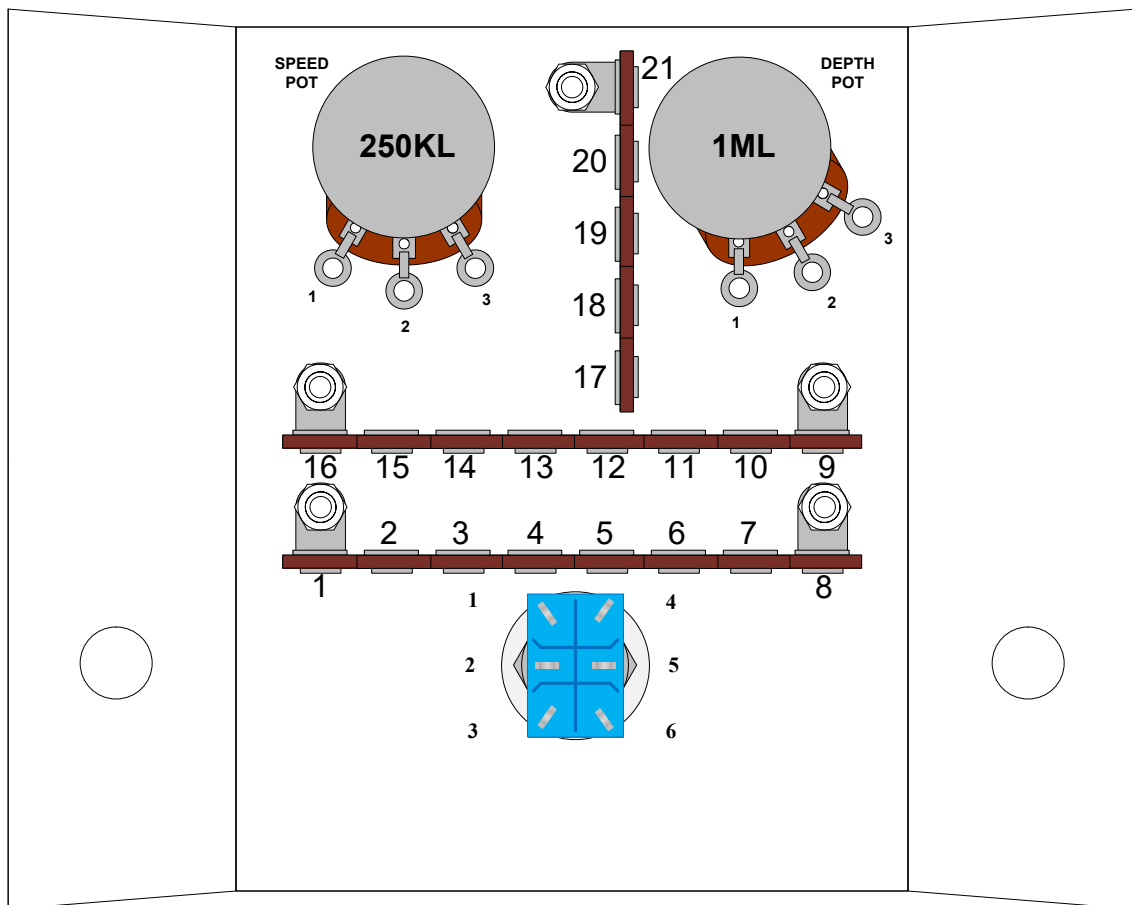

DRAWING 3

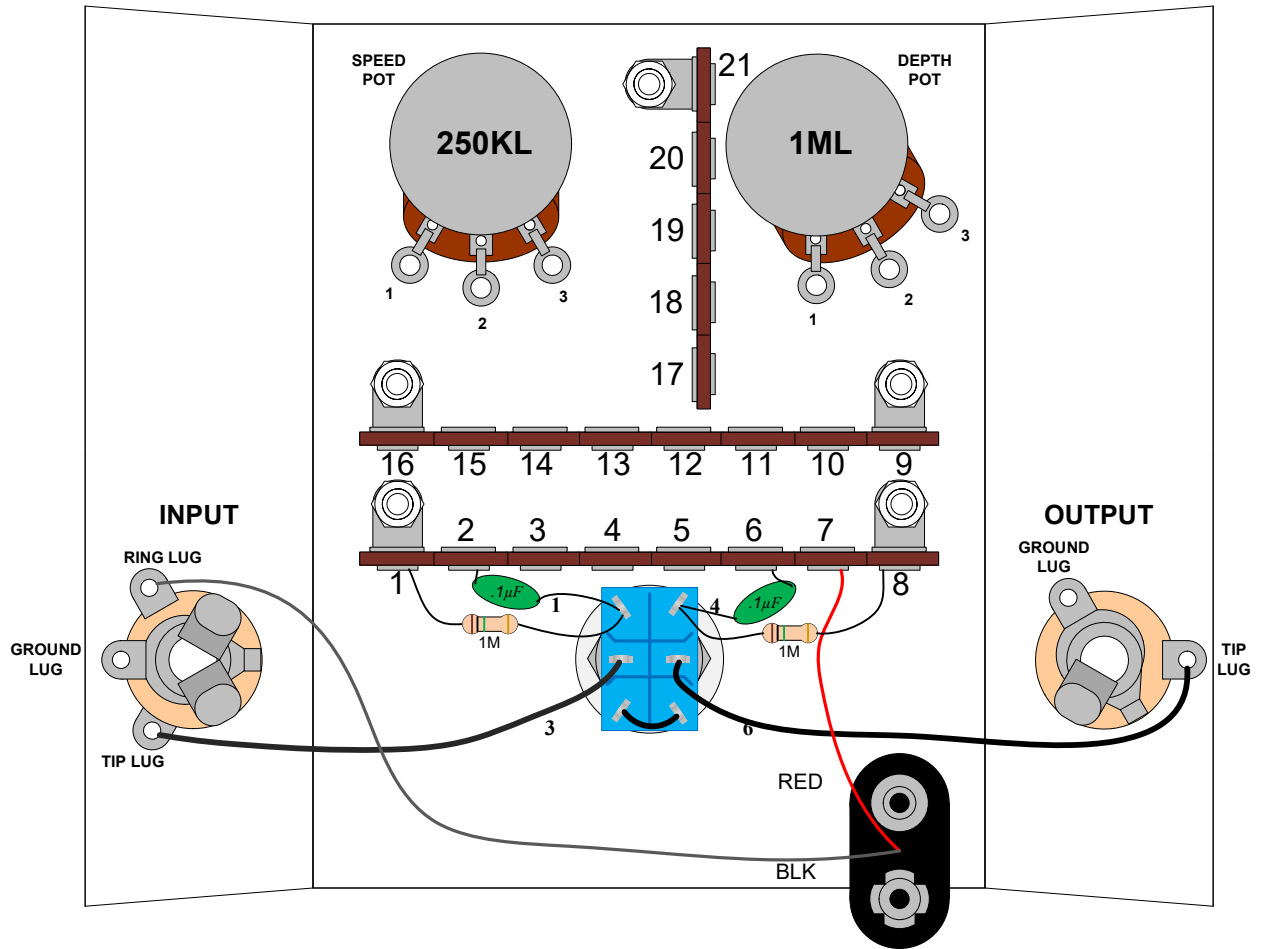

DRAWING 4

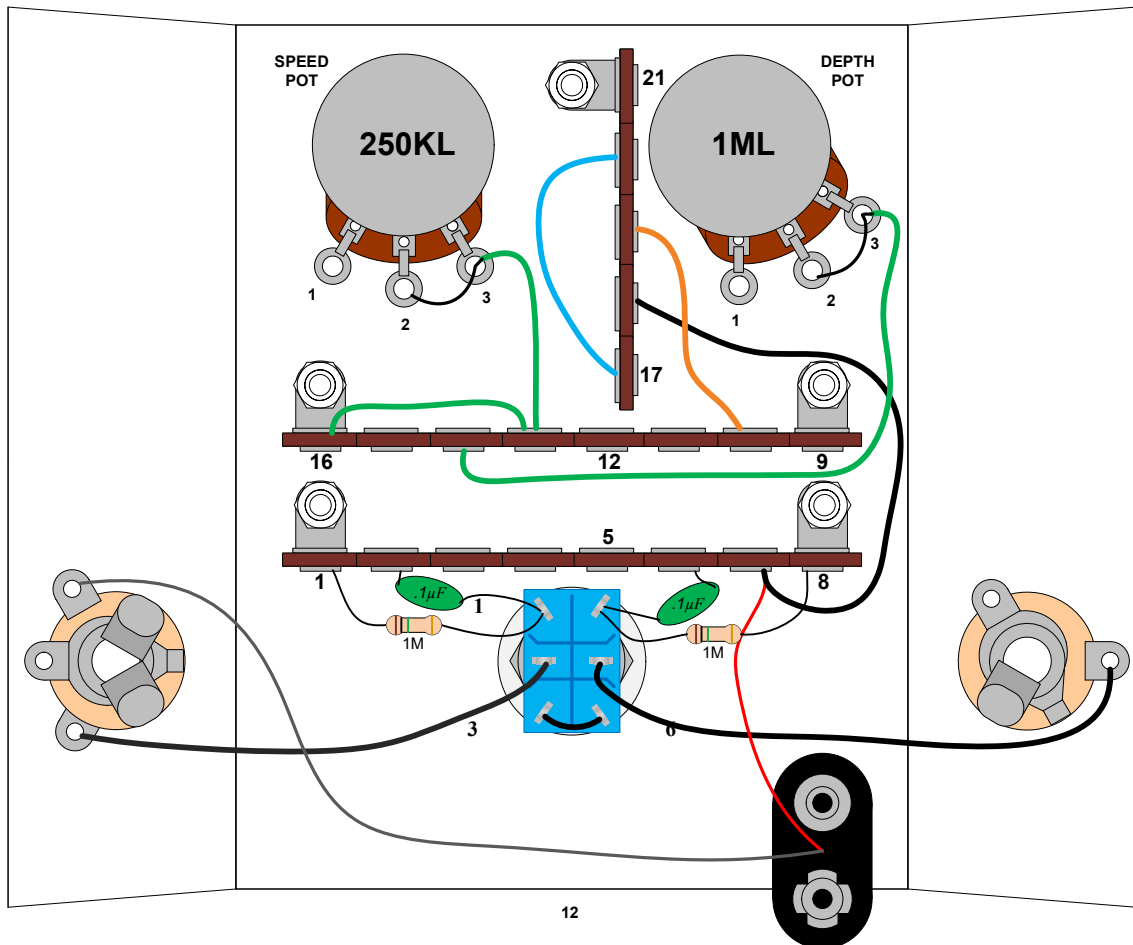

Use this troubleshooting supplement to help:

- Measure voltage test points to identify major discrepancies and locate problem areas.

Using a volt meter, connect the ground side lead of the meter to any ground point on the pedal. One ground point would be the output jack's ground lug. The other volt meter lead will be used to measure voltage at the test points listed and shown in the drawings on the next pages.

(Keep in mind that the voltage measurements will vary slightly from kit to kit. The voltages you measure should be in the same ballpark, but do not expect to get the exact same value.)

You must plug a guitar cable into the input jack when taking the voltage measurements because the input jack is set up to disconnect power from the circuit when unplugged.

***Oscillation causes the voltage measurement at test points 5 and 9 to be unstable, but they average the listed voltage with "speed" and "intensity" controls at their max (full clock-wise) settings.**

Test Point	Location Description	DC Voltage Measurement
A	Q1 Emitter	0.77 VDC
B	Q1 Base	1.37 VDC
C	Q1 Collector	1.58 VDC
D	Q2 Emitter	0.0 VDC
E*	Q2 Base	-0.25 VDC*
F	Q2 Collector	0.0 VDC
G	Q3 Emitter	0.0 VDC
H	Q3 Base	0.56 VDC
I*	Q3 Collector	1 VDC*
J	9 Volt Power Supply	9.25 VDC

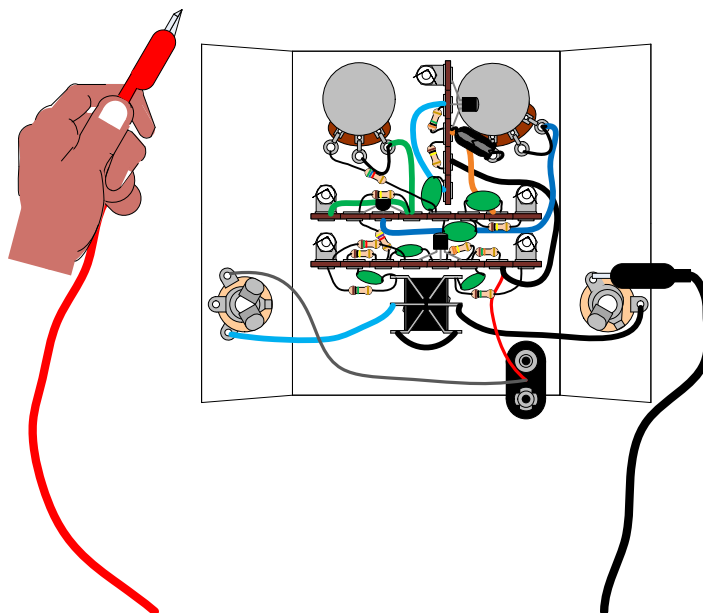

***Oscillation causes the voltage measurement to be unstable, but average the listed voltage with "speed" and "depth" controls at their max (full clock-wise) settings.**

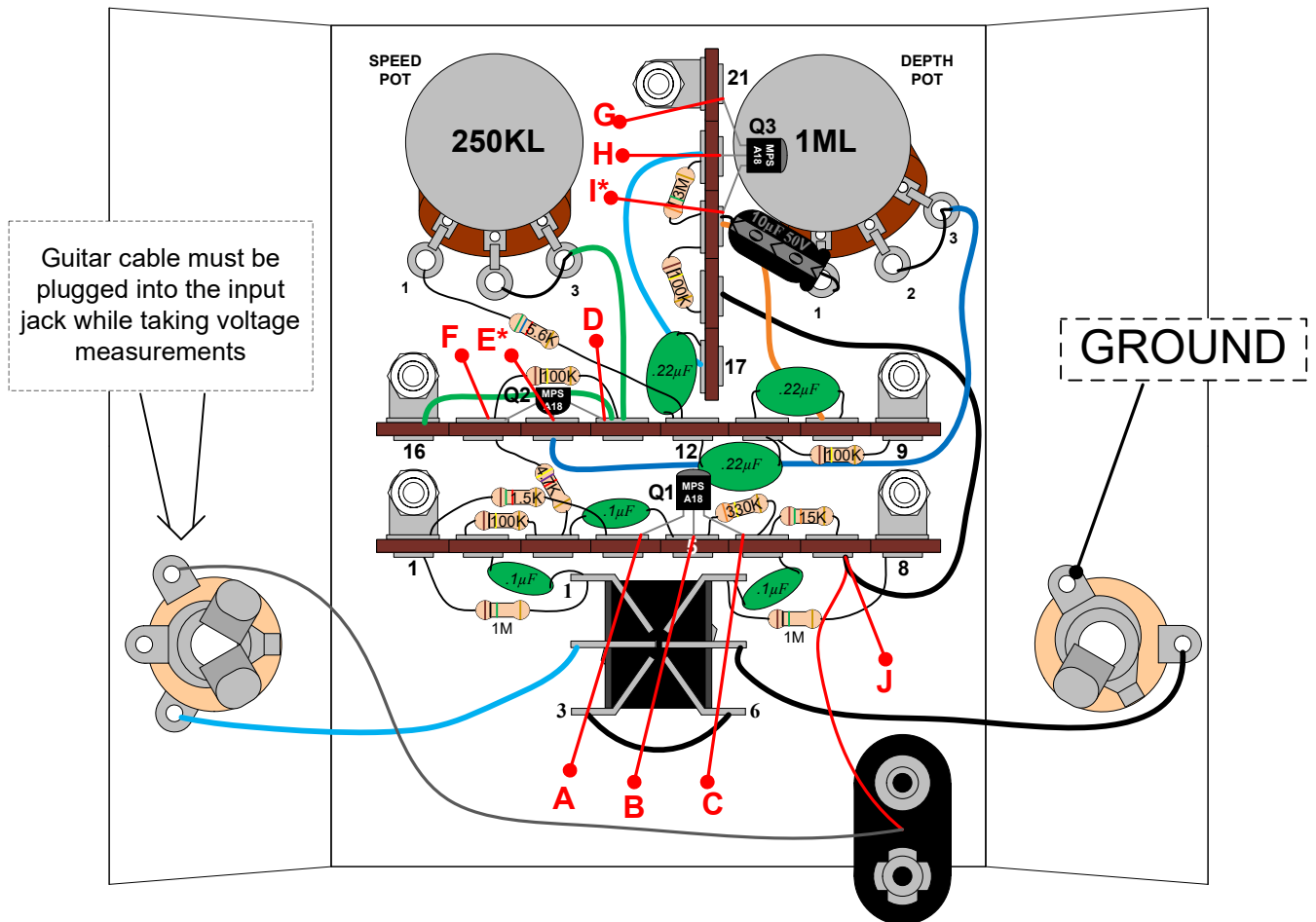

DC Voltage Test Points

AC Voltage Test Points

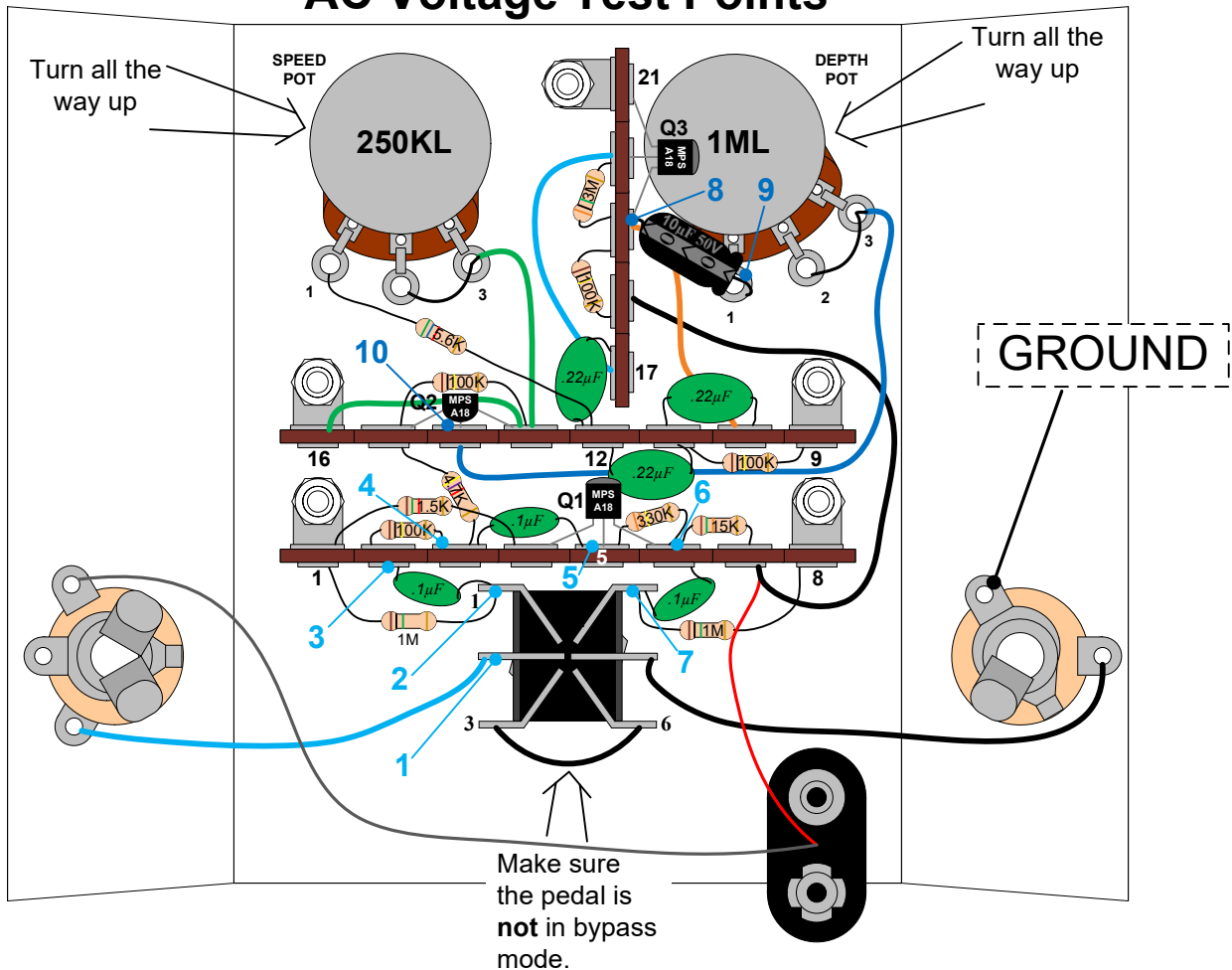

AC Test Points 1 - 7 (Signal Path)

Connect your guitar to the input jack and take AC voltage measurements at each test point with both controls turned all the way up. At each test point the AC voltage should increase dramatically each time you strum the guitar. (No strum = 0.0 VAC, Hard strum = anywhere from 10 mV to 2 V).

AC Test Points 8 - 10 (Oscillator Output)

These test points are isolated from the signal path and your guitar playing should not have an effect on the voltage readings here. At a maximum speed setting, you should have a constant waveform with a frequency of about 9.25 Hz.

All measurements taken with both speed and depth at their maximum settings

Letters (A - J) = DC Voltage measurements
 Numbers (1 - 7) = AC Voltage measurements in the signal path
 Numbers (8 - 10) = AC Voltage measurements from the oscillator

Numbers (1-7) VAC signal was produced by strumming an open E7 chord on a Fender Strat with single-coil neck pickup.

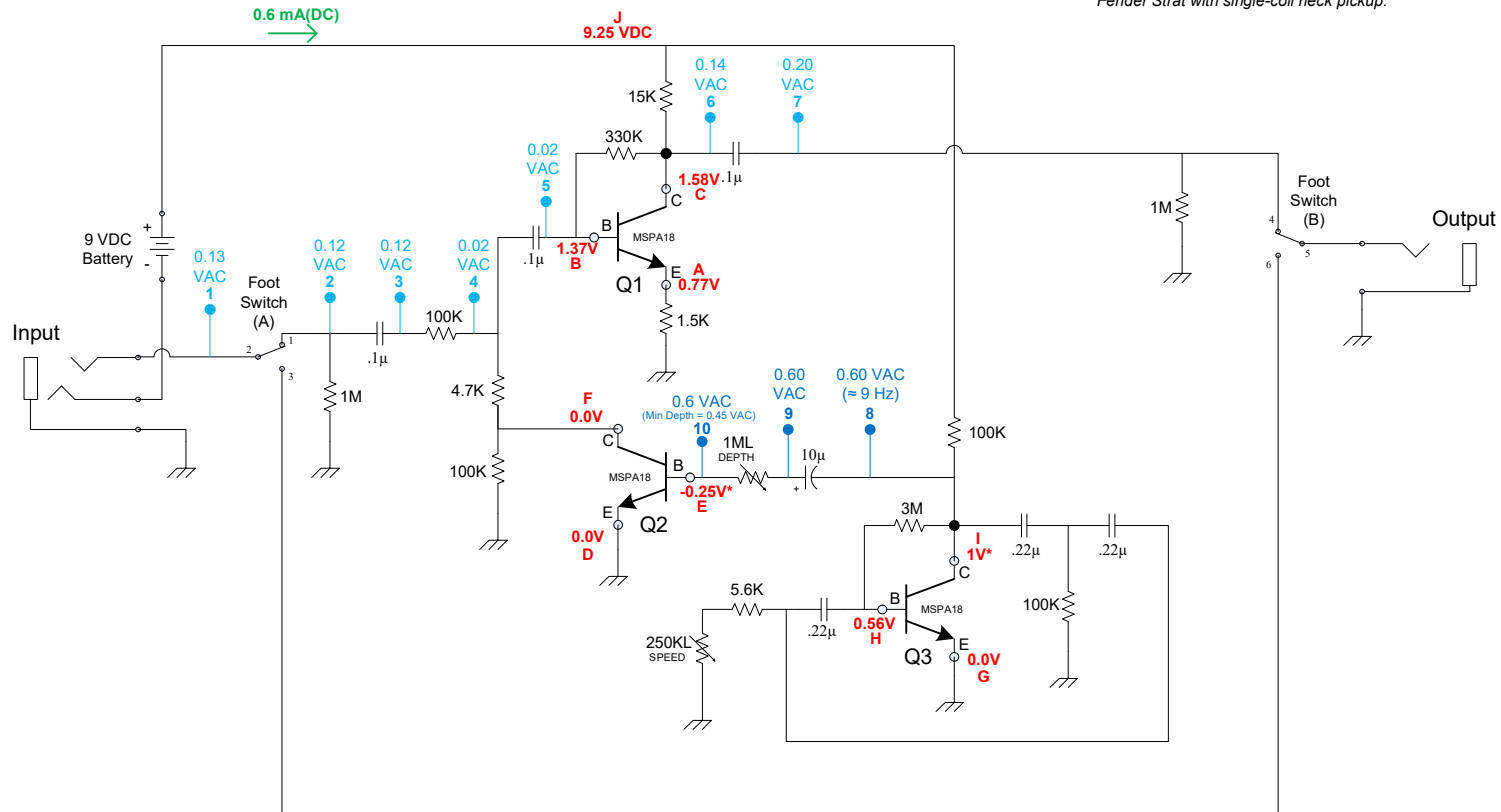

*Oscillation causes the voltage measurement to be unstable, but average the listed voltage with "speed" and "depth" controls at their max (full clock-wise) settings.

DPDT Foot Switch

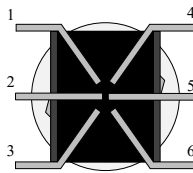

MPSA18 NPN BJT

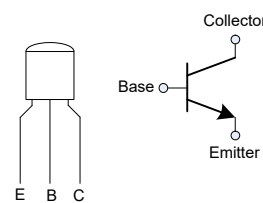

www.modkitsdiy.com
 Copyright © 2014 by modkitsdiy.com

"The Trill" (K-960) Schematic

APPLYING THE STICKER TO MOD PEDAL ENCLOSURES

1.

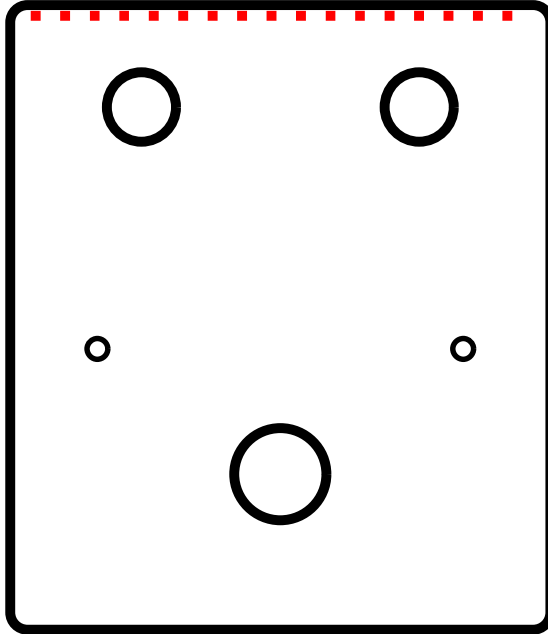

- Locate the top of the pedal as well as the top of the sticker. Page one of the instructions for your kit will have an image of the pedal that can be used for reference.

2.

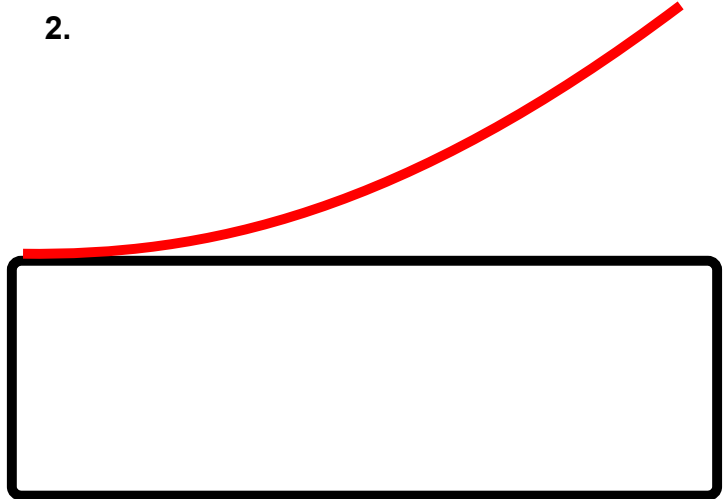

- Peel the backing from the sticker. Carefully line up the top edge of the sticker with the top of the pedal. Press down to apply the sticker only to the edge. Run a finger across the edge to push any air out from beneath the sticker. Continue this motion as you work your way down the pedal until the sticker is fully attached.

3.

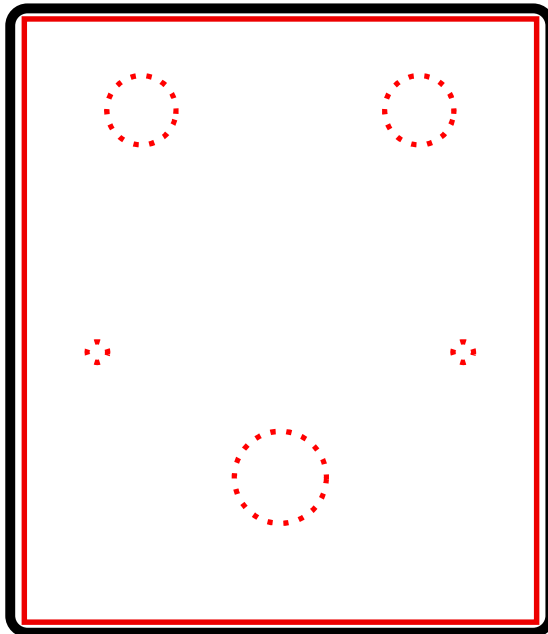

- Locate the holes beneath the sticker and depress them using a fingertip. Be sure that the area of the sticker surrounding the holes is fully adhered to the surface.

4.

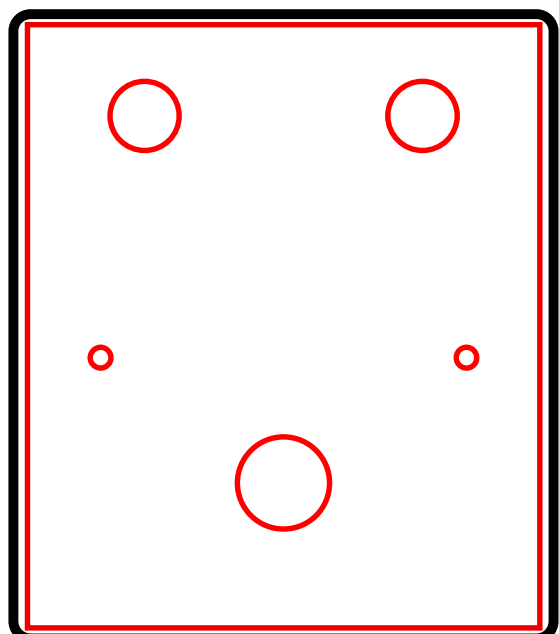

- With an Xacto knife or similar tool, carefully pierce the sticker in the center of each hole. Carefully work the knife from the center of the hole to the edge and begin cutting fully around the edge until the sticker has been fully cleared from the hole.