

THE THUNDERDRIVE DELUXE (K-955)

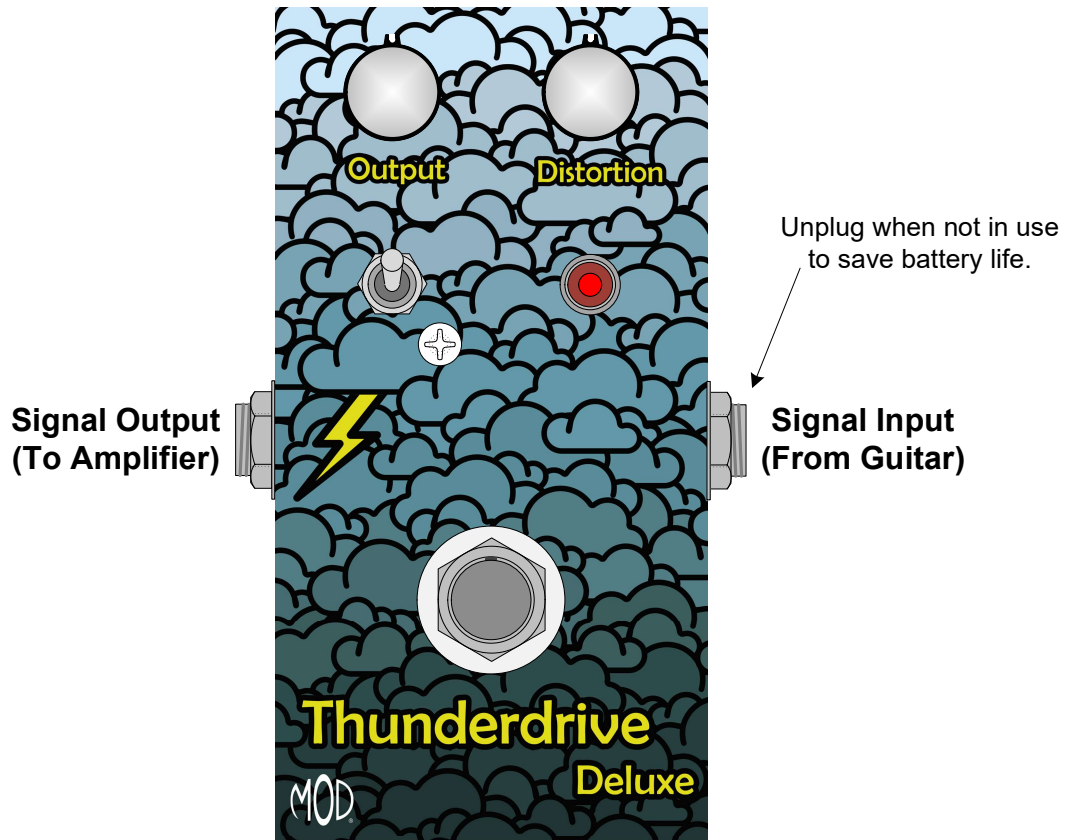

Use these instructions to learn:

- How to build an effects pedal for overdrive.

The Thunderdrive is an overdrive pedal kit that will provide a strong clean signal boost in the early gain settings and smooth distortion at maximum gain settings. Adjusting output and distortion controls provides a wide variety of tones in spite of its simple construction. It is capable of overdriving the preamp section of your guitar amp or adding its own layer of distortion at lower volume. The Deluxe version is equipped with an LED and “Turbo” switch.

The turbo switch allows you to remove the standard output clipping diodes from the circuit for a stronger signal with slightly reduced distortion. It is most effective at high distortion settings, but has little impact with the distortion control set to a minimum.

Warning: This circuit was designed for use with a 9 VDC power supply only.



TABLE OF CONTENTS

TOOL LIST	2
PARTS LIST DRAWINGS.....	3, 4
SOLDERING TIPS	5
STEP BY STEP ASSEMBLY INSTRUCTIONS	6
Section 1 – Mount LED, ¼” Jacks and Terminal Strip Components	6
Section 2 – Mount Potentiometers, Footswitch and Toggle Switch	7
Section 3 – Mount and Connect Remaining Components	7
Section 4 – Wire Remaining Connections	8

ASSEMBLY DRAWINGS (4 Drawings)

9, 10
These are the last 2 pages. They should be separated and used as a reference to help assemble the kit correctly.

TOOL LIST

- Wire Strippers
- Needle Nose Pliers
- Cutting Pliers
- Desoldering Pump
- Solder (60/40 rosin core)
- Soldering Station
- Phillips Head Screwdrivers
- Slotted tip screwdrivers (3 mm tip)
- Channellock Pliers (or similar type)
- Ruler
- Hobby Vise (or other means to secure box while working)
- Exacto knife or similar cutting tool

PARTS LIST 1

Stranded Wire (22 AWG) - Red
K-PUL1569 (3 FT)

Enclosure
P-H1590BCE-BK (1)

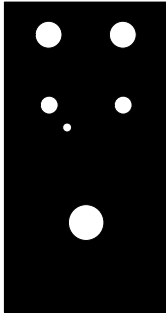

Knob
P-K384 (2)



Battery Clip
S-H155 (1)

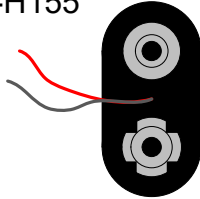

1/4" Mono Jack (Output Jack)
W-SC-11-T (1)

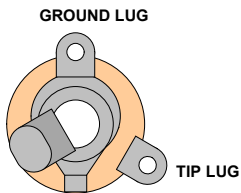

1/4" Stereo Jack (Input Jack)
W-SC-12B (1)

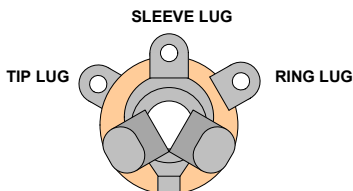

3PDT Foot Switch
P-H501 (1)

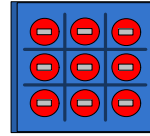

250kΩ Potentiometer (Audio Taper)
R-VBM-250KA-SS (2)

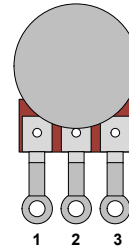

Terminal Strip with 5 Terminals
P-0501H01 (1)

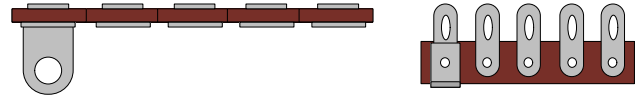

#4 Screw (3/8" long)
S-HS440-38 (1)



#4 Nut
S-HHN440 (1)



#4 Lock Washer
S-HLW4 (1)



3/8" Lock Washer
S-HLW38 (2)

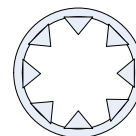

PARTS LIST 2

NPN BJT (2N5088)

P-Q2N5088

(1)

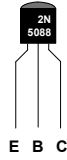

820Ω Resistor 1/2 W

R-A820

(1)

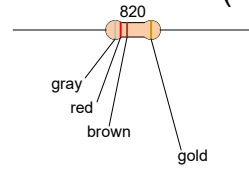

1N4148 HIGH SPEED SOLID STATE DIODE

P-Q971

(2)



4.7kΩ Resistor 1/2 W

R-A4D7K

(1)

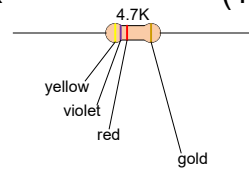

0.1μF Capacitor 50V

C-PFD1-50-R

(2)

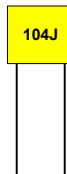

2MΩ Resistor 1/2 W

R-A2M

(1)

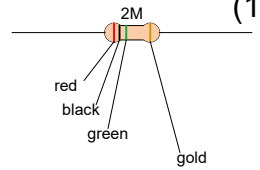

SPDT Toggle Switch

P-H540

(1)

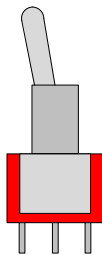

Thunderdrive Deluxe Sticker

(1)

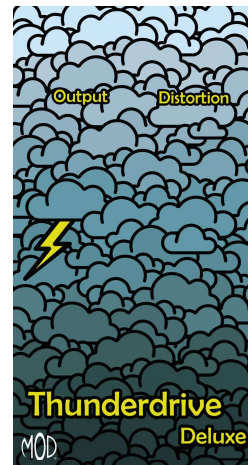

Light Emitting Diode

P-L400

(1)

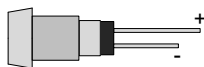

SOLDERING TIPS

It is important to make a good solder joint at each connection point. A cold solder joint is a connection that may look connected but is actually disconnected or intermittently connected. (A cold solder joint can keep your project from working.)

Follow these tips to make a good solder joint. *Take your time with each connection and make sure that all components are connected and will remain connected if your project is bumped or shaken.*

1. Bend the component lead or wire ending and wrap it around the connection point.
 - Make sure it is not too close to a neighboring component which could cause an unintended connection.
2. Wrap the component lead so that it can hold itself to the connection point.
3. Touch the soldering iron to both the component lead and the connection point allowing both to warm up just before applying the solder to them.
4. Be sure to adequately cover both component lead and connection point with melted solder.
 - Remove the soldering iron from your work and allow the solder joint to cool. (The solder joint should be shiny and smooth after solidifying.)
 - Cut off any excess wire or component leads with cutting pliers.
 - Clean the soldering iron's tip by wiping it across the wet sponge again after making the solder joint.

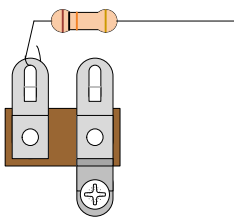

1. Bend the component lead and wrap it around the connection point.

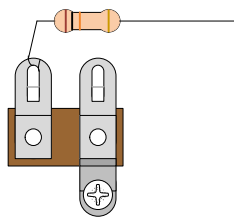

2. Wrap the component lead so that it can hold itself to the connection point.

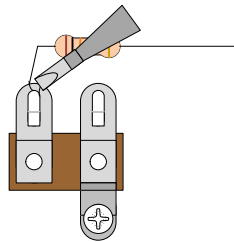

3. Heat up both component lead and connection point with the soldering iron.

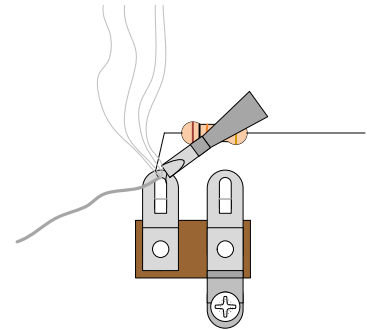

4. Apply solder to both component lead and connection point.

De-Soldering Tip

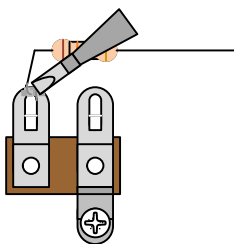

1. Heat up old solder joint with the soldering iron.

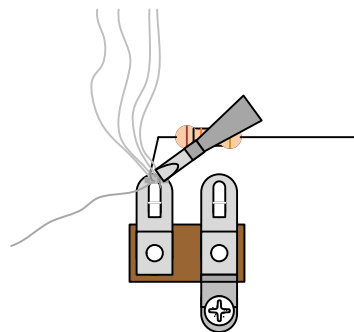

2. Apply fresh solder to mix in with old solder joint

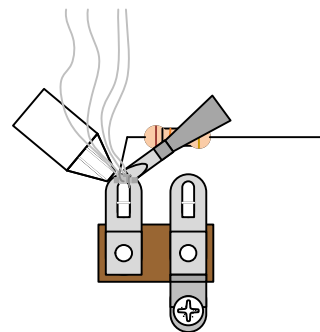

3. Use a de-soldering tool to remove the old solder joint while it is heated.

SECTION 1 – Mount LED, 1/4" Jacks and Terminal Strip Components

Please refer to **DRAWING 1** and **DRAWING 2**.

Orient the box with 1/2" hole nearest you.

Apply the sticker to the top of the box then use a blade to cut out the holes.

1) Mount the LED in the 1/4" hole below the distortion pot's mounting hole. The lock washer goes over the threaded portion prior to insertion through the top of the enclosure. Align the LED leads so that the anode (long lead) is closer to where the terminal strip will be as shown in Drawing 2.

The Anode (+) side of the LED is indicated by a slightly longer lead and/or a positive sign.

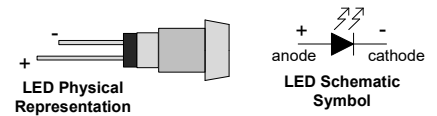

2) Mount input jack in 3/8" hole on left side of box with hardware provided.

Washer goes under nut on outside of box. Make sure center "ground" lug of input jack is facing up. Correct positioning of jack will make soldering connections much easier. When positioned correctly, tighten nut.

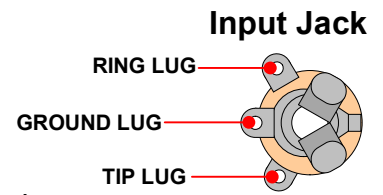

3) Mount output jack in 3/8" hole on right side of box with hardware provided.

Washer goes under nut on outside of box. Make sure the "tip" lug is on top (towards the enclosure opening) before tightening nut.

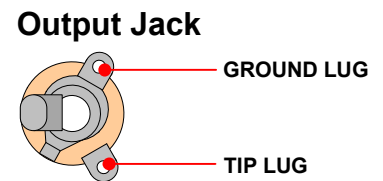

4) Mount the terminal strip to the 1/8" hole as shown in drawing 2.

We will refer to terminal numbers from "1" to "5" as illustrated.

Unless noted otherwise, connect and solder all of the following to their respective connection points as stated. (Make sure none of the component leads are so close together that they could lead to an unintended connection). *Be careful not to overheat the solid state devices (diodes and transistor) when soldering.*

5) Strip and tin a 1 1/2" piece of wire and connect terminal #1 to #3.

You might want to connect to the lower terminal holes to leave room for other components.

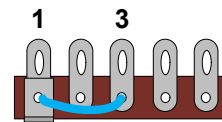

6) Mount the 2N5088 transistor to terminals 3, 4 and 5. **Do not solder.**

Terminals #3: Emitter

Terminals #4: Base

Terminals #5: Collector

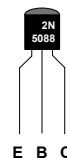

7) Mount the 4.7K resistor to terminals 2 and 5. **Do not solder.**

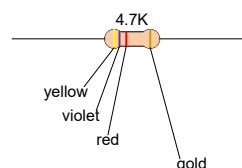

8) Mount the 2M resistor to terminals 4 and 5. **Do not solder.**

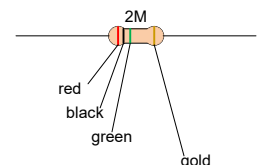

SECTION 2 – Mount Potentiometers, Footswitch and Toggle Switch

Please refer to **DRAWING 3 & DRAWING 4**.

1) Mount the two 250K potentiometers in the 3/8" holes at the top of the enclosure using hardware provided.

Remove nut and flat washer from potentiometers and place large lock washers (S-HLW38) over shaft of each pot before inserting them through their mounting holes. Fasten nut over flat washer and tighten.

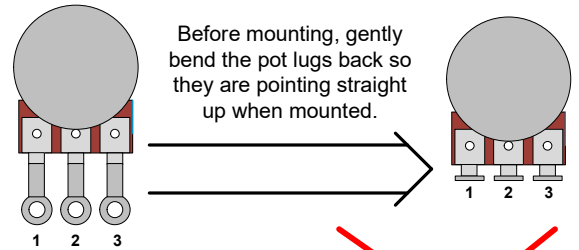

2) Mount the 3PDT footswitch in the 1/2" hole with its solder lugs oriented as in the drawing.

(The top hex nut and large plastic washer should be fastened on the outside of the box).

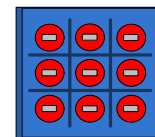

Correct Orientation

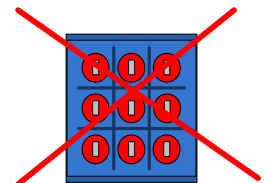

Incorrect Orientation

3) Mount the SPDT toggle switch in the 1/4" hole below the output pot. The lock washer goes over the shaft before inserting through the chassis hole. The flat washer goes on the top side of the enclosure, under the nut. Align the switch as shown in the drawing and tighten the nut.

4) Connect the 820 Ω resistor from terminal #2 to the anode (+) lead of the LED.

Clip the anode lead of the LED and resistor to a reasonable length and connect them by bending and crimping the leads around each other. Solder them once they are tightly connected to each other.

5) Take the two 1N4148 diodes and place their bodies side by side with the reverse polarity of one another (see below) and twist their leads together as shown.

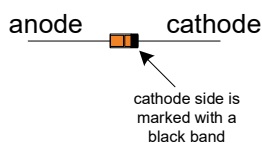

“Reverse polarity of one another” means to connect the cathode of each diode to the anode of the other diode.

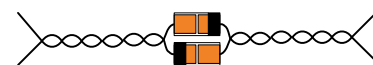

Connect one end of these two 1N4148 diodes to terminal #1 of the terminal strip and the other end to the middle lug (pole) of the toggle switch. Make sure the leads of these diodes will not accidentally touch any of the other lugs on the toggle switch.

SECTION 3 – Mount and Connect Remaining Components

Please refer to **DRAWING 4**.

1) Connect one of the 0.1 μ F capacitors with one lead at terminal #5 of the terminal strip and the other lead to both output pot lug “1” and the top lug of the toggle switch (as shown). **Solder all connections at output pot lug “1”, terminal #5 and toggle switch now.**

2) Connect the other 0.1 μ F capacitor to terminal #4 and to both lugs “2” and “3” of the distortion pot. **Solder all connections at terminals #3, #4 and distortion pot lugs “2” and “3” now.**

3) Locate the battery clip. Cut 1 ½" length off the ends of each lead and discard (or save for other projects). Connect the black lead to the "ring" lug of the input jack. Connect the red lead to terminal #2 of the terminal strip. Solder these connections now.

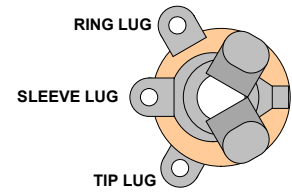

SECTION 4 – Wire Remaining Connections

- 1) Strip and tin a 1 ½" piece of wire connect footswitch lugs "3" and "9".
- 2) Strip and tin a 1" piece of wire and connect the input jack "tip" lug to the footswitch lug "2".
- 3) Strip and tin a 3 ½" piece of wire and connect footswitch lug "1" to distortion pot lug "1".

4) Strip and tin a 1 ¾" piece of wire and connect the output jack "ground" lug to output pot lug "3".

5) Strip and tin a 1 ¼" piece of wire and connect the output jack "tip" lug to footswitch lug "8".

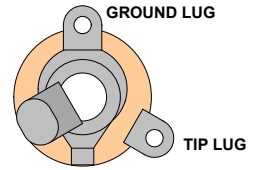

6) Strip and tin a 2 ½" piece of wire and connect the output pot lug "2" to footswitch lug "7".

7) Strip and tin a 2 ½" piece of wire and connect the cathode lead of the LED to footswitch lug "4". Solder both of these connections now.

8) Strip and tin a 1 ½" piece of wire and connect the footswitch lug "5" to the ground lug of the input jack. Solder these connections now.

Finish it off by double-checking all of your connections, connect and insert a 9V battery, screw the lid on and fasten the knobs to both pot shafts.

DRAWING 1

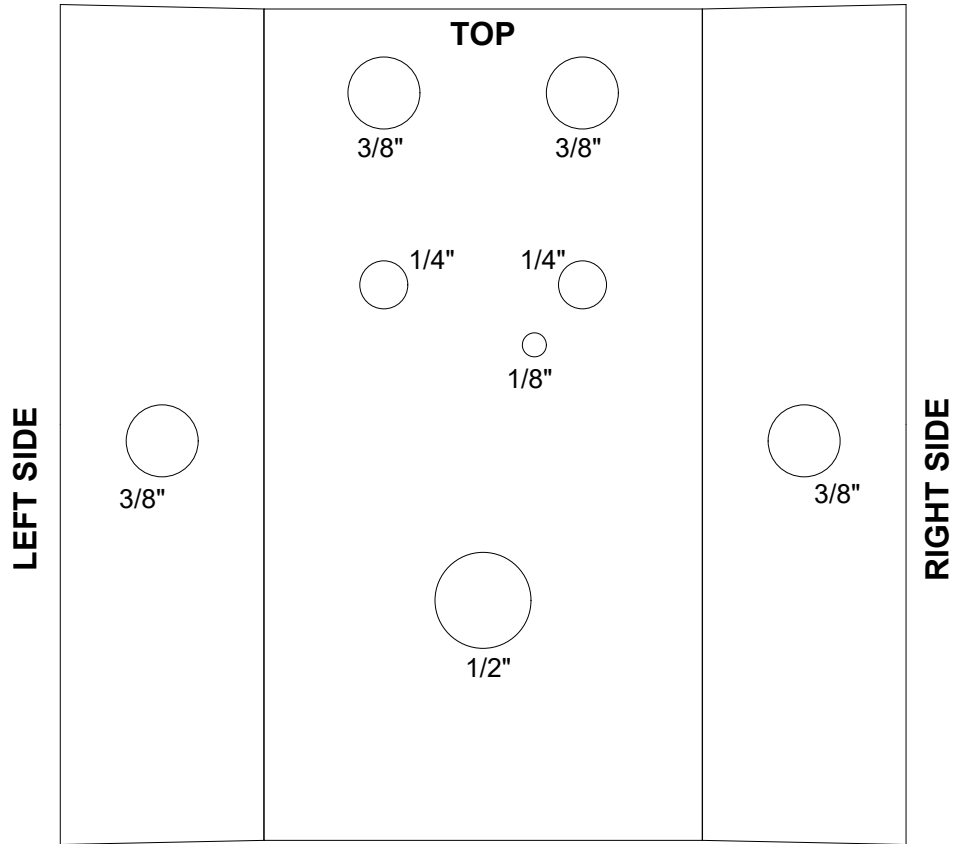

DRAWING 2

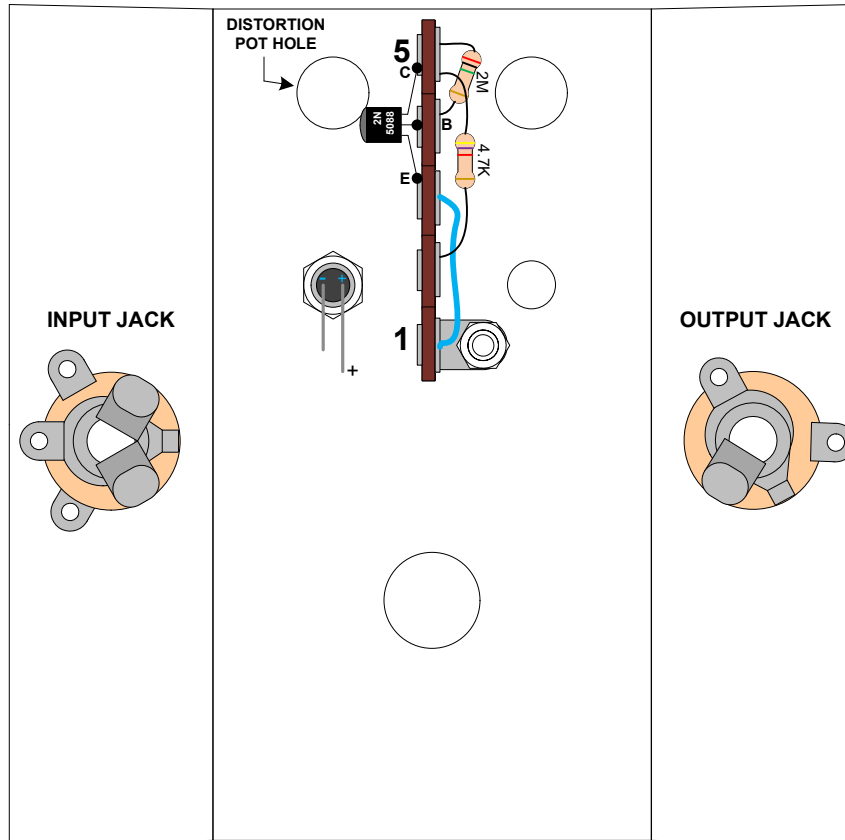

DRAWING 3

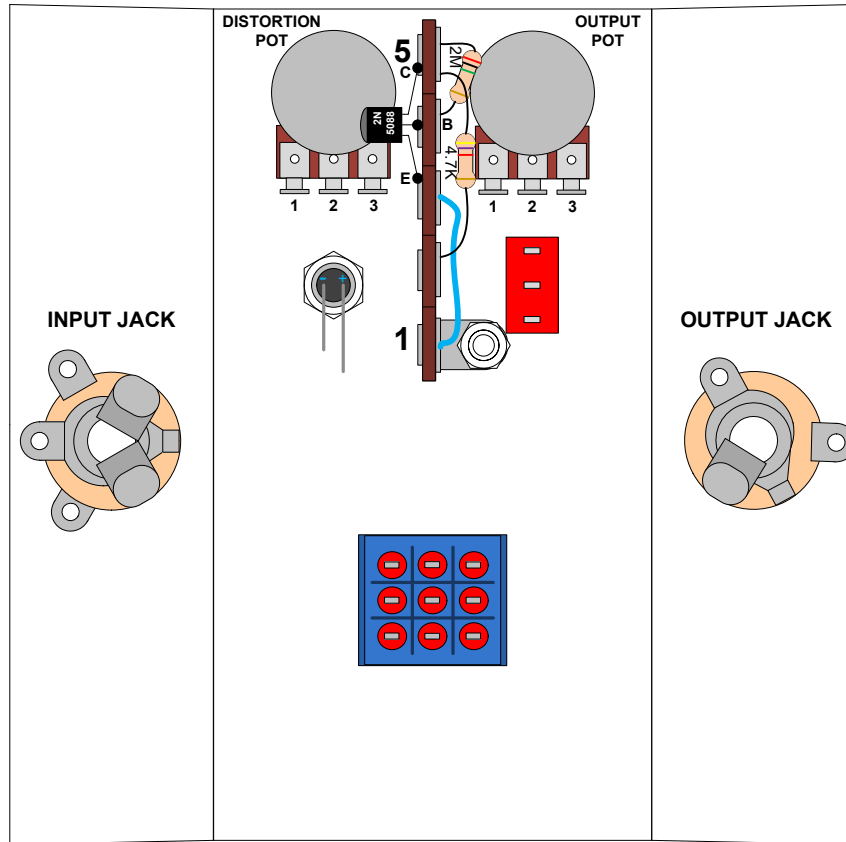

DRAWING 4

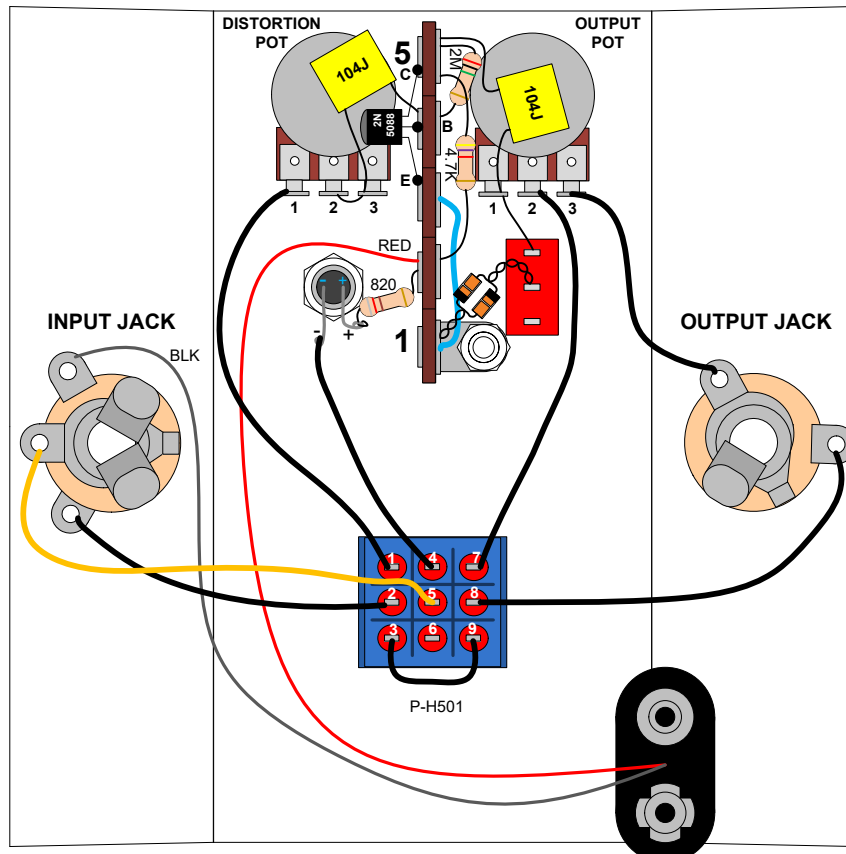

Use this troubleshooting supplement to help:

- Measure DC voltage test points to identify major discrepancies and locate problem areas.

(Keep in mind that the voltage measurements will vary slightly from kit to kit. The voltages you measure should be in the same ballpark, but do not expect to get the exact same value.)

Test Point	Location Description	Voltage Measurement	Your Unit's Voltages
1	Transistor Collector	3.1 VDC	
2	Transistor Base	0.6 VDC	
3	Transistor Emitter	0.0 VDC	
4	Power	8.9 VDC	
5	LED Anode (+)	2 VDC	

You must plug a guitar cable into the input jack when taking the voltage measurements because the input jack is set up to disconnect power from the circuit when unplugged.

Using a volt meter, connect the ground side lead of the meter to any ground point on the pedal. One convenient ground point would be the output jack's ground lug. The other volt meter lead will be used to measure DC voltage at the test points listed above and shown in the drawing on the next page.

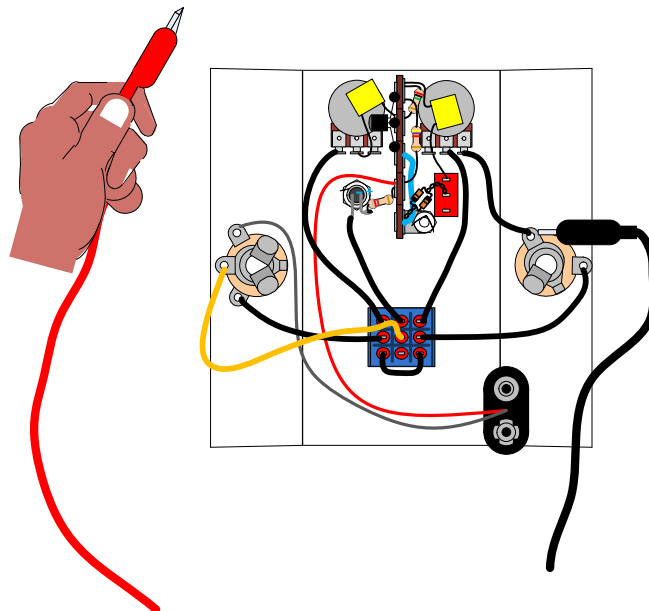

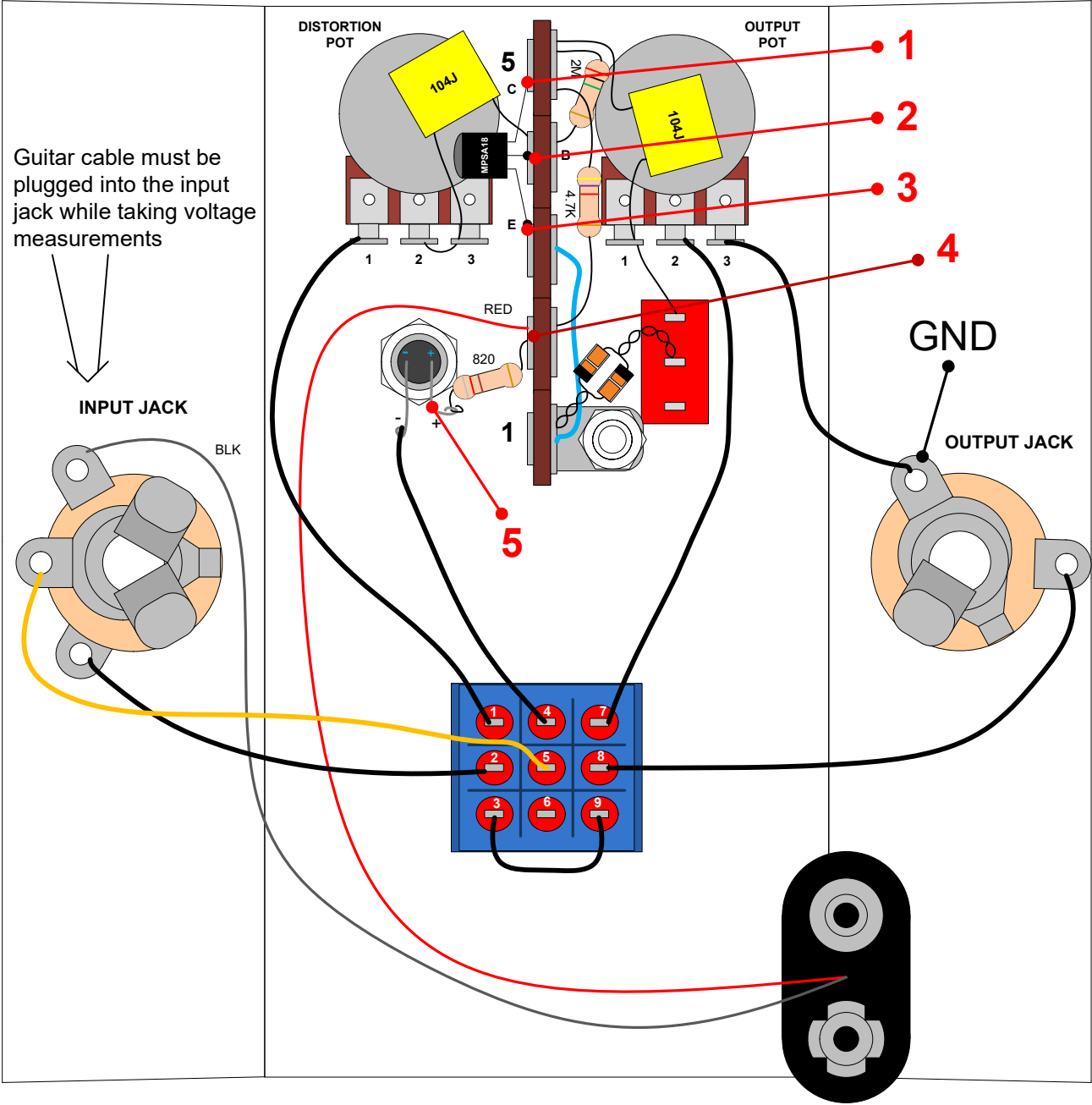

DC Voltage Test Points

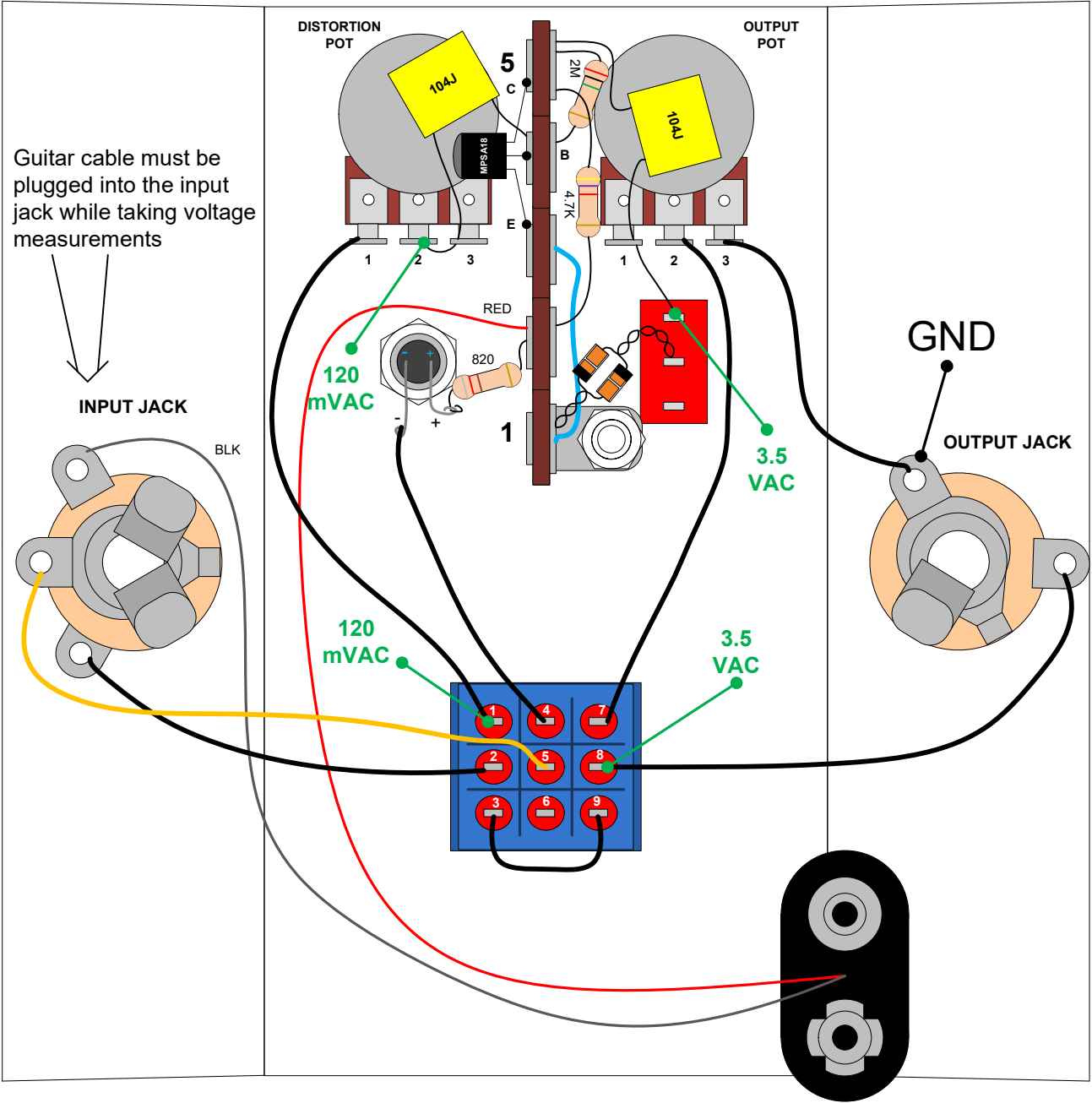

**AC Voltage Test Points
(Distortion set to Max)**

Continuity Tests

With your meter set to check continuity, check the **footswitch terminal continuity** to make sure it is switching correctly.

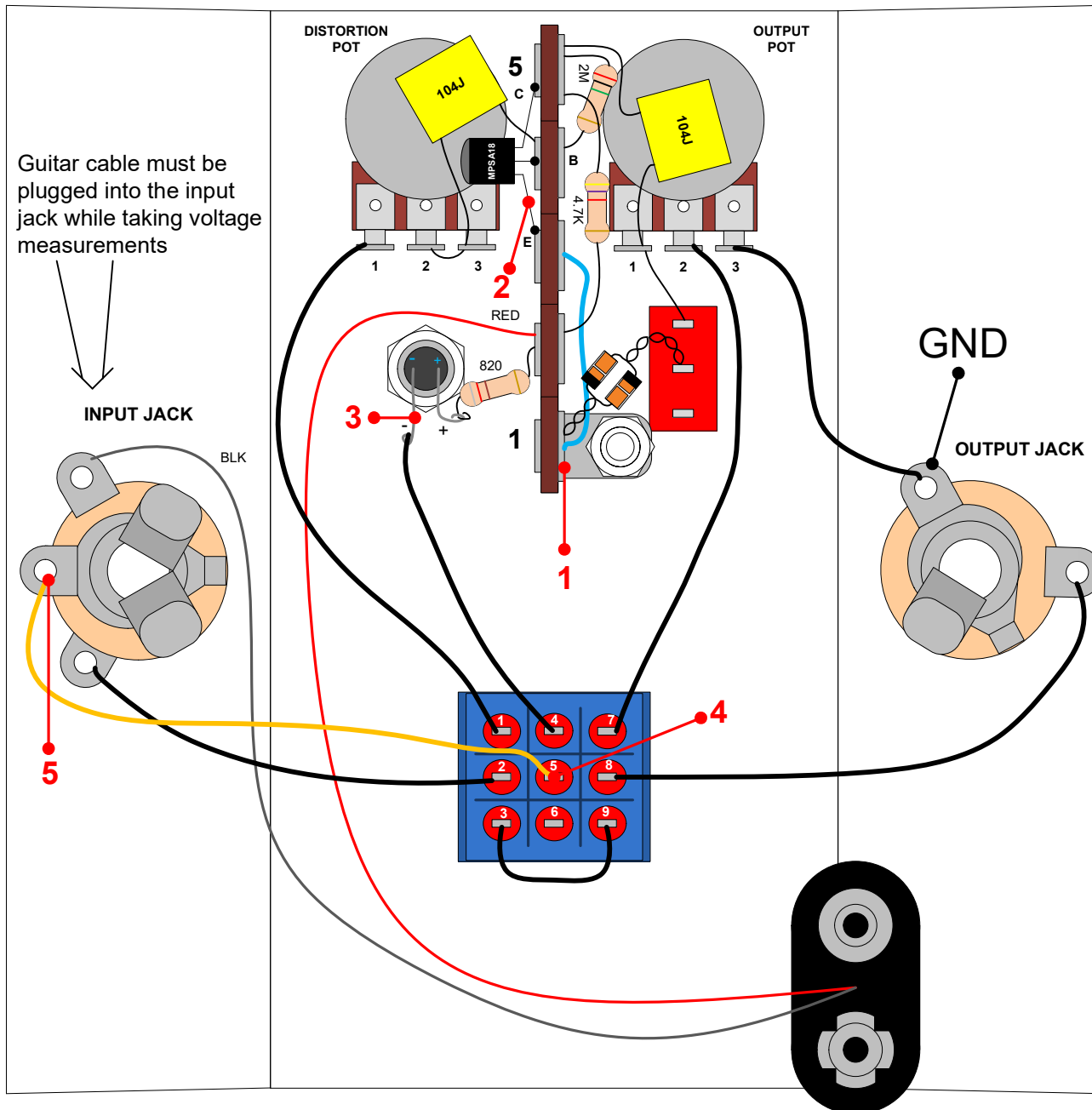

3PDT Foot Switch

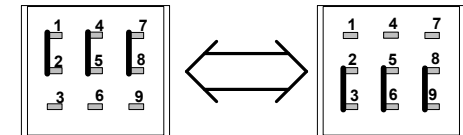

Switching function of the 3PDT switch. The solid line illustrates an internal connection between terminals.

The effect is **on** when there is continuity from terminals: 1 to 2, 4 to 5 and 7 to 8

The effect is **bypassed** when there is continuity from terminals: 2 to 3, 5 to 6 and 8 to 9

With the footswitch set to effect-on terminal continuity (as shown above), check for **ground continuity** to make sure you have proper ground connections between the output jack's ground terminal (GND) and the following test points.

1. Terminal Strip Terminal #1 and GND
2. Transistor Emitter lead and GND
3. LED Cathode (-) lead and GND
4. Footswitch Terminal #5 and GND
5. Input Jack ground lug and GND

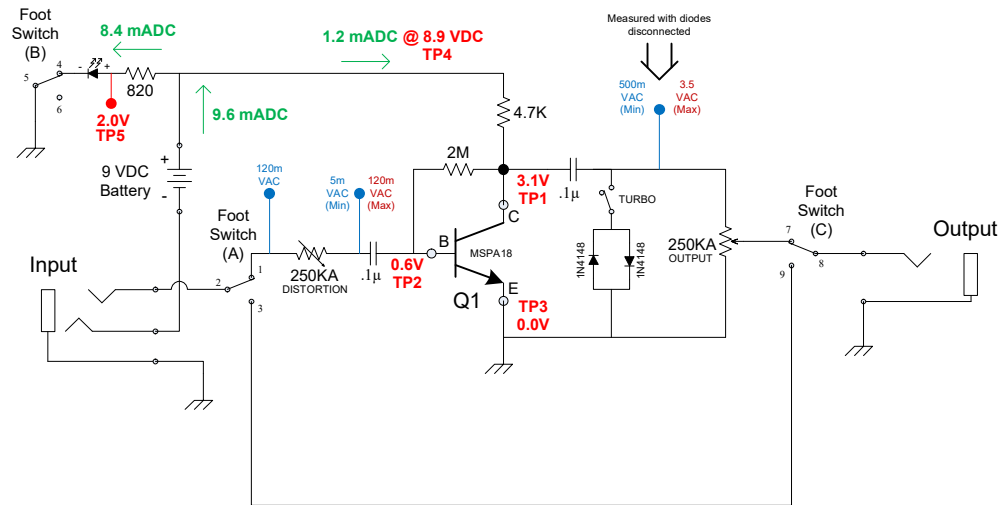

3PDT Foot Switch

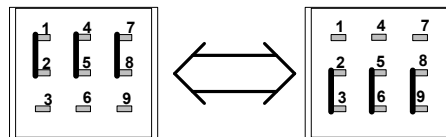

Switching function of the 3PDT switch. The solid line illustrates an internal connection between terminals.

MPSA18
NPN BJT

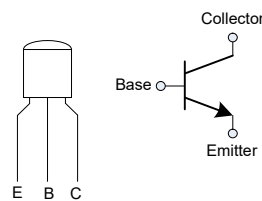

MOD™

www.modkitsdiy.com
Copyright © 2011 by modkitsdiy.com

"The Thunderdrive Deluxe" (K-955)
Schematic

APPLYING THE STICKER TO MOD PEDAL ENCLOSURES

1.

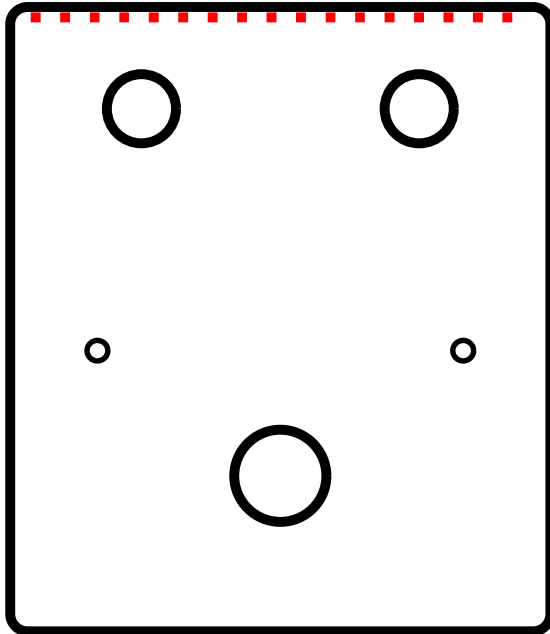

- Locate the top of the pedal as well as the top of the sticker. Page one of the instructions for your kit will have an image of the pedal that can be used for reference.

2.

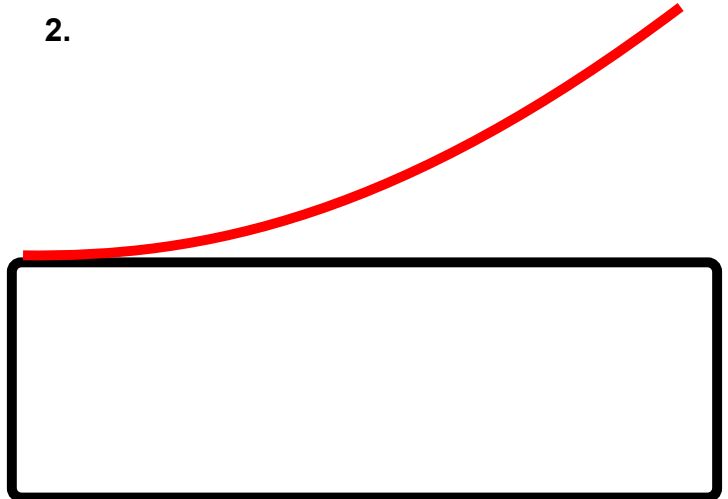

- Peel the backing from the sticker. Carefully line up the top edge of the sticker with the top of the pedal. Press down to apply the sticker only to the edge. Run a finger across the edge to push any air out from beneath the sticker. Continue this motion as you work your way down the pedal until the sticker is fully attached.

3.

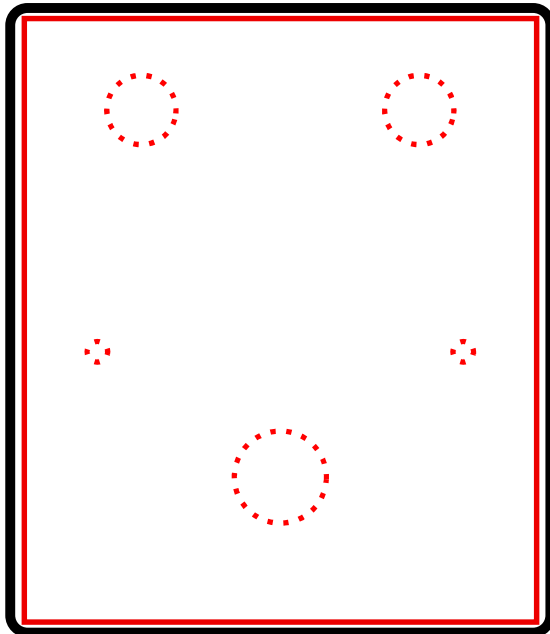

- Locate the holes beneath the sticker and depress them using a fingertip. Be sure that the area of the sticker surrounding the holes is fully adhered to the surface.

4.

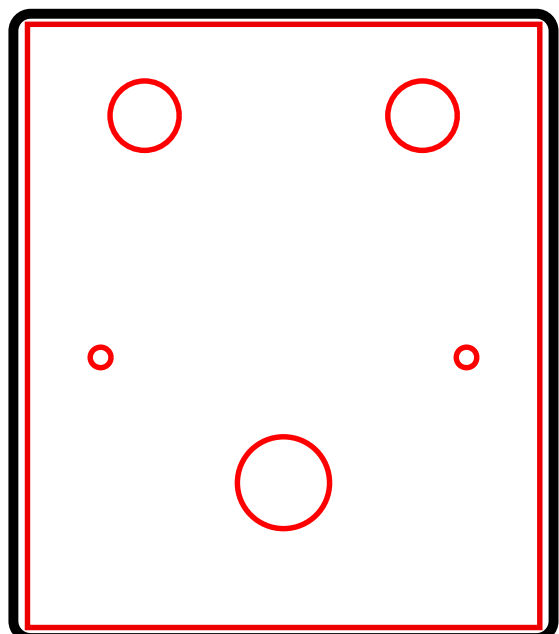

- With an Xacto knife or similar tool, carefully pierce the sticker in the center of each hole. Carefully work the knife from the center of the hole to the edge and begin cutting fully around the edge until the sticker has been fully cleared from the hole.