

K-GMOD-1 - 3 Position Telecaster Wiring Kit

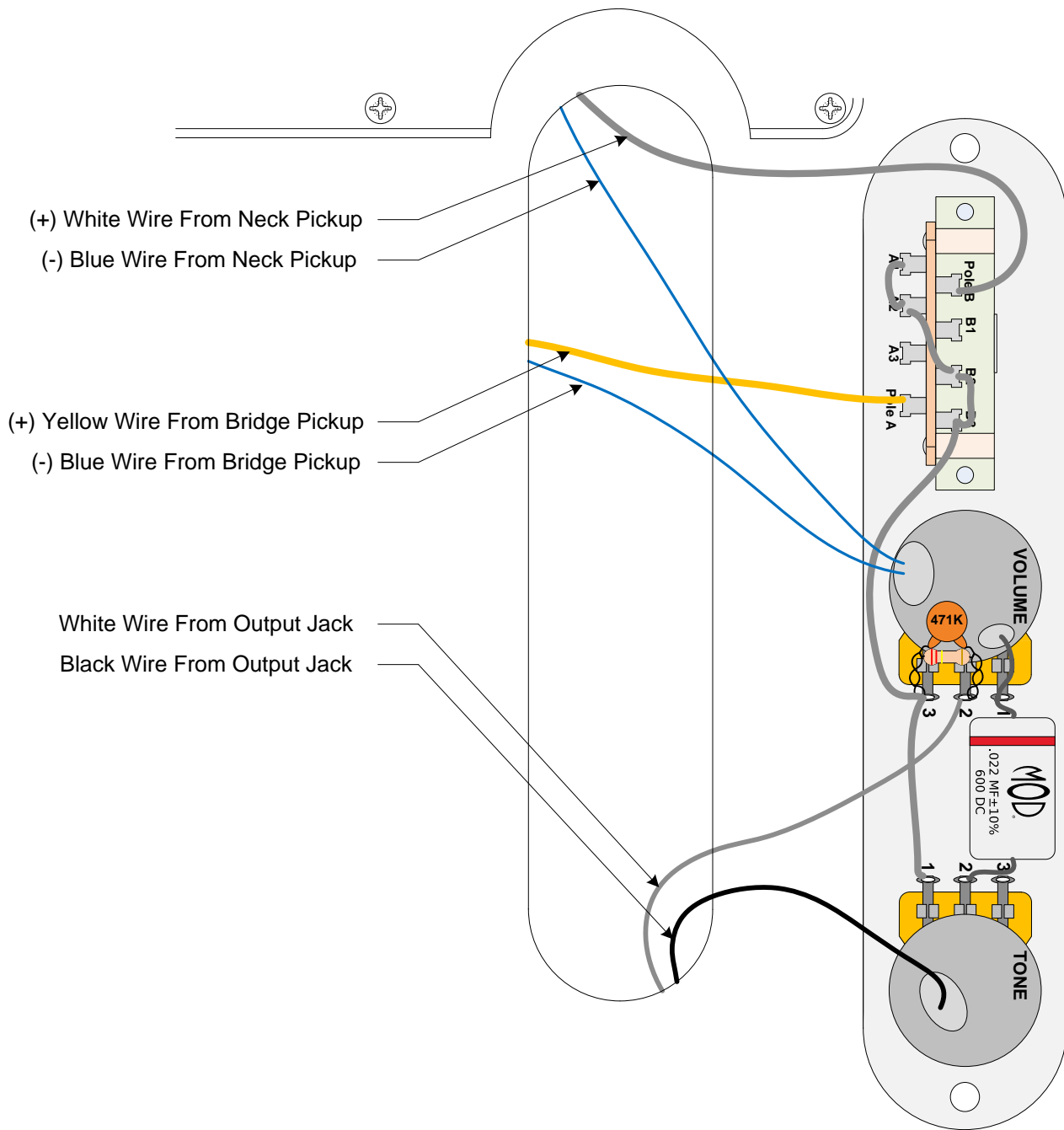

Telecaster 3-Way Vintage Series
Standard Assembly Final Wiring



Copyright © 2020 by modelectronics.com

K-GMOD-1 Wiring Diagram

K-GMOD-1 PARTS LIST

Potentiometers with Audio Taper

R-VC250KA-M (2)

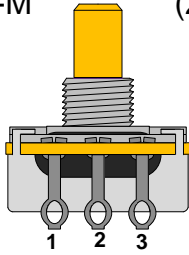

Stranded Cloth Wire Pretinned - White

S-W902W (24")

Stranded Cloth Wire Pretinned - Black

S-W902B (12")

3-Way Pickup Selector Switch

P-SW64 (1)

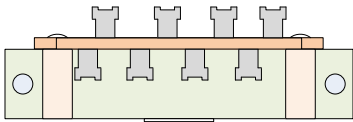

Control Plate (**Sold Separately**)

- Requires 3/8" Mounting Holes for Pots

- Example Dimensions Given Below

1/4" Mono Jack (Output Jack)

W-SC-11 (1)

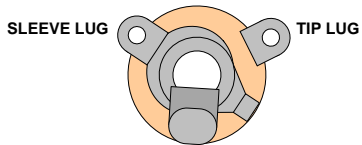

220kΩ Resistor 1/4 W

R-C220K (1)

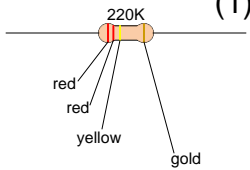

470pF Ceramic Disc Capacitor

C-CD470-500 (1)



0.022μF Mod Oil Capacitor

C-MOD022-600 (1)

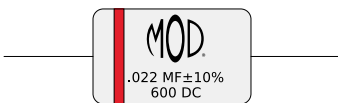

(Capacitor may appear smaller in drawings to more easily show connections)

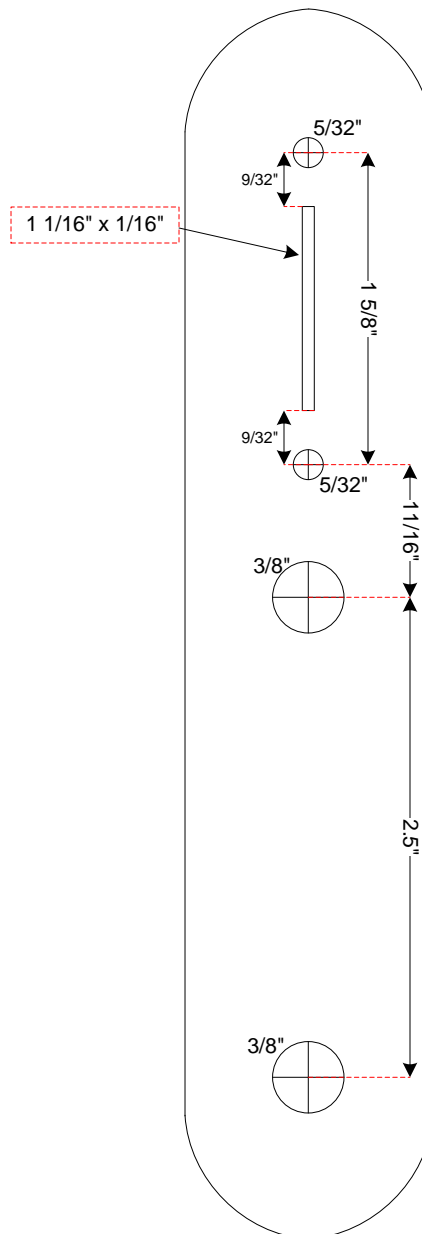

K-GMOD-1 Assembly Instructions

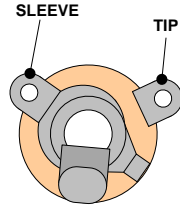
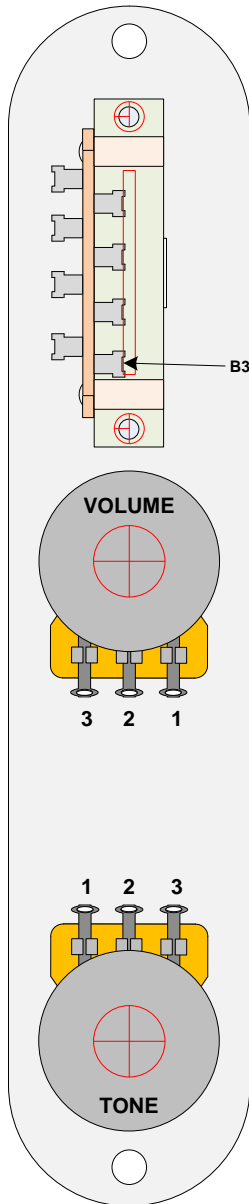

1. Mount the components to their respective mounting holes as shown.

- 2 x 250KA pots
- 1 x Pickup Selector Switch
- Keep output jack unmounted until all wiring is complete

2. Strip a 1 ½" piece of white wire and connect it from tone pot lug 1 to volume pot lug 3. **Do not solder the volume pot connection, yet.**

3. Strip a 3" piece of white wire and connect it from volume pot lug 3 to selector switch terminal "B3". **Do not solder the connections at the volume pot lug 3, yet.**

4. Wind the 220K resistor and 470pF capacitor leads together in parallel.

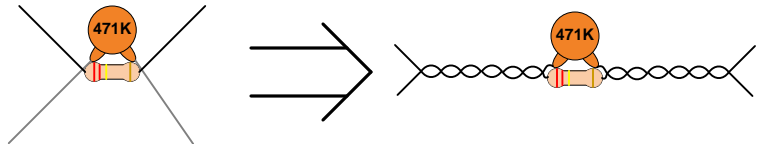

5. Connect these capacitor and resistor leads to the volume pot lugs 2 and 3 as shown (on p. 3). Solder the connection at volume pot lug 3, now. **Do not solder at volume pot lug 2, yet.**

6. Strip a 5 ½" length of black wire. Connect one end to the sleeve lug of the output jack.

7. Strip a 7" length of white wire. Connect one end to the tip lug of the output jack.

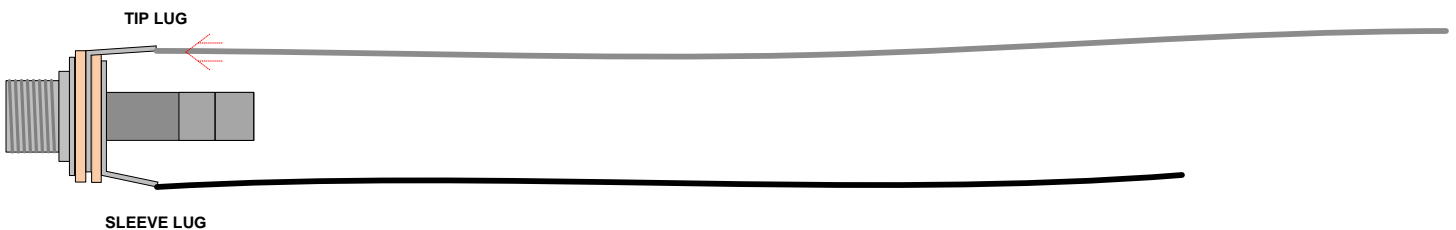

8. Connect the 5 ½" black wire to the body of the tone pot as shown.
9. Connect the 7" white wire to the volume pot lug 2.
10. Solder all connections at volume pot lug 2.
11. Connect one lead of the tone cap (.022μF) to tone pot lug 2. Connect the other lead to both volume pot lug 1 and the body of the volume pot.

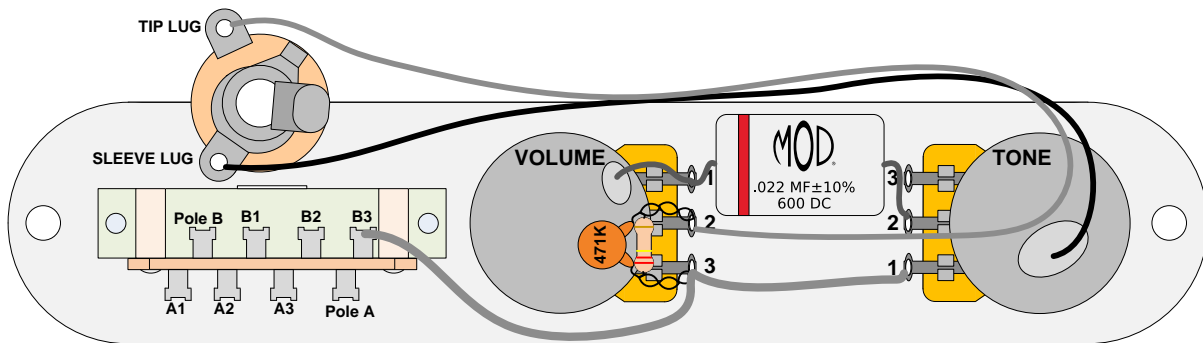

12. Strip a 2" piece of white wire. Connect it to terminals A1 and A2.
13. Strip a 2" piece of white wire. Connect it to terminals B2 and B3.
14. Strip a 3" piece of white wire. Connect it to terminals A2 and B2.
15. Solder all of the selector switch connections, now.

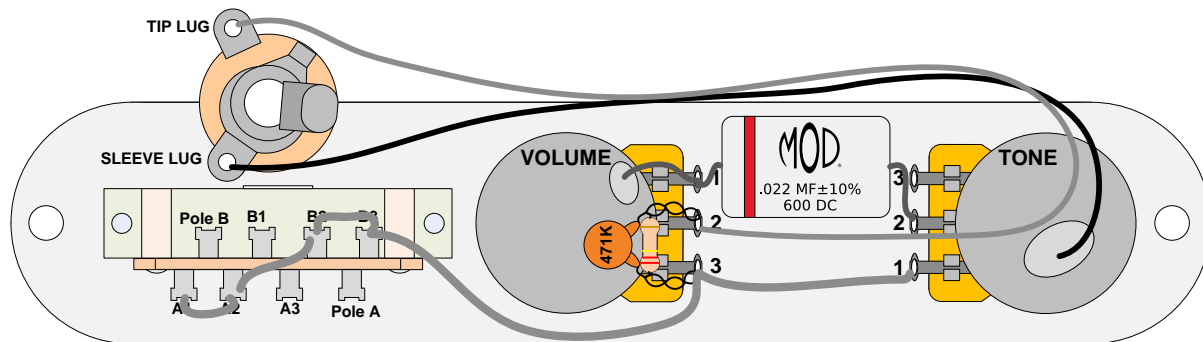
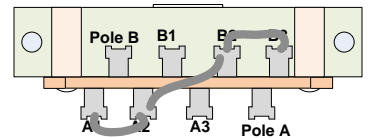

16. See final wiring drawing to complete the wiring by attaching the pickup wires. The negative wires connect to ground on the back of the volume pot. The neck positive wire connects to "Pole B" of the selector switch. The bridge positive wire connects to "Pole A" of the selector switch.