

BODYCRAFT

Xpress PRO STRENGTH TRAINING SYSTEM INSTRUCTION MANUAL

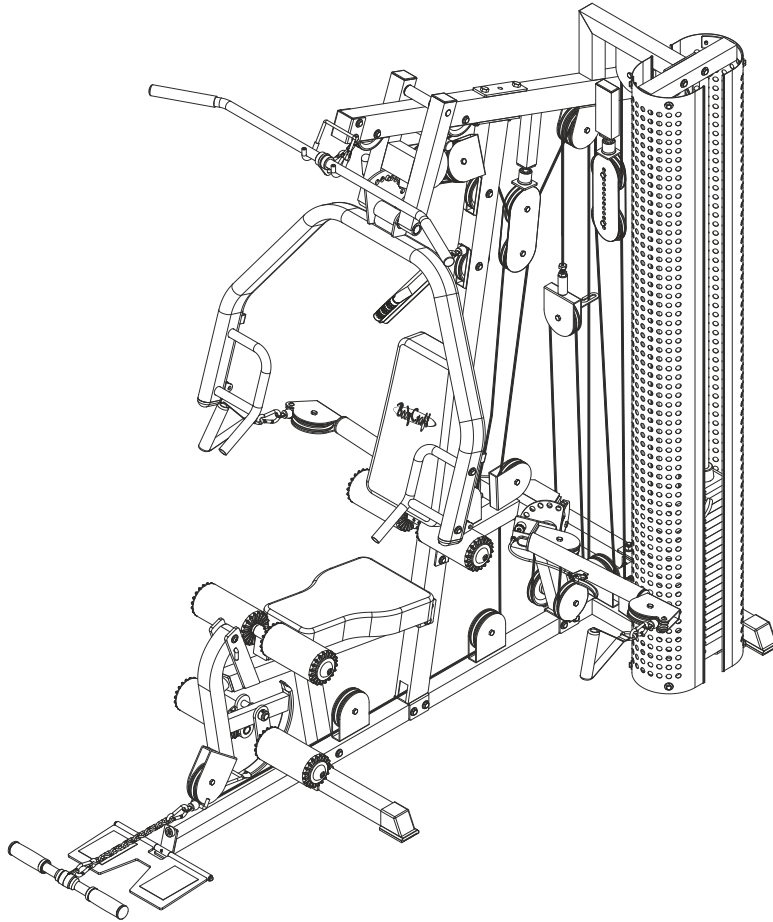

QUESTION?

As a quality home gym supplier we are committed to your complete satisfaction. If you have questions, or find missing or damaged parts, we will guarantee your complete satisfaction through our authorized dealer service centers or our home office customer service department. Please call your local dealer for assistance or BodyCraft at 800-990-5556 (9:00 AM - 5:00 PM). Our trained technicians will provide immediate assistance to you, free of charge.

Bodycraft is a division of Recreation Supply Inc.
7699 Green Meadows Dr
Lewis Center, OH 43035

78600A

BEFORE YOU BEGIN

Congratulations and thank you for selecting the **BODYCRAFT Xpress^{PRO}** strength training system. The **BODYCRAFT Xpress^{PRO}** offers an impressive array of strength training exercises to develop every major muscle group of the body. Whether your goal is cardiovascular fitness, a shapely, toned body or dramatic muscle size and strength, the **BODYCRAFT Xpress^{PRO}** will help you achieve the specific results you want.

For your safety and benefit, read this manual and the accompanying literature before using the **BODYCRAFT Xpress^{PRO}**. Keep this manual for future reference. If you have additional questions, please call your local **BODYCRAFT** dealer or our customer service department at 800-990-5556 Monday through Friday, 9 a.m. until 5 p.m. Eastern Time.

IMPORTANT SAFETY NOTES

There is a risk assumed by individuals who use this type of equipment. Before beginning this or any other exercise program consult your physician. This is especially important for individuals over the age of 35 or persons with pre-existing health problems. Recreation Supply, Inc. assumes no responsibility for personal injury or property damage sustained by or through use of this product.

1. This product must be assembled on a flat, level surface to assure its proper function.
2. Clean pads and frame on a regular basis. We recommend warm, soapy water. Do not use harsh or abrasive chemicals.
3. Inspect and tighten all parts before every use. Replace any worn parts immediately. Failure to do so may result in serious injury.
4. Keep children away from the **BODYCRAFT Xpress^{PRO}** at all times.
5. Keep your hands away from cables and pulleys during operation.
Keep your hands away from moving parts other than the designated handles.
6. When adjusting the seat, make sure the spring pin is fully engaged.
If not, the seat may slip and cause serious injury.
7. Make certain all cables are seated within the pulleys before every use.
8. Exercise with care to avoid injury.
9. If unsure about the proper use of the **BODYCRAFT Xpress^{PRO}** strength training system call your local **BODYCRAFT** dealer or our customer service department at 800-990-5556.

OVERVIEW

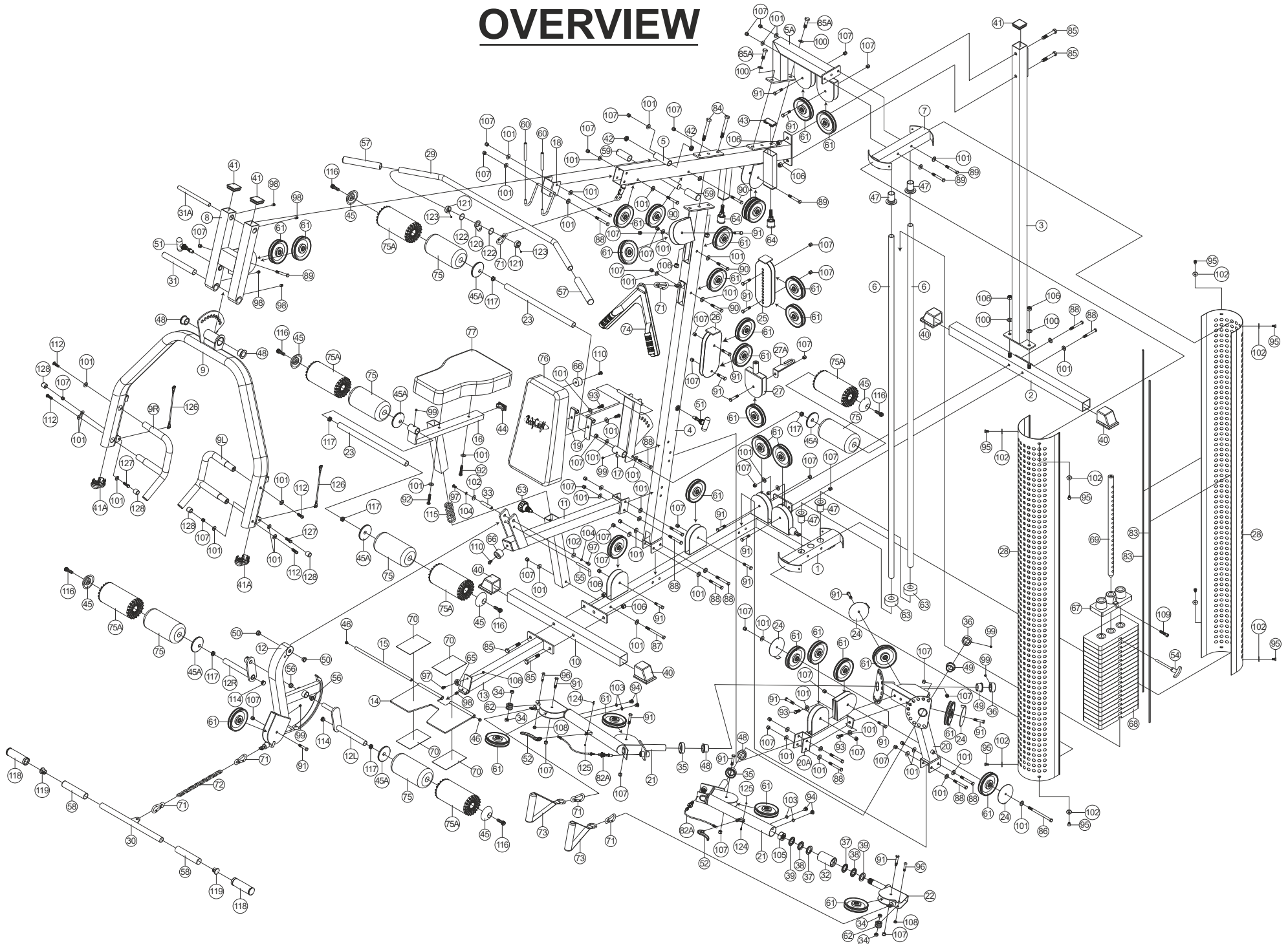

PARTS CHART

NO.	DESCRIPTION	QTY.
1	BASE FRAME	1
2	REAR STABILIZER	1
3	REAR UPRIGHT	1
4	FRONT UPRIGHT	1
5	TOP FRAME - bearing pre-installed	1
5A	TOP FRAME CONNECTOR	1
6	GUIDE ROD	2
7	TOP GUIDE ROD RETAINER	1
8	PRESS ARM SELECTOR	1
9	PRESS ARM	1
9R	RIGHT HANDLE OF PRESS ARM	1
9L	LEFT HANDLE OF PRESS ARM	1
10	FRONT STABILIZER	1
11	SEAT FRAME	1
12	LEG EXTENSION ARM - bearing pre-installed	1
12R	RIGHT LEG EXTENSION ARM	1
12L	LEFT LEG EXTENSION ARM	1
13	LOW ROW CONNECTOR	1
14	FOOT PLATE	1
15	FOOT PLATE ROLLER	1
16	CHROME SEAT ADJUSTER	1
17	SEAT BACK ADJUSTER	1
18	LAT BAR HOLDER	1
19	METAL HINGE	2
20	CABLE ARM ASSEMBLY	1
20A	CABLE ARM CONNECTOR	1
21	CABLE ARM	2
22	SWIVEL CABLE TOP	2
23	FOAM ROLLER BAR	2
24	PULLEY GUIDE BRACKET	4
25	ADJUSTABLE PULLEY BLOCK	1
26	DOUBLE PULLEY BLOCK	1
27	SINGLE PULLEY BLOCK	1
27A	CABLE GUIDE PLATE	1
28	WEIGHT SHROUD	2
29	LAT BAR	1
30	LOW ROW BAR	1
31	PIVOT AXLE	1
31A	19.92mm AXLE	1
32	CABLE ARM COLLAR	2
33	LEG EXTENSION AXLE	1
34	608ZB BEARING	4
35	STEEL SPACER	2
36	AXLE COLLAR	2
37	BEARING BASIN	4
38	BEARING	4
39	BEARING COVER	4
40	50mm SQ. CAP	4
41	50mm SQ. PLUG	3
41A	40 X 80mm ELLIPTIC PLUG	2
42	37mm OD. BEARING	2
43	25 X 50mm RECT. PLUG	1
44	30 X 60mm RECT. PLUG	1
45	PLASTIC COVER	6
45A	PLASTIC WASHER	6
46	1/2" ROUND PLUG	2
47	PLASTIC GUIDE ROD HOLDER	4
48	1" STEEL BUSHING	2
49	28.6mm STEEL BUSHING	4
50	1/2" X 1-1/8" BEARING	2

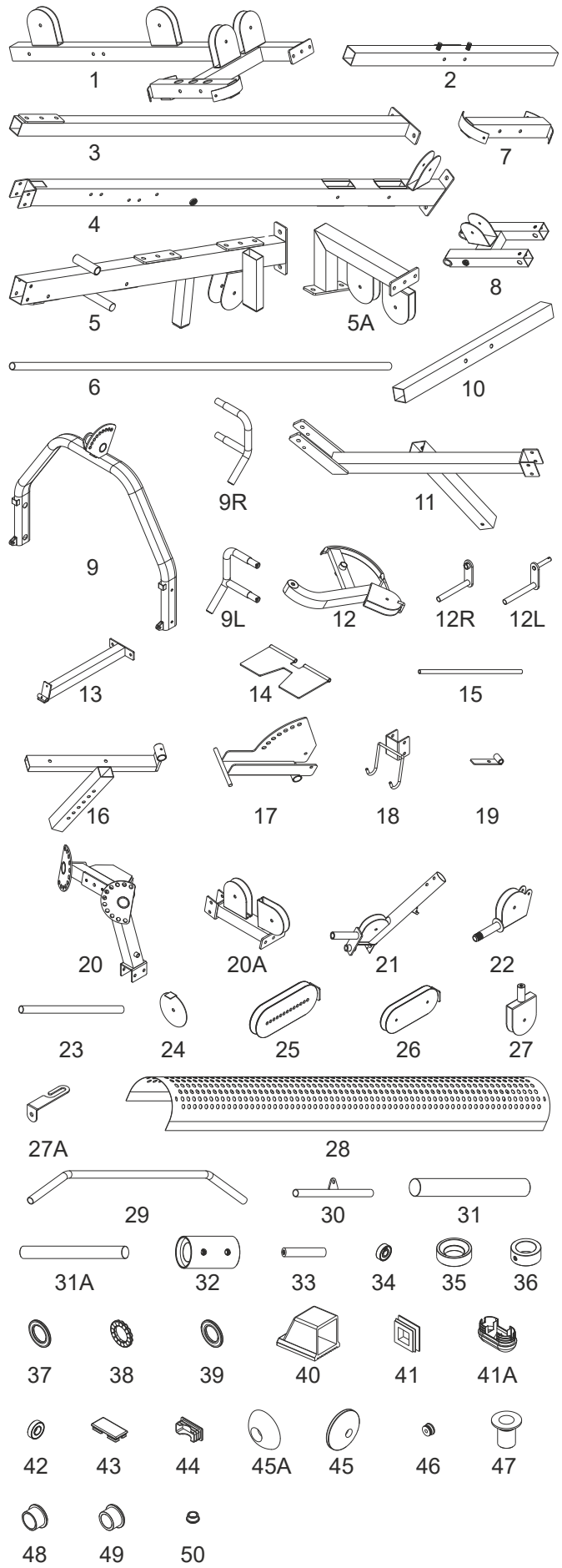





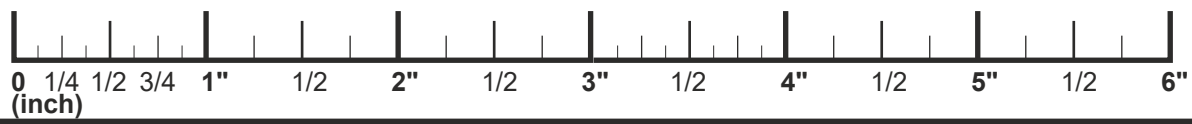
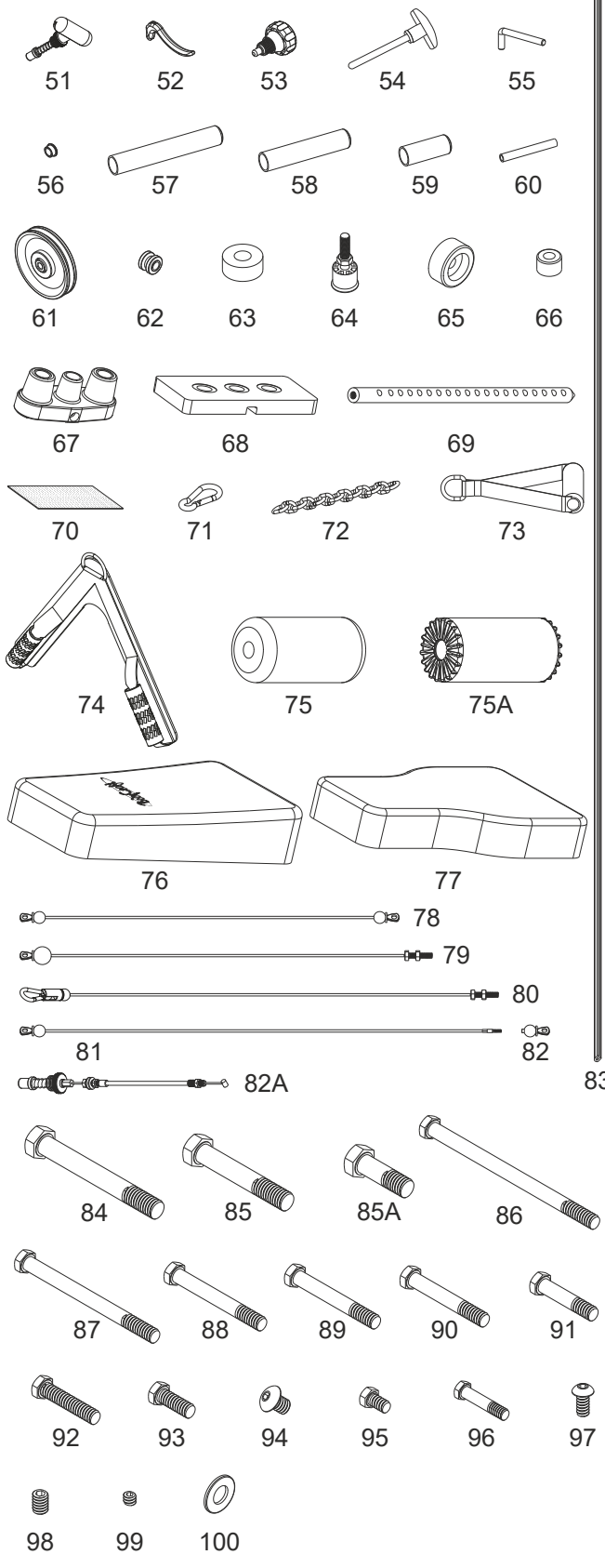





















PARTS CHART

NO.	DESCRIPTION	QTY.
51	RED POP PIN	2
52	CLUTCH LEVER OF CABLE ARM	2
53	SPRING KNOB	1
54	MAGNETIC SELECTOR PIN	1
55	L PIN	1
56	3/4" BUSHING	2
57	1" X 200mm HAND GRIP	2
58	1" X 140mm HAND GRIP	2
59	1" X 70mm PRESS ARM STOPPER	2
60	GRIP OF LAT BAR HOLDER (95mm)	2
61	BIG PULLEY	31
62	SMALL PULLEY OF SWIVEL ARM	2
63	RUBBER DONUT	2
64	ADJUSTABLE STOPPER	2
65	1/2" STOPPER	1
66	BACK BRACKET STOPPER	2
67	TOP PLATE	1
68	10 LB. PLATE	19
69	SELECTOR ROD	1
70	NON SLIP	4
71	SNAP HOOK	6
72	LOW ROW CHAIN	1
73	HAND GRIP OF CABLE ARM	2
74	NEW AB CRUNCH	1
75	FOAM PAD WITH VINYL COVER	6
75A	COVER OF FOAM PAD	6
76	BACK PAD	1
77	SEAT PAD	1
78	AB CRUNCH CABLE	1
79	CABLE ARM CONNECTING CABLE	1
80	TOP CABLE	1
81	CABLE ARM CABLE	1
82	HEAD OF CABLE ARM CABLE	1
82A	CLUTCH CABLE	2
83	BINDING OF WEIGHT SHROUD	4
84	1/2" X 4" HEX HEAD BOLT	2
85	1/2" X 3" HEX HEAD BOLT	4
85A	1/2" X 1-1/4" HEX HEAD BOLT	2
86	3/8" X 5-3/4" HEX HEAD BOLT	1
87	3/8" X 4-1/2" HEX HEAD BOLT	1
88	3/8" X 3" HEX HEAD BOLT	13
89	3/8" X 2-3/4" HEX HEAD BOLT	4
90	3/8" X 2-1/2" HEX HEAD BOLT	4
91	3/8" X 1-3/4" HEX HEAD BOLT	21
92	3/8" X 1-3/4" HEX HEAD BOLT (ALL)	2
93	3/8" X 1" HEX HEAD BOLT (ALL)	4
94	3/8" X 1/2" ROUND BOLT	4
95	5/16" X 1/2" HEX HEAD BOLT (ALL)	8
96	5/16" X 1-1/2" HEX BOLT	2
97	5/16" X 5/8" INNER HEX SCREW	3
98	3/8" X 5/8" SET SCREW	4
99	5/16" X 1/4" SET SCREW	5
100	1/2" WASHER	4



PARTS CHART

NO.	DESCRIPTION	QTY.							
101	3/8" WASHER	56							
102	5/16" WASHER	10							
103	3/8" SPRING WASHER	4	101	102	103	104	105	106	
104	5/16" SPRING WASHER	2							
105	1" NYLON NUT	2							
106	1/2" NYLON NUT	8							
107	3/8" NYLON NUT	46	107	108	109	110	111		
108	5/16" NYLON NUT	3							
109	TOP PLATE BOLT	1							
110	3/8" X 3/4" INNER HEX SCREW	2							
111	ANKLE STRAP	1							
112	3/8" X 1" INNER HEX SCREW	4	112	114	115	116	117		
114	1" PLUG	2							
115	SPRING	1							
116	5/16" X 32mm SUNKEN HEAD SCREW	6	118	119	120	121	122		
117	5/16" NUT	6							
118	1-1/4" HAND GRIP	2							
119	1" T SHAPE END PLUG	2							
120	HOOK PLATE	1	123	124	125	126			
121	COLLAR	2							
122	SEALING RING	2							
123	M6 SET SCREW	2							
124	M5 X 18mm ROUND HEAD SCREW	2	127	128					
125	M5 NYLON NUT	2							
126	CONNECT CABLE	2							
127	3/8" X 1-1/4" HEX BOLT	2							
128	CAP FOR 3/8" NUT	4							



STEP 1 ASSEMBLE MAIN FRAME

To ease the assembly process, do not tighten bolts until instructed.

1. Attach Rear Stabilizer(2) to Base Frame(1) using two 3/8"X3" Bolts(88), four 3/8" Washers(101) and two 3/8" Nuts(107). Attach Front Stabilizer(10) and Low Row Connector(13) to Base Frame(1) using two 1/2"X3" Bolts(85) and two 1/2" Nuts(106). Cap Rear Stabilizer(2) and Front Stabilizer(10) with four 50mm SQ. Caps(40).
2. Attach the Foot Plate(14) to Low Row Connector(13) by aligning the holes and inserting Foot Plate Roller(15). Insert two 1/2" Round Plugs(46) into the Foot Plate Roller(15).
3. Attach Rear Upright(3) to Rear Stabilizer(2) using two 1/2" Washers(100) and two 1/2" Nuts(106).
4. Attach Front Upright(4) to Base Frame(1) using two 3/8"X3" Bolts(88), four 3/8" Washers(101) and two 3/8" Nuts (107).
5. Attach Top Frame(5) to Front Upright(4) using two 1/2"X4" Bolts(84) and two 1/2" Nuts(106). Attach Top Frame(5) to Rear Upright(3) using two 1/2"X3" Bolts(85) and two 1/2" Nuts(106).
6. Insert four Plastic Guide Rod Holders(47) into Base Frame(1) and Top Guide Rod Retainer(7) as shown. Slide a Rubber Donut(63) onto one end of each Guide Rod(6) and then insert the Guide Rods(6) into the Plastic Guide Rod Holders(47) in Base Frame(1) as shown.
7. Slide each 10 Lb. Plate(68) over Guide Rods(6). Make certain that each plate is oriented with selector hole on bottom and facing forward. Attach Top Plate(67) to Selector Rod(69) using Top Plate Bolt(109). Slide Top Plate(67) and Selector Rod(69) onto Guide Rods(6).
8. Attach the Top Frame Connector(5A) to the Top Frame(5) using two 1/2"X1-1/4" Bolts(85A) and two 1/2" Washers(100). Slide the Top Guide Rod Retainer(7) over top of the Guide Rods(6) and then attach the Top Guide Rod Retainer(7) to the Top Frame Connector(5A) using two 3/8"X2-3/4" Bolts(89), four 3/8" Washers(101), and two 3/8" Nuts(107). Attach a 50mm SQ. Plug(41) to the top of the Rear Upright(3), and a 25X50mm RECT. Plug(43) to the rear of the Top Frame(5).

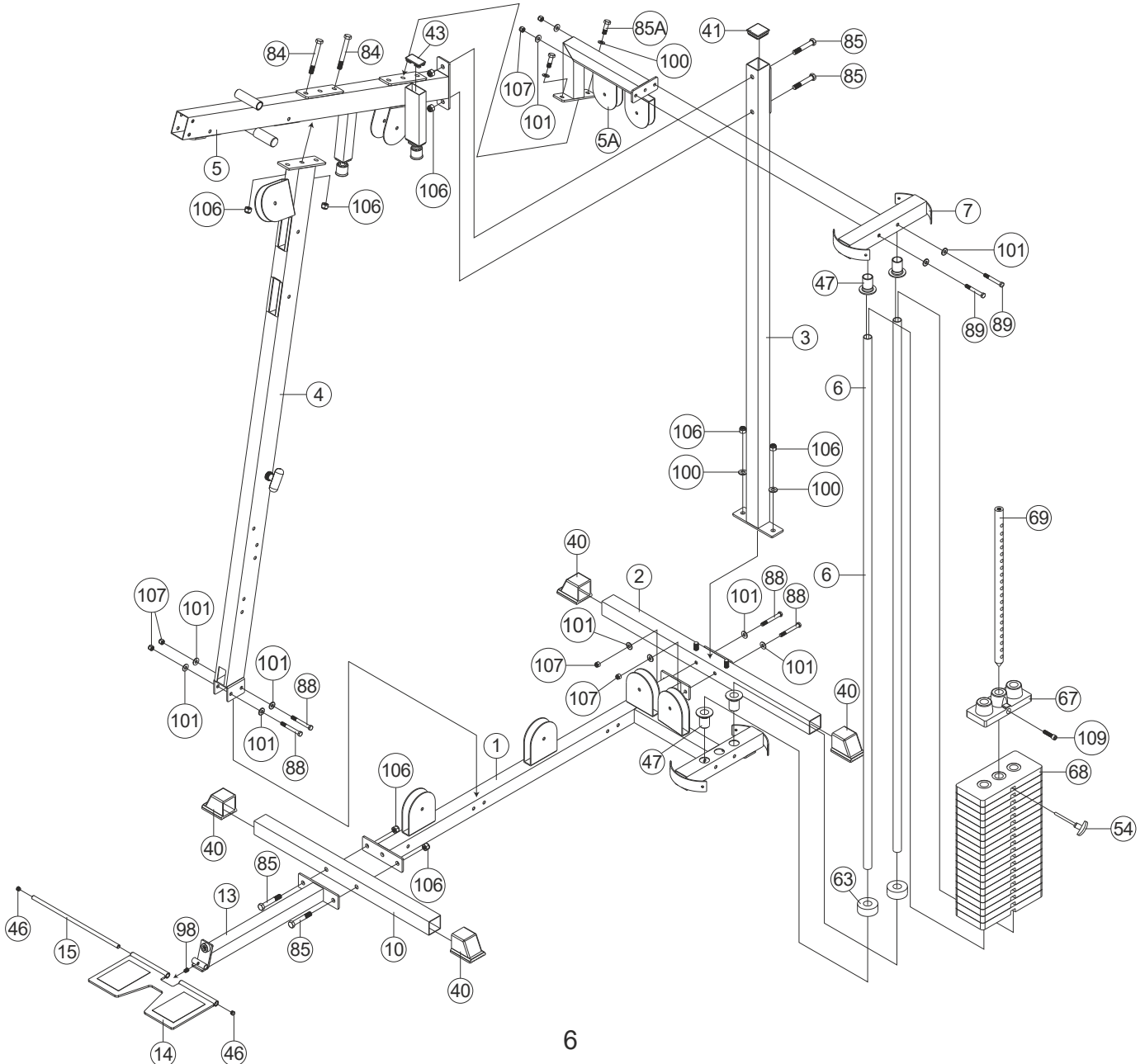

STEP 2 ASSEMBLE PRESS ARM & CABLE ARM ASSEMBLY

1. Attach Press Arm Selector(8) to Top Frame with bearing pre-installed(5) by aligning holes and inserting 19.92mm Axle(31A). Lock into place with pre-installed set screw.
2. Attach Press Arm(9) to Press Arm Selector(8) by aligning holes and inserting Pivot Axle(31). Lock into place with pre-installed set screw.
3. Attach 40X80mm Elliptic Plugs(41A) onto ends of Press Arm(9) and attach 50mm SQ. Plug(41) onto ends of Press Arm Selector(8).
4. Attach Cable Arm Connector(20A) to Cable Arm Assembly(20), using two 3/8"X1" Bolts(93) and two 3/8" Washers(101). Attach Cable Arm Connector(20A) to Front Upright(4) and Cable Arm Assembly(20) to Base Frame(1), using four 3/8"X3" Bolts(88), eight 3/8" Washers(101) and four 3/8" Nuts(107). Remember to keep all bolts loose to ensure holes will align easily. Slide the axle of each Cable Arm(21) through the hole in selector plate of Cable Arm Assembly(20) and fasten using Axle Collar(36) with 5/16"X1/4" Set Screw(99). Check to ensure that each arm pivots freely and any cables are not twisted.
5. Attach Lat Bar Holder(18) to Top Frame(5) using two 3/8"X3" Bolts(88), four 3/8" Washers(101) and two 3/8" Nuts(107).

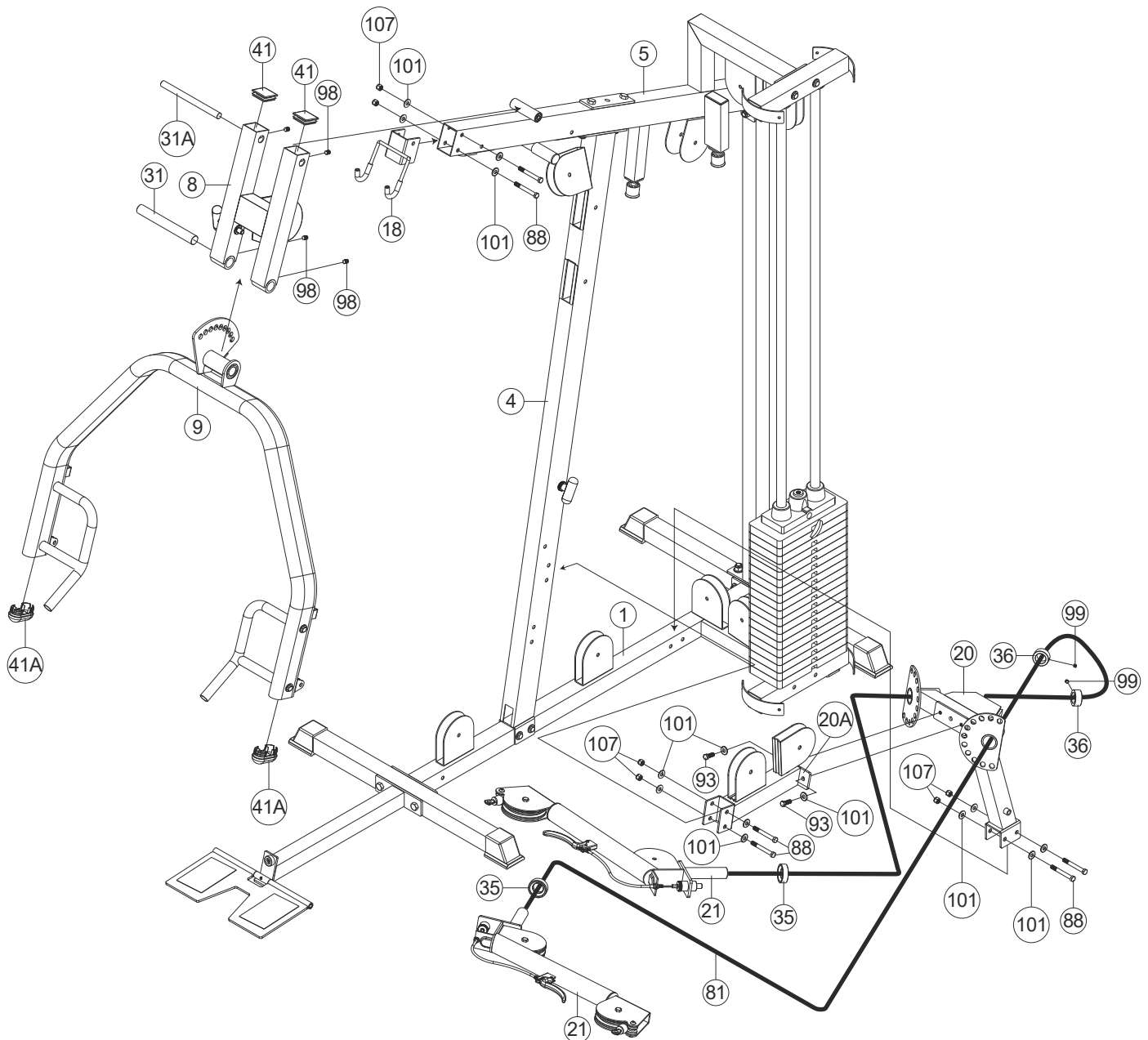

STEP 3 ASSEMBLE SEAT FRAME AND SEAT BACK

1. Attach Seat Frame(11) to Front Upright(4) using two 3/8"X3" Bolts(88), four 3/8" Washers(101) and two 3/8" Nuts(107). Attach Seat Frame(11) to Base Frame(1) using 3/8"X4-1/2" Bolt(87), two 3/8" Washers(101) and one 3/8" Nut(107).
2. Attach Leg Extension Arm with bearing pre-installed(12) to Seat Frame(11) by aligning holes and then inserting Leg Extension Axle(33). Fasten Leg Extension Axle(33) using two 5/16" Spring Washers(104), two 5/16" Washers(102) and two 5/16"X5/8" Set Screws(97). Check to ensure that Leg Extension Arm(12) pivots freely. Attach the Right and Left Leg Extension Arms(12R & 12L) to the Leg Extension Arm(12) by 5/16"X1/2" Set Screw(113). Moisten the center of two Cover of Foam Pads(75A) and slide onto each end of the Right and Left Leg Extension Arms(12R & 12L). Attach Plastic Washer (45A) at both side of Cover of Foam Pad(75A) and secure the pads with 5/16"x32mm Sunken Head Screw(116). Note: The L Pin(55) is used to lock the Leg Extension Arm(12) into place when using the low cable for exercises such as arm curls, leg kicks, upright rows, etc. Remove the L Pin(55) when performing leg extensions and leg curls.
3. Insert Foam Roller Bar(23) into hole in Chromed Seat Adjuster(16). Moisten Foam Pad(75) with water and slide onto each end of Foam Rollers Bar(23). Attach Plastic Washer(45A) to both side of Cover of Foam Pad(75A) and secure the Pads with 5/16"X32mm Sunken Head Screw(116).
4. Attach Seat Pad(77) to Chromed Seat Adjuster(16) using two 3/8" Washers(101) and two 3/8"X1-3/4" Bolts(92). Attach 25X50mm Plug(44) to Chromed Seat Adjuster(16) and 50mm SQ. Plug(41) to Seat Frame(11). Insert Chromed Seat Adjuster(16) into Seat Frame(11) and lock into place with Pop Pin(53) with Spring(115).
5. Attach Seat Back Adjuster(17) to Front Upright(4) using one 3/8"X3" Bolt(88), two 3/8" Washers(101) and 3/8" Nut(107). It may be necessary to tighten this bolt, then loosen just enough to let Seat Back Adjuster(17) pivot freely. Attach Pop Pin(53) for Seat Back Adjuster(17) to Front Upright(4). Attach two Metal Hinges(19) to top of Seat Back Adjuster(17), then attach Back Pad(76) to Metal Hinges(19) using two 3/8"X1-3/4" Bolts(93) and two 3/8" Washers(101). Insert Foam Roller Bar(23) into hole in Seat Back Adjuster(17). Moisten two Foam Pads(75) with water and slide onto each end of Foam Roller(23), then attach Plastic Washer(45A) at both side of Cover of Foam Pads(75A) and secure pads with 5/16"x32mm Sunken Head Screw(116). Lock into place with pre-installed Set Screw.
6. Attach Weight Shroud(28) to Base Frame(1) and Top Guide Rod Retainer(7) using four 5/16"X1/2" Bolts(95) and four 5/16" Washers(102).

Tighten all the bolts and nuts gradually.

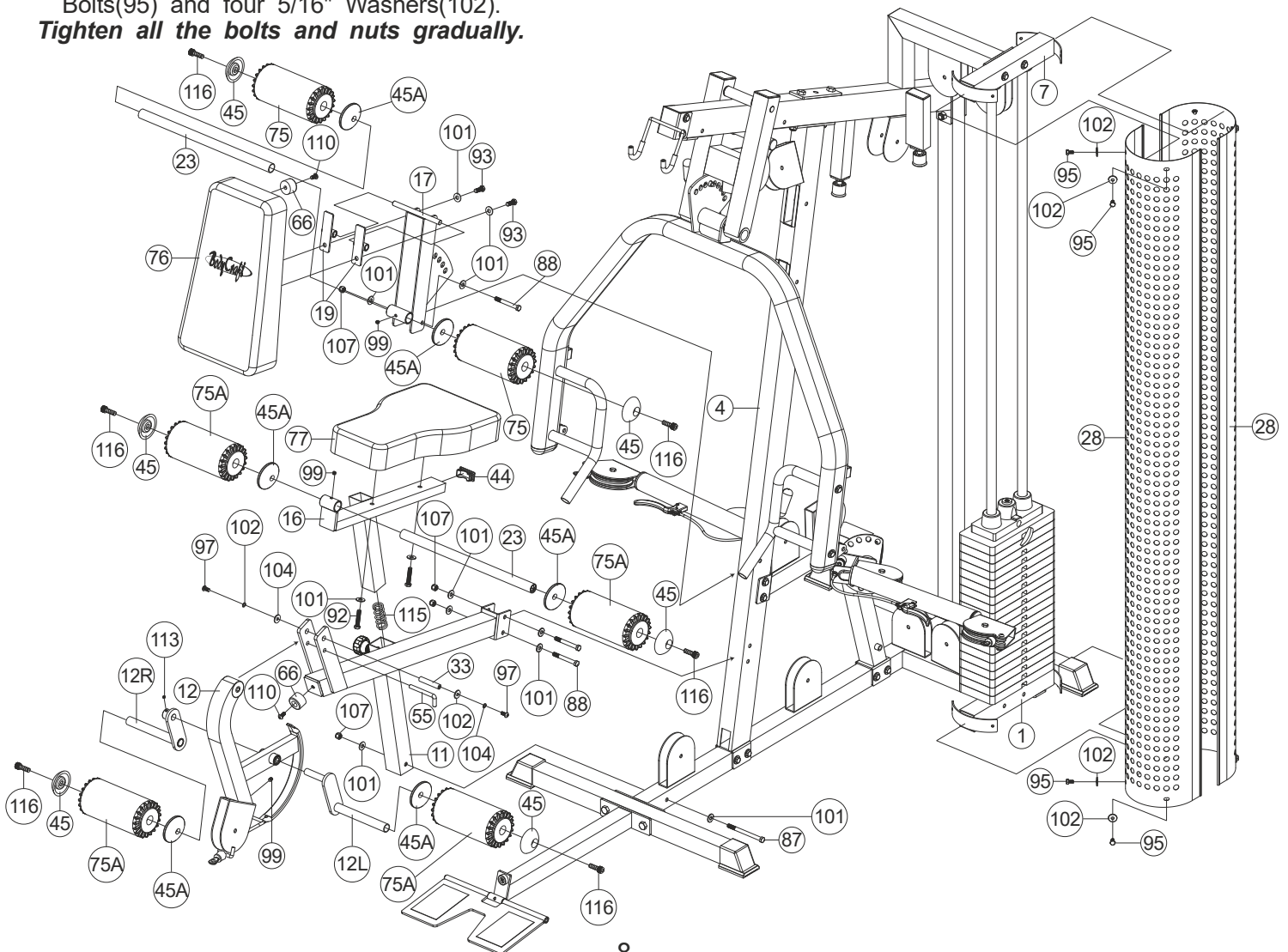

TOP CABLE

Assemble cables and pulleys simultaneously.

Insert threaded end of Top Cable(80) into the slot in front of Top Frame(5)(Fig 1) and route over top of two pulleys mounted in Top Frame(5)(Fig 1, 2), over left side (as if sitting on seat) pulley in Press Arm Selector(8)(Fig 3, Step 1), under pulley mounted in Front Upright(4), over right side pulley in Press Arm Selector(8)(Fig 3, Step 2), then over pulley mounted in Front Upright(4)(Fig 3, Fig 4), down to top Double Pulley Block(26)(Fig 5), up and over left side pulley on Top Frame(5)(Fig 6), down and around top pulley in Adjustable Pulley Block(25)(Fig 7), up and over two Top Frame(5)(Fig 8)pulleys leading to weight stack. Screw cable end into Selector Rod(69)(Fig 9). Attach Lat Bar 29 as shown in Fig 10.

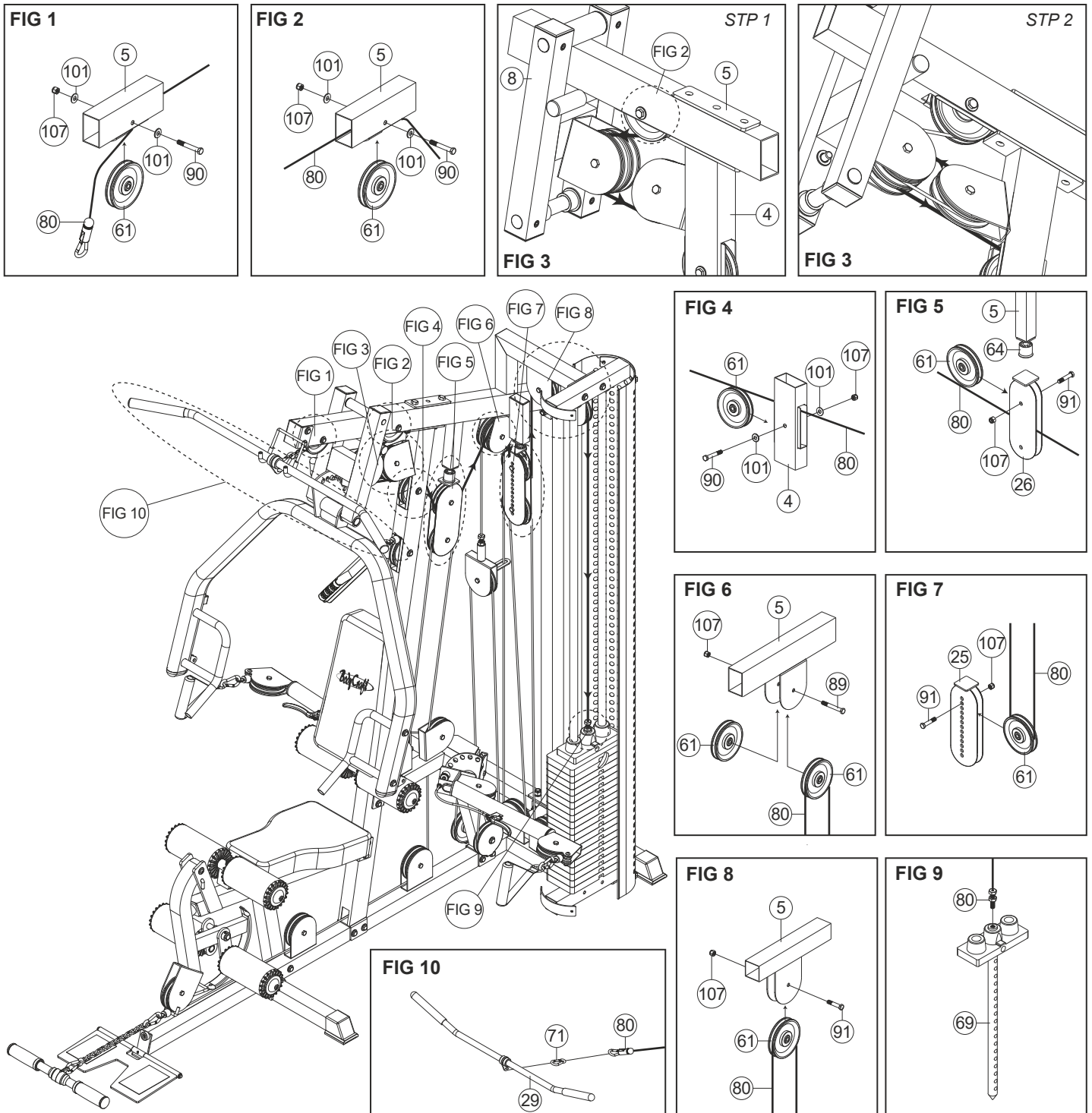

AB CRUNCH CABLE

Route the AB Crunch Cable(78) through slot and over pulley on Front Upright(4)(Fig 1), down to the front pulley on top of Cable Arm Assembly(20)(Fig 2), then up to lower pulley on Double Pulley Block(26)(Fig 3), down through the rear pulley on Cable Arm Assembly(20)(Fig 4) to pulley on Base Frame(1)(Fig 2), then forward toward Leg Extension Arm(12). Route AB Crunch Cable(78) under both pulleys on Base Frame(1) and under pulley on Leg Extension Arm(12).

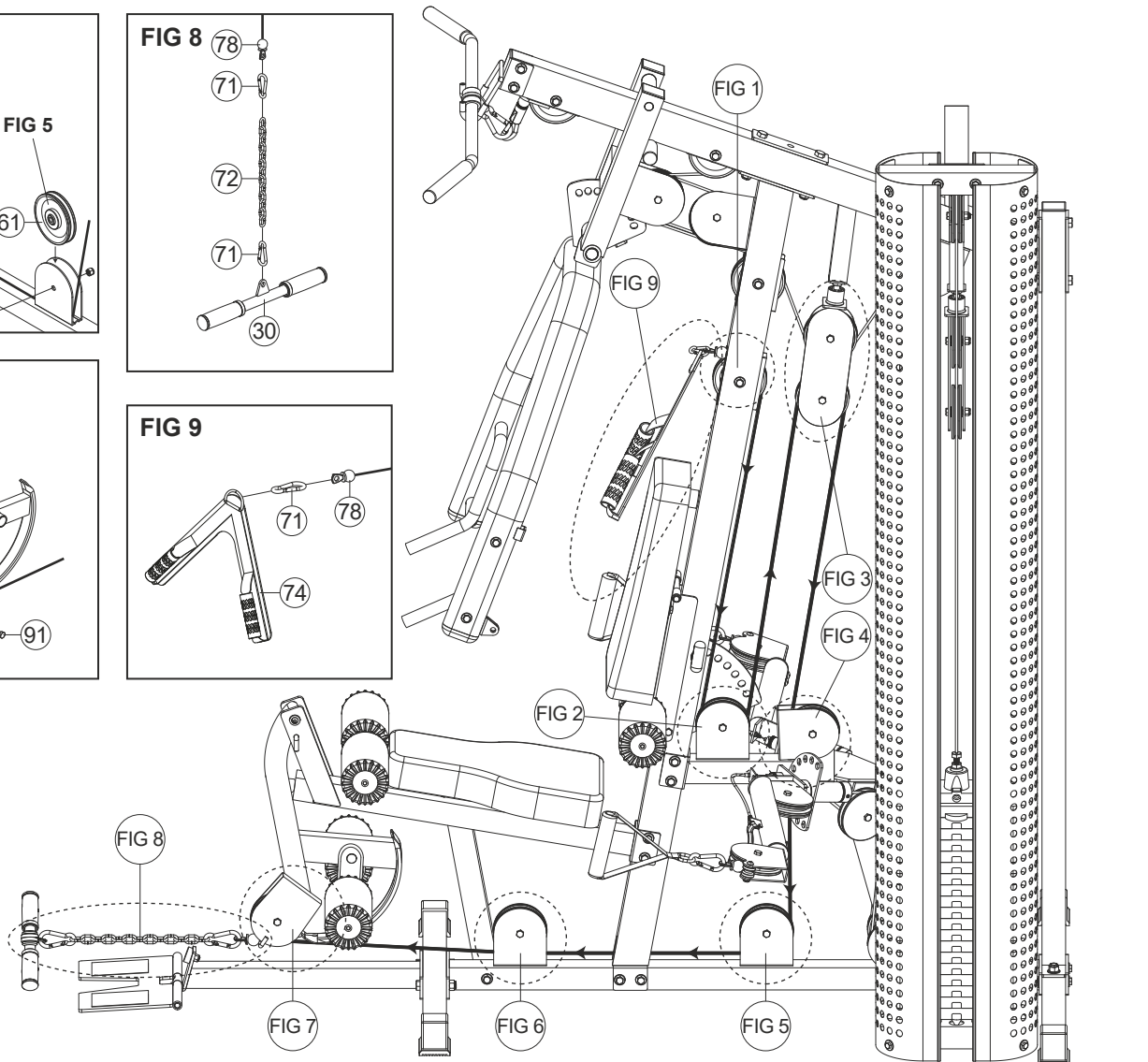
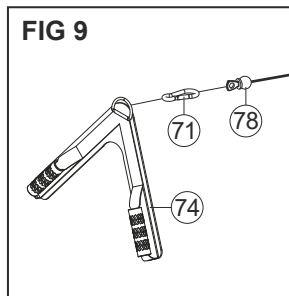
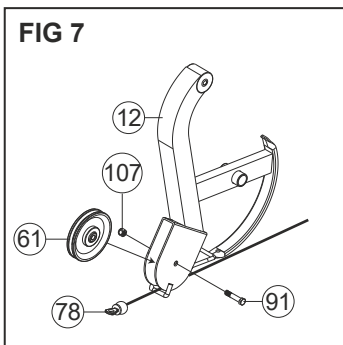
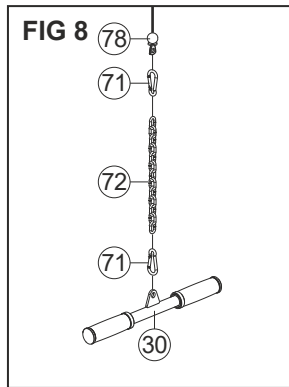
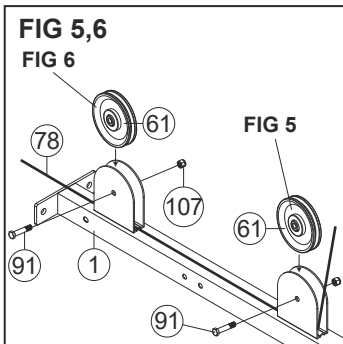
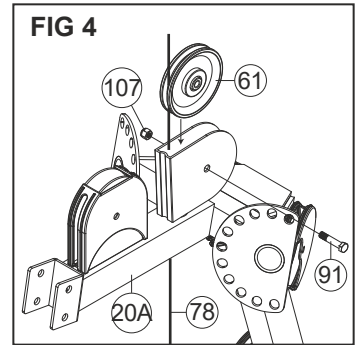
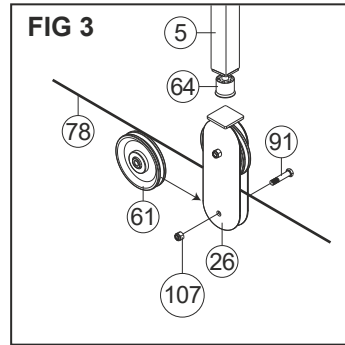
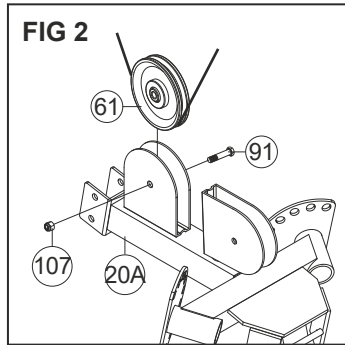
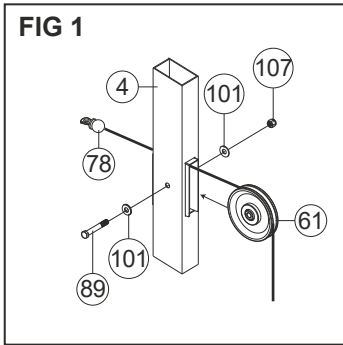

CABLE ARM CONNECTING CABLE

Attach pulley on Base Frame(1) near weight stack as shown Fig 1 with ball end of cable toward weight stack. Route cable up to low pulley of Adjustable Pulley Block(25)(Fig 2), then down to pulley on Base Frame(1)(Fig 3), up to right side pulley in Top Frame(5)(Fig 4) and thread into the Single Pulley Block(27)(Fig 5).

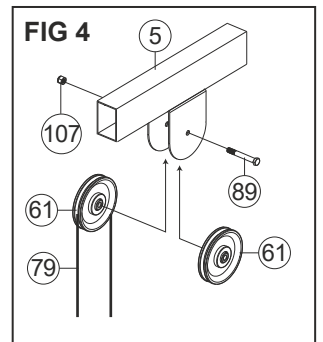
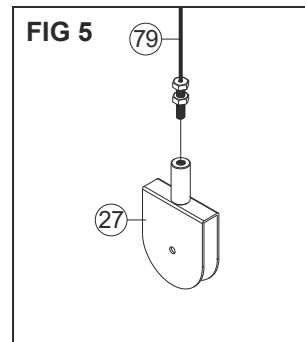
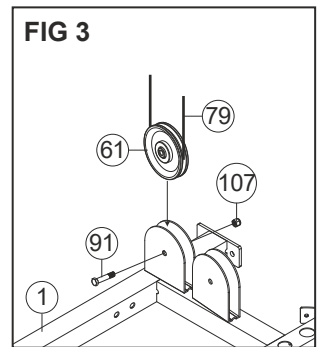
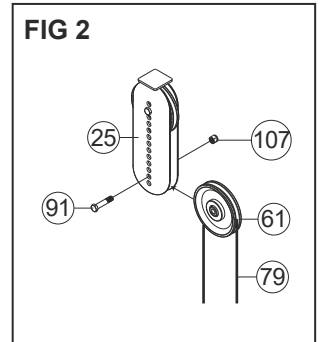
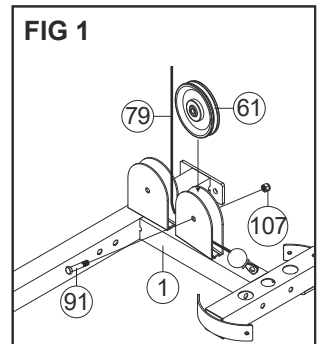
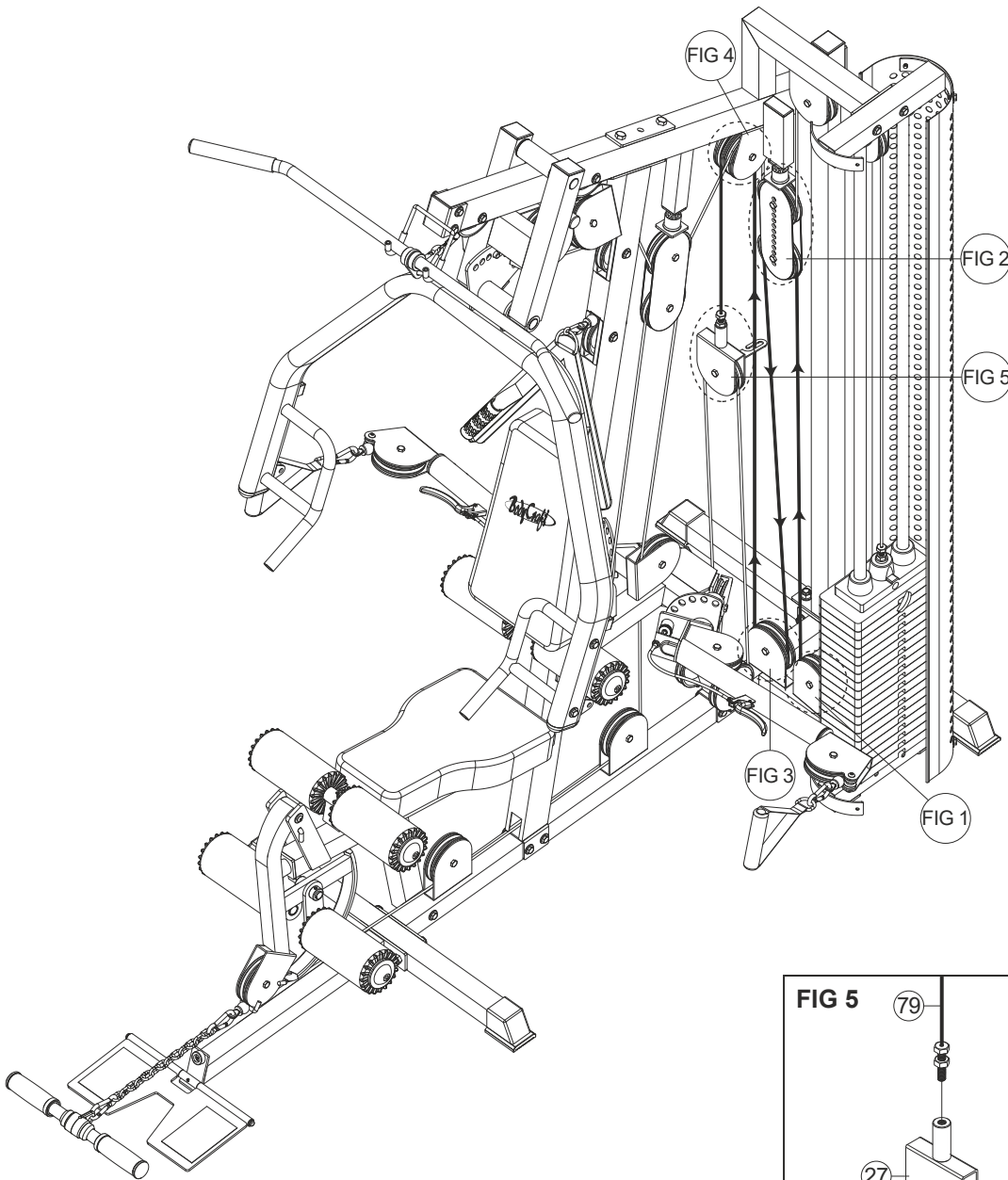

CABLE ARM CABLE

Attach pulley and Pulley Guide Bracket(24) to Cable Arm Assembly(20) as shown in Fig 3 and Fig 4, Be certain that, when tightened, the Pulley Guide Brackets(24) do not interfere with the cable movement.

Route Cable Arm Cable(81) around these pulleys as shown and around pulley in the Single Pulley Block(27)(Fig 5).

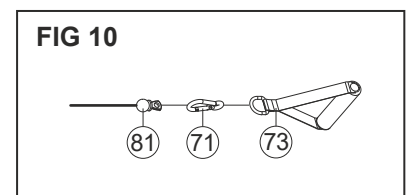
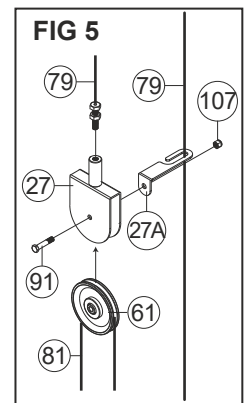
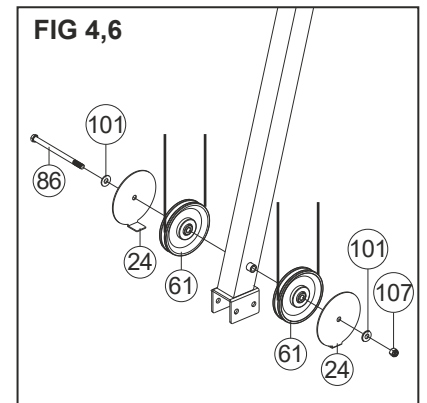
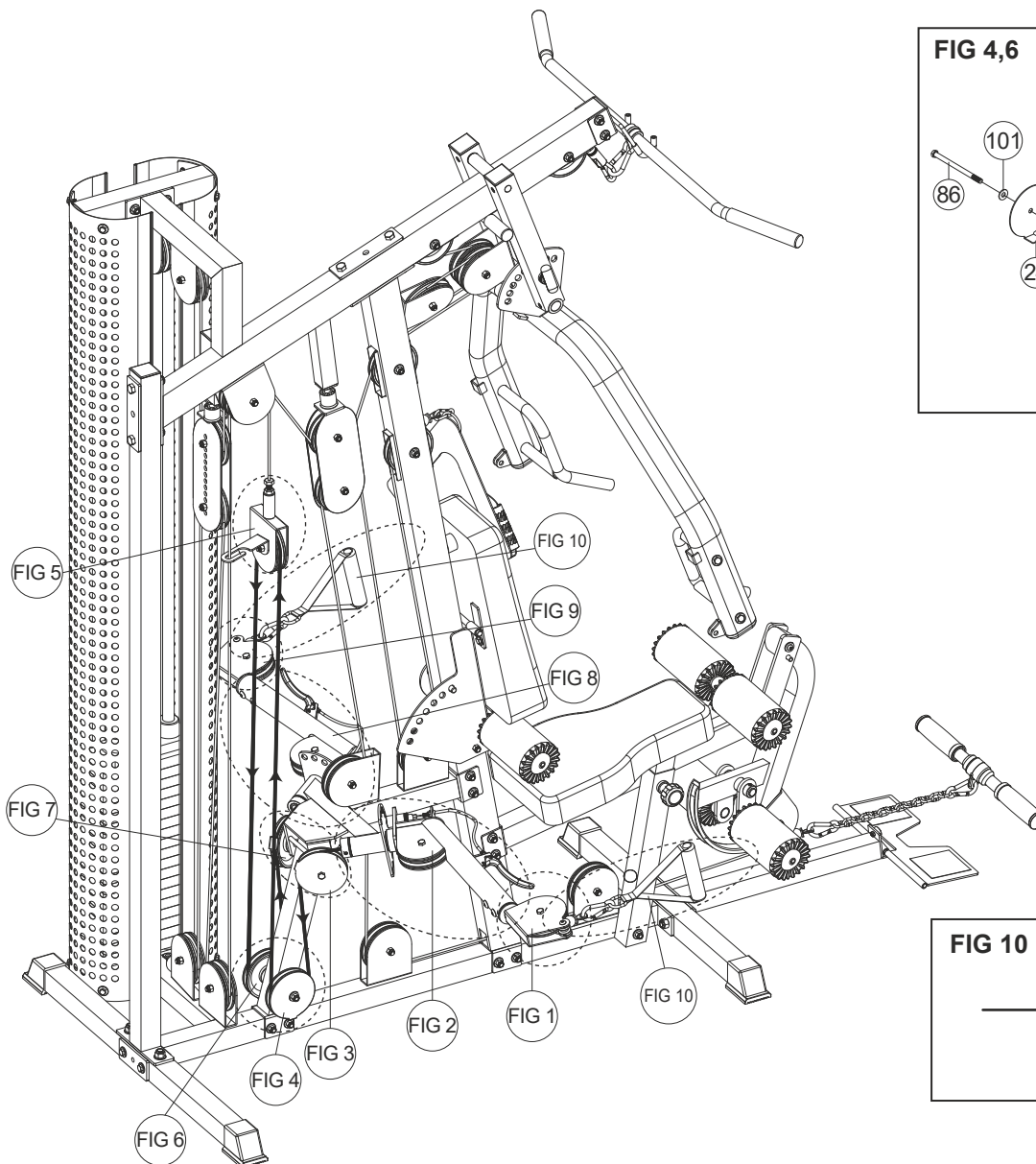
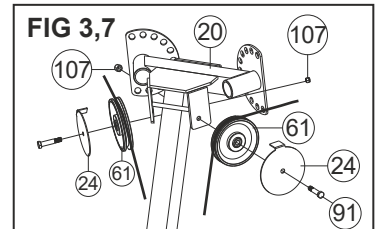
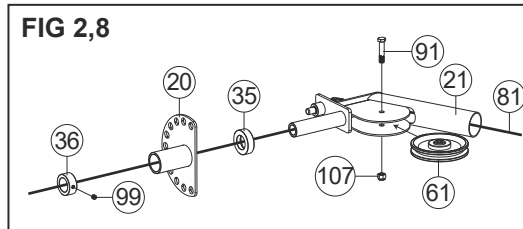
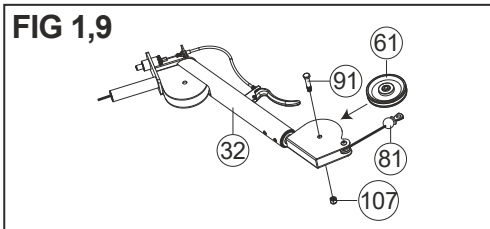

Step 12 The Cable Adjustment of X Press Pro

- a. The Cables should be tightened to the point just before the Top Plate lifts off the stack. In other words, if the Top Plate is not resting on the stack, you will need to add length, or, if there is slack in the cables, you will need to shorten the cables. There are several adjustment points. If only minor adjustments need to be made, you can adjust the Screw ends on the Top Cable (at the Top Plate), the Low Cable (where it screws into the Pulley Block), or the Bench Press Cable (where it screws into the Pulley Block with Stopper). **These ends of these cables must be screwed in at least 1/3 of their length for safety purposes.** Once you are done with these adjustments, lock them into place using the jam nuts.
- b. Broader adjustments are made at the Floating Pulley Block (25). Moving the bottom pulley toward the center decreases length (takes up slack). Conversely, moving the bottom pulley outward gains cable length.
- c. Once the cables have been adjusted to remove all slack, adjust the Adjustable Stoppers in the Top Frame to where they just touch the Floating Pulley Block (25), and the Pulley Block (26). The Adjustable Stoppers welded on top frame aid in the function of the gym by eliminating the need to engage all cables in any given exercise routine.

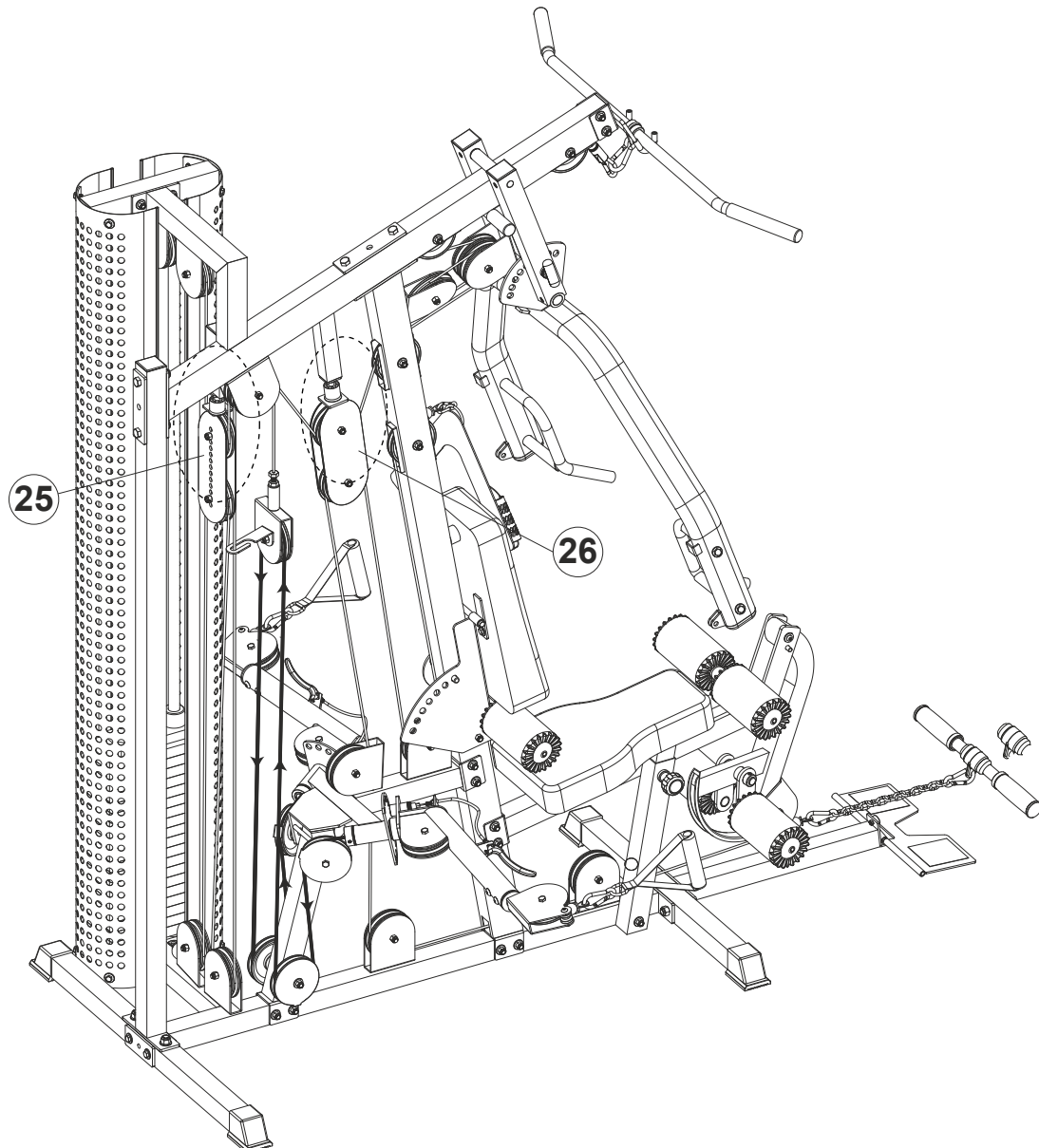

Assembly is complete! Please take the following steps before using the gym:

1. Make certain all bolts are tightened securely.
2. Make certain all cables are seated into all pulley grooves. A cable rubbing against steel will peel the nylon coating, voiding warranty and resulting in a need for replacement.
3. Pre-stretch the cables. Put the Weight Selector Pin (54) in the bottom hole on the weight stack. Pull on the cables with great force, helping remove any kinks and providing any initial cable stretch.
4. Be aware the cables can loosen and slightly stretch upon initial use.
5. The cables should be adjusted as tight as possible, but not so tight as to lift the Top Plate (67) above the weight stack. Be certain to secure the jam nuts after adjustments are made.
6. For better performance, apply a household lubricant (such as silicone) to any adjustable areas and to the Guide Rods (6).
7. Enjoy many years of a Fit Lifestyle.

Thank you for purchasing the Bodycraft X Press Home Gym. If You have any questions, please call your local BodyCraft dealer or call our customer service department at 800-990-5556