

BODYCRAFT

VR400

COMMERCIAL ROWING MACHINE



OWNERS • MANUAL



INTRODUCTION

Congratulations !

Thank you for selecting the VR400 Rower. The VR400 Air/Magnetic Rower is one of the the finest and most comprehensive rowing machines available.

By choosing the Bodycraft VR400 you have made a decision that will improve the health, fitness and well being for you and your family. The VR400 will provide an efficient, low impact cardiovascular workout that will help improve your energy levels and your quality of life.

Cardiovascular training is vital for all ages and the Bodycraft VR400 will provide an effective workout, producing results that will encourage you to reach your fitness goals and maintain the body you have always wanted.

Spending 15 to 30 minutes a day, three times a week is all you need to start the benefits of a regular exercise program.

We, at Bodycraft want you to enjoy the full benefits of your exercise program, so please take the time to read this manual thoroughly. By doing so you will:

- Save valuable time by learning proper use.
- Exercise safely and more effectively.
- Learn proper techniques.
- Be able to better define your fitness goals.

TABLE OF CONTENTS

INTRODUCTION -----	1
TABLE OF CONTENTS -----	1
BENEFITS OF EXERCISE -----	2
MEDICAL/SAFETY NOTICE -----	2
CARE AND MAINTENANCE -----	2
FEATURES OF THE AIR MAGNETIC ROWER -----	3
TRAINING TIPS -----	4
TRAINING GUIDELINES -----	4-6
SETTING UP YOUR ROWER -----	7-9
CORRECT ROWING GUIDE -----	10-11
STRETCHING -----	12
WIRELESS HEART RATE DISPLAY ISSUES / DIAGNOSIS CHECKLIST -----	13
ASSEMBLY INSTRUCTIONS -----	15-19
COMPUTER MANUAL -----	20-26
WARRANTY -----	back cover

BENEFITS OF EXERCISE

Regular exercise improves both the quality and quantity of life.

The benefits of regular participation in a well-balanced fitness program include:

1. Weight loss
2. Improved body shape and definition
3. Increased muscle mass, strength, endurance, power and definition
4. Enhanced flexibility
5. Increased metabolism
6. Injury prevention
7. Improved self-esteem
8. Improved aerobic fitness
9. Improved coordination and agility

A regular exercise program will improve the quality of your life, give you more energy and slow down the aging process.

Fifteen to thirty minutes, three times a week, or only one and a half hours a week is a small price to pay for huge benefits of a regular exercise program.

MEDICAL / SAFETY NOTICE

Failure to read and follow the safety instructions below and in the Owner's Manual may result in serious injury or even death.

1. Read the Owner's manual and all safety instructions thoroughly and familiarize yourself with the Air Magnetic Rower before using it.
2. Before beginning any exercise program, consult your physician. He or she can help evaluate your present fitness level and determine the exercise program that is the most appropriate for your age and physical condition.
3. If you experience any pain or tightness in your chest, irregular heartbeat, and shortness of breath, faintness or unusual discomfort during exercising, stop and consult a physician before continuing.
4. Adult supervision is required at all times when a child is on or near the Rower.
5. Keep fingers and limbs, loose clothing and hair away from moving parts.
6. All equipment should be checked for wear before each use. Do not use this equipment unless all moving parts are working correctly.
7. Care should be taken when getting on or off this or any exercise equipment
8. Use only the accessory attachments recommended by the manufacturer.
9. All equipment should be set up and operated on solid, level surfaces.

CARE AND MAINTENANCE

Your Rower is made of the highest quality materials. It is so important that you take care of your Rower on a regular basis.

1. Your Air Magnetic Rower is for indoor use only and should not be used or stored in damp areas. Wipe all perspiration from your Air Magnetic Rower after each use.
2. The Air Magnetic Rower should be dusted and cleaned on a regular basis to stop build-up of dust. Use Windex or an alcohol-based cleaner on a clean cloth on a regular basis. Do not use any abrasive cleaners, as this will damage the surface.



3. To ensure that the seat runs smoothly the roller track of the monorail and the rollers need special cleaning with oil based furniture polish.
4. Regularly check tightness of nuts, bolts and pins, etc.

FEATURES OF THE AIR MAGNETIC ROWER

The Air Magnetic Rower allows you all the advantages of a full sized rowing machine in a compact, folding design.

The Air Magnetic Rower provides smooth and variable exercise capabilities with:

- Full range Resistance Control
- Adjustable Foot Pedals.
- Ergonomic rowing action.
- Full Electronics package.
- Strong stable fold-up frame.
- Chest Band Pulse Transmitter (Optional)

DESIGNS NOTE :

The return spring on this Air Magnetic Rower has been designed with the lightest possible force. There is more than sufficient spring tension to recoil the polyester strap regardless of the return speed of the handle to the start position.

The reason for the light return spring is to give the user an improved level of exercise by increasing the benefit to the hamstring group of muscles at the rear of the thigh. This muscle group is called upon when the user moves the seat forward.

We have faithfully duplicated the “normal” rowing action one would get when rowing on water where the oar is not pulled forward.

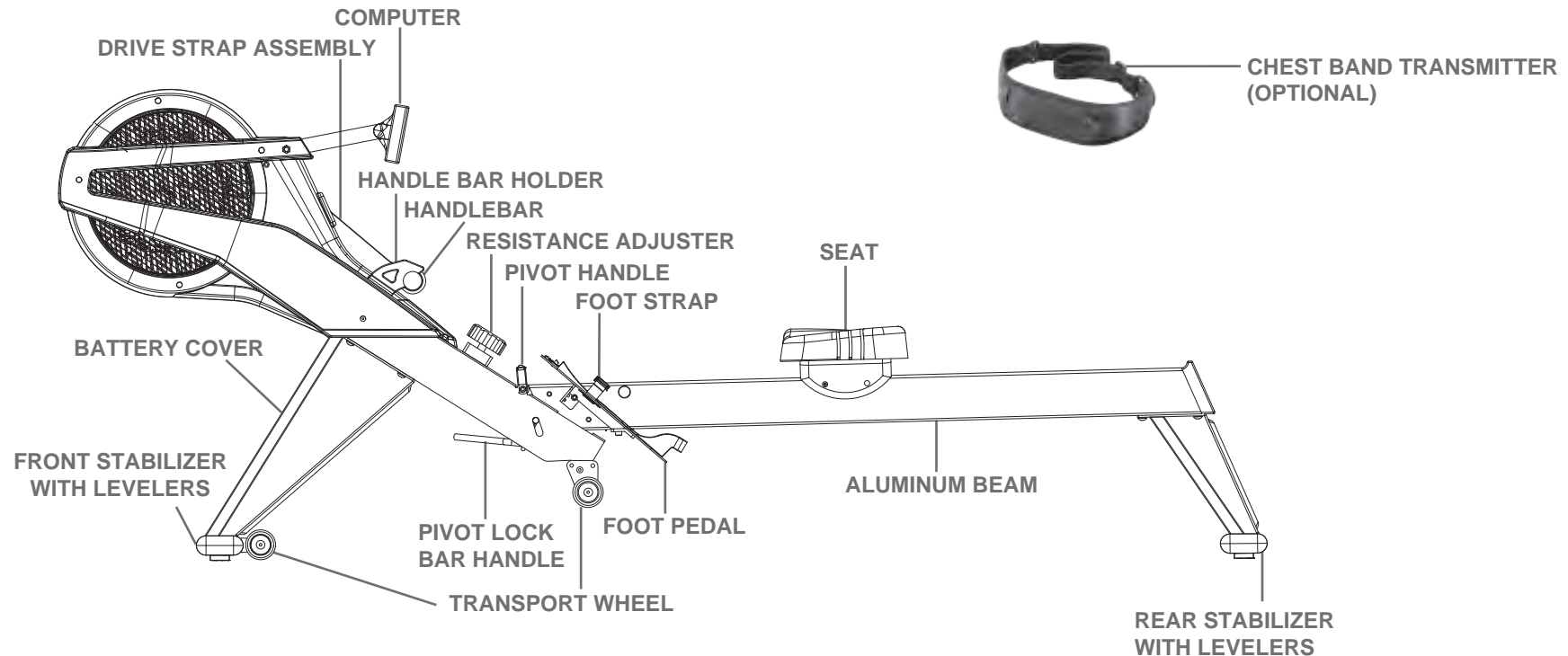

TRAINING TIPS

Rowing machines have been around for many years and were one of the earliest exercise machines.

Many people know how to row and there is very little one can do wrong. However, there are few pointers we can give you to reduce strain on your back and other joints and muscles. Rowing, more than any other aerobic exercise, utilizes the back muscles and the spine to transfer the pulling force from the arms (holding the handle) to the legs (providing most the pulling power).

To reduce excessive strain on the back muscles, spine, shoulders, arms and wrists we strongly suggest that you to keep your back straight throughout the entire rowing action. When moving forward to the start position bend at the hips, don't overreach (trying to stretch forward too much) and keep your arms straight. Pull the handle to your stomach, not your chest and keep your elbows in at your sides during the entire stroke with your wrists straight. When moving forward to the start position bend at the hips, don't overreach (trying to stretch forward too much) and keep your arms straight. Pull the handle to your stomach, not your chest and keep your elbows in at your sides during the entire stroke with your wrists straight.

TRAINING GUIDELINES

EXERCISE

Exercise is one of the most important factors in the overall health of an individual. Listed among its benefits are:

- Increased capacity for physical work (strength endurance)
- Increased cardiovascular (heart and arteries / veins) and respiratory efficiency.
- Decreased risk of coronary heart disease changes in body metabolism, e.g. losing weight.
- Delaying the physiological effects of age physiological effects, e.g. reduction in stress, increase in self-confidence, etc.

Your Rower's unique design provides an excellent opportunity for a high level of overall fitness.

Basic Components of Physical Fitness

There are four all-encompassing components of physical fitness and we need to briefly define each and clarify its role.

Strength is the capacity of a muscle to exert a force against resistance. Strength contributes to power and speed and is of great importance to a majority of sports people.

Muscular Endurance is the capacity to exert a force repeatedly over a period of time, e.g. it is the capacity of your legs to carry you 0 km without stopping.

Flexibility is the range of motion about a joint. Improving flexibility involves the stretching of muscles and tendons to maintain or increase suppleness, and provides increased resistance to muscle injury or soreness.

Cardio-Respiratory Endurance is the most essential component of physical fitness. It is the efficient functioning of the heart and lungs.

What to wear

Wear clothing that will not restrict your movement in any way while exercising.

Cloths should be light enough to allow the body to cool. Excessive clothing that causes you to perspire more than you normally would while exercising, gives you no advantage. The extra weight you lose is body fluid and will be replaced with the next glass of water you drink.

It is advisable to wear a pair of gym or running shoes or "sneakers".

Breathing During Exercise

Do not hold your breath while exercising. Breathe normally as much as possible. Remember, breathing involves the intake and distribution of oxygen, which feeds the working muscles.

Rest Periods

Once you start your exercise program, you should continue through to the end. Do not break off halfway through and then restart at the same place later on without going through the warm-up stage again.

The rest period required between strength training exercises may vary from person to person. This will depend mostly on your level of fitness and the program you have chosen. Rest between exercises by all means. Most people manage with half minute to one-minute rest periods.

Aerobic Fitness

The largest amount of oxygen that you can use per minute during exercise is called your **maximum oxygen uptake** (MVO₂). This is often referred to as your **aerobic capacity**.

The effort that you can exert over a prolonged period of time is limited by your ability to deliver oxygen to the working muscles. Regular vigorous exercise produces a training effect that can 30%. An increased MVO₂ indicates an increased ability of the heart to pump blood, of the lungs to ventilate oxygen and of the muscles to take up oxygen.

Anaerobic Training

This means “without oxygen” and is the output of energy when the oxygen supply is insufficient to meet the body’s long-term energy demands. (For example, 100-meter sprint).

The Training Threshold

This is the minimum level of exercise, which is required to produce significant improvements in any physical fitness parameter.

Progression

As you become fitter, a higher intensity of exercise is required to create an overload and therefore provides continued improvement.

Overload

This is where you exercise at a level above that which can be carried out comfortably. The intensity, duration and frequency of exercise should be above the training threshold and should be gradually increased as the body adapts to the increasing demands. As your fitness level improves, so the training threshold should be raised. Working through your program and gradually increasing the overload factor is important.

Specificity

Different forms of exercise produce different results. The type of exercise that is carried out is specific both to the muscle groups being used and to the energy source involved. There is little transfer of the effects of exercise, e.g. from strength training to cardiovascular fitness. That is why it is important to have an exercise program tailored to your specific needs.

Reversibility

If you stop exercising or do not do your program often enough, you will lose the benefits you have gained. Regular workouts are the key to success.

Warm Up

Every exercise program should start with a warm up where the body is prepared for the effort to come. It should be gentle and preferably use the Stretching should be included in both your warm up and cool down, and should be performed after 3~5 minutes of low intensity aerobic activity or callisthenic type exercise.

Warm Down or Cool Down

This involves a gradual decrease in the intensity of the exercise session. Following exercise, a large supply of blood remains in the working muscles. If it is not returned promptly to the central circulation, pooling of blood may occur in the muscles.

Heart Rate

As you exercise, so the rate at which your heart beat also increases. This is often used as a measure of the required intensity of exercise. You need to exercise hard enough to condition your circulatory system, and increase your heart rate, but not enough to strain your heart.

Your initial level of fitness is important in developing an exercise program for you. If you are starting off, you can get a good training effect with a heart rate of 110-120 beats per minute (BPM). If you are fitter, you will need a higher threshold of stimulation.

To begin with, you should exercise at a level that elevates your heart rate to about 65 to 70% of your maximum heart rate. If you find this is too easy, you may want to increase it, but it is better to lean on the conservative side.

As a rule of thumb, the maximum heart rate is 220 BPM minus your age. As you increase in age, so your heart, like other muscles, loses some of its efficiency. Some of its nature loss is won back as fitness improves.

The following table is a guide for those who are “starting fitness”.

Age	25	30	35	40	45	50	55	60	65
Target Heart Rate									
10 Second									
Count	23	22	22	21	20	19	19	18	18
Beats per									
Minute	138	132	132	126	120	114	114	108	108

Pulse Count

The pulse count (on your wrist or carotid artery in the neck, taken with two index fingers) is done for ten seconds, taken a few seconds after you stop exercising. This is for two reasons: (a) 10 seconds is long enough for accuracy, (b) the pulse count is to approximate your BMP rate at the time you are exercising. Since heart rate slows as you recover, a longer count isn't as accurate.

The target is not a magic number, but a general guide. If you are above average fitness, you may work quite comfortably a little above that suggested for your age group.

The following table is a guide to those who are keeping fit. Here we are working at about 80% of maximum.

Age	25	30	35	40	45	50	55	60	65
Target Heart Rate 10 Second Count	26	26	25	24	23	22	22	21	20
Beats per Minute	156	156	150	144	138	132	132	126	120

Don't push yourself too hard to reach the figures on this table. It can be very uncomfortable if you overdo it. Let it happen naturally as you work through your program. Remember, the target is a guide, not a rule, a little above or below is just fine.

Two final comments: (1) don't be concerned with day to day variations in your pulse rate, being under pressure or not enough sleep can affect it; (2) your pulse rate is a guide, don't become a slave to it.

Endurance Circuit Training

Cardiovascular endurance, muscle strength, flexibility and coordination are all necessary for maximum fitness. The principle behind circuit training is to give a person all the essentials at one time by going through your exercise program moving as fast as possible between each exercise. This increases the heart rate and sustains it, which circuit training effect until you have reached an advantaged program stage.

Periodization

This is the term used to vary your exercise program for both physiological and psychological benefits. In your overall program, you should vary the workload, frequency and intensity. The body responds better to variety and so do you. In addition, when you feel yourself getting "stale", bring in periods of lighter exercise to allow the body to recuperate and restore its reserves. You will enjoy your program more and feel better for it.

Muscle Soreness

For the first week or so, this may be the only indication you have that you are on exercise program. This, of course, does depend on your overall fitness level. A confirmation that you are on the correct program is a very slight soreness in most major muscle groups. This is quite normal and will disappear in a matter of days.

If you experience major discomfort, you may be on a program that is too advanced or you have increased your program too rapidly.

If you experience PAIN during or after exercise, your body is telling you something. Stop exercising and consult your doctor.

SETTING UP YOUR ROWER

Unfolding

Warning : To avoid serious injury, keep fingers/hands/feet away from the folding hinge when unfolding and folding the Rower.

1. Step on the PIVOT LOCK BAR HANDLE with one hand supporting the ALUMINUM BEAM.



2. Slightly put the ALUMINUM BEAM down on the ground.
3. Lift up the ALUMINUM BEAM by pulling up the PIVOT HANDLE until "CLICK" sound is heard.
4. Ensure the PIVOT LOCK BAR HANDLE at the correct position.

Folding

1. Hold the PIVOT HANDLE with right hand and raise up the ALUMINUM BEAM.

2. Push down the PIVOT LOCK BAR HANDLE with left hand to release the folding hinge and slowly let the TRANSPORTATION WHEELS reach the ground.



3. Pull the ALUMINUM BEAM up to the folding position until "CLICK" sound is heard.
4. Ensure the PIVOT LOCK BAR HANDLE at the correct position.

Transportation

Your Rower has transportation wheels located at the middle. This enables you easily move the Rower from room to room.



Do not attempt to transport the Rower without the PIVOT LOCK BAR firmly engaged.

IMPORTANT: Clear a workout area 1 x 2.5 Meters before setting-up your Air Magnetic Rower. Ensure the floor is solid and level.

SETTING UP YOUR ROWER

Getting on Safely

Getting on safely is a simple procedure. Just be careful that the SEAT is directly underneath you before sitting down.



1. Straddle the ALUMINUM BEAM .
2. Correctly position the SEAT beneath you.
3. Sit down taking care that the SEAT has not moved.

Heel Rest Adjustment

Slide your feet underneath the FOOT STRAP .



- There are five heel rest settings clearly numbered.
1. Pull the top HEEL REST out of the slot.
 2. Adjust the HEEL REST to your desired position.

Foot Strap Adjustment

The correct position for the FOOT STRAP is across the top of the foot just below the toes. Approximately across the toe pivot joints. Ensure the FOOT STRAP is tight.



Pull the FOOT STRAP tight as shown in the above diagram.

SETTING UP YOUR ROWER

Foot Strap Release

Pull and releasing the FOOT STRAP.



Pull and releasing the FOOT STRAP.

Handle Bar Holder

When you have finished your workout remember to store the HANDLE BAR into the HANDLE BAR HOLDER.

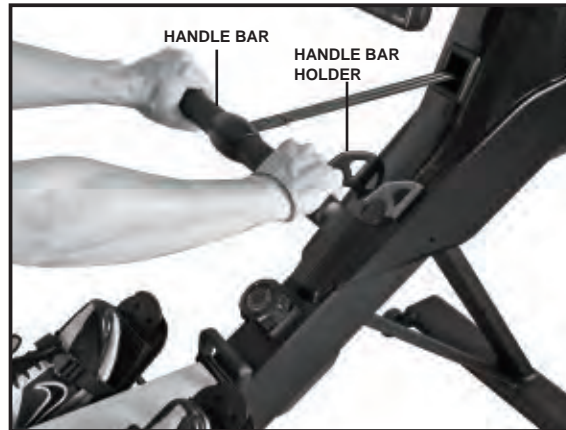

When you have finished your workout place the HANDLE BAR into the HANDLE BAR HOLDER as shown in the diagrams above.

Computer Angle Adjustment

The COMPUTER is designed to rotate and giving you angle adjustment.

NOTE: For safety reasons, whilst exercising avoid the DRIVE STRAP ASSEMBLY touching the COMPUTER .



“Air” is the principal resistance of the rower. On level 1 the resistance is 100% air. As you rotate the resistance knob clockwise you gradually start to introduce the magnetic system in varying degrees according to the setting. On level 16 the resistance is approximately 30% air and 70% magnetic.

CORRECT ROWING GUIDE

Over Reaching

INCORRECT

The body stretches too far forward. The shins may be past vertical. The head and shoulders tend to drop towards the feet. The body is in a weak position for the stroke.



SOLUTION

The shins are vertical. The body is pressed up to the legs. The arms are fully extended and relaxed, body tilted slightly forward. This position should feel comfortable.

Rowing with Arms Bent

INCORRECT

The user starts the stroke by pulling with the arms rather than pushing with the legs.



SOLUTION

The user starts the stroke by pushing the legs and bracing the back with the arms fully extended and relaxed.

Bent Wrists

INCORRECT

The user bends their wrists at any time through the stroke.



SOLUTION

Always row with flat wrists through the entire stroke.

CORRECT ROWING GUIDE

Pulling the Body to the Handle

INCORRECT

At the finish, the user, instead of pulling the handle to the body, pulls themselves forward to the handle.



CORRECT

At the finish the user leans back slightly, holds the legs down and draws the handle to the body using the upper body as a firm platform.

Flying Elbows

INCORRECT

The users elbows are sticking out from the body at the finish and the handle is at chest level.



CORRECT

Draw the handle to the body. The wrists are flat and the elbows pass close to the body. Elbows extend behind the body as the handle is drawn to the waist.

Locking the Knees

INCORRECT

At the end of the stroke the user locks the knees making the legs straight.



CORRECT

Always keep the legs slightly bend in the fully extended position..do not lock the knees.

STRETCHING

Stretching should be included in both your warm up and cool down, and should be performed after 3-5 minutes of low intensity aerobic activity or calisthenic type exercise. Movements should be performed slowly and smoothly, with no bouncing or jerking. Move into the stretch until slight tension, not pain, is felt in the muscle and hold for 20-30 seconds. Breathing should be slow, rhythmic and under control, making sure never to hold your breath.



1. Quadriceps Stretch

Reach behind body with one hand, grasp top of foot and pull heel toward buttocks while maintaining an erect and upright posture. Hold for 20-30 seconds and release. Repeat for opposite leg.



2. Calf, Achilles Stretch

Keeping back leg straight and foot flat on floor with toes pointed straight ahead, move hips forward by bending knee on the front leg. Hold for 20-30 seconds and release. Repeat for opposite leg.



3. Back Stretch

With arms extended and hips directly over feet, lower upper body below hand level by bending at the knees. Hold for 20-30 seconds and release.



4. Rear Upper Arm Stretch

Grasp elbow and pull hand toward midline of the body while maintaining an erect and upright posture. Hold for 20-30 seconds. Repeat for opposite leg.



5. Hamstring, Lower Back Stretch

Holding thigh against upper body, extend leg toward ceiling. Hold for 20-30 seconds. Repeat for opposite leg.



6. Buttocks, Hips, Abdominal Stretch

While keeping both shoulders in contact with the ground, gently pull knee toward the ground. Hold for 20-30 seconds and release. Repeat for opposite side.



7. Inner Thigh Stretch

With soles of feet together, lean forward from the waist while applying downward pressure to the inside of the knees. Hold for 20-30 seconds and release.



8. Chest, Shoulder, Upper Arm Stretch

Move buttocks forward away from arms while keeping arms extended back and palms on ground. Hold for 20-30 seconds and release.

Wireless Heart Rate display issues / diagnosis checklist.

Problem: Wireless Heart Rate Erratic, incorrect or not working.

Caution! You should not use Heart Rate Control programs (If your machine is equipped) unless you are receiving a steady Heart Rate reading.

The first couple of things to check is the Heart Rate Belt itself:

1. You may need a your battery replaced (Note: Some Heart Rate Belts do not have a user changeable battery, you may need to purchase a replacement belt). Belts transmit by radio so as the battery goes dead , the transmission range can be reduced.
2. On machines where the user can move far aware from the display, a Heart Rate Belt with a longer transmission range is required (like the Polar T34).
3. The belt you have may not be Polar compatible. While most belts made use what is considered the industry standard, some do not. Please consult your belt manufacture and verify that your Heart Rate Belt transmits on the 5kHz frequency.

If you are sure these are not the cause please follow this checklist:

Unusually high, low or random numbers in the heart rate display indicate a problem and is likely being caused by interference.

Check for these possible causes:

1. The receiver that picks up your heart rate is very sensitive, you can try rotating the entire machine or relocate the machine to another part of the room.
2. Some people have problems with the transmitter picking up a signal from their skin. Try dampening the electrodes first. You can also try using an electrode gel such as SignaGel which can be purchase online or at you local medical supply store.
3. Televisions, Microwaves and other Small Appliances.
4. Fluorescent/LED lights. Or any lighting that uses a ballast.
5. Invisible or Perimeter Electric Fences.
6. Some household security systems and specialized types of alarms and monitoring such as a system that would detect high water, etc...
7. Another Individual wearing a transmitter within 3' of your machine's console.

If you continue to experience problems contact your dealer or Bodycraft at info@bodycraft or 1-800-990-5556.

BODYCRAFT

400 *COMMERCIAL ROWING MACHINE*



ASSEMBLY  INSTRUCTIONS



WWW.BODYCRAFT.COM



800-990-5556



SERVICE@BODYCRAFT.COM

VR400 ASSEMBLY INSTRUCTIONS

Introduction

This product has been designed and manufactured to meet the needs and requirements of domestic use.

Please carefully read the instructions prior to assembly and first use. Be sure to keep the instructions for reference and/or maintenance.

If you have any further questions, please contact us. We wish you lots of success and fun while training.

Table of Contents

Introduction	page 15
Table of Contents	page 15
Check List	page 15
Assembly Steps 1~6	page 16
Assembly Steps 7~10	page 17
Detailed Parts List	page 18
Exploded Drawing	page 19

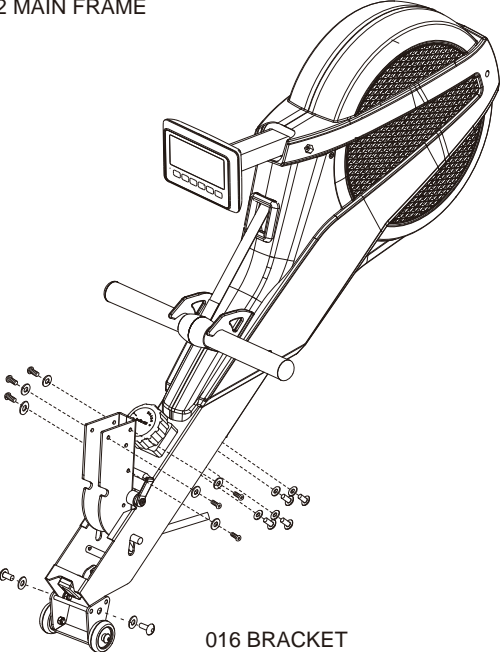
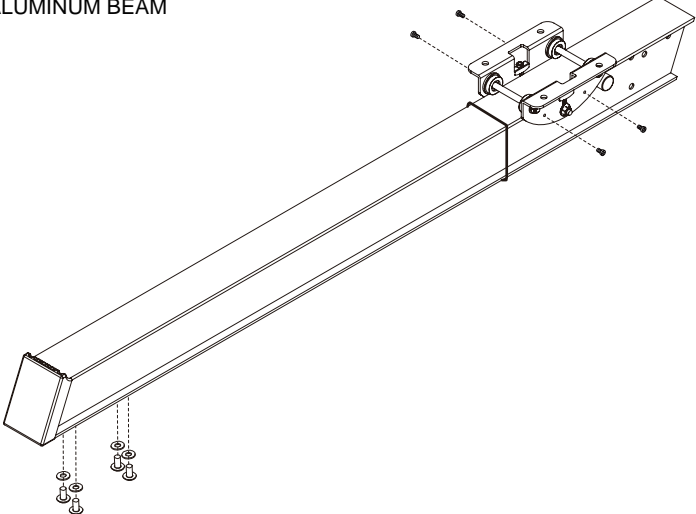
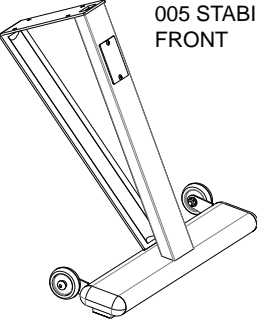
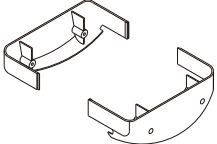
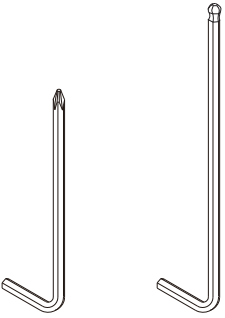
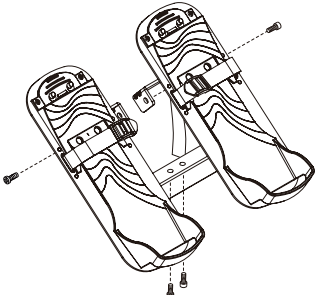
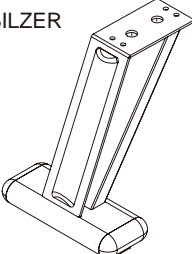
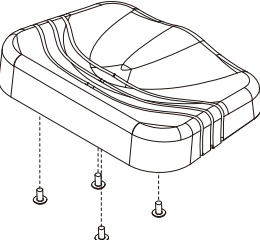
Check List IF ANY OF THESE PARTS ARE MISSING CONTACT YOUR DEALER IMMEDIATELY.			
<p>002 MAIN FRAME</p>  <p>016 BRACKET</p>	<p>001 ALUMINUM BEAM</p> 	<p>005 STABILIZER FRONT</p> 	
<p>117 CARRIAGE COVER</p> 	<p>TOOL</p> 	<p>013 FOOT PEDAL</p> 	<p>006 STABILIZER REAR</p> 
		<p>119 SEAT</p> 	

VR400 ROWER ASSEMBLY INSTRUCTIONS

STEP 1

Clear a 6 X 9 foot working space before unpacking your VR400 Rower.

STEP 2

Open the carton as shown in the diagram below.

NOTE: To protect the Dual Mode Rower while assembling we suggest that you do not remove the protective Packing Material until it is absolutely necessary.

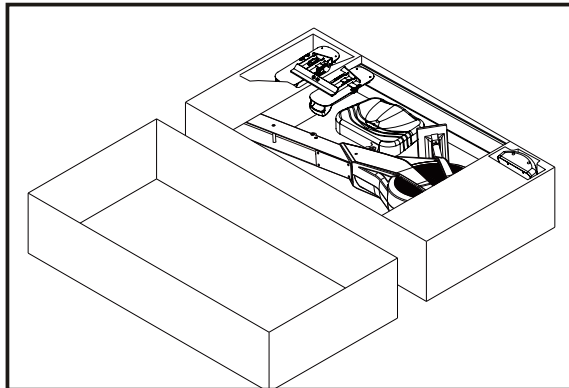

STEP 3

- Place the MAIN FRAME [002] upon the Carton Lid and poly foam as shown in the diagram below.
- Remove 4 x BOLT [319] and 4 x WASHER [414] from MAIN FRAME [002] with the tool provided.
- Connect BATTERY CASE with CABLE[143A]to SENSOR CABLE with BATTERY CABLE[706]
- Assemble the STABILIZER - FRONT [005] and the MAIN FRAME [002] with 4X BOLT [319] and 4 x WASHER [414] .

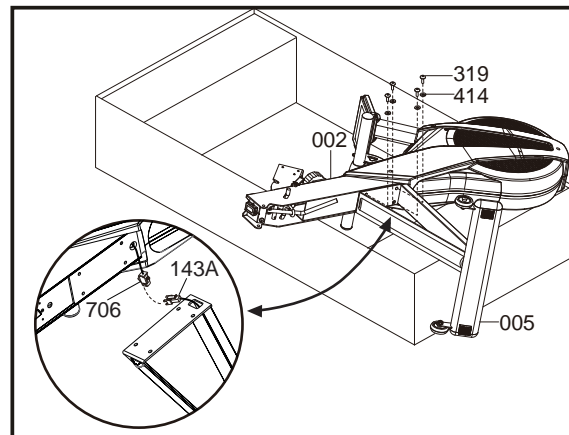

STEP 4

- Attach the WHEEL BRACKET ASSEMBLY to the MAIN - FRAME [002] as shown in the diagram below taking care to WHEEL BRACKET ASSEMBLY around the correct way.
- Remove 2 x BOLT [367] and 2 x WASHER [414] from MAIN FRAME [002] with the tool provided.
- Secure the WHEEL BRACKET ASSEMBLY with 2 x BOLT [367] + 2 x WASHER [414] with the Tools provided and tighten firmly.

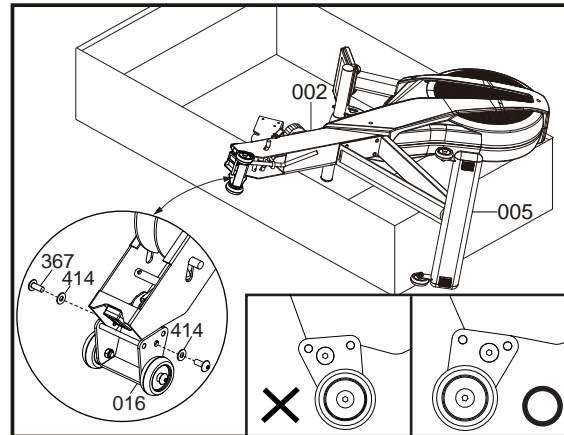

STEP 5

- Remove 4 x BOLT [319] and 4 x WASHER [414] from ALUMINUM BEAM [001] with the tool provided.
- Assemble the STABILIZER - REAR [006] and the ALUMI-NUM BEAM [001] with 4 x BOLT [319] and 4 X WASHER [414] .

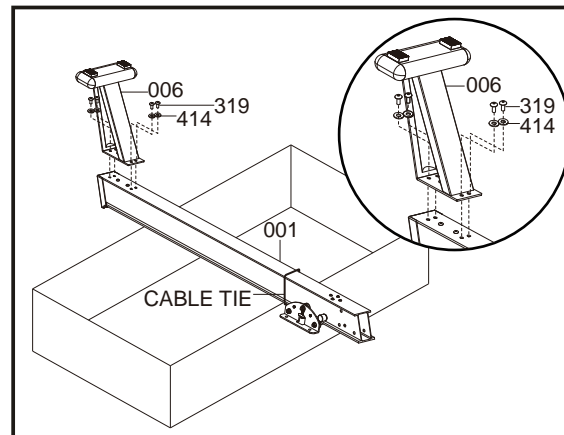

STEP 6

- Remove the partly assembled rower from the carton lid and place it the correct way up as shown in the diagram below.
- Remove the SAFETY STRAP HOLDER .
- Remove 6 x BOLT [319] and 6 x WASHER [414] from PIVOT BRACKET [003] with the tool provided.
- Assemble the ALUMINUM BEAM [001] and the PIVOT BRACKET [003] with 6 x BOLT [319] and 6x WASHER [414]. But note not to tighten the BOLT [319].

NOTE: When assembling the ALUMINUM BEAM [001] with the PIVOT BRACKET [003], make sure the HANDLE GRIP [004] is not touching the PIVOT BRACKET [003] in order to avoid the HANDLE GRIP [004] being scratched by the ALUMINUM BEAM [001].

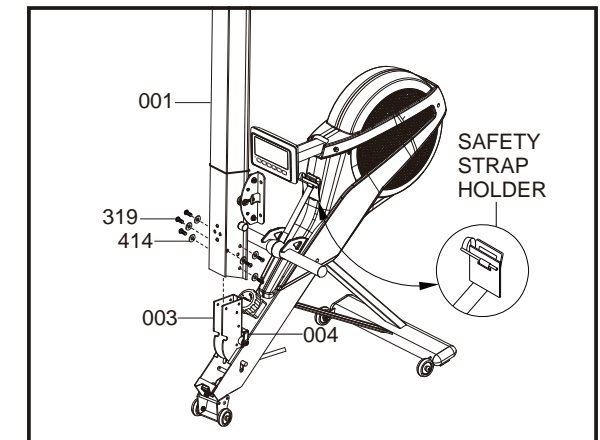

DUAL MODE ROWER ASSEMBLY INSTRUCTIONS

STEP 7

- Remove 4 x BOLT [319] from SEAT [119] with the tool provided.
- Assemble the SEAT [119] and the SEAT CARRIAGE [009] with 4 X BOLT [319] .
- Cut and Remove the ALUMINUM BEAM [001] CABLE TIE

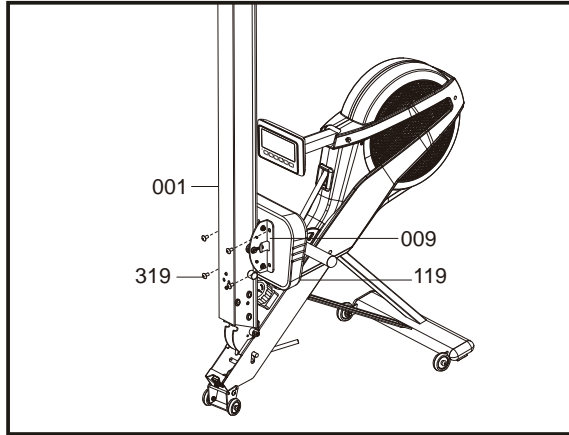

STEP 8

- Remove 4 x BOLT [304] from SEAT CARRIAGE [009] with the tool provided.
- Assemble the CARRIAGE COVER [117] and the SEAT CARRIAGE [009] with 4 X BOLT [304] .

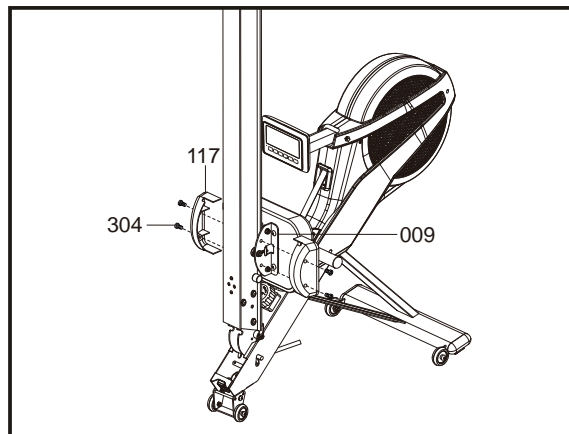

STEP 9

- Assemble the FOOT PEDAL [013] and the ALUMINUM BEAM [001] with 4 X BOLT [367] .Tighten 4 x BOLT [367] and 6 x BOLT [319] you left loose from STEP 5 at this time.

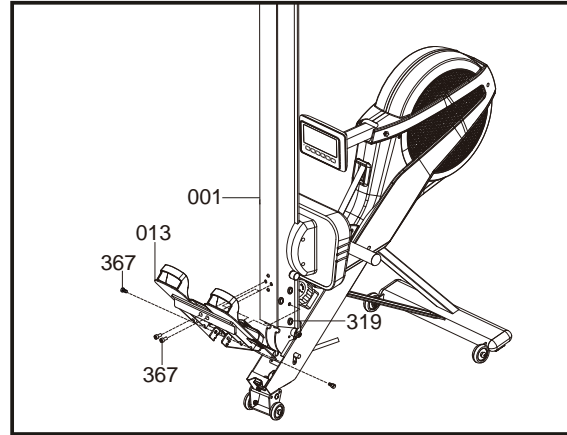

STEP 10

- Remove 2 x SCREW [508] and BATTERY COVER [153] from STABILIZER - FRONT [005] .
- Install 3 AA Batteries as shown [143A].
- Reinstall the BATTERY COVER [153] to the STABILIZER - FRONT [005] with 2 X SCREW [508] .

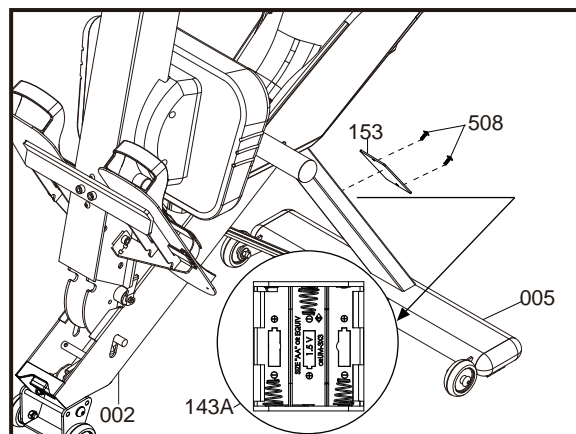

VR400 ROWER PARTS LIST

PART No.	DESCRIPTION	Q'TY	PART No.	DESCRIPTION	Q'TY	PART No.	DESCRIPTION	Q'TY
001	ALUMINUM BEAM	1	120A	STRAP COVER	2	370	BOLT-M8x38mm	2
002	MAIN FRAME	1	122	PLUG	2	370A	BOLT	1
003	PIVOT BRACKET	1	123	FOAM GRIP	2	370B	BOLT-M8x16mm	2
003A	PIVOT HANDLE	1	123A	PIVOT LOCK BAR HANDLE COVER	1	378A	BOLT-3/8"x1/8"	1
004	HANDLE GRIP	1	124	CARRIAGE STOPPER	2	386A	BOLT-M5x10mm	4
005	STABILIZER - FRONT	1	132	STRAP SLOT TRIM	1	390	BOLT-M6x80mm	1
006	STABILIZER - REAR	1	134	POLY " V " DRIVE BELT	1	403	WASHER- \varnothing 10x22x 2T	2
006A	PIVOT LOCK BAR	1	136	CLUTCH ASSEMBLY	1	403A	WASHER- \varnothing 12x16x 1T	1
007	REAR BRACKET	1	139	RETURN SPRING ASSEMBLY	1	412	WASHER- \varnothing 8x12x 1T	6
008	ALI HANDLE BAR	1	140	FLYWHEEL FAN	1	414	WASHER- \varnothing 8x18x 1.5T	32
009	SEAT CARRIAGE	2	142	RESISTANCE ADJUSTER	1	508	SCREW-M4x12mm	2
010	SEAT CARRIAGE - SHAFT	2	143	HEEL REST	2	508A	SCREW-M4x10mm	16
011	ROLLER ADJUSTMENT BOLT	2	143A	BATTERY CASE with CABLE	1	515	SCREW-st 3/42" x 3/4"	10
011A	ROLLER ADJUSTMENT BOLT	2	147	HEEL REST HOLDER	2	529A	SCREW-M3x6L	2
012	ROLLER ADJUSTMENT PLATE	4	149	BUSHING	2	540	SCREW-M4x16mm	8
013	FOOT PEDAL	1	151	SENSOR HOLDER	1	541	SCREW-M4x8mm	2
014	PLATE WASHER	1	152	POST	1	701	COMPUTER CABLE	1
015	COMPUTER ARM	1	153	BATTERY COVER	1	702	SENSOR with CABLE	2
016	BRACKET SET	1	155	TRIM COVER	1	705	COMPUTER CABLE	1
022	BEARING BRACKET - LIFT	1	156	STABILIZER FOOT	4	706	SENSOR CABLE with BATTERY CABLE	1
023	BEARING BRACKET - RIGHT	1	158	CABLE PLUG	2	708A	PIVOT LOCK BAR SPRING	1
027	STRAP HOLDER	2	159	BUSHING	2	709	DRIVE STRAP	1
028A	PIVOT LOCK BAR HANDLE	1	207	NUT-3/8"x26 UNC	4	710	FOOT STRAP	2
030	HANDLE BAR HOLDER RIGHT	1	212	NUT-M6	7	711	CHEST BAND RECEIVER	1
031	HANDLE BAR HOLDER LIFT	1	213	NUT-M8	13	714	COMPUTER with CABLE	1
106	COMPUTER CASE NUT COVER	2	214	NUT-3/8"	1	802	BEARING(6000zz)	2
107	COMPUTER ARM SPACER	2	301A	BOLT-M6x55mm	1	803	BEARING(608zz)	6
110	COVER - HUB	2	304	BOLT-M8x30mm	4			
111A	MAIN COVER RIGHT	1	314A	BOLT-M4x6mm	8			
111B	MAIN COVER LEFT	1	315A	BOLT-M6x25mm	1			
113	WHEEL	2	319	BOLT-M4x16mm	20			
115	STANDARD CAP	4	342	BOLT-M8x30mm	2			
116	ALUMINUM BEAM END CAP	1	349	BOLT-M8x90mm	1			
117	CARRIAGE COVER	2	349A	BOLT-M8x100mm	2			
118	SEAT CARRIAGE ROLLER	4	359B	BOLT-M5x10mm	2			
118A	SPECIAL SEAT ROLLER	2	360	BOLT-M6x10mm	8			
119	SEAT	1	367	BOLT-M8x16mm	6			

VR400 ROWER EXPLODED DRAWING

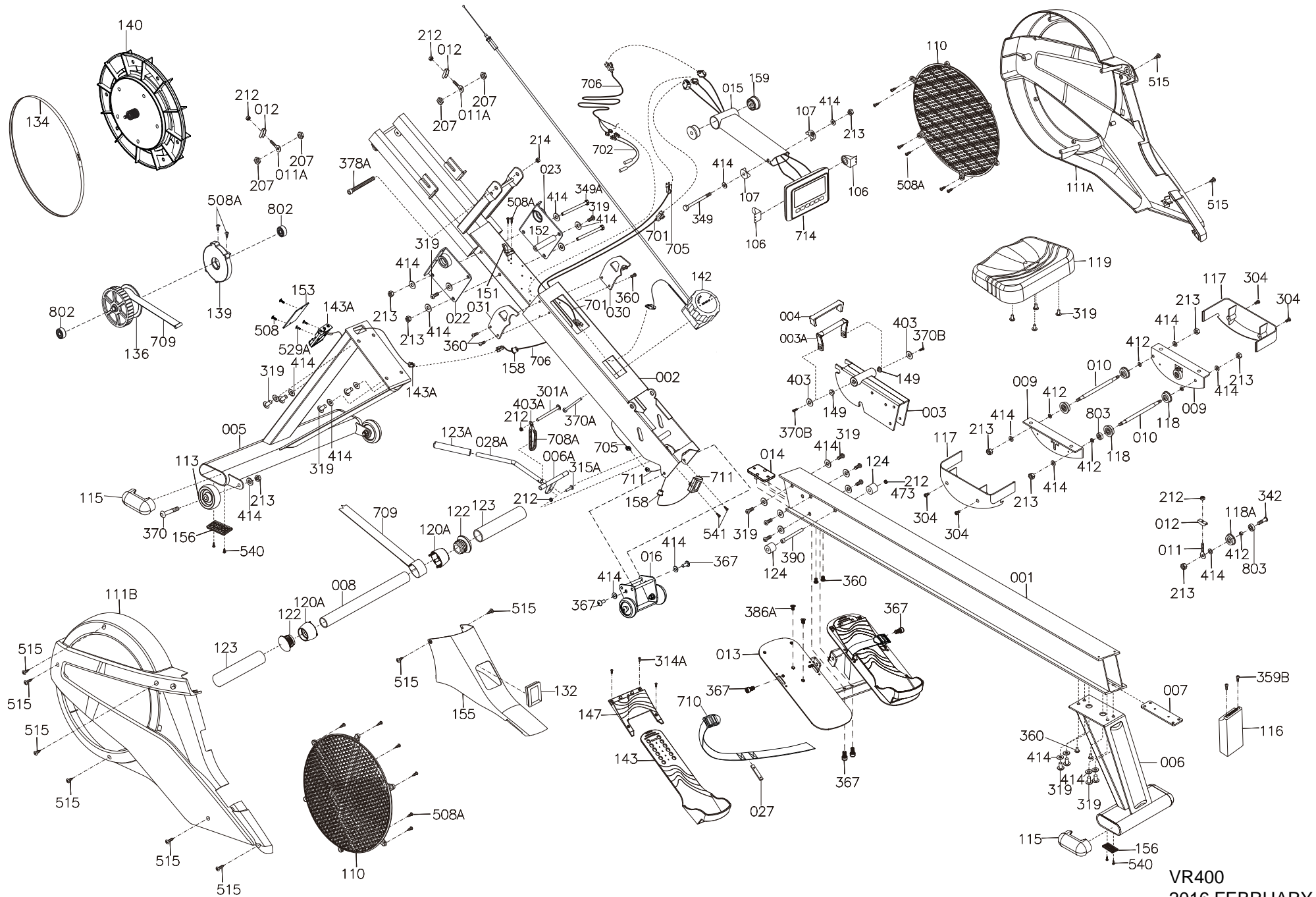

VR400
2016 FEBRUARY

DISPLAY DESCRIPTION

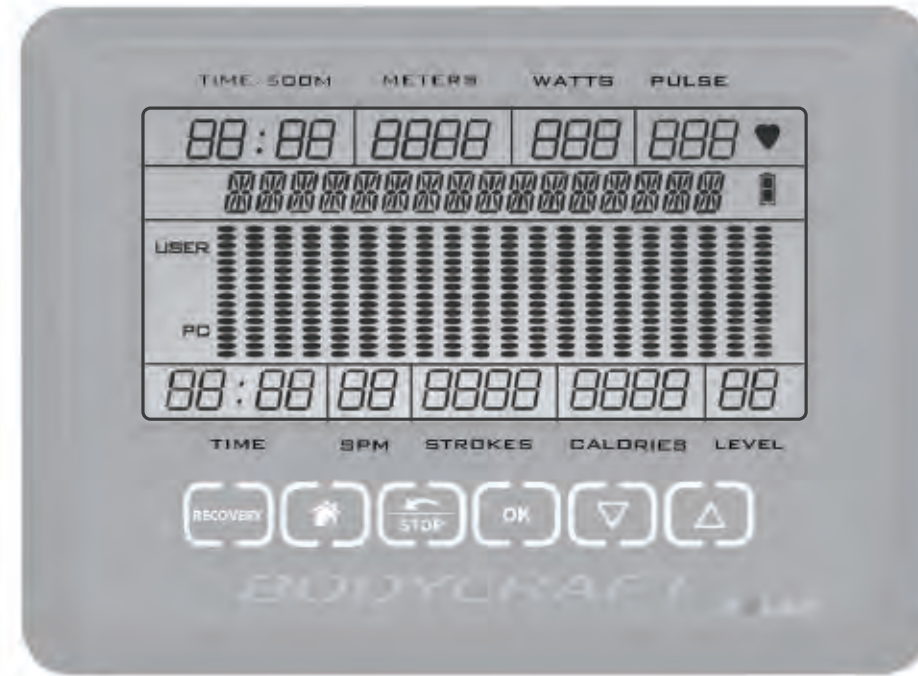

TIME / 500 M: Displays the calculated current pace per 500 Meters. The display changes with every stroke to provide immediate feedback.

METER: Displays calculated distance traveled in Meters. Or, if a distance goal is selected, the display will count down from preset distance to 0.

WATT: Displays the current user power output in watts.

PULSE: Displays the current user Heart Rate. This feature is only available with the optional Telemetry Heart Rate Chest Strap.

TIME: Displays the elapsed time during workout. Or, if a time goal is selected, the display will count down from present time to 0.

SPM: Displays current strokes per minute. The display changes with every stroke to provide immediate feedback.

STROKES: Displays # of strokes completed. The display changes with every stroke to provide immediate feedback.

CALORIES: Displays approximate calorie expenditure. Or, if user preset a calorie goal, this display will count down from preset calorie goal to 0.

LEVEL: Displays the current resistance level. There are 16 resistance levels; 1 levels per LCD row.

KEY FUNCTIONS

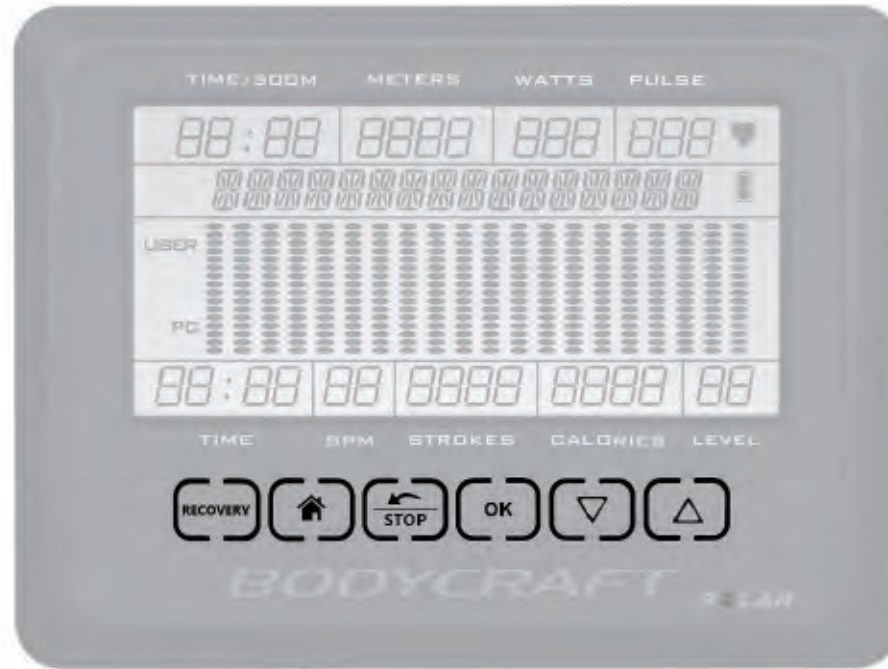

Press this key at the end of the workout to test your fitness level. The computer will analyse your recovery heart rate and provides a score from 0 - 100.
Test requires a valid heart rate signal which is obtained from the Telemetry heart rate chest strap (optional purchase).



Reverse back to main screen during Setup; Pause; Workout Summary and Engineering mode.



Press (BACK) button during program selection or Setup, it will go back to last setting.
Press (STOP) button during program execution to end the program and enter summary review.
Press and hold (STOP) button for 2 seconds to reset the display and return to main screen.



Confirm setting or selection.



Change program or value



Change program or value

POWERING ON YOUR ROWER

Once your rower is fully assembled then you are ready to power on your rower for the first time. This computer requires 3 x AA 1.5V batteries. To prevent damage or loose memory of the computer, it is recommended that you replace the batteries at least every 6 months. Battery life is approximately three to six months under normal usage.

Note: There is a battery indicator built in on the display. When the battery symbol is flashing on the display, it is time to replace the battery.

On the initial power up, all the LCD segments on the display will briefly light up for about 2 seconds, then main screen will appear with message scrolling – SELECT PROGRAM OR BEGIN ROWING.

This computer is built with auto power save mode. When there is no activities detected for 4 minutes, the computer display will turn off automatically to save power. To wake up the display, simply press any key or row.

OPERATION

Quick Start:

The quickest way to start a workout is to simply start rowing. This will initiate the Manual mode. In Quick Start mode, the Time will count up from zero, and display a flat profile. All workout data will start accumulating and the workload may be adjusted manually by turn the resistance knob from level 1 – 16. The dot matrix display will show only the bottom row lit at first. As you increase the workload, more rows will light up indicating a harder workout. There are 16 levels of resistance. Each of the 16 rows represents 1 resistance level. The handlebar will get harder to pull as the rows increase. The dot matrix has 20 columns of lights and each column represents a distance traveled of 250 Meters (at default). At the end of the 20th column (or 5000 Meters) the display will wrap around and start at the first column.

Standard Operation:

Main Screen → (UP ▲ / DOWN ▼) for Program Selection → User Setting → Goal Selection → Start Program → End Program → Review summary.

- In the main screen, press (UP ▲ / DOWN ▼) button to toggle through a list of programs. When the desired program appears, press (OK) to confirm the program selection.
 - Once a program is selected, the next step is to select a User. (See User Mode section for how to set up a user profile.) If User 0 is selected, all user data (ie. age, weight...) will appear one at a time for adjusting. Press (UP ▲ / DOWN ▼) button to adjust the value and (OK) to confirm each setting. If User 1-4 profile is set up and selected, then it will bypass the user data setting and go to Goal options.
-

OPERATION

- There are TIME, DISTANCE & CALORIES 3 goal options to choose as the program goal. Once a goal is selected, the program setting is now completed and program will begin.
- This computer is equipped with the Program Quick Start function. You may row at anytime during program setting to bypass the remaining program settings (use default values) and jump start the program right away.

Pause Function:

The computer comes with a Pause function for a quick break after program has started. When User stops rowing, the computer will enter Pause mode with “PAUSED” display and stop data accumulating for a period of 4 minutes. To resume, simply row again. If the computer is paused more than 4 minutes, it will reset and turn off screen to save power.

Review Summary:

When the program goal is reached, the program timer will switch to count up instead. When (STOP) button is pressed during the program, the program will end and the workout summary will be displayed for review. If USER1-4 was selected before the workout, the options of saving the workout summary into USER's workout history will appear during this time.

User Mode:

There are 5 user modes, Users 0-4. User 0 is the guest user which means any data entered or collected will not be saved after workout. Users 1-4 contain memory banks to remembered personal data as well as workout history. To set up User's profile, select “USER DATA” during program selection and press (OK) button to confirm. Inside “USER DATA”, there are 3 options to select from: “USER EDIT” for editing user profile; “USER REVIEW” for workout history review and “USER DELETE” to delete user profile or workout history.

MANUAL MODE

As the name implies, in Manual mode, you control the workload. You can simply start rowing as a Quick Start, or press (UP ▲/DOWN ▼) in main screen to select “MANUAL” and press (OK) button to confirm. Select a User 1-4 or 0 as the guest user to start. The appropriate settings will be prompted on the display following the User selection for the adjustment. Once setup is completed, the program will begin. You may turn resistance knob to adjust the resistance level during program.

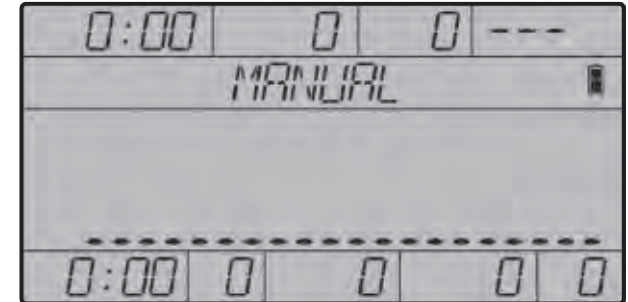

RACE MODE

Press (UP ▲/DOWN ▼) in main screen to select “RACE” and press (OK) button to confirm.

There are 5 preset races to race against.

You can also pick USER 1-4 to race against if there is a saved user workout history inside.

If there is no saved data inside a User, the display will prompt with “NO USER DATA” and return back to 1st race selection.

Race details:

- | | |
|--------------------|------------------------------------|
| ○ Individual | 500m (Default time goal is 3:00) |
| ○ Beginner Track | 1000m (Default time goal is 6:00) |
| ○ Olympic Track | 2000m (Default time goal is 12:00) |
| ○ Long Track | 5000m (Default time goal is 30:00) |
| ○ Oxford Boat Race | 6779m (Default time goal is 40:00) |
| ○ USER 1-4 | User average time/500m |

The dot matrix will display both User and PC's progress during program. When the target distance is reached, the race will end and winner will be displayed.

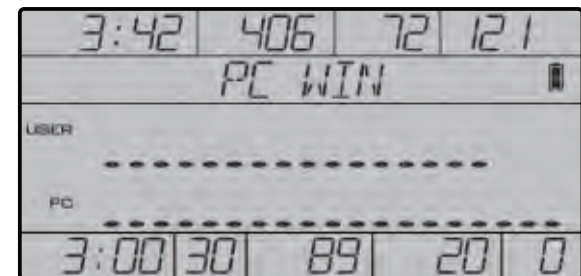
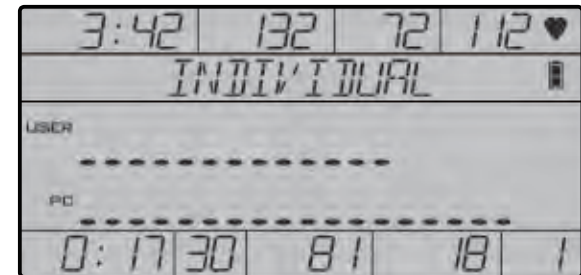
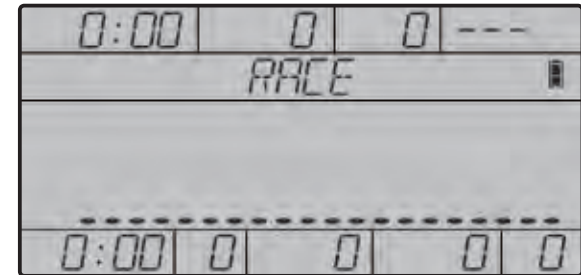

USER DATA MODE

User Data mode is designed to store all your personal information so that you can get into your workout quickly without going through all the settings every time. It also track your workout history if you choose to do so. In main screen, press (UP ▲/DOWN ▼) to select “USER DATA” and press (OK) button to confirm. There are 4 User spaces to store your personal data. You have the options of “USER EDIT” to edit your personal profile; “USER REVIEW” to review your workout history and “USER DELETE” to delete either User Profile or Workout History.

The default User IDs are USER 1-4; however once you input your name into a User #, the User ID will switch to display the initial of your name you entered. Press (UP ▲/DOWN ▼) button to adjust and (OK) to confirm the adjustment. (To end a Name entry, press and hold (OK) button for a few seconds.) For time saving and better workout experience, it is recommended that you set up your user profile before the workout.

RECOVERY MODE

Press (RECOVERY) button at the end of workout, all display will stop except the TIME display. The TIME will start counting down from 1:00. The screen will display your heart rate recovery status. When the time counts down to 0, it will analyze the heart rate recovery rate and present a score 0 - 100. The score is an indication of your fitness level.

90-100	80-89	70-79	60-69	50-59
SUPER FIT	EXTREMELY FIT	VERY FIT	GOOD FIT	AVERAGE FIT
40-49	30-39	20-29	10-19	0-9
FAIR FIT	POOR FIT	UNFIT	VERY UNFIT	EXTREMELY UNFIT

Note: The function will only work if there is a valid heart rate signal during the time the RECOVERY button is pressed. An optional heart rate strap must be worn to get the heart rate signal.

UNITS OF MEASUREMENT SETTING

Step 1: In the main screen, press (UP ▲/DOWN ▼) buttons at the same time for a couple of seconds to enter “Engineering mode”. The screen will show “ENGINEERING MODE”.

Step 2: Press (UP ▲/DOWN ▼) button to get to “UNITS SETTING” and press (OK) button to confirm. The default setting of “ENGLISH” system will be displayed.

Step 3: Press (UP ▲/DOWN ▼) button to change it to “METRIC” system and (OK) button to confirm the setting and a message of “UNITS CONFIRMED” will appear. Press (HOME) button to go back to main screen and finish the setting.

CONGRATULATIONS! And THANK YOU for selecting the BODYCRAFT VR400 ROWER! Your choice reflects a wise investment in you and your family's health and wellness. We hope you use it for many healthy years!

For your safety and benefit, please read this entire manual. Please keep the manual in a convenient place for quick reference when needed. Bodycraft offers a complete array of high quality fitness equipment. Please refer to our web site at www.bodycraft.com to view more ways to enhance your lifestyle.

Your Bodycraft **VR400 ROWER** has all the quality and design elements to make your workout extremely efficient and comfortable. Your new **VR400 ROWER** is a serious cardio fitness machine that will keep you motivated, challenged and within reach of your fitness goals. The Bodycraft **VR400 ROWER** will provide an efficient, low impact cardiovascular workout that will help improve energy levels and your quality of life. Cardiovascular training is vital for all ages and the Bodycraft **VR400 ROWER** will provide an effective workout, producing results that will encourage you to reach your fitness goals and maintain the body you have always wanted. Spending 15 to 30 minutes a day, three times a week is all you need to start seeing the benefits of a regular exercise program.

As a premium exercise equipment manufacturer we are committed to your complete satisfaction. If you have questions, suggestions or find missing or damaged parts, we guarantee your complete satisfaction through our authorized dealer network or by contacting us directly. Please call your local dealer or Bodycraft.

Phone: 800-990-5556 9am - 5pm EST **Email:** service@bodycraft.com

Recreation Supply, Inc.
7699 Green Meadows Dr.
Lewis Center, OH 43035

Purchaser's Reference Information:

IT IS IMPERATIVE THAT YOU FILL IN THE FOLLOWING INFORMATION AND REFER TO IT SHOULD THE NEED FOR SERVICE ARISE.

Product Name: **VR400 ROWER**

Serial Number: **RW** _____

Proof of purchase must be supplied to validate warranty and the product must have been registered with Bodycraft via online at www.bodycraft.com or by calling 800-990-5556 or 740-965-2442 M-F 9 a.m-5 p.m EST.

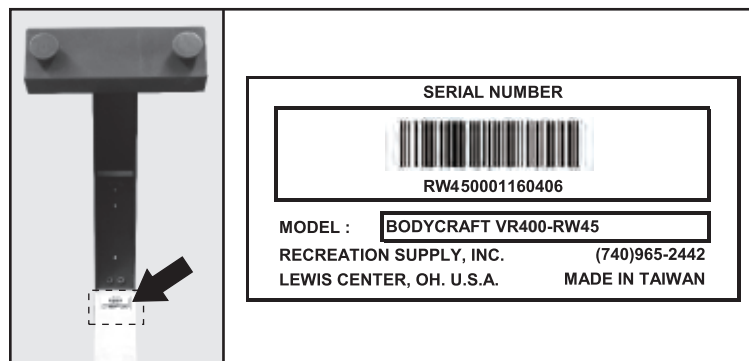

Bodycraft VR400 Rower Warranty

BODYCRAFT warrants its products to be free of defects in material and workmanship for the time stated below to the original purchaser.

This warranty is valid only in accordance with the following conditions:

- The warranty begins on the original date of purchase at retail and ends when the original owner disposes of it, either through sale, gift, or otherwise.
- This warranty is available only for purchases made within the USA and Canada, and currently residing in the USA or Canada.*
- In order for the warranty to be valid for the terms listed below, the product must be registered with BodyCraft within 30 days of purchase.
- The warranty is not transferable and does not cover normal maintenance.
- This warranty applies to Residential and Light Commercial use only and is void when used in a Full Commercial environment.
- This warranty does not cover damage resulting from accident, misuse, water, tampering, unreasonable use, unauthorized repairs, improper repairs, alterations or normal wear and tear.
- If the item exhibits such a defect, BODYCRAFT will, at its option, repair or replace it without cost for parts. Shipping and handling charges may apply. (BODYCRAFT may request a return of the part(s) or photographic evidence of the damaged part(s) prior to replacement at the owners expense).
- Proof of purchase must be supplied to validate warranty and the product must have been registered with BodyCraft via the included warranty card or online at www.bodycraft.com.
- This warranty is in lieu of all warranties, expressed or implied, and/or all other obligations or liabilities on our part and we neither assume nor authorize any person to assume for us any other obligation or liability in connection with the sale of the BodyCraft VR400 Pro Rower. Under no circumstances shall we be liable by virtue of this warranty or otherwise for damage to any person or property whatsoever for any special, indirect, incidental, secondary or consequential damage of any nature whatsoever arising out of the use or inability to use the BodyCraft VR400 Pro Rower.
- **Residential: Frame:** Lifetime, Parts: 7 Years, 2 Years Labor.
- **Commercial (up to 5 hours a day) Frame:** 10 Years, Parts: 3 years, Labor: 1 Year

* If you do not reside within the USA or Canada, please contact your local BODYCRAFT distributor for details specific to you.

** 5 hours or less of daily use.