

INTEGRITY X CONSOLE

Integrity INTSX, INTDX, and Club Series Treadmills

Operation Manual



CORPORATE HEADQUARTERS

Columbia Centre III, 9525 West Bryn Mawr Avenue, Rosemont, Illinois 60018 • U.S.A.

847.288.3300 • FAX: 847.288.3703

Service phone number: 800.351.3737 (toll-free within U.S.A., Canada)

Global Website: www.lifefitness.com

INTERNATIONAL OFFICES

AMERICAS

North America Life Fitness, Inc.

Columbia Centre III
9525 West Bryn Mawr Avenue
Rosemont, IL 60018 U.S.A
Telephone: (847) 288 3300
Fax: (847) 288 3703
Service Email:
customersupport@lifefitness.com
Service Website: www.lifefitness.com/parts
Sales/Marketing Email:
consumerproducts@lifefitness.com
Operating Hours: 7:00 am-6:00 pm (CST)

Brazil Life Fitness Brasil

Av Reboucas 2315
São Paulo, SP 05401-300
BRAZIL
SAC: 0800 773 8282
Telephone: +55 (11) 3095 5200
Fax: +55 (11) 3095 5201
Service Email: suporte@lifefitness.com.br
Sales/Marketing Email:
lifefitness@lifefitness.com.br
Service Operating Hours:
9:00 - 17:00 (BRT) (Monday-Friday)
Store Operating Hours:
9:00 -20:00 (BRT) (Monday-Friday)
10:00 - 16:00 (BRT) (Saturday)

Latin America & Caribbean* Life Fitness Inc.

Columbia Centre III
9525 West Bryn Mawr Avenue
Rosemont, IL 60018 U.S.A
Telephone: (847) 288 3300
Fax: (847) 288 3703
Service Email:
customersupport@lifefitness.com
Sales/Marketing Email:
consumerproducts@lifefitness.com
Operating Hours: 7:00am-6:00pm (CST)

EUROPE, MIDDLE EAST, & AFRICA (EMEA)

Netherlands & Luxemburg Life Fitness Atlantic BV

Bijdorpplein 25-31
2992 LB Barendrecht
THE NETHERLANDS
Telephone: (+31) 180 646 666
Fax: (+31) 180 646 699
Service Email:
service.benelux@lifefitness.com
Sales/Marketing Email:
marketing.benelux@lifefitness.com
Operating Hours: 9.00h-17.00h (CET)

United Kingdom & Ireland Life Fitness UK LTD

Queen Adelaide
Ely, Cambs, CB7 4UB
Telephone: General Office (+44)
1353.666017
Customer Support (+44) 1353.665507
Fax: (+44) 1353.666018
Service Email: uk.support@lifefitness.com
Sales/Marketing Email: life@lifefitness.com
Operating Hours:
General Office: 9.00am - 5.00pm (GMT)
Customer Support: 8.30am - 5.00pm (GMT)

Germany & Switzerland Life Fitness Europe GMBH

Siemensstraße 3
85716 Unterschleißheim
GERMANY
Telephone: (+49) 89.31 77 51.0 (Germany)
(+41) 0848 000 901 (Switzerland)
Fax: (+49) 89.31 77 51.99 (Germany)
(+41) 043 818 07 20 (Switzerland)
Service Email:
kundendienst@lifefitness.com
Sales/Marketing Email:
kundenberatung@lifefitness.com
Operating Hours: 08.30 -16.30h (CET)

Austria Life Fitness Austria

Vertriebs G.m.b.H.
Dückerstraße 7-9/3/36
1220 Vienna
AUSTRIA
Telephone: (+43) 1.61.57.198
Fax: (+43) 1.61.57.198.20
Service Email: kundendienst@lifefitness.com
Marketing/Sales Email:
kundenberatung@lifefitness.com
Operating Hours: 08:30-16.30.h (MEZ)

Spain Life Fitness IBERIA

C/Frederic Mompou 5,1ª^a
08960 Sant Just Desvern Barcelona
SPAIN
Telephone: (+34) 93.672.4660
Fax: (+34) 93.672.4670
Service Email: servicio.tecnico@lifefitness.com
Sales/Marketing Email:
info.iberia@lifefitness.com
Operating Hours:
9.00h-18.00h (Monday-Thursday)
8.30h-15.00h (Friday)

Belgium Life Fitness Benelux NV

Parc Industriel de Petit-Rechain
4800 Verviers
BELGIUM
Telephone: (+32) 87 300 942
Fax: (+32) 87 300 943
Service Email:
service.benelux@lifefitness.com
Sales/Marketing Email:
marketing.benelux@lifefitness.com
Operating Hours: 9.00h -17.00h (CET)

All Other EMEA Countries & Distributor Business C-EMEA*

Bijdorpplein 25-31
2992 LB Barendrecht
THE NETHERLANDS
Telephone: (+31) 180 646 644
Fax: (+31) 180 646 699
Service Email:
service.db.cemea@lifefitness.com
Sales/Marketing Email:
marketing.db.cemea@lifefitness.com
Operating Hours: 9.00h-17.00h (CET)

ASIA PACIFIC (AP)

Japan Life Fitness Japan

Japan Nippon Brunswick Bldg., #8F
5-27-7 Sendagaya
Shibuya-Ku, Tokyo
Japan 151-0051
Telephone: (+81) 3.3359.4309
Fax: (+81) 3.3359.4307
Service Email: service@lifefitnessjapan.com
Sales/Marketing Email:
sales@lifefitnessjapan.com
Operating Hours: 9.00h-17.00h (JAPAN)

Hong Kong Life Fitness Asia Pacific LTD

32/F, Global Trade Square
21 Wong Chuk Hang Road
HONG KONG
Telephone: (+852) 2575.6262
Fax: (+852) 2575.6894
Service Email:
HongKongEnquiry@lifefitness.com
Sales/Marketing Email:
Marketing.HK.Asia@lifefitness.com
Operating Hours: 9.00h-17.00h
Service Operating Hours: 9.00h-18.00h

All Other Asia Pacific countries & distributor business Asia Pacific* Life Fitness Asia Pacific LTD

32/F, Global Trade Square
21 Wong Chuk Hang Road
HONG KONG
Telephone: (+852) 2575.6262
Fax: (+852) 2575.6894
Service Email:
HongKongEnquiry@lifefitness.com
Sales/Marketing Email:
Marketing.HK.Asia@lifefitness.com
Operating Hours: 9.00h-17.00h
Service Operating Hours: 9.00h-18.00h

* Also check www.lifefitness.com for local representation or distributor/dealer.

Table of Contents

Important Safety Instructions	5
Integrity X Console Overview	7
Entertainment Rack Overview	8
Home Screen Overview	9
Log In	10
Log In - Welcome Screen	11
Select Workout	12
Heart Rate Workouts	13
Life Fitness Fit Test	15
Options - Edit Weight	17
Options - Select Language	18
Options - Connect Bluetooth® Device	19
Workout Mode Overview	20
Incline Interval Workout	21
Workout Metrics	22
Data Entry Options	23
Edit Goal	24
Pause Workout	25
Cool Down	26
Workout Summary - Logged In	27
Workout Summary - Not Logged In	28
Settings (Main) Menu / Diagnostics	29
Preventive Maintenance Tips	30
Troubleshooting	31
Integrity X Console Specifications	33
Warranty Information	34

Before using this product, it is essential to read this ENTIRE operation manual and ALL assembly instructions. It describes equipment setup and instructs members on how to use it correctly and safely.

Avant d'utiliser ce produit, il est indispensable de lire ce manuel d'utilisation dans son INTÉGRALITÉ, ainsi que TOUTES les instructions d'installations.

Ce manuel explique comment installer l'équipement et comment l'utiliser correctement et sans danger.

FCC Warning - Possible Radio / Television Interference

EN ISO 20957 Class SB: Professional and / or commercial use.

Note: *This equipment has been tested and found to comply with the limits for a Class A digital device, pursuant to part 15 of the FCC rules. These limits are designed to provide reasonable protection against harmful interference when the equipment is operated in a commercial environment. This equipment generates, uses and can radiate radio frequency energy, and if not installed and used in accordance with the instruction manual, may cause harmful interference to radio communications. Operation of this equipment in a residential area is likely to cause harmful interference in which case the user will be required to correct the interference at his own expense.*

EN ISO 20957 Class H: Home use.

Note: *This equipment has been tested and found to comply with the limits for a Class B digital device, pursuant to part 15 of the FCC rules. These limits are designed to provide reasonable protection against harmful interference in a residential installation. This equipment generates, uses and can radiate radio frequency energy, and if not installed and used in accordance with the user manual, may cause harmful interference to radio communications. However, there is no guarantee that the interference will not occur in a particular installation. If this equipment does cause harmful interference to radio or television reception, which can be determined by turning the equipment off and on, the user is encouraged to try to correct the interference by one or more of the following measures:*

- Reorient or relocate the receiving antenna.
- Increase the separation between the equipment and the receiver.
- Connect the equipment into an outlet on a circuit different from that to which the receiver is connected.
- Consult the dealer or an experienced radio/TV technician for help.



CAUTION: Any changes or modifications to this equipment could void the product warranty.



MISE EN GARDE : tout changement ou toute modification de ce matériel peut annuler la garantie du produit.

Any service, other than cleaning or user maintenance, must be performed by an authorized service representative.

This Operation Manual describes the functions of the following products:

Integrity X Console for INTSX, INTDX, and Club Series Treadmills

See "Specifications" in this manual for product specific features.

Statements of Purpose:

- The Life Fitness Treadmill is an exercise machine that enables users to walk or run, in place, indoors on a moving surface.

CAUTION: Health-related injuries may result from incorrect or excessive use of exercise equipment. Life Fitness STRONGLY recommends seeing a physician for a complete medical exam before undertaking an exercise program, particularly if the user has a family history of high blood pressure or heart disease, is over the age of 45, smokes, has high cholesterol, is obese, or has not exercised regularly in the past year.

If, at any time while exercising, the user experiences faintness, dizziness, pain, or shortness of breath, he or she must stop well immediately.



MISE EN GARDE: Liés à la santé des blessures peuvent résulter de l'utilisation incorrecte ou excessive de l'équipement d'exercice. Life Fitness recommande FORTEMENT de consulter un médecin pour subir un examen médical complet avant de commencer tout programme d'exercice, et tout particulièrement si l'utilisateur a des antécédents familiaux d'hypertension ou de troubles cardiaques, s'il a plus de 45 ans, s'il fume, s'il a du cholestérol, s'il est obèse ou n'a pas fait d'exercice régulièrement depuis un an.





Si, pendant l'utilisation de l'appareil, l'utilisateur ressent un malaise, des vertiges, des douleurs ou des difficultés à respirer, il doit s'arrêter immédiatement.

IMPORTANT SAFETY INSTRUCTIONS

Read all instructions before using Life Fitness products.

 **WARNING:** Health-related injuries may result from incorrect or excessive use of exercise equipment. Life Fitness STRONGLY recommends seeing a physician for a complete medical exam before undertaking an exercise program, particularly if the user has a family history of high blood pressure or heart disease, is over the age of 45, smokes, has high cholesterol, is obese, or has not exercised regularly in the past year. If, at any time while exercising, the user experiences faintness, dizziness, pain, or shortness of breath, he or she must stop immediately.

 **CAUTION:** Any changes or modifications to this equipment could void the product warranty.

 **DANGER:** To reduce the risk of electrical shock, always unplug Life Fitness products before cleaning or attempting any maintenance activity.

 **WARNING:** To reduce the risk of burns, fire, electric shock, or injury, it is imperative to connect each product to a properly grounded electrical outlet.

 **WARNING:** Heart rate monitoring systems may be inaccurate. Over exercising may result in serious injury or death. If you feel faint, stop exercising immediately.

 **WARNING:** Keep the area 6.5 ft. (2 m) by 3 ft. (0.9 m) behind the Life Fitness treadmill clear of any obstructions, including walls, furniture, and other equipment. Contact Life Fitness Customer Support Services for an optional longer power cord if necessary.

 **WARNING:** Be sure the emergency stop lanyard is clipped to the user and in proper position on the treadmill before beginning any workout.

 **WARNING:** The belt centering adjustment must be performed if the belt is not between the marks indicating the maximum allowed lateral positions. Refer to Treadmill Assembly Instructions.

 **CAUTION:** Risk of injury to persons - to avoid injury, use extreme caution when stepping onto or off of a moving belt.

- Read assembly instruction manual before using.
- Never operate a Life Fitness product if it has a damaged power cord or electrical plug, or if it has been dropped, damaged, or even partially immersed in water. Contact Life Fitness Customer Support Services.
- Position the product so that the power cord plug to the wall is accessible to the user. Make sure that the power cord is not knotted or twisted and that it is not trapped under any equipment or other objects.
- If the electrical supply cord is damaged, it must be replaced by the manufacturer, an authorized service agent, or a similarly qualified person to avoid a hazard.
- Always follow the console instructions for proper operation.
- This appliance is not intended for use by persons (including children) with reduced physical, sensory, or mental capabilities, or lack of experience or knowledge unless they have supervision or been given instruction concerning the use of the appliance by a person responsible for their safety. Keep children under the age of 13 away from the machine.
- Do not use this product outdoors, near swimming pools or in areas of high humidity.
- Never operate a Life Fitness product with the air openings blocked. Keep air openings free of lint, hair, or any other obstructing material.
- Never insert objects into any opening in these products. If an object should drop inside, turn off the power, unplug the power cord from the outlet, and carefully retrieve it. If the item cannot be reached, contact Life Fitness Customer Support Services.
- Never place liquids of any type directly on the unit, except in an accessory tray or holder. Containers with lids are recommended.
- Do not use these products in bare feet. Always wear shoes. Wear shoes with rubber or high-traction soles. Do not use shoes with heels, leather soles, cleats or spikes. Make sure no stones are embedded in the soles.

IMPORTANT SAFETY INSTRUCTIONS

- Keep all loose clothing, shoelaces, and towels away from moving parts.
- Do not reach into, or underneath, the unit or tip it on its side during operation.
- Keep children away from the products. Do not allow other people to interfere in any way with the user or equipment during a workout.
- Allow LCD consoles to “normalize” with respect to temperature for one hour before plugging the unit in and using.
- The product should never be left unattended when plugged in. Disconnect from the electrical outlet when not in use, and before putting on or taking off parts. To disconnect, turn power OFF at the ON/OFF switch, then remove plug from electrical outlet.
- Keep the power cord away from heated surfaces. Do not pull the equipment by the power cord or use the cord as a handle. Do not run the power cord on the floor under or along the side of the treadmill.
- Handrails may be held to enhance stability as needed, but are not for continuous use.
- Never mount or dismount the treadmill while the running belt is moving. Use the handrails whenever additional stability is required. In case of an emergency, such as tripping, grasp the handrails, and place the feet on the side platforms.
- Never walk or jog backwards on the treadmill.
- Do not use this product in areas where aerosol spray products are being used or where oxygen is being administered. Such substances create the danger of combustion and explosion.
- The system causes immobilization of the treadmill when a pre-defined hard key sequence has been activated. This sequence is currently defined as 3 STOP key presses followed by 3 SPEED DOWN ARROW key presses. To prevent false toggling of the Immobilized feature, this sequence must be done in a 5-10 second period.
- Use these products for their intended use as described in this manual. Do not use attachments that have not been recommended by the manufacturer.
- In conformity with the European Union Machinery Directive 2006/42/EC, this equipment unloaded runs at sound pressure levels below 70 dB (A) at the average operating speed of 12 km/hr (commercial units) and 8 km/hr (home units). Noise emission under load is higher than without load.
- Read all warnings on each product prior to starting a workout.
- Free standing equipment shall be installed on a stable and leveled base.
- If warnings are missing or damaged, please contact Life Fitness immediately for replacement warning labels. Warning labels are shipped with every product and should be installed before product is used. Life Fitness is not responsible for missing or damaged warning labels.
- Health and Environmental Regulations Warning - This product may contain chemicals known to the State of California to cause cancer, birth defects, or other reproductive harm. For more information related to the European Commission Regulation (EC) No. 1907/2006 (REACH) and the California Safe Drinking Water and Toxic Enforcement Act of 1986 (Proposition 65), please visit <https://www.lftechsupport.com/web/guest/environmental-regulations-information>.

**SAVE THESE INSTRUCTIONS FOR
FUTURE REFERENCE.**

INTEGRITY X CONSOLE OVERVIEW



1. Touch Screen Display

Press to select, set up, monitor and save workouts.

2. GO

Press to automatically begin a Quick Start workout.

3. Pause

Press to Pause a workout.

Club Series only:

Note: The unit will enter Energy Saving Mode after 5 minutes of inactivity, with a warning at 4:45 that energy saving is about to start. To wake the console, step on the treadmill or push the green "Go" button. When successful, a beep will be heard and the LCD screen will show the Life Fitness logo. The unit will take approximately 25 seconds to allow you to start a workout.

4. STOP

Press to Stop a workout.

5. Incline Display

Displays current incline.

6. Speed Display

Displays current speed.

7. UP and DOWN arrow keys

Use to increase / decrease speed.

8. Reading Rack / Tablet Holder

Place traditional reading material as well as mobile devices and tablets in this built-in holder.

9. USB Port

Charge USB devices.

ENTERTAINMENT RACK OVERVIEW



The Entertainment Rack is used with an optional Life Fitness Attachable TV or MYE receiver.

1. Closed Caption

Press to enable Closed Caption.

2. Mute

Press to turn off sound.

3. Volume UP / Down keys

Use these keys to adjust volume.

4. Channel UP /Down keys

Use these keys to change channels.

5. Power

Press to turn the TV on.

6. USB Port

Charge USB devices.

7. Headphone Jack

Plug in headphones to listen to TV and entertainment options.

HOME SCREEN OVERVIEW

The intuitive touch screen on the console allows users to select, set up, monitor, and save workouts.

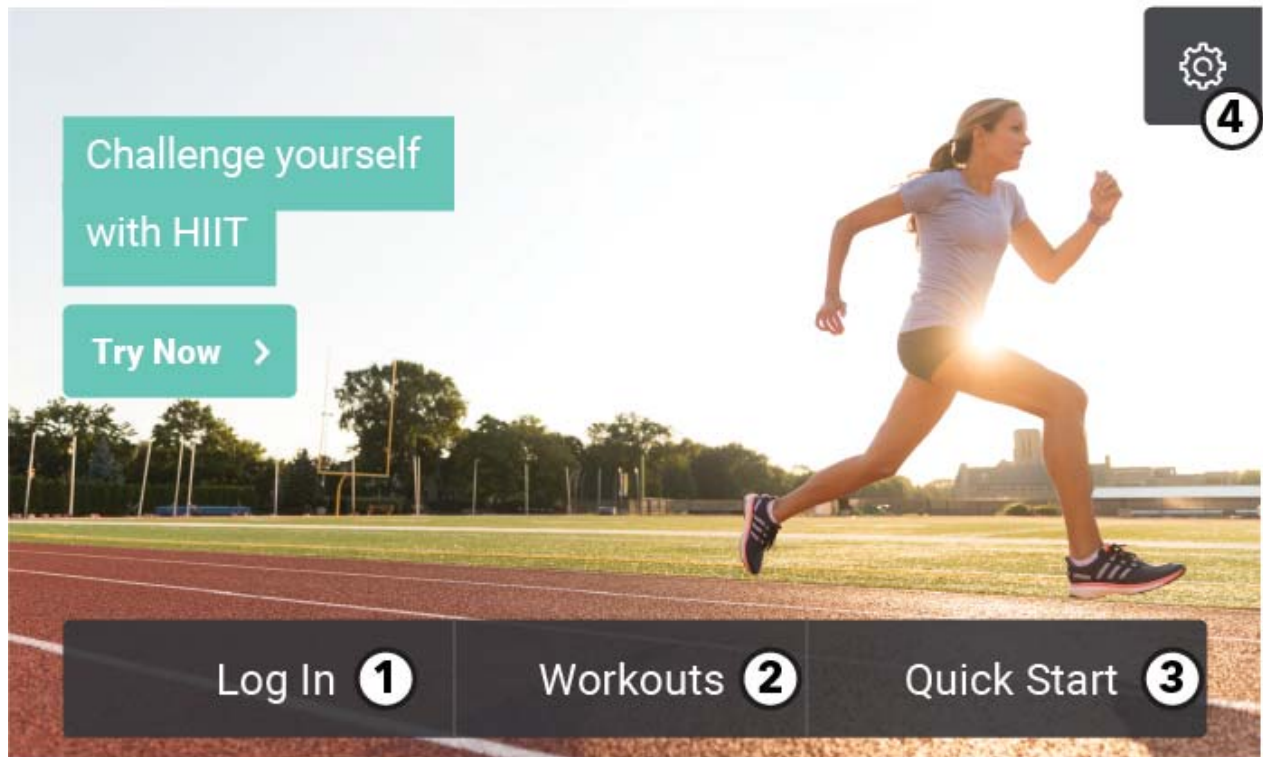

1. Log In

Press to log in to your LFconnect account.

2. Workouts

Select a pre programmed workout.

3. Quick Start

Press to immediately begin a workout.

4. Options

Press to access the Options Menu.

LOG IN



Log in to the console to track and save your workouts to the LFconnect app.

1. Scan QR Code

- Open the LFconnect app on your mobile device.
- Select the QR code reader in the upper right hand corner.
- Scan the QR code with your phone.

2. Proximity

- On an **iPhone**, enable Bluetooth, open the LFconnect app and turn on Bluetooth proximity login feature.
- On an **Android**, enable NFC and open the LFconnect app.
- Follow the prompts on the LFconnect app: Touch phone to the upper right hand corner of the console to automatically connect.

3. Information

Press to get information on the LFconnect app.

4. Back Arrow

Press to return to Home Screen.

LOG IN - WELCOME SCREEN

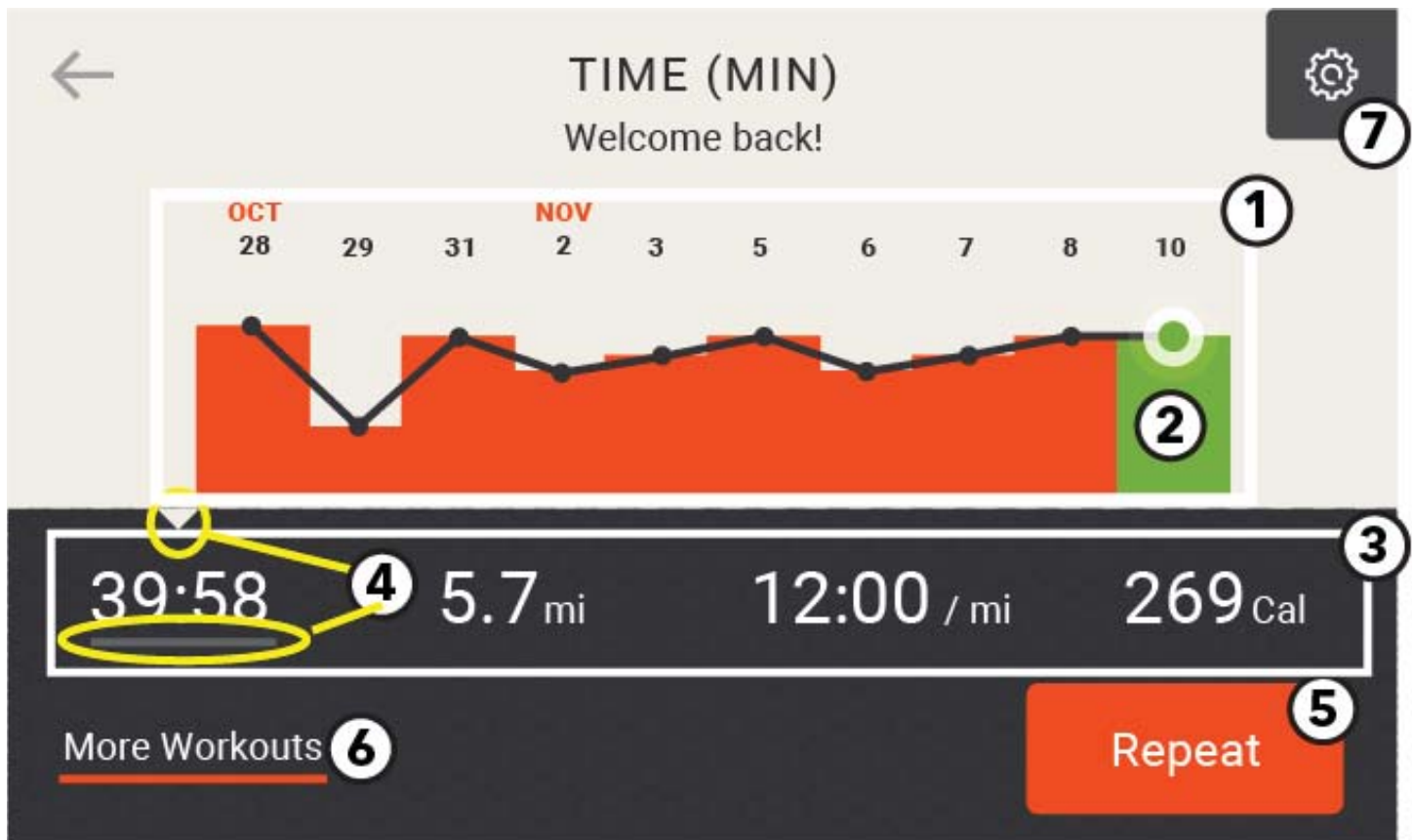

Personalized screen shows users their previously saved workout data.

- 1. Workout Data**
Previous 10 saved workout dates and results are shown.
- 2. Current Workout Result**
Pulsing green dot indicates current workout results.
- 3. Workout Metric**
Tap a specific workout metric to view the history of that metric on the graph.
- 4. Triangle and Underline Indicators**
The triangle and underline indicate the selected workout metric.
- 5. Repeat**
Repeat a previous workout.
- 6. More Workouts**
Press to access the Select Workout Menu.
- 7. Options Menu**
Press to access the Options Menu.

SELECT WORKOUT

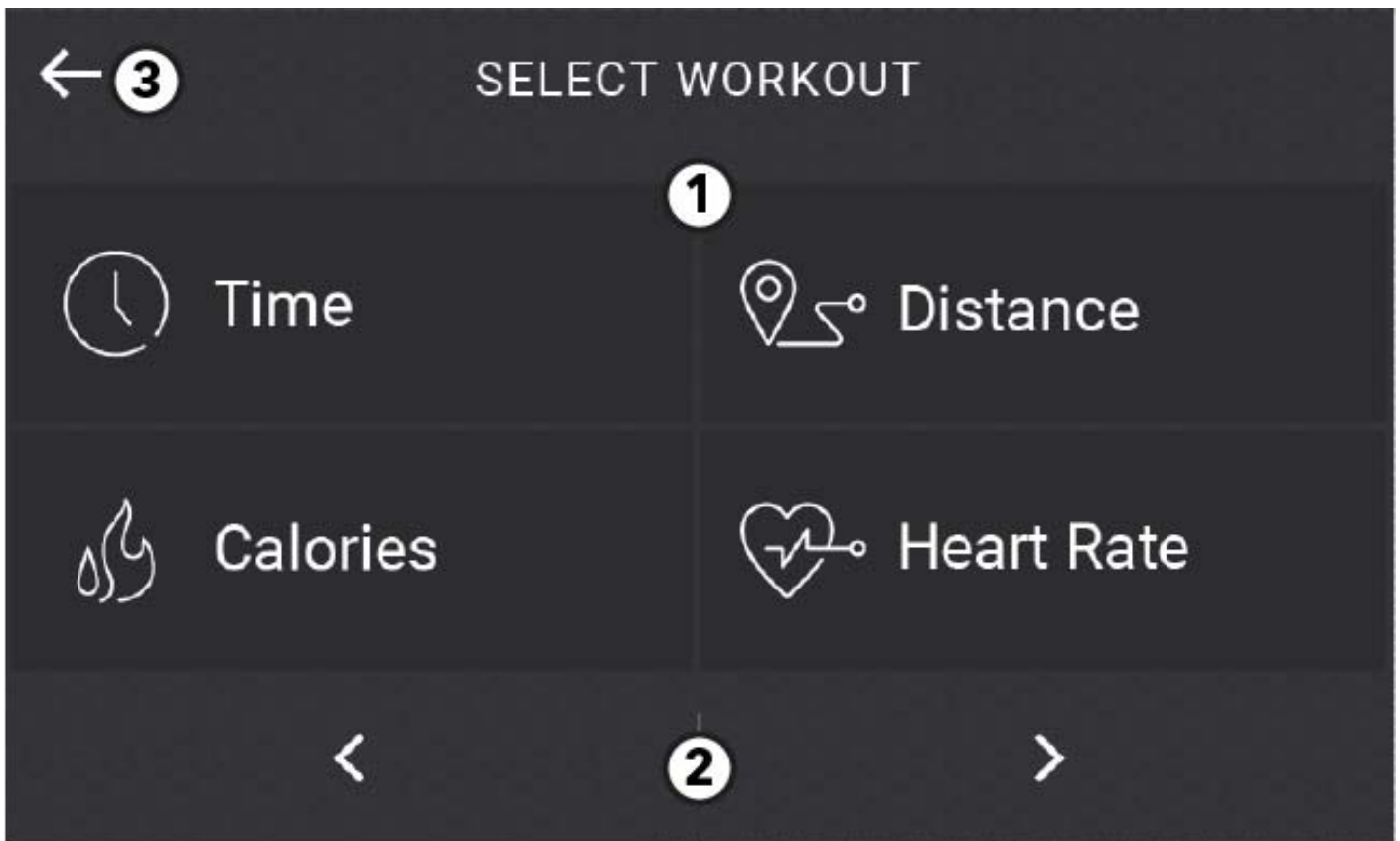

1. Workout Options

Select from the following workouts:

- **Time**
Set a time goal for a workout.
- **Calories**
Set a number of calories to burn during a workout.
- **Distance**
Set a distance goal for a workout.
- **Heart Rate**
Set a target heart rate to maintain during a workout.

2. Right and Left Arrows

Press to scroll through these additional workouts:

- **Random**
Adapt to incline levels that randomly change during a workout.
- **Hill**
Take on a hill. Incline level gradually increases during the first half of the workout and then gradually decreases during the second half.
- **Manual**
Control the incline level or speed manually during a workout.

▪ **Rolling Hills**

Choose the intensity of a series of up and down incline levels.

▪ **Speed Interval**

Choose between Manual and Automatic options.

The Manual option allows you to select between three speeds set by you during workout setup.

The Automatic option allows you to preselect two speed levels and interval durations that the machine automatically changes during a workout.

▪ **Incline Interval**

Choose between Manual and Automatic options.

The Manual option allows you to select between three incline levels set by you during workout setup.

The Automatic option allows you to preselect two incline levels and interval durations that the machine automatically changes during a workout.

▪ **Life Fitness Fit Test**

Take a 5-minute VO_2 submax evaluation designed to determine cardiovascular fitness level.

3. **Exit** the Workout Selection Screen and return to the Home Screen.

HEART RATE WORKOUTS

Research shows that maintaining a specific heart rate while exercising is the optimal way to monitor the intensity of a workout and to achieve maximum results. That is the idea behind the Life Fitness Heart Rate Zone Training approach to exercise. Zone Training identifies an exerciser's ideal heart rate range, or zone, for burning fat or increasing cardiovascular fitness. The zone is a percentage of the theoretical maximum (HRmax), and its value depends on the workout. The maximal heart rate formula is defined by the American College of Sports Medicine's *Guidelines for Exercise Testing and Prescription*, 8th Edition, 2010. HRmax equals to 206.9 minus the total of 0.67 multiplied by a person's age.

$$\text{HR Max} = 206.9 - (0.67 * \text{age})$$

Theoretical Maximum Heart Rates and Target Heart Rates

Reference the chart below for Theoretical Maximum Heart Rates and Target Heart Rates.

Age	Theoretical Maximum Heart Rate	65% (Moderate Burn)	80% (Vigorous Burn)
10	200	130	160
20	194	126	155
30	187	121	149
40	180	117	144
50	173	113	139
60	167	108	133
70	160	104	128
80	153	100	123
90	147	95	117
99	141	91	112

Wear the optional Polar® telemetry heart rate chest strap, or grip the Lifepulse™ sensors, to enable the on-board computer to monitor the heart rate during a workout. The computer automatically adjusts the incline level to maintain the target heart rate based on the actual heart rate.

The Polar® Telemetry Heart Rate Chest Strap

The Polar telemetry heart rate monitoring system transfers heart rate signals to the console when electrodes are pressed against the skin. These electrodes are attached to a Polar telemetry heart rate chest strap that the user wears during the workout. The Polar telemetry heart rate chest strap is optional. Contact Life Fitness Customer Support Services to order.

See the diagram to the right of this paragraph for correct positioning of the Polar telemetry heart rate chest strap. The electrodes (A), which are the two grooved surfaces on the underside of the strap, must remain wet to transmit accurately the electrical impulses of the heart back to the receiver. Moisten the electrodes. Then, secure the Polar telemetry heart rate chest strap as high under the chest muscles as possible. The strap should be snug, but comfortable enough to allow for normal breathing.

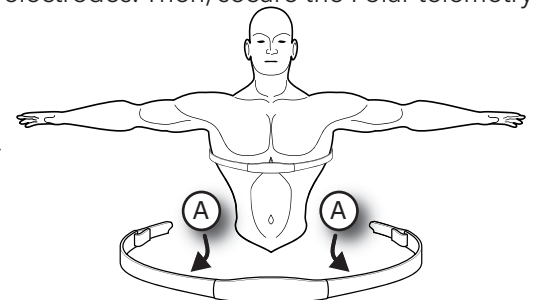

The transmitter strap delivers an optimal heart rate reading when the electrodes are in direct contact with bare skin. However, it functions properly through a thin layer of wet clothing. If it becomes necessary to re-moisten the Polar telemetry heart rate chest strap electrodes, grasp the center of the strap, pull it away from the chest to expose the two electrodes, and re-moisten them.

Note: If the Lifepulse system sensors are grasped while the chest strap is worn, and if the signals from the sensors are valid, the on-board computer uses these sensor signals for calculating the heart rate instead of those transmitted by the Polar telemetry heart rate chest strap.

Note: Do not attempt to grasp the sensors on a treadmill at speeds above 4.5 mph or 7.2 kph. For these speeds, the use of a Polar telemetry heart rate chest strap is recommended.

HEART RATE WORKOUTS

The Lifepulse™ System

The patented Lifepulse system sensors (A) are the built-in heart rate monitoring system on this product. For the most accurate reading possible, during a workout:

- Grasp the sensors firmly.
- Hold each sensors at the midpoint.
- Keep hands steady and in place.

The console displays the heart rate within 10 to 40 seconds after the user grasps the sensors. The following factors may affect a Lifepulse reading:

- incorrect hand placement on the sensors,
- upper body activity, lotion or dirt on hands, and
- excessive or insufficient pressure used when gripping the sensors.

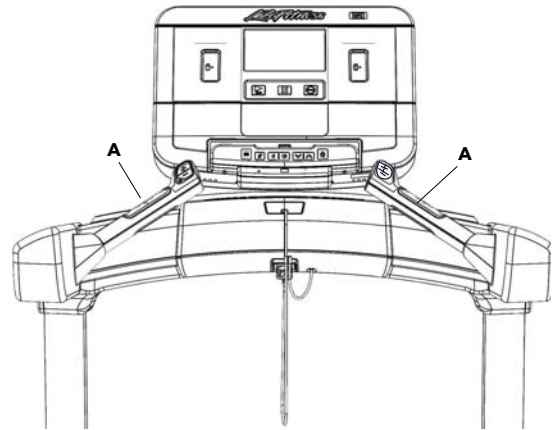

Note: Do not attempt to grasp the sensors on a treadmill at speeds above 4.5 mph or 7.2 kph. For these speeds, the use of a Polar telemetry heart rate chest strap is recommended.

LIFE FITNESS FIT TEST

- **Select FIT TEST on the Workout Selection Screen.**
- The Life Fitness Fit Test estimates cardiovascular activity and can be used to monitor improvements in endurance every 4 - 6 weeks.
- The Fit Test is considered to be a submax VO_2 (volume or oxygen) test and gauges how well the heart supplies oxygenated blood to the exercising muscles and how efficiently those muscles receive oxygen from the blood.
- Physicians and exercise physiologists generally regard this test as a good measure of aerobic capacity.
- Workout duration is 5 minutes total.
- Take the Fit Test under similar circumstances each time. For the most accurate Fit Test results, you should perform the Fit Test on three consecutive days and average the three scores.
- To receive a proper Fit Test score, the work done must be within a training heart rate zone that is 60% to 85% of the theoretical maximum heart rate (HRmax).

The user must grasp the hand sensors when prompted, or wear a Polar telemetry heart rate chest strap as the test score calculation is based on a heart rate reading.

Note: *The workout will be terminated if a heart rate is not detected after 2.5 minutes.*

Your heart rate is dependent on many factors, including:

- amount of sleep the previous night (*at least 7 hours is recommended*)
- time of day
- time you last ate (*2 - 4 hours after the last meal is recommended*)
- time since you last drank a liquid containing caffeine or alcohol, or smoked a cigarette (*at least 4 hours is recommended*)
- time since you last exercised (*at least 6 hours is recommended*)

Suggested exertion levels should be used as a guideline for setting up the Fit Test program. The goal is to elevate the user's heart rate to a level that is between 60%-85% of their theoretical maximum heart rate.

	Inactive	Active	Very Active
Treadmill	2 -3 mph (3.2 - 4.8 kph)	3 - 4 mph (4.8 - 6.4 kph)	3.5 - 4.5 mph (5.6 - 7.2 kph)

Within each suggested range, use these additional guidelines:

Lower Half of Range	Upper Half of Range
higher age	lower age
lower weight	higher weight <i>(in cases of excessive weight, use lower half of range)</i>
shorter	taller

LIFE FITNESS FIT TEST

After the 5-minute FIT TEST is completed, a FIT TEST score and rating will be displayed.

Please note that the estimated VO₂ max scores achieved will be 10-15% lower on stationary exercise bikes than those achieved on other Life Fitness cardiovascular equipment. Stationary cycling has a higher rate of isolated muscle fatigue of the quadriceps when compared to walking / running on a treadmill or utilizing a bike. This higher rate of fatigue corresponds to lower levels of estimated VO₂ max scores.

Relative Fitness Classification for MEN

Rating	VERY ACTIVE		ACTIVE			INACTIVE		
	<i>Elite</i>	<i>Excellent</i>	<i>Very Good</i>	<i>Above Average</i>	<i>Average</i>	<i>Below Average</i>	<i>Low</i>	<i>Very Low</i>
Estimated VO₂ Max (ml/kg/min) per Age category								
20 - 29 years	55+	53 - 54	50 - 52	45 - 49	40 - 44	38 - 39	35 - 37	<35
30 - 39 years	52+	50 - 51	48 - 49	43 - 47	38 - 42	36 - 37	34 - 35	<34
40 - 49 years	51+	49 - 50	46 - 48	42 - 45	37 - 41	34 - 36	32 - 33	<32
50 - 59 years	47+	45 - 46	43 - 44	39 - 42	34 - 38	32 - 33	29 - 31	<29
60+ years	43+	41 - 42	39 - 40	35 - 38	31 - 34	29 - 30	26 - 28	<26

Relative Fitness Classification for WOMEN

Rating	VERY ACTIVE		ACTIVE			INACTIVE		
	<i>Elite</i>	<i>Excellent</i>	<i>Very Good</i>	<i>Above Average</i>	<i>Average</i>	<i>Below Average</i>	<i>Low</i>	<i>Very Low</i>
Estimated VO₂ Max (ml/kg/min) per Age category								
20 - 29 years	47+	45 - 46	43 - 44	38 - 42	33 - 37	31 - 32	28 - 30	<28
30 - 39 years	44+	42 - 43	40 - 41	36 - 39	31 - 35	29 - 30	27 - 28	<27
40 - 49 years	42+	40 - 41	38 - 39	34 - 37	30 - 33	28 - 29	25 - 27	<25
50 - 59 years	37+	35 - 36	33 - 34	30 - 32	26 - 29	24 - 25	22 - 23	<22
60+ years	35+	33 - 34	31 - 32	27 - 30	24 - 26	22 - 23	20 - 21	<20

Life Fitness developed this rating scale based on VO₂ max percentile distributions referenced in *American College of Sports Medicine's Guidelines for Exercise Testing and Prescription* (8th E. 2010). It is designed to provide a qualitative description of a user's VO₂ max estimation, and a means of assessing initial fitness level and tracking improvement.

OPTIONS - EDIT WEIGHT

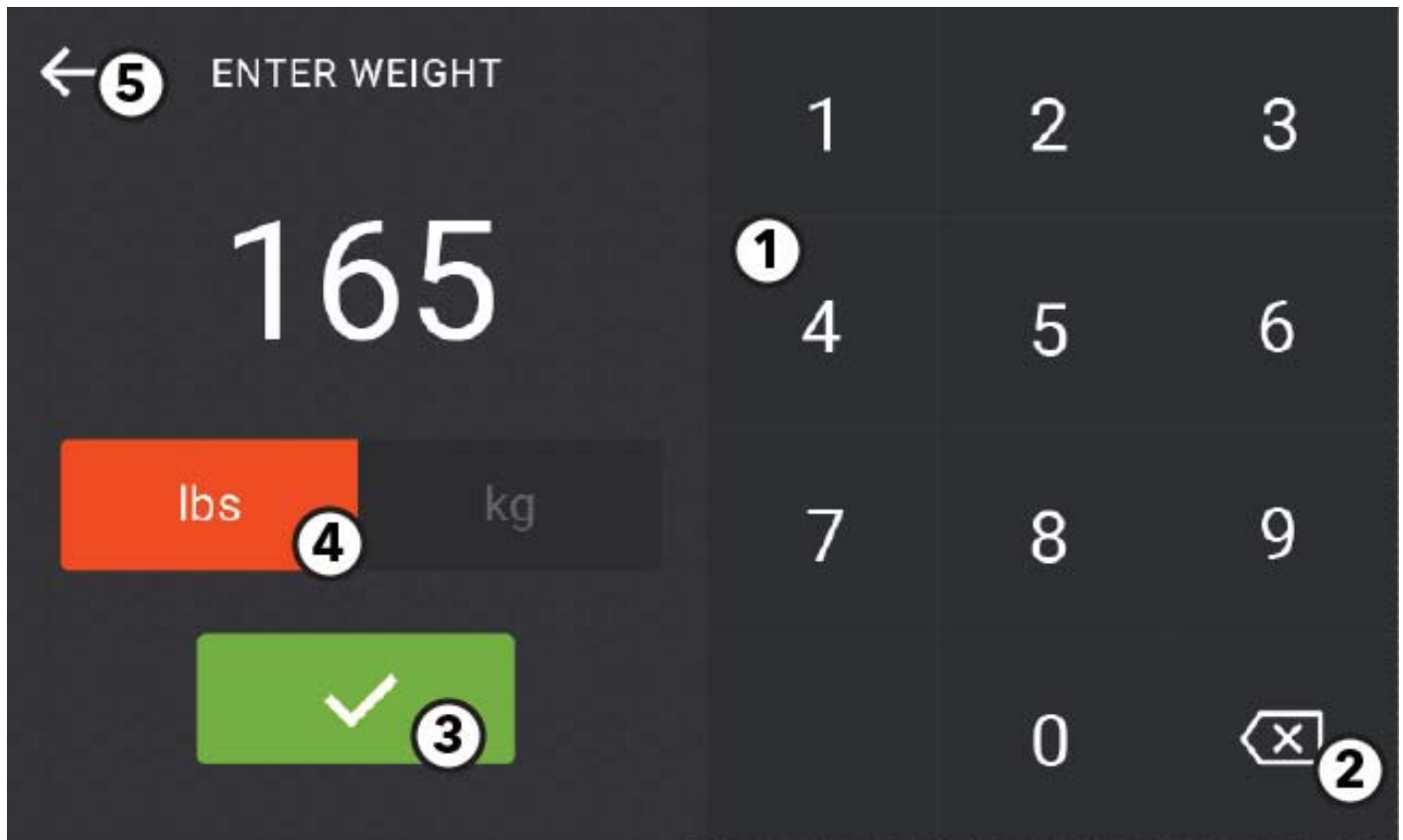

1. Numeric Keypad

Input a weight value.

2. Delete

Press to delete an incorrect data entry.

3. Accept the weight value. The updated value will show on the Edit Weight button on the Options Menu.

4. Select metric or imperial unit.

5. Exit the Weight Entry Screen and return to the Options Menu.

OPTIONS - SELECT LANGUAGE

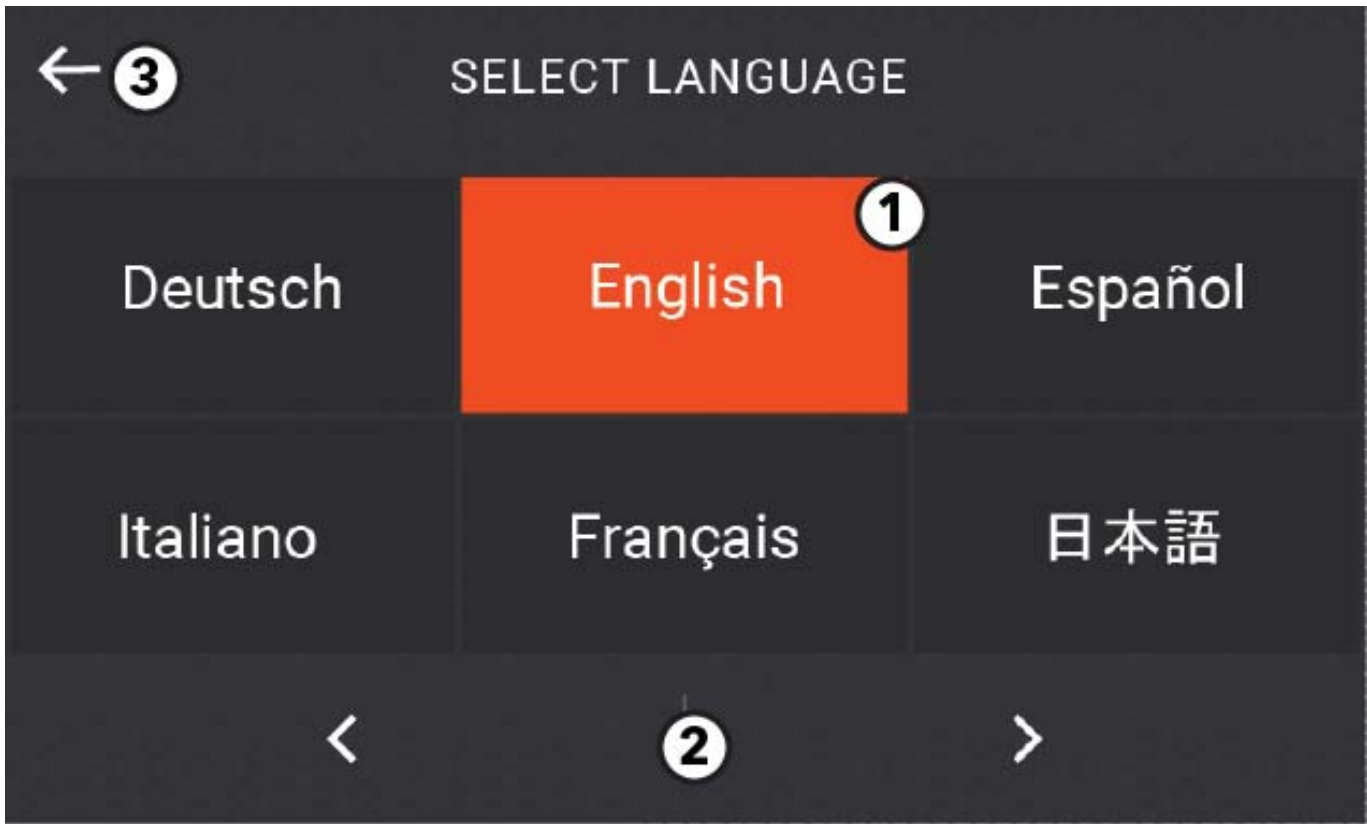

1. Language Options

Select a language to use during a workout.

Note: The default language can be changed by the manager.

2. Right and Left Arrow

Press to scroll through additional language options.

3. Exit the Language Selection Menu and return to the Options Menu.

OPTIONS - CONNECT BLUETOOTH DEVICE

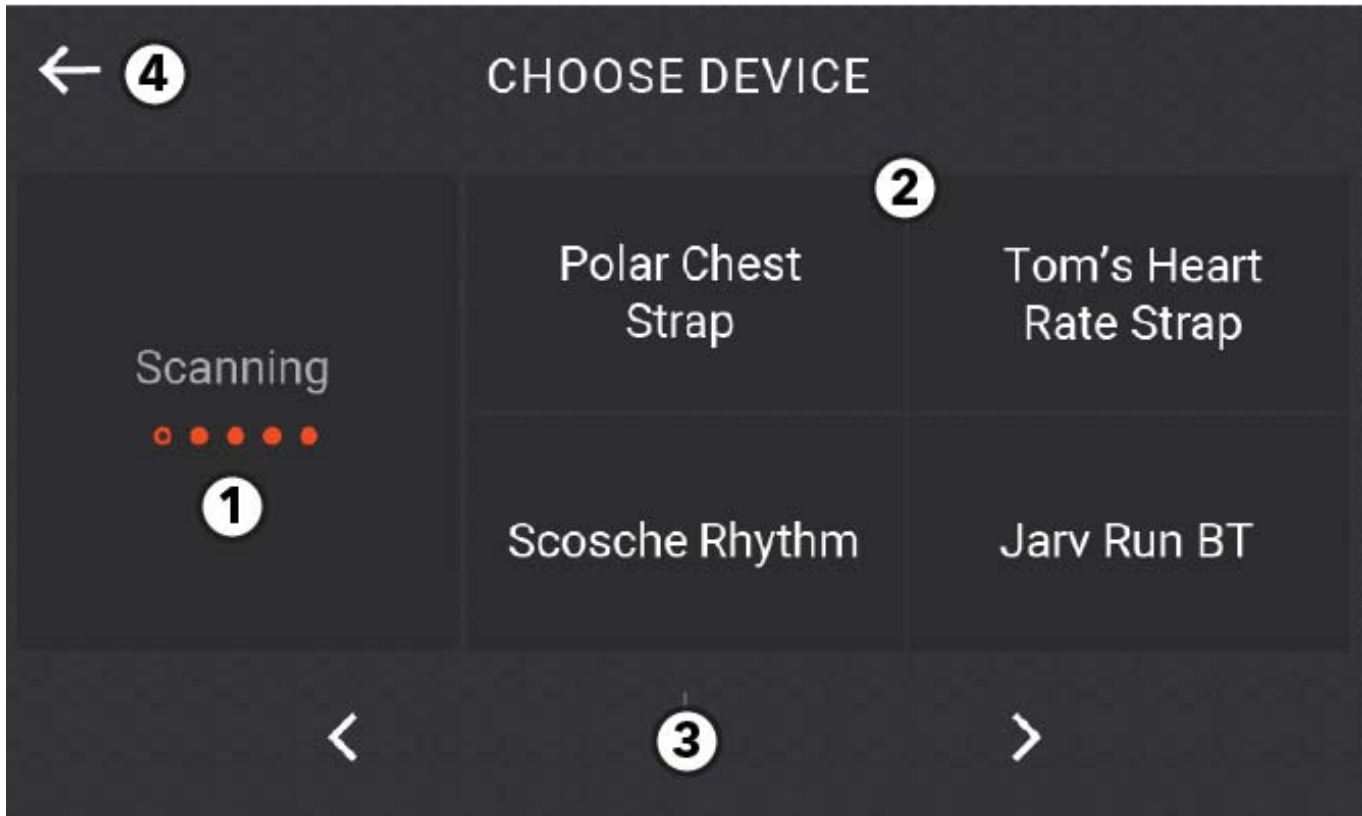

1. Bluetooth Module Scan

Scans for available devices. Once the scan is complete, a “rescan” button replaces the “Scanning” message.

2. Select Device

User can tap on any item at any time during the scan.

3. Right and Left Arrow

Press to scroll through additional devices.

4. Exit the Bluetooth Connection Screen and return to the Home Screen.

WORKOUT MODE OVERVIEW



1. Mini Classic Graph

- Graph shows upcoming changes in level.
- Tap the graph to display the full screen graph.

2. Primary Goal Progress Ring

The orange ring shows accumulated progress towards selected goal.

3. Mini-Goal

A smaller unit of the primary goal is displayed.

4. Progress Dots

Each dot is a progress indicator. When the progress timer completely covers the dot, the next dot lights up orange and begins blinking .

5. Primary Goal Metric

- Displays current value of the primary workout goal.
- Tap to edit main goal.

6. Target Goal

Displays the target goal.

7. Bottom Left (Secondary) Metric

- Displays current value of the secondary workout goal.
- Tap the metric to display live workout stats.

8. Bottom Right (Tertiary) Metric

- Displays current value of the workout goal.
- Tap the metric to display live workout stats.

Heart Rate Display (not shown)

Shows current heart rate from one of the following:

- contact heart rate
- polar strap (when active)
- Bluetooth strap (when connected)

Contact Heart Rate and Polar icon



Bluetooth Heart rate icon.



INCLINE INTERVAL WORKOUT



Choose MANUAL or AUTOMATIC.

1. Manual Selection

- Set three quick incline levels.
- Use the preset levels or use the up and down arrows to adjust the levels.
- Tap the green check mark to enter selection.

2. Automatic Selection

- Set two incline levels and two interval durations.
- Use the preset levels or use the up and down arrows to adjust the levels / time.
- Tap the green check mark to enter selections.

WORKOUT METRICS

Workout Type	Center Metric	Bottom Left Metric	Bottom Right Metric
Time	Time	Calories	Distance
Distance	Distance	Calories	Time Elapsed
Calories	Calories	Distance	Time Elapsed
Heart Rate	Heart Rate	Calories	Distance
Random	Time	Calories	Distance
Manual	Time	Calories	Distance
Hill	Time	Calories	Distance
Rolling Hills	Time	Calories	Distance
Incline Interval (Manual)	Time Incline	Calories	Distance
Incline Interval (Automatic)	Time	Calories	Distance
Speed Interval (Manual)	Time Speed	Calories	Distance
Speed Interval (Automatic)	Time	Calories	Distance
LF Fit Test	Time	Calories	Distance

DATA ENTRY OPTIONS - INTSX, INTDX, & CLUB SERIES TREADMILLS

WORKOUT TYPE	USER INPUT
Time	3 preset values or use keypad to input desired time
	Incline Level
	Weight (<i>enter through Settings Menu</i>)
Distance	3 preset values or use keypad to input desired distance
	Incline Level
	Weight (<i>enter through Settings Menu</i>)
Calories	3 preset values or use keypad to input desired calories
	Weight
	Incline Level
Heart Rate	Age
	Target Heart Rate
	Time (<i>3 preset values or use keypad to input desired time</i>)
	Incline Level
	Weight (<i>enter through Settings Menu</i>)
Random	Time (<i>3 preset values or use keypad to input desired time</i>)
	Incline Level (<i>use keypad to input desired incline level</i>)
	Weight (<i>enter through Settings Menu</i>)
Rolling Hills	Time (<i>3 preset values or use keypad to input desired time</i>)
	Incline Level (<i>use keypad to input desired incline level</i>)
	Weight (<i>enter through Settings Menu</i>)
Hill	Time (<i>3 preset values or use keypad to input desired time</i>)
	Incline Level (<i>use keypad to input desired incline level</i>)
	Weight (<i>enter through Settings Menu</i>)
Manual	Time (<i>3 preset values or use keypad to input desired time</i>)
	Incline Level (<i>use keypad to input desired incline level</i>)
	Weight (<i>enter through Settings Menu</i>)
Incline Interval	Time (<i>3 preset values or use keypad to input desired time</i>)
	Choose Manual or Automatic
	Manual (<i>set incline quick keys</i>)
	Automatic (<i>set two incline intervals and two time intervals</i>)
Speed Interval	Time (<i>3 preset values or use keypad to input desired time</i>)
	Choose Manual or Automatic
	Manual (<i>set speed quick keys</i>)
	Automatic (<i>set two speed intervals and two time intervals</i>)

EDIT GOAL

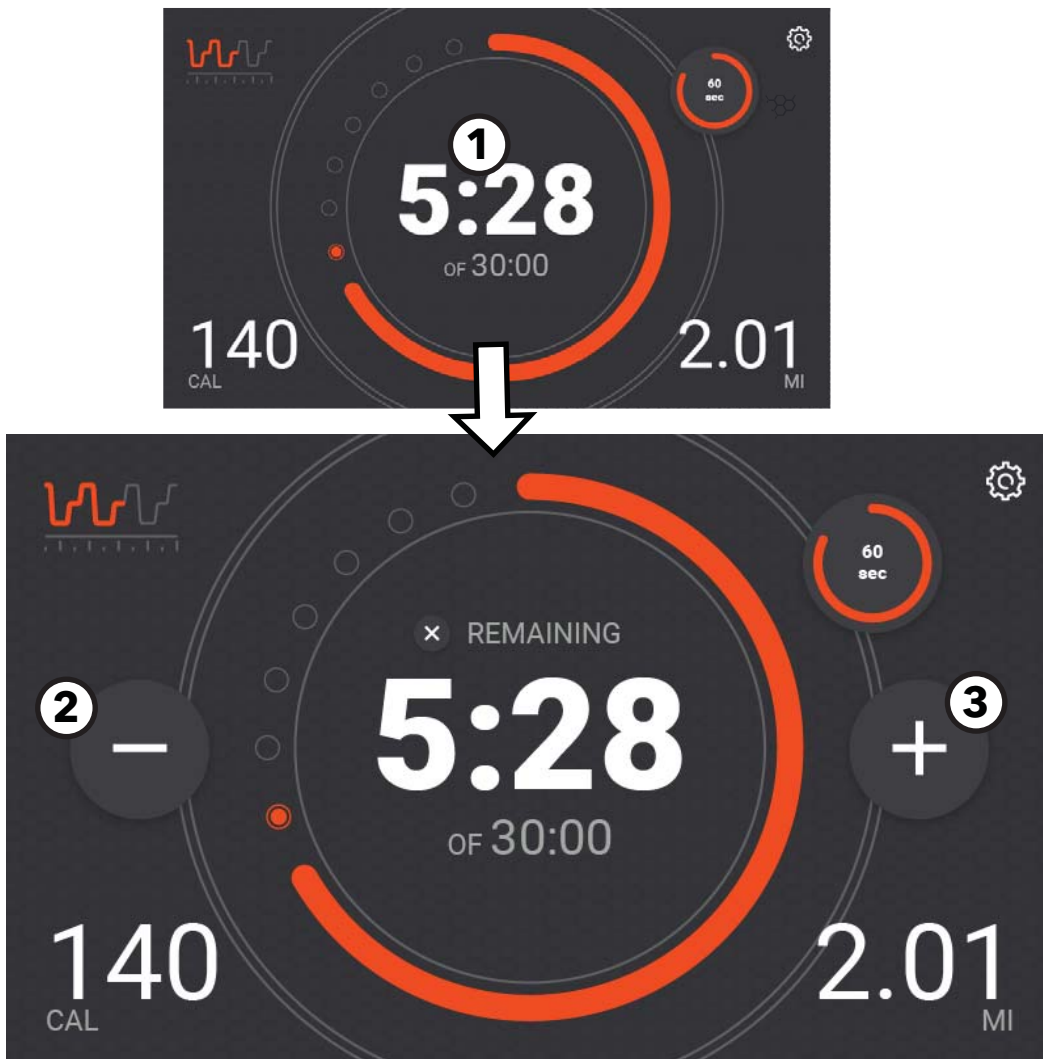

- 1. Primary Metric**
Tap on primary metric to edit the current goal.
- 2. Decrease (-)**
Press to decrease value of goal.
- 3. Increase (+)**
Press to increase value of goal.

PAUSE WORKOUT

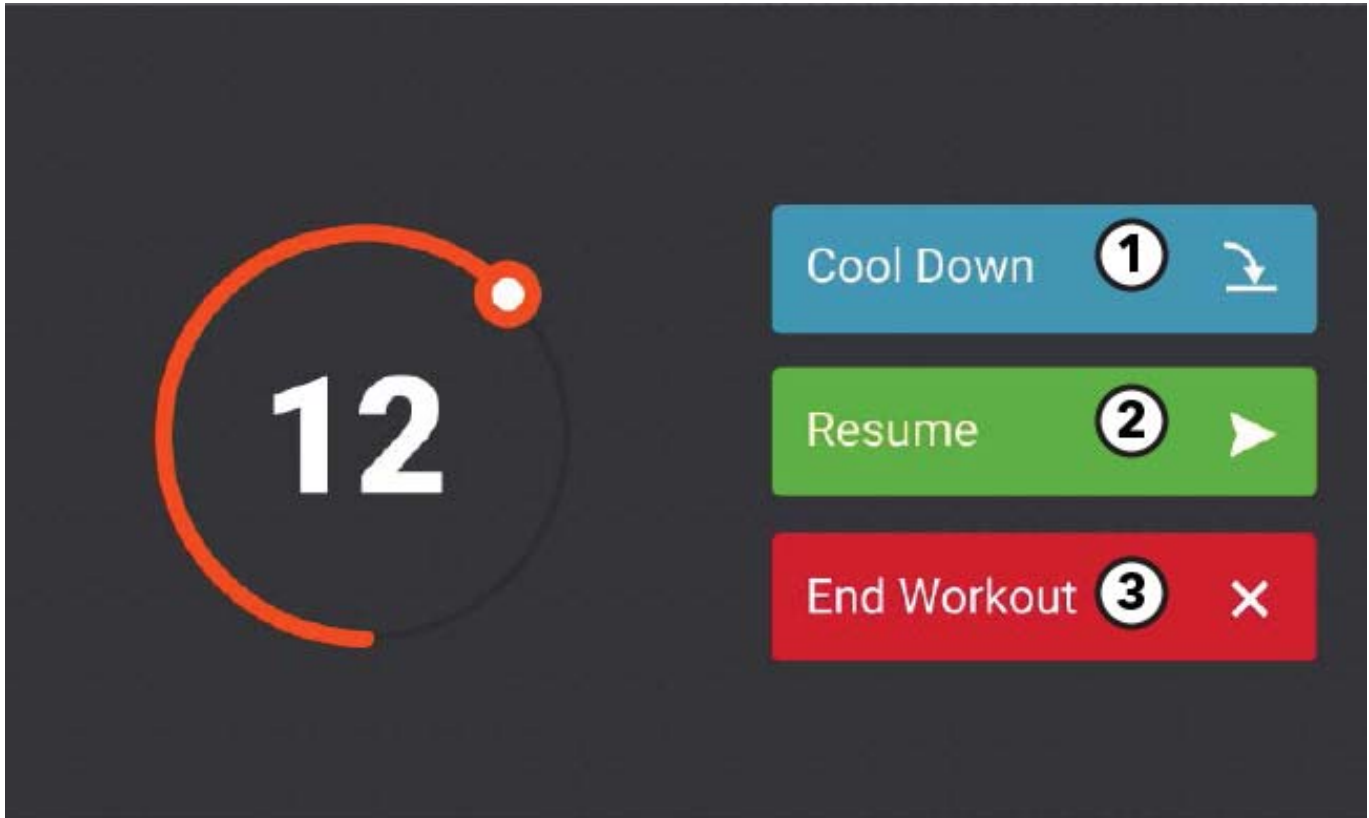

Press the Pause hard key anytime during a workout to pause a workout.

Choose one of the following options while in Pause mode:

- 1. Cool Down**
Press to enter a cool down mode.
- 2. Resume**
Press to continue current workout.
- 3. End Workout**
Press to end current workout and view workout summary.

COOL DOWN



Press the Pause hard key anytime during a workout to pause a workout and start a cool down mode..

1. Time Display

- "Cool down" is displayed in the dial when the cool down mode is entered.
- The time display initially shows the amount of time in minutes that a specific workout is required to be in Cool Down Mode.
- The time display will countdown until it reaches 0:00
- Tap the to edit the cool down time interval.

2. Decrease (-)

Press to decrease cool down time.

3. Increase (+)

Press to increase cool down time.

4. Exit Cool Down Mode.

WORKOUT SUMMARY - LOGGED IN



1. Workout Metrics

Tap a specific workout metric to view the history of that metric on the graph.

2. All Stats

Press to view the Workout Results Screen.

3. Workout Complete Timer

- Workout results are displayed for 30 seconds. The orange dot and tail spin every second counting down from 30 until it reaches 0.
- Press the timer to stop the countdown and close the Workout Results Screen.

- Exit** the Workout Results Screen by selecting back arrow in upper left hand corner and return to the Workout Summary screen.

WORKOUT SUMMARY - NOT LOGGED IN

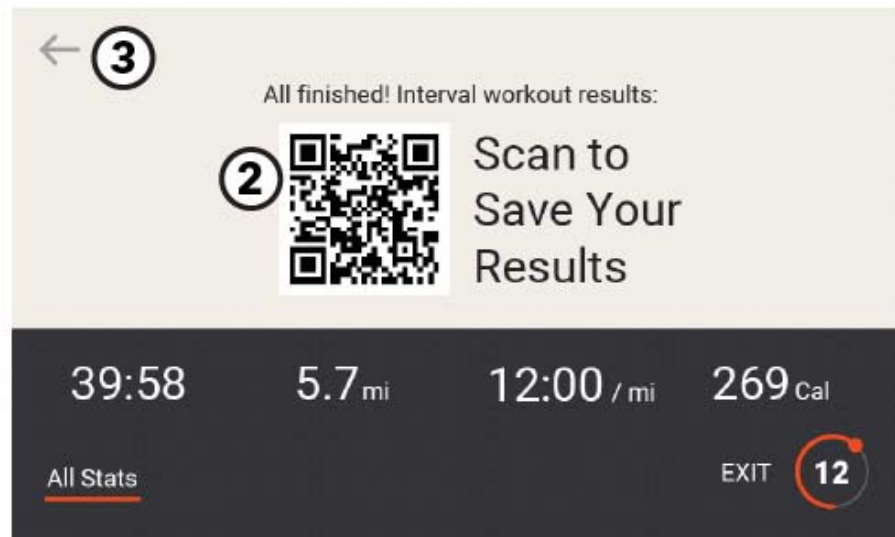
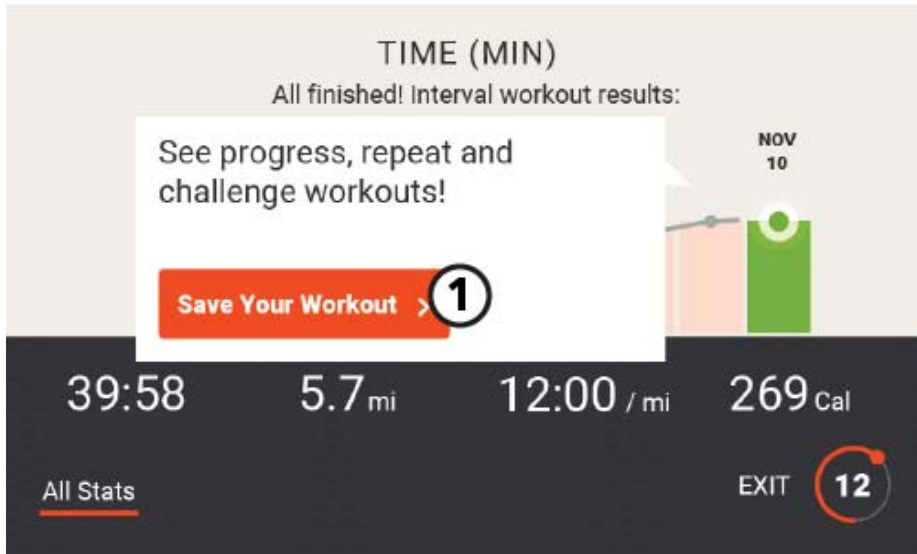

1. Save Workout

Press to view the QR Code to scan to save your results.

2. Scan to Save Workout Results

- Open the LFconnect app on your mobile device.
- Select the QR code reader in the upper right hand corner.
- Scan the QR code with your phone.

3. **Exit** and return to previous screen.

SETTINGS (MAIN) MENU / DIAGNOSTICS

Press the following key sequence to access the Settings Menu :

- Workouts on Home Screen
- Right Arrow Up, Right Arrow Down, Right Arrow Up Right Arrow Down
- Pause Hard Key

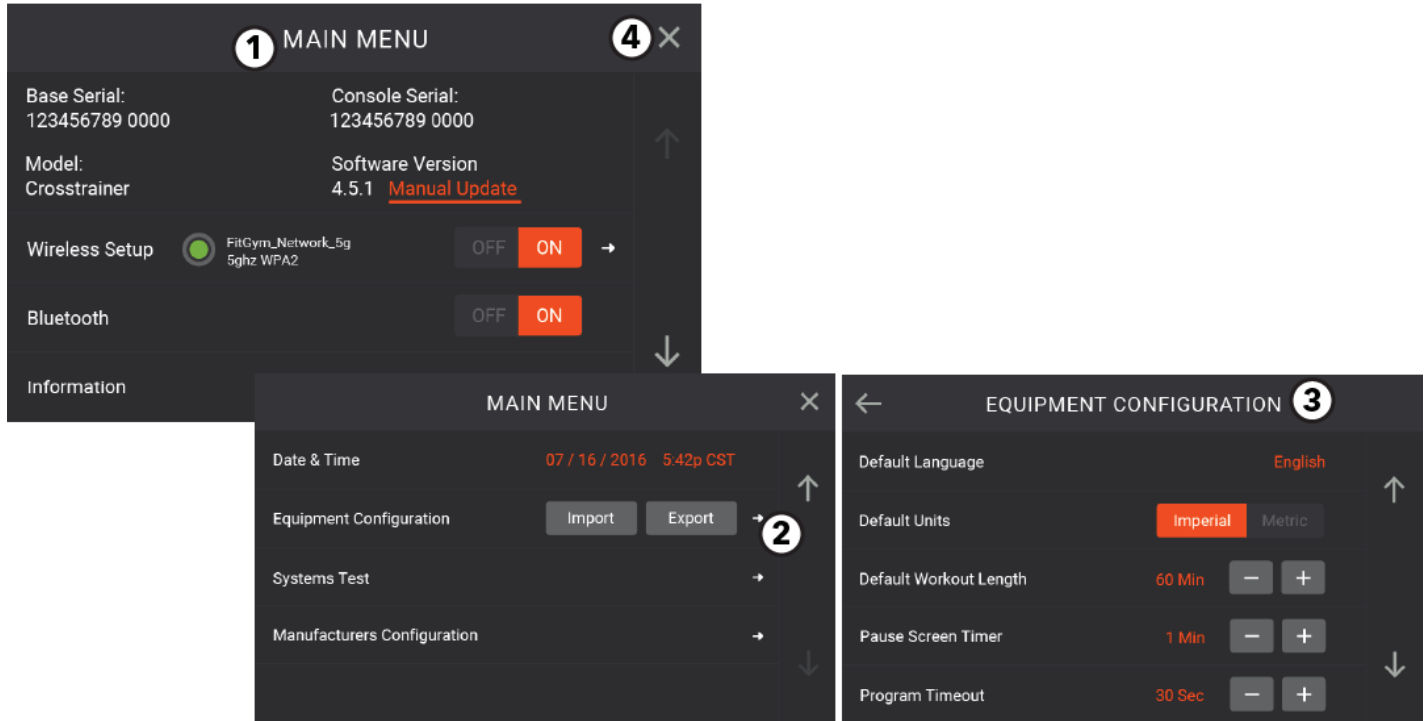

1. Main Menu

View unit information, update software through USB, and adjust settings. Use the Up and Down arrows to scroll through the screens.

2. Tap the **Equipment Configuration Next Page Arrow** to access additional adjustable settings.

3. Equipment Configuration Settings

Use the Up and Down arrows to scroll through the settings. Use either the "+" and "-" or the "ON" and "OFF" keys to adjust the following settings. Default values are listed in parentheses.

- Default Language (*English*)
- Default Units (*Imperial*)
- Default Workout Length (*30 minutes*)
- Pause Screen Timer (*60 seconds*)
- Program Timeout (*30 seconds*)
- Workout Duration Limit (*Basic*)
- Duration Limit (*60 minutes*)
- Marathon Mode (*Off*)
- Max Speed (*14 mph for INTDX and INTSX; 12 mph for Club Series*)
- Min Speed (*0.5 mph*)
- Max Incline (*15% for INTDX and Club Series; 10% for INTSX*)
- Display Inactivity Dimmer (*On*)
- System Sounds (*On*)
- Telemetry (*On*)
- Fitness Tests (*On*)
- Brightness (*70%*)
- Screen Saver Timeout (*5 min*)
- Enable Log In (*On*)
- Accept Touchscreen Calibration
- Restore Default Settings

4. **Exit** the Settings Menu.

PREVENTIVE MAINTENANCE TIPS

Life Fitness products are backed by the engineering excellence and reliability of Life Fitness and are one of the most rugged and trouble-free pieces of exercise equipment on the market today.

Note: *Safety of the equipment can be maintained only if the equipment is examined regularly for damage or wear. Keep the equipment out of use until defective parts are repaired or replaced.*

REMARQUE: *pour conserver un matériel sûr, il convient de l'inspecter régulièrement afin de déceler tout signe d'usure ou d'endommagement. N'utilisez pas l'appareil tant que les pièces défectueuses n'ont pas été réparées ou remplacées.*

The following preventive maintenance tips will keep the Life Fitness product operating at peak performance:

- Locate the product in a cool, dry place.
- Clean the display console and all exterior surfaces with an approved or compatible cleaner (see *Life Fitness Approved Cleaners*) and a microfiber cloth.
- Long fingernails may damage or scratch the surface of the console; use the pad of the finger to press the selection buttons on the console.

Life Fitness Approved Cleaners *(United States Availability Only)*

Two preferred cleaners have been approved by Life Fitness reliability experts: PureGreen 24 and Gym Wipes. Both cleaners will safely and effectively remove dirt, grime and sweat from equipment. PureGreen 24 and the Antibacterial Force formula of Gym Wipes are both disinfectants that are effective against MRSA and H1N1. PureGreen 24 is available in a spray which is convenient for gym staff to use. Apply the spray to a microfiber cloth and wipe down the equipment. Use PureGreen 24 on the equipment for at least 2 minutes for general disinfection purposes and at least 10 minutes for fungus and viral control. Gym Wipes are large, durable pre-moistened wipes to use on the equipment before and after workouts. Use Gym Wipes on the equipment for at least 2 minutes for general disinfection purposes.

Contact Customer Support Services to order these cleaners (1-800-351-3737 or email: customersupport@lifefitness.com).

Life Fitness Compatible Cleaners

Mild soap and water or a mild non-abrasive household cleaner can also be used to clean the display and all exterior surfaces. Use a soft microfiber cloth only. Apply the cleaner to the microfiber cloth before cleaning. **DO NOT** use ammonia or acid based cleaners. **DO NOT** use abrasive cleaners. **DO NOT** use paper towels. **DO NOT** apply cleaners directly to the equipment surfaces.

TROUBLESHOOTING

Malfunction	Probable Cause	Corrective Action
No Power.	Power source is insufficient	Using a voltmeter, verify power at outlet. If no power exists, reset circuit breaker at panel.
	Line cord is damaged.	Replace line cord. Contact Life Fitness Customer Support Services.
	Line cord is improperly seated in socket.	Inspect power connection at wall outlet and at machine for proper contact.
	Club Series Units Only: You may be in "Energy Saving Mode".	The unit will enter Energy Saving Mode after 5 minutes of inactivity, with a warning at 4:45 that energy saving is about to start. To wake the console, step on the treadmill or push the green "Go" button. When successful, a beep will be heard and the LCD screen will show the Life Fitness logo. The unit will take approximately 25 seconds to allow you to start a workout.
Display does not illuminate when machine is powered on.	Loose connection at display console or motor control board.	Check all electrical connections for proper attachment. Contact Life Fitness Customer Support Services.
Treadmill striding belt slips off-center.	Floor surface is uneven.	Check levelers and level treadmill. Check striding belt & re-tension as necessary. Refer to <i>Integrity Treadmill Assembly Instructions</i> .
Maximum treadmill speed is reduced.	User is pushing striding belt. This occurs when the runner is running faster than the striding belt will travel, with the result of the striding belt being pushed with the runner's feet.	Instruct users not to push striding belt in either direction.
	User is stalling striding belt. This will occur with heavier users at lower striding belt speeds. The striding belt will "stall" if the user is traveling slower than the striding belt speed.	
	Striding belt/deck malfunctions. The deck laminate is worn through or the underside of striding belt is glazed over (hard, glossy).	Replace belt and deck. Contact Life Fitness Customer Support Services.
	Power source is insufficient.	Plug treadmill into a dedicated 20 amp circuit.
Rubbing sound comes from underneath treadmill.	Foreign objects may be stuck underneath the machine.	Inspect underneath striding belt and machine. Remove any debris or objects that may cause interference with the treadmill.
Display does not illuminate when machine is powered on.	Loose connection at display console or motor control board.	Check all electrical connections for proper attachment. Contact Life Fitness Customer Support Services.

TROUBLESHOOTING - HEART RATE READING

Malfunction	Probable Cause	Corrective Action
Heart rate reading is initially detected and functioning normally but then is lost.	Use of personal electronic devices, such as cell phones and portable MP3 players, causes external noise interference.	Remove the source of noise or reposition the exercise equipment.
	Equipment is in close proximity to other sources of noise such as audio/video equipment, fans, two way radios, and high voltage/ high current power lines.	
Heart rate readings are abnormally elevated.	Television sets and/or antennas, cell phones, computers, cars, high voltage power lines, motor driven exercise equipment, and another heart rate transmitter within 3 ft. (0.9 m) generate electromagnetic interference.	Move the product a few inches away from the probable cause, or move the probable cause a few inches away from the product, until the heart rate readings are accurate.
Heart rate reading is erratic or absent entirely.	Belt transmitter electrodes are not wet enough to pick up accurate heart rate readings.	Wet the belt transmitter electrodes (see <i>The Optional Polar® Telemetry Heart Rate Chest Strap</i>).
	Belt transmitter electrodes are not laying flat against the skin.	Ensure the belt transmitter electrodes are laying flat against the skin (see <i>The Optional Polar® Telemetry Heart Rate Chest Strap</i>).
	Belt transmitter needs cleaning.	Wash the belt transmitter with mild soap and water.
	Belt transmitter is not within 3 ft. (0.9 m) of the heart rate receiver.	Make sure the chest strap transmitter is within 3 ft. (0.9 m) of the heart rate receiver.
	Polar telemetry heart rate chest strap battery is depleted.	Contact Life Fitness Customer Support Services for instructions on how to have the Polar telemetry heart rate chest strap replaced.
	Polar telemetry heart rate chest strap did not lock in with the heart rate receiver.	<p>Make sure the Polar telemetry heart rate chest strap is properly attached to the user's chest and move closer to the heart rate receiver inside the console. Wait up to 10 seconds for the heart rate to display on the console. The overall range of the heart rate strap is approximately 3 ft. (0.9 m) after it communicates with the receiver. The strap must be 1.5 - 2 ft. (0.5 - 0.6 m) away from the receiver in order to start communicating. When the display shows a heart rate value stay within 3 ft. (0.9 m).</p> <p>Notes:</p> <ol style="list-style-type: none"> 1. Ensure proper adherence of the Polar telemetry heart rate chest strap to user's chest. 2. Ensure proper conductivity between the electrodes and user's chest. 3. If needed, use the Polar watch to verify chest strap's operation.

INTEGRITY X CONSOLE SPECIFICATIONS

Display:	7" LCD color touch screen
Ambient Temperature Range: (Operating)	0°C to +40°C@ 90% RH (non-condensing)
Storage and Shipping Temperature Range:	-40°C to 75°C
Heart Rate Monitoring Systems:	Patented Lifepulse™ digital contact heart rate and Polar® telemetry-compatible heart rate monitoring system
Mobile Device Compatibility:	Bluetooth proximity, NFC
USB Device Charging:	Can be used in combination with Apple 30-pin, Apple Lightning and Android micro-USB cables to charge compatible devices.

Workouts:

<i>INTSX, INTDX & Club Series Treadmills</i>	Quick Start, Time Goal, Distance Goal, Calories Goal, Heart Rate Goal, Random, Manual, Hill, Rolling Hills, Speed Interval, Incline Interval, Life Fitness Fit Test
--	---

	Physical Dimensions				Shipping Dimensions			
	<i>Depth</i>	<i>Width</i>	<i>Height</i>	<i>Weight</i>	<i>Depth</i>	<i>Width</i>	<i>Height</i>	<i>Weight</i>
Integrity X Console	3.8 in. (96 mm)	20 in. (497 mm)	15 in. (390 mm)	6.75 lbs. (3.1 kg)	6.5 in. (165 mm)	24 in. (613 mm)	18 in. (463 mm)	10.8 lbs. 4.9 (kg)

© 2017 Life Fitness, A division of Brunswick Corporation. All Rights Reserved. Life Fitness is a registered trademark of Brunswick Corporation. Heart Rate+, LFconnect and Lifepulse are trademarks of Brunswick Corporation.

iPad, iPhone and iPod are registered trademarks of Apple Inc. Android is a trademark of Google Inc. PM-038-13. (3.14). Bluetooth is a registered trademark of Bluetooth SIG, Inc. FitLinxx is a trademark of FitLinxx, Inc. Gym Wipes® is a registered trademark of The 2XL Corporation. Polar is a registered trademark of Polar Electro, Inc. PureGreen 24 is a trademark of Pure Green.

WARRANTY INFORMATION

WHAT IS COVERED.

This LIFE FITNESS commercial exercise equipment ("Product") is warranted to be free of all defects in material and workmanship.

WHO IS COVERED.

The original purchaser or any person receiving a newly purchased Product as a gift from the original purchaser. Warranty will be voided on subsequent transfers.

HOW LONG IS IT COVERED.

All coverage is provided by specific Product according to the guidelines listed on the chart on the following page.

WHO PAYS TRANSPORTATION & INSURANCE FOR SERVICE.

If the Product or any covered part must be returned to a service facility for repairs, We, LIFE FITNESS, will pay all transportation and insurance charges for the first year. You are responsible for transportation and insurance charges during the second and third years (if applicable).

WHAT WE WILL DO TO CORRECT COVERED DEFECTS.

We will ship to you any new or rebuilt replacement part or component, or, at our option, replace the Product. Such replacement parts are warranted for the remaining portion of the original warranty period.

WHAT IS NOT COVERED.

Any failures or damage caused by unauthorized service, misuse, accident, negligence, improper assembly or installation, debris resulting from any construction activities in the Product's environment, rust or corrosion as a result of the Product's location, alterations or modifications without our written authorization or by failure on your part to use, operate and maintain the Product as set out in your Operation Manual ("Manual").

One type RJ45 interchangeable Network ready and Fitness Entertainment port is supplied with the Product. This port complies with the FitLinxx CSAFE specification dated August 4, 2004 stating: 4.75VDC to 10VDC; maximum current of 85mA. Any Product damage caused by a load exceeding this FitLinxx CSAFE specification is not covered by warranty.

All terms of this warranty are void if this product is moved beyond the continental borders of the United States of America (excluding Alaska, Hawaii and Canada) and are then subject to the terms provided by that country's local authorized LIFE FITNESS representative.

WHAT YOU MUST DO.

Retain proof of purchase; use, operate and maintain the Product as specified in the Manual; notify Customer Support Services of any defect within 10 days after discovery of the defect; if instructed, return any defective part for replacement or, if necessary, the entire Product for repair.

OPERATION MANUAL: It is VERY IMPORTANT THAT YOU READ THE MANUAL before operating the Product. Remember to perform the periodic maintenance requirements specified in the Manual to assure proper operation and your continued satisfaction.

HOW TO GET REPLACEMENT PARTS & SERVICE.

Refer to page one of this manual for your local service contact information. Reference your name, address and the serial number of your Product (*consoles and frames may have separate serial numbers*). They will tell you how to get a replacement part, or, if necessary, arrange for service where your Product is located.

EXCLUSIVE WARRANTY.

THIS LIMITED WARRANTY IS IN LIEU OF ALL OTHER WARRANTIES OF ANY KIND EITHER EXPRESSED OR IMPLIED, INCLUDING BUT NOT LIMITED TO THE IMPLIED WARRANTIES OF MERCHANTABILITY AND FITNESS FOR A PARTICULAR PURPOSE, AND ALL OTHER OBLIGATIONS OR LIABILITIES ON OUR PART. We neither assume nor authorize any person to assure for us any other obligation or liability concerning the sale of this Product. Under no circumstances shall we be liable under this warranty, or otherwise, of any damage to any person or property, including any lost profits or lost savings, for any special, indirect, secondary, incidental or consequential damages of any nature arising out of the use of or inability to use this Product. Some states do not allow the exclusion or limitation of implied warranties or of liability for incidental or consequential damages, so the above limitations or exclusions may not apply to you. Warranty coverages and terms may differ outside the United States. Please contact the Life Fitness office servicing your country (contact information found at the front of this manual) or visit the applicable local Life Fitness website to receive the specific warranty information for your country.

CHANGES IN WARRANTY NOT AUTHORIZED.

No one is authorized to change, modify or extend the terms of this limited warranty.

EFFECT OF STATE LAWS.

This warranty gives you specific legal rights and you may have other rights which vary from state to state and country by country.

WARRANTY INFORMATION

	Lifetime	10 Years	7 Years	3 Years	2 Years	1 Year	6 Months
Commercial Integrity X Console					Electrical & Mechanical Parts	Labor	Cosmetic Items
Consumer Integrity X Console (Home Use)				Electrical & Mechanical Parts		Labor	Cosmetic Items
Treadmill (INTDX, INTSX)			Frame, Lifespring™ Shock Absorbers, & Motor		Electrical Components	Mechanical Components & Labor	
Club Series Treadmill	Motor & Frame	Electrical & Mechanical Parts				Labor	

Warranties outside the U.S. may vary.