

**Nautilus<sup>®</sup> Instinct<sup>®</sup>**  
**OLYMPIC BENCHES**

- Olympic Flat Bench
- Olympic Incline Bench

---

**OWNER'S MANUAL**



# TABLE OF CONTENTS

<b>Introduction .....</b>	<b>4</b>
About This Manual .....	5
<b>Safety Instructions .....</b>	<b>5</b>
<b>Assembly and Setup - Olympic Flat Bench.....</b>	<b>6</b>
Parts and Materials .....	6
Siting Requirements .....	6
Unpacking .....	6
Assembly.....	7
Anchoring .....	8
<b>Assembly and Setup - Olympic Incline Bench.....</b>	<b>9</b>
Parts and Materials .....	9
Siting Requirements .....	9
Unpacking .....	9
Assembly.....	10
Anchoring .....	12
<b>Exercise Guidelines .....</b>	<b>13</b>
General Guidelines.....	13
Product Use and Maintenance .....	13
<b>Preventive Maintenance.....</b>	<b>14</b>
Maintenance Schedule .....	14
Maintenance Procedures.....	14
<b>Labels and Placards.....</b>	<b>15</b>
<b>Warranty and Disclaimer .....</b>	<b>16</b>

Copyright 2016. Core Health and Fitness, LLC. All rights reserved, including those to reproduce this book or parts thereof in any form without first obtaining written permission from Core Health and Fitness, LLC.

Every effort has been made to keep this information current; however, periodically, changes are made to the information herein, and these changes will be incorporated into new editions of this publication. All product names and logos are trademarks of their respective owners.



**Olympic Flat Bench**



**Olympic Incline Bench**

# INTRODUCTION

Thank you for choosing the *NAUTILUS INSTINCT OLYMPIC BENCH*. These units have been designed to provide the user the most rewarding experience based upon the carefully planned features it possesses. The design elements of this product will provide you with a comfortable, intuitive, safe and reliable experience, guiding you to a habit-forming lifestyle. Our mission is to provide products to mold lifelong habits for health and fitness, and the *INSTINCT OLYMPIC BENCH* will provide the path to meet your goals.

## ABOUT THIS MANUAL

This manual is applicable to the *INSTINCT OLYMPIC BENCH*. The manual is divided into eight sections, as follows:

### **Introduction**

Provides an overview of each section within the manual.

### **Safety Instructions**

Provides guidelines for safely operating the *INSTINCT OLYMPIC BENCH*.

### **Assembly and Setup**

Provides instructions for unpacking, assembling and setting up the *INSTINCT OLYMPIC BENCH*.

### **Exercise Guidelines**

Provides general guidelines to be followed when using the *INSTINCT OLYMPIC BENCH*.

### **Preventative Maintenance**

Describes the preventative maintenance measures required to keep the *INSTINCT OLYMPIC BENCH* in top condition.

### **Labels and Placards**

Provides illustrations and part number information for labels and placards used on *NAUTILUS INSTINCT* products.

### **Regulatory Information**

Provides warranty and servicing information for the *INSTINCT OLYMPIC BENCH*.

# SAFETY INSTRUCTIONS

Read this Owner's Manual carefully before assembling, servicing or using your *NAUTILUS INSTINCT OLYMPIC BENCH*.

**WARNING: SERIOUS INJURY MAY OCCUR IF THESE SAFETY PRECAUTIONS ARE NOT OBSERVED. UNDERSTANDING EACH AND EVERY WARNING TO THE FULLEST IS IMPORTANT. IF ANY OF THESE WARNINGS ARE UNCLEAR, CONTACT NAUTILUS PRODUCT SUPPORT FOR CLARIFICATION.**

1. Do not use any equipment in any way other than designed or intended by the manufacturer. It is imperative that weight stack machines as well as any other *NAUTILUS INSTINCT* equipment is used properly to avoid injury.
2. Make sure there is enough room for safe access and operation of the *INSTINCT OLYMPIC BENCH*.
3. Keep hands, feet, head, limbs, fingers and hair clear at all times from moving parts to avoid injury. Use appropriate positioning, speed and controlled movements.
4. DO NOT use any equipment that is damaged and or has worn or broken parts. Use only replacement parts supplied by *NAUTILUS*.
5. DO NOT wear loose or dangling clothing while using the *INSTINCT OLYMPIC BENCH*. Keep away from all moving parts.
6. Obtain a medical examination prior to beginning an exercise program.
7. If at any time during exercise you feel faint, dizzy or experience pain, STOP IMMEDIATELY and consult your physician before continuing.
8. Children must NOT be allowed to operate the *INSTINCT OLYMPIC BENCH*. Adolescents must be supervised when using the *INSTINCT OLYMPIC BENCH*.
9. DO NOT attempt to fix a broken or jammed unit. Notify authorized personnel.
10. Use the *INSTINCT OLYMPIC BENCH* only for the intended use. Obtain instruction on proper use of the unit. It is the purchaser's sole responsibility to properly instruct end users and supervising personnel as to the proper operating procedures of all *NAUTILUS INSTINCT* equipment. DO NOT modify the unit.
11. Load plates evenly and carefully to avoid tipping equipment and possible crushing injuries.
12. DO NOT use the *INSTINCT OLYMPIC BENCH* if guards or shrouds are missing or damaged.
13. USE A SPOTTER.
14. DO NOT add incremental weights, except those provided by *NAUTILUS*.
15. MAINTAIN PLACARDS AND LABELS: Do not remove labels for any reason; they contain important information. If illegible or missing, contact the *NAUTILUS* Parts Department for replacement.
16. SECURING EQUIPMENT: The *INSTINCT OLYMPIC BENCH* MUST be secured to the floor to stabilize and eliminate rocking or tipping over. This must be performed by a licensed contractor. DO NOT use the UNIT if it is not set up and located on a solid level surface.
17. Make sure that each machine is set up and operated on a solid level surface. DO NOT install equipment on an uneven surface.
18. MAINTAIN ALL EQUIPMENT: Preventative maintenance is the key to ensuring smooth and reliable operation of the *INSTINCT OLYMPIC BENCH*, as well as keeping your liability to a minimum. Inspect the unit prior to use. Give particular attention to the areas most susceptible to wear. DO NOT use if the unit is damaged or inoperable.
19. Ensure that adjustment, maintenance and/or repair of the *INSTINCT OLYMPIC BENCH* is performed by qualified personnel ONLY. Immediately replace worn or damaged components. If unable to immediately replace worn or damaged components then remove the *INSTINCT OLYMPIC BENCH* from service until repairs are made.
20. Keep a repair log of all maintenance activities.
21. Routinely inspect all accessory clips that join attachments to weight belts or cables, and replace at the first sign of wear.
22. Use only weight selector pins supplied by *NAUTILUS* on weight stacks. Substitutes are forbidden.
23. Cables and belts pose an extreme liability if used when frayed. Always replace any cable or belt at first sign of wear (consult *NAUTILUS* Product Support if uncertain).
24. Fully insert the weight selector pin when selecting the desired weight. Partially inserted pins can cause weights to fall unexpectedly. NEVER remove the weight selector pin if any weights are suspended. NEVER attempt to release jammed weights or parts.
25. DO NOT use Lat Pulldown Bars on Multi-jungle Crossover cable systems or any other pulley systems. These bars are designed for lat pulldown machines ONLY. If improperly used, the Lat Bar could fall unexpectedly, striking the user when weight selector pin is removed.
26. Lat Pulldown Machines pose a danger if used with worn or damaged cables and connecting links. The user can be struck in the head if the cable or related parts break during use.
27. When adjusting any seat, knee hold down pad, range of motion limiter, foothold pad or any other type of adjuster, make certain that the adjusting pin is fully engaged in the retainer hole to avoid injury.

**NOTE:** *It is the sole responsibility of the user/owner or facility operator to ensure that regular maintenance is performed.*

# ASSEMBLY AND SETUP - OLYMPIC FLAT BENCH

## PARTS AND MATERIALS

The following parts are included with the *NAUTILUS INSTINCT OLYMPIC FLAT BENCH*:

1	Frame, Right Side	1	11	Screw, Flat Head Socket, 10X75M	6
2	Frame, Left Side	1	12	Screw, Button Head Socket Cap, 10X20M	6
3	Crossbeam	1	13	Screw, Button Head Socket Cap, 10X30M	5
4	Frame, Bench	1	14	Screw, Button Head Socket Cap, 10X80M	2
5	Cushion, Bench	1	15	Screw, Button Head Socket Cap, 10X130M	4
6	Support Tube, Weight	6	16	Lock Nut, Nylon Insert, 10M	12
7	Support, Barbell	2	17	Washer, 11M	17
8	End Cap, Weight Support Tube	6	18	Washer, 11M	6
9	Pad, Frame	5	21	Bracket, Support, Head	1
10	Grommet, Weight Support Tube	6			

## TOOLS REQUIRED

Most *NAUTILUS INSTINCT* machines can be assembled using the following tools:

- Metric Hex Key Wrenches - 2.5mm, 5mm, 6mm, 8mm, 10mm
- Metric Open-End Wrenches - 10mm, 15mm, 17mm
- Metric Ratchet Socket Wrench Set (including 17mm socket)
- Torque Wrench
- Channel Lock Pliers
- Vice Grip Pliers
- Rubber Mallet
- Phillips Head Screwdriver - #2

Your *INSTINCT OLYMPIC FLAT BENCH* includes a hex key set and combination open-end wrench.

## SITING REQUIREMENTS

Your *INSTINCT OLYMPIC FLAT BENCH* requires approximately \_\_ square feet of floor space to ensure safe use of the unit.

## UNPACKING

Your *INSTINCT OLYMPIC FLAT BENCH* is shipped in one or more shipping cartons. Each carton will generally contain one subassembly of the entire unit. To unpack:

- Remove the shipping straps from the outside of each shipping carton.
- Open the top of each carton and fold back all four flaps.
- Remove the packing materials, foam inserts, and ALL parts from each shipping carton. Keep the contents of each carton in a *separate area* to facilitate assembly. To ensure personal safety during assembly, place all packing materials *outside* the assembly area.
- Verify that all parts listed above are included in your shipment.

Take time now to enter your *INSTINCT OLYMPIC FLAT BENCH* serial number in the space below. If parts are missing, or if you have any operational questions, please call Nautilus's Service department at (800) 503-1221; have your serial number ready.

Serial No. \_\_\_\_\_

# ASSEMBLY

## 1. Assemble the Side Frames

Install one frame pad (9) onto each foot of the right side frame (1). Be sure the frame pads are properly seated on the frame, and the retaining lips on the end of each pad engage the foot to secure.

Install three weight support tubes (6) onto the weight shafts on the right side frame (1). Secure each support tube to the frame using one screw (12) and washer (17). Tighten the screws securely.

Press one end cap (8) into the end of each weight support tube (6). If needed, use a rubber mallet to tap the caps into place.

Install one rubber grommet (10) onto each weight support tube (6), and slide back on the tube until the grommet contacts the right side frame (1).

Align the three drilled holes in one barbell support (7) with the mating holes in the right side frame (1). Secure the support to the frame using three screws (11), washers (18) and lock nuts (16). Tighten the nuts securely.

Assemble the left side frame (2) in a similar manner.

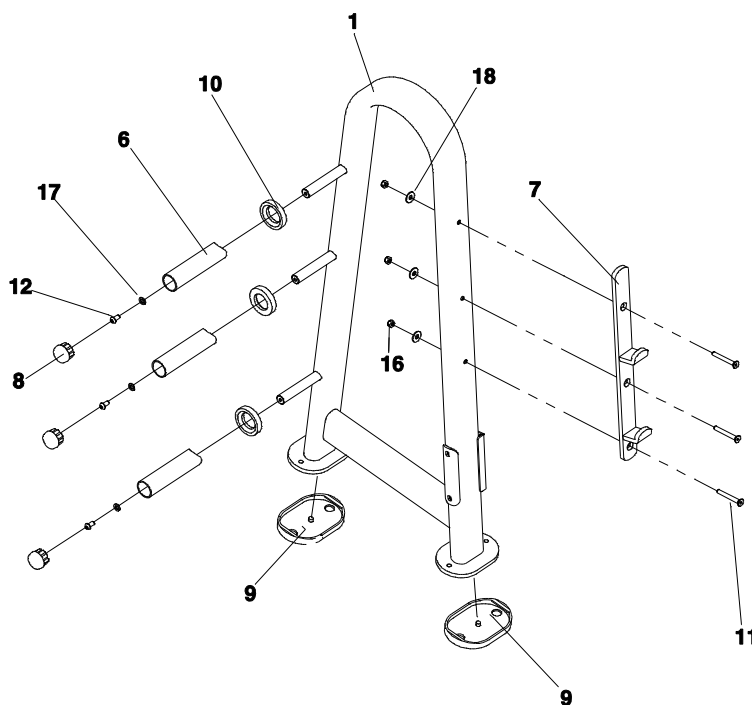

## 2. Assemble the Bench Frame

Install one frame pad (9) onto the foot of the bench frame (4). Be sure the frame pads are properly seated on the frame, and the retaining lips on the end of each pad engage the foot to secure.

Align the two drilled holes in the crossbeam (3) with the mating holes in the bench frame (4). Insert two screws (14) through the bench frame to maintain the parts in position. Slide the head support bracket (21) onto the two screws (14), and secure the frame, crossbeam and support bracket together using two washers (17) and lock nuts (16). Tighten the nuts securely.

Hold the bench cushion (5) in place on the bench frame (4). Secure the bench cushion to the bench frame with five screws (13) and washers (17). Tighten the screws securely.

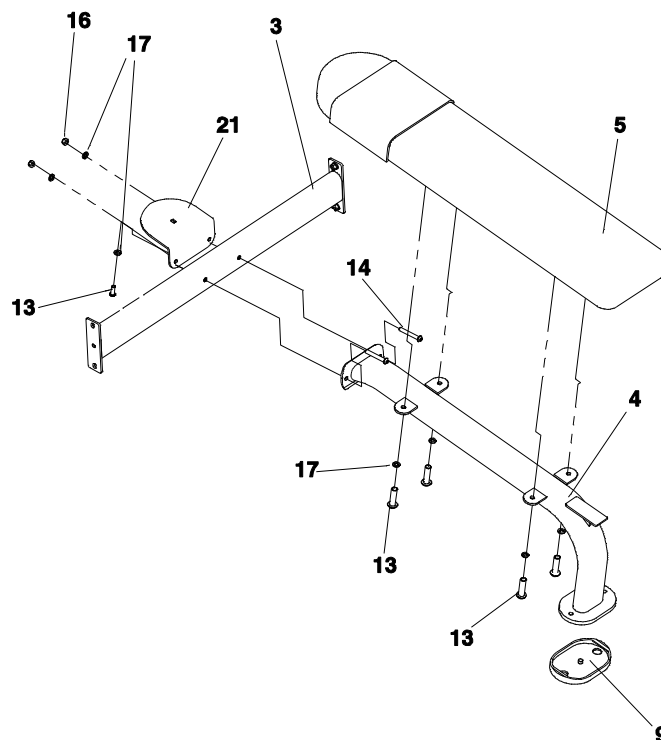

### 3. Assemble the Bench

Align the two drilled holes in the crossbeam (3) with the mating holes in the right side frame (1). Secure the crossbeam to the frame using two screws (15), washers (17) and lock nuts (16). Tighten the nuts securely.

Align the two drilled holes in the crossbeam (3) with the mating holes in the left side frame (2). Secure the crossbeam to the frame using two screws (15), washers (17) and lock nuts (16). Tighten the nuts securely.

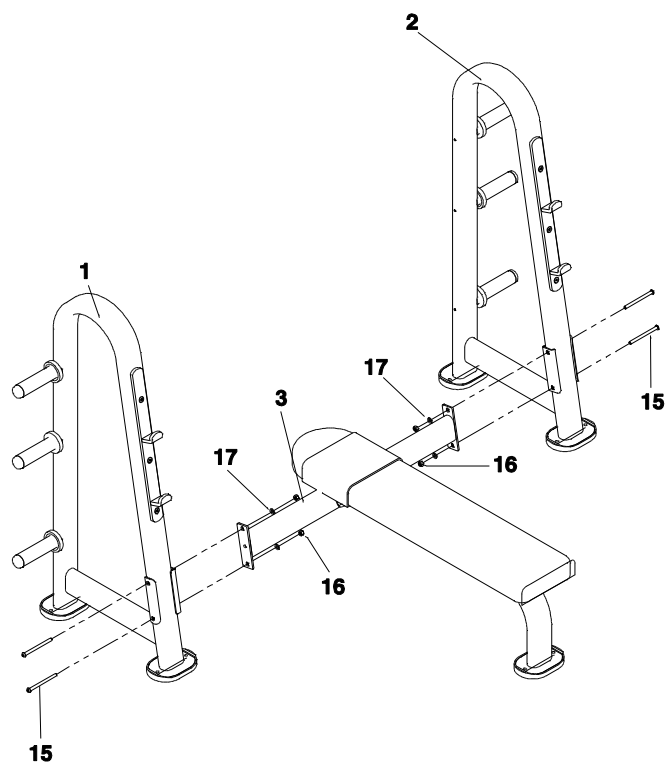

### 4. Final Assembly and Testing

Check all attaching parts to ensure they are tightened securely.

You have now completed assembly of your **INSTINCT OLYMPIC FLAT BENCH**.

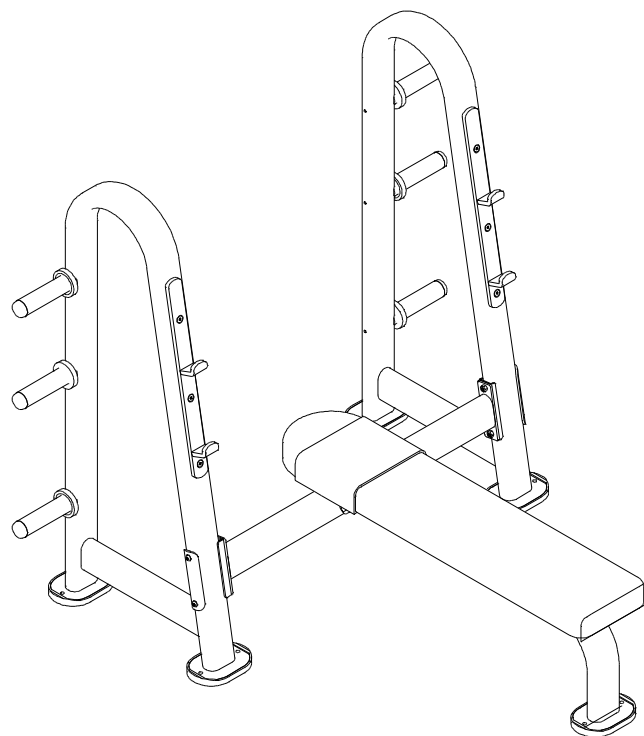

## ANCHORING

**IMPORTANT:** The **INSTINCT OLYMPIC FLAT BENCH** must be secured to the floor to stabilize and eliminate rocking or tipping over. This must be performed by a licensed contractor. Failure to anchor the unit will void the warranty. NAUTILUS shall not be liable for damage or injury caused by unanchored or improperly anchored units.



The **INSTINCT OLYMPIC FLAT BENCH** must be anchored to the floor using through bolts or anchoring studs. Each foot pad on the unit provides two anchoring holes that will accommodate bolts of up to 12mm (7/16") diameter. Only one hole in each foot pad is required during anchoring. The holes used for anchoring may be selected based on installation site requirements or customer preference.

Anchoring bolts/studs must meet the following requirements:

- Anchor bolts shall be Grade 8.8 or Grade SAE 5.
- Anchoring bolts or studs shall have a minimum size of 6mm (1/4") diameter; 8mm (5/16") diameter bolts/studs are recommended.
- Pull-out force shall be 100kg (2201 lbs) minimum for any single anchor. This will ensure a secure anchoring system and safe operation of the unit by all users.

## ASSEMBLY AND SETUP - OLYMPIC INCLINE BENCH

### PARTS AND MATERIALS

The following parts are included with the **NAUTILUS INSTINCT OLYMPIC INCLINE BENCH**:

1	Frame, Right Side	1	19	Cushion, Bench	1
2	Frame, Left Side	1	20	Cushion, Seat	1
3	Crossbeam	1	23	Screw, Flat Head Socket, 10X75M	6
4	Frame, Bench	1	24	Screw, Button Head Socket Cap, 10X20M	6
5	Post, Seat	1	25	Screw, Button Head Socket Cap, 10X30M	4
6	Handle, Ratchet (factory-installed)	1	26	Screw, Button Head Socket Cap, 10X40M	2
7	Support, Footrest	1	27	Screw, Button Head Socket Cap, 10X70M	2
9	Footrest	1	28	Screw, Button Head Socket Cap, 10X80M	6
10	Support, Barbell	2	29	Screw, Button Head Socket Cap, 10X130M	4
11	Support Tube, Weight	6	32	Lock Nut, Nylon Insert, 10M	16
13	End Cap, Weight Support Tube	6	34	Washer, 11M	22
16	Grommet, Weight Support Tube	6	35	Washer, 11M	8

### TOOLS REQUIRED

Most **NAUTILUS INSTINCT** machines can be assembled using the following tools:

- Metric Hex Key Wrenches - 2.5mm, 5mm, 6mm, 8mm, 10mm
- Metric Open-End Wrenches - 10mm, 15mm, 17mm
- Metric Ratchet Socket Wrench Set (including 17mm socket)
- Torque Wrench
- Channel Lock Pliers
- Vice Grip Pliers
- Rubber Mallet
- Phillips Head Screwdriver - #2

Your **INSTINCT OLYMPIC INCLINE BENCH** includes a hex key set and combination open-end wrench.

### SITING REQUIREMENTS

Your **INSTINCT OLYMPIC INCLINE BENCH** requires approximately \_\_ square feet of floor space to ensure safe use of the unit.

### UNPACKING

Your **INSTINCT OLYMPIC INCLINE BENCH** is shipped in one or more shipping cartons. Each carton will generally contain one subassembly of the entire unit. To unpack:

- Remove the shipping straps from the outside of each shipping carton.
- Open the top of each carton and fold back all four flaps.
- Remove the packing materials, foam inserts, and ALL parts from each shipping carton. Keep the contents of each carton in a *separate area* to facilitate assembly. To ensure personal safety during assembly, place all packing materials *outside* the assembly area.

- Verify that all parts listed above are included in your shipment.

Take time now to enter your **INSTINCT OLYMPIC INCLINE BENCH** serial number in the space below. If parts are missing, or if you have any operational questions, please call Nautilus's Service department at (800) 503-1221; have your serial number ready.

Serial No. \_\_\_\_\_

## ASSEMBLY

### 1. Assemble the Side Frames

Install three weight support tubes (11) onto the weight shafts on the right side frame (1). Secure each support tube to the frame using one screw (24) and washer (34). Tighten the screws securely.

Press one end cap (13) into the end of each weight support tube (6). If needed, use a rubber mallet to tap the caps into place.

Install one rubber grommet (16) onto each weight support tube (6), and slide back on the tube until the grommet contacts the right side frame (1).

Align the three drilled holes in one barbell support (10) with the mating holes in the right side frame (1). Secure the support to the frame using three screws (23), washers (34) and lock nuts (32). Tighten the nuts securely.

Assemble the left side frame (2) in a similar manner.

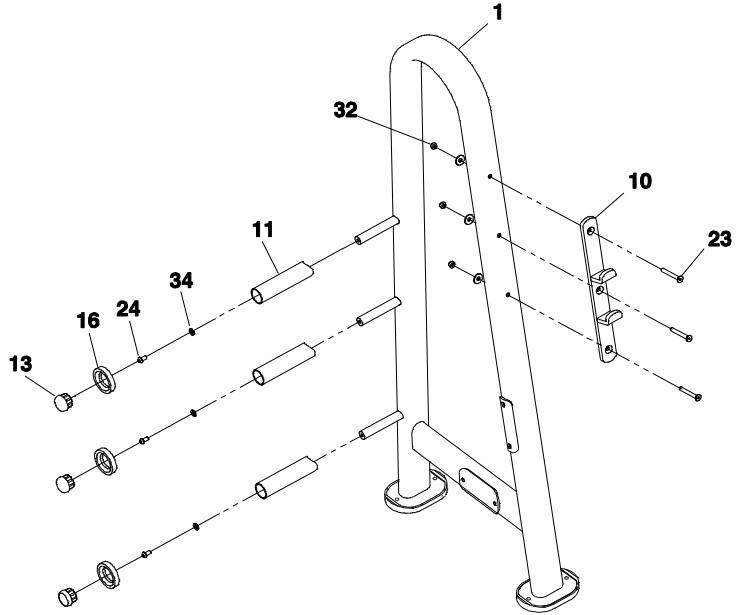

### 2. Assemble the Bench Frame

Align the two drilled holes in the crossbeam (3) with the mating holes in the bench frame (4). Secure the crossbeam to the frame using two screws (28), washers (34) and lock nuts (32). Tighten the nuts securely.

Hold the bench cushion (19) in place on the bench frame (4). Secure the bench cushion to the bench frame with four screws (25) and washers (34). Tighten the screws securely.

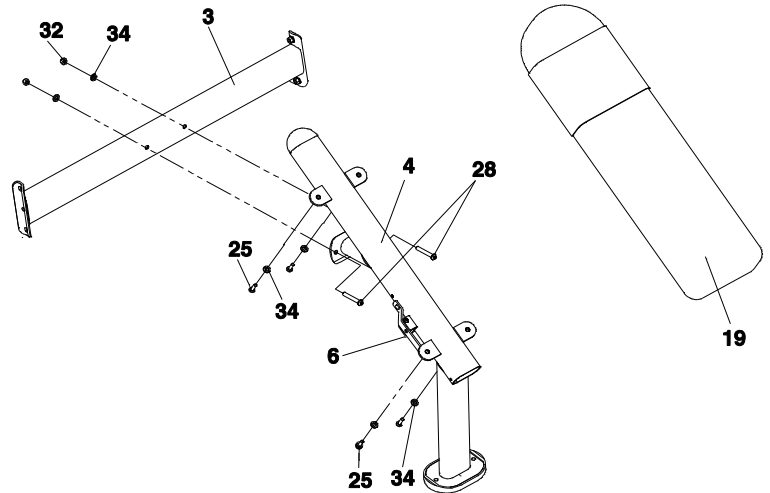

### 3. Assemble the Seat Post

Hold the seat cushion (20) in place on the seat post (5). Secure the seat cushion to the seat post with two screws (27) and washers (34). Tighten the screws securely.

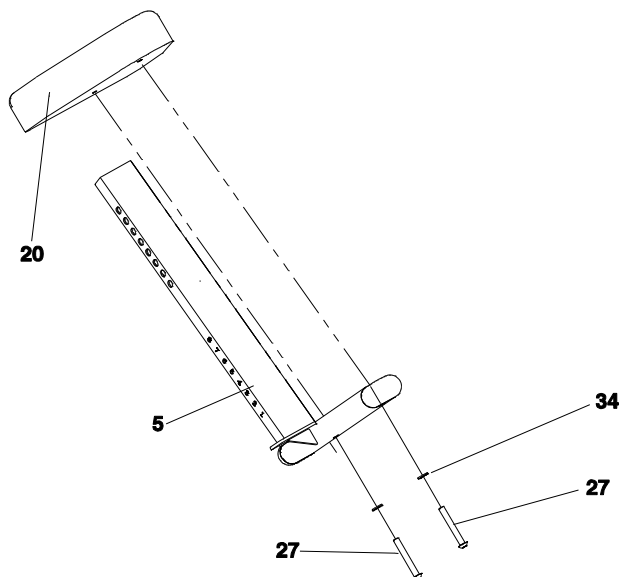

### 4. Install the Seat Post

Slowly slide the seat post (5) into the seat post guide in the bench frame (4). While holding the seat post, press the ratchet handle (6) to retract the locking pin, and slide the seat post fully into the seat post guide.

Release the ratchet handle. Slowly lower the seat post until the locking pin on the ratchet handle locks into a drilled hole in the seat post.

Install the seat post retaining screw (24) into the bottom of the seat post guide. Tighten the screw securely. While holding the seat post, press the ratchet handle (6) to retract the locking pin, and lower the seat post. Make sure the retaining screw prevents the seat post from falling out of the seat post guide.

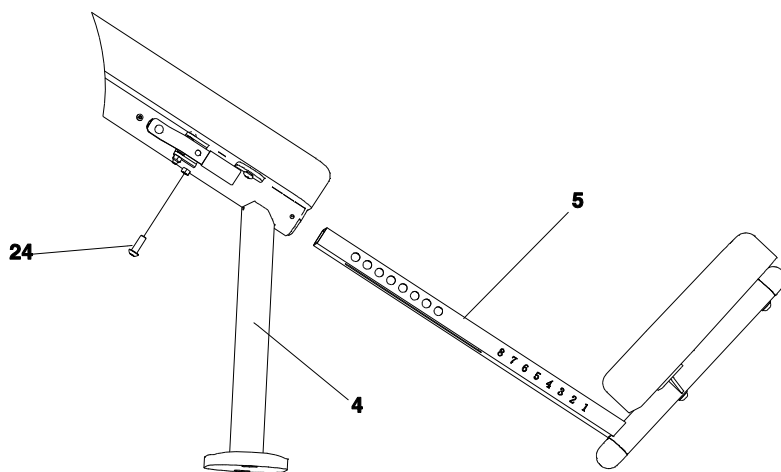

### 5. Assemble the Foot Rest

Align the two drilled holes in the footrest (9) with the mating holes in the footrest support (7). Secure the footrest to the support using two screws (26) and washers (35). Tighten the screws securely.

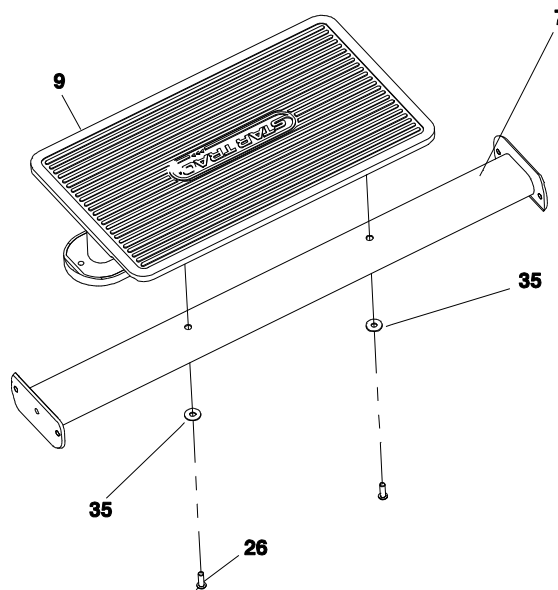

## 6. Assemble the Bench

Align the two drilled holes in the footrest support (7) with the mating holes in the right side frame (1). Secure the support to the frame using two screws (28), washers (34) and lock nuts (32). Tighten the nuts securely.

Align the two drilled holes in the crossbeam (3) with the mating holes in the right side frame (1). Secure the crossbeam to the frame using two screws (29), washers (34) and lock nuts (32). Tighten the nuts securely.

Align the two drilled holes in the footrest support (7) and the two drilled holes in the crossbeam (3) with the mating holes in the left side frame (2). Secure the footrest support to the frame using two screws (28), washers (34) and lock nuts (32). Tighten the nuts securely. Secure the crossbeam to the frame using two screws (29), washers (34) and lock nuts (32). Tighten the nuts securely.

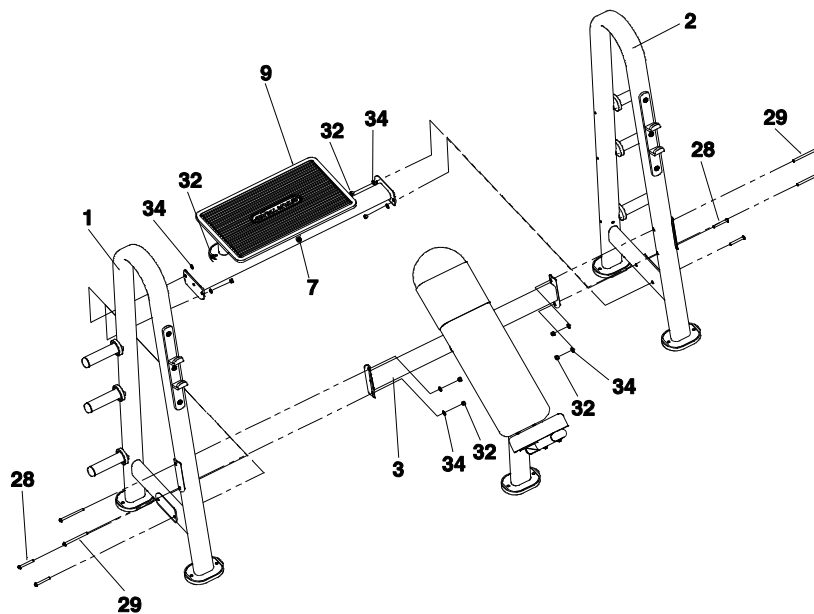

## 7. Final Assembly and Testing

Check all attaching parts to ensure they are tightened securely.

Verify operation of the seat post:

- Mount the unit. While holding the seat post, press the ratchet handle (6) to retract the locking pin, and lower the seat. Release the ratchet handle, and verify the locking pin engages the first drilled hole at the first seat position.
- Repeat to verify the locking pin engages the drilled hole at all seat positions.
- While holding the seat post, press and hold the ratchet handle and lower the seat post completely. Verify the retaining screw prevent the seat post from falling out of the seat post guide.
- Return the seat post to the "stowed" position.
- Verify the seat post slides smoothly, without evidence of sticking or binding.

You have now completed assembly of your **INSTINCT OLYMPIC INCLINE BENCH**.

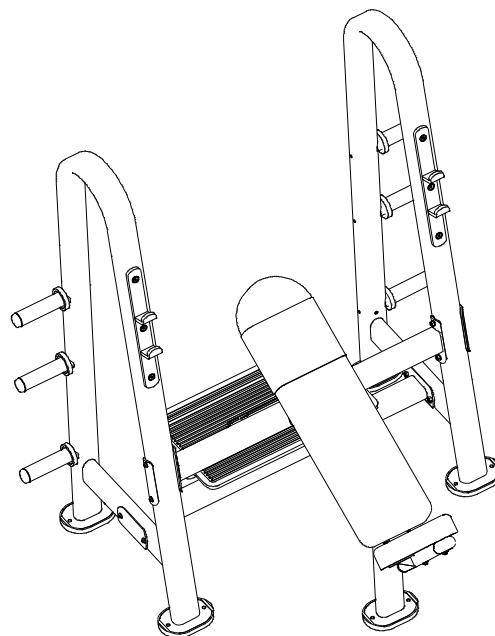

## ANCHORING

**IMPORTANT:** The **INSTINCT OLYMPIC INCLINE BENCH** must be secured to the floor to stabilize and eliminate rocking or tipping over. This must be performed by a licensed contractor. Failure to anchor the unit will void the warranty. NAUTILUS shall not be liable for damage or injury caused by unanchored or improperly anchored units.

The **INSTINCT OLYMPIC INCLINE BENCH** must be anchored to the floor using through bolts or anchoring studs. Each foot pad on the unit provides two anchoring holes that will accommodate bolts of up to 12mm (7/16") diameter. Only one hole in each foot pad is required during anchoring. The holes used for anchoring may be selected based on installation site requirements or customer preference.

Anchoring bolts/studs must meet the following requirements:

- Anchor bolts shall be Grade 8.8 or Grade SAE 5.
- Anchoring bolts or studs shall have a minimum size of 6mm (1/4") diameter; 8mm (5/16") diameter bolts/studs are recommended.
- Pull-out force shall be 100kg (2201 lbs) minimum for any single anchor. This will ensure a secure anchoring system and safe operation of the unit by all users.

## **EXERCISE GUIDELINES**

### **GENERAL GUIDELINES**

As with any exercise program, strength training involves an element of risk. The information provided in this section will help you and/or your members make safe and productive use of your **NAUTILUS INSTINCT OLYMPIC BENCH**.

- ALWAYS consult a physician before beginning any strength-training program. This is particularly important for persons with known health conditions and/or persons that are not familiar with the risks involved with weight training.
- All training sessions should be supervised by trained personnel.
- BE SURE that all warning labels and placards affixed to the **INSTINCT OLYMPIC BENCH** remain on the unit. DO NOT alter warning labels and placards. BE SURE that each user reads and understands the information shown on all labels and placards (safety, instructional and/or other).
- Instruct all users on the proper use of the **INSTINCT OLYMPIC BENCH**, as well as those actions that should be avoided.
- Your **INSTINCT OLYMPIC INCLINE BENCH** has been designed to accommodate a wide variety of body types. Prior to use, mount the unit and adjust the seat height to ensure comfortable use of the unit.

To minimize user and/or bystander injury:

- Do not lean against framework.
- Exercising on free weight and selectorized products should be performed with the assistance of a spotter.

### **PRODUCT USE AND MAINTENANCE**

Repair of the **INSTINCT OLYMPIC BENCH** should be performed only by authorized persons.

NEVER modify the **INSTINCT OLYMPIC BENCH** or attempt to make adjustment(s) to, or the repair of, the unit equipment without first calling **NAUTILUS** Product Support. Always notify authorized personnel to make such repairs.

Instruct all users to report any equipment or training irregularities to supervisory personnel IMMEDIATELY.

# PREVENTIVE MAINTENANCE

## MAINTENANCE SCHEDULE

Nautilus strongly recommends performing regular preventive maintenance on your **NAUTILUS INSTINCT OLYMPIC BENCH**. Without regularly scheduled maintenance, normal wear and tear may cause cumulative effects, such as misalignment or premature wear, resulting in downtime. For this reason, we highly recommend following the maintenance schedules. Additionally, unusual symptoms, such as excessive noise during use, stiffness or free play in moving parts, etc., should be investigated and necessary corrective actions (adjustment or parts replacement) should be performed. If any components are found to be worn or damaged, the unit should be removed from service until repairs can be made. Only components supplied or approved by Nautilus shall be used to maintain and/or repair the unit.

### DAILY MAINTENANCE

- Wipe down and inspect the framework and other structural components (see **FRAMEWORK MAINTENANCE** on page 14 for requirements). Check all attaching hardware for security. Tighten as needed.
- Clean and inspect the upholstered cushions (see **UPHOLSTERY MAINTENANCE** on page 15 for requirements).

### WEEKLY MAINTENANCE

- Check all labels and placards affixed to the unit for legibility and security. Replace illegible labels and placards as needed (see **LABELS AND PLACARDS** on page 15 for illustrations and part numbers of standard labels and placards used on **NAUTILUS INSTINCT** products).

### QUARTERLY MAINTENANCE

- Apply wax to powder-coated areas of the framework and other structural components.

## MAINTENANCE PROCEDURES

### FRAMEWORK MAINTENANCE

**CAUTION:** DO NOT use lacquer thinner, acetone, or other solvents to clean powder-coated finishes on the framework or other structural components. Solvents will dull the finish, and contain components that may remove the epoxy-based powder from the frame.

Framework and other structural components should be wiped down on a daily basis using a moistened with water. This will increase the longevity of protective powder-coat finishes. The framework should be inspected while cleaning for evidence of fatigue cracks, scratches or chips in the finish, loose hardware, and other areas that may require attention.

Apply easy-application car wax to all powder-coated surfaces quarterly. Regular waxing will aid in preventing premature rusting due to corrosives found in perspiration, and will allow loose particles to be removed more easily when performing the daily wipe-down.

Procedures to repair scratches and chips depend on the severity of the damage:

- Surface scratches can generally be repaired by polishing with an automotive rubbing compound.
- Deep scratches and chips must be repaired by filling the damaged area using a “touch-up” bottle of color-matched paint (available through the **NAUTILUS** Parts Department). Fill the damaged area sparingly, using two or more coats. Allow the area to dry thoroughly between coats. Once the touch-up is complete, it can be left “as is”, or it can be blended and color-sanded to the surrounding surface.

**NOTE:** *The process of blending and sanding repaired areas to the surrounding surface is difficult. It should be attempted ONLY by persons knowledgeable in this area.*

## ***UPHOLSTERY MAINTENANCE***

**CAUTION:** DO NOT use cleaners such as Lysol®, Armor All®, Windex®, or other abrasive detergents to clean upholstered surfaces. These products will remove moisture from the Naugahyde® upholstery, resulting in premature cracking.

Upholstered cushions should be cleaned on a daily basis to prevent damaged due to corrosives found in perspiration.

Wipe the top and sides of upholstered cushions using a cloth moistened with a solution of one part lanolin hand cleaner to nine parts water. After cleaning, wipe down using a dry towel to remove any residue.

## ***LABELS AND PLACARDS***



# WARRANTY & DISCLAIMER

**NAUTILUS** warrants all frameworks for a period of 10 years. All moving parts are warranted for 1 year. 10 year limited warranty on structural frame not including coatings. 90 days on upholstery stitching only, cables and belts. Warranty is for parts only. Warranty is good and available to the original purchaser only as noted by **NAUTILUS** invoice and is not transferable nor assumable. **NAUTILUS** cannot warrant products that have been abused, neglected and or poorly maintained. All equipment should be reviewed at the time of delivery for damage, breakage, loosening of nuts and bolts, components and or any other moving parts. Any and all claims for warranty must be received in writing within 70 days of defect. Do not alter, modify or redesign any **NAUTILUS** products or use any replacement parts or materials other than those components original to **NAUTILUS** as it will limit the warranty and liability of **NAUTILUS**. **NAUTILUS** reserves the right to change, replace or modify products, parts, accessories and or design without notice. Deposits on cancelled orders will be subject to handling and restocking charges.

## WHAT IS COVERED

This **NAUTILUS INSTINCT OLYMPIC BENCH** is warranted to be free of all defects in material and workmanship.

## WHO IS COVERED

The original purchaser or any person receiving the Product as a gift from the original purchaser.

## WHO PAYS TRANSPORTATION & INSURANCE FOR SERVICE

If the Product or any covered part must be returned to a service facility for repairs, We, **NAUTILUS**, will pay all transportation and insurance charges for the first year. You are responsible for transportation and insurance charges for all subsequent years.

## WHAT WE WILL DO TO CORRECT COVERED DEFECTS

We will ship to you any new or rebuilt replacement part or component, or, at our option, replace the Product. Such replacement parts are warranted for the remaining portion of the original warranty period.

## WHAT IS NOT COVERED

Any failures or damage caused by unauthorized service, misuse, accident, negligence, improper assembly or installation, debris resulting from any construction activities in the Products environment, rust or corrosion as a result of the Product(s) location, alterations or modifications without our written authorization or by failure on your part to use, operate and maintain the Product as set out in your Owners Manual.

## OWNERS MANUAL

It is VERY IMPORTANT THAT YOU READ THIS MANUAL before operating the Product. Remember to perform the periodic maintenance requirements specified in the Manual to assure proper operation and your continued satisfaction.

## HOW TO GET PARTS & SERVICE

Simply call Customer Support Services at (800) 966-3539 or (951) 600-3800, Monday through Friday from 8:00 a.m. to 5:00 p.m. Pacific Standard Time, and tell them your name, address and the model number of your Product. They will tell you how to get a replacement part, or, if necessary, arrange for service where your Product is located or advise you on how and where to ship the Product for service. You can also contact us via Fax at (951) 600-1706 or e-mail us at

Before shipping:

1. Obtain a Return Authorization Number (RA#) from Customer Support Services
2. Securely pack your Product (use the original shipping carton, if possible)
3. Write the RA# on the outside of the carton
4. Insure the Product, and
5. Include a letter explaining the defect or problem and a copy of your proof of purchase if you believe the service is covered by warranty.

## EXCLUSIVE WARRANTY

THIS LIMITED WARRANTY IS IN LIEU OF ALL OTHER WARRANTIES OF ANY KIND EITHER EXPRESSED OR IMPLIED, INCLUDING BUT NOT LIMITED TO THE IMPLIED WARRANTIES OF MERCHANTABILITY AND FITNESS FOR A PARTICULAR PURPOSE, AND ALL OTHER OBLIGATIONS OR LIABILITIES ON OUR PART. We neither assume nor authorize any person to assure for us any other obligation or liability concerning the sale of this Product. Under no circumstances shall we be liable under this warranty, or otherwise, of any damage to any person or property, including any lost profits or lost savings, for any special, indirect, secondary, incidental or consequential damages of any nature arising out of the use of or inability to use this Product. Some states do not allow the exclusion or limitation of implied warranties or of liability for incidental or consequential damages, so the above limitations or exclusions may not apply to you.

## CHANGES IN WARRANTY NOT AUTHORIZED

No one is authorized to change, modify or extend the terms of this limited warranty.

## EFFECT OF STATE LAWS

This warranty gives you specific legal rights and you may have other rights, which vary, from state to state.

## OUR PLEDGE TO YOU

Our Products are designed and manufactured to the highest standards. **NAUTILUS** wants you completely satisfied with our Products and will do everything possible under the terms of this warranty to keep you secure in knowing you have bought the best!











MANUFACTURER

4400 NE 77<sup>th</sup> Avenue, Suite 300, Vancouver, WA 98662 USA

**Tel** +1 (888) 678-2476

[www.corehandf.com](http://www.corehandf.com)

CUSTOMER SUPPORT

Contact your local distributor, or Core Health & Fitness directly at:

**Tel** +1-800-503-1221

[www.support@corehandf.com](mailto:www.support@corehandf.com)

Part Number: 730-7235