

Jazzy[®] Elite 14

US

AGM# 088 609 661

Illustrated *P*arts *B*reakdown



Pride[®]

Your new Pride Illustrated Parts Breakdown (IPB) Manual has been compiled from the latest product information available at the time of publication. Pride[®] Mobility Products Corporation reserves the right to make changes and updates to this manual and to the product(s) it represents. Any changes, updates, or improvements to the product(s) may result in slight differences between this manual and the product you purchased.

An IPB is an illustrated parts listing of all product components which have maintenance significance. IPB's utilize "exploded" drawings to detail the individual components for each assembly and an itemized list of reference numbers, part numbers, descriptions, and quantities per assembly. Some parts may be included in an assembly but may not be available for purchase separately. Refer to the parts list to locate the part numbers for assemblies and components for ordering what you need.

To achieve proper identification and relationship of detail parts and next higher assemblies, parts listings are presented in a convenient alphanumeric reference system. Reference numbers for parent assemblies identify one part number that can be used to order all of the components listed within it. Components of an assembly will have the same alpha character as its parent assembly.

- For example, the parent assembly part number using reference number of A1 — A4 is the only number you need to place an order for parts with references of A1, A2, A3, and A4. Instead of ordering 4 separate parts, use the parent assembly part number to get the complete assembly.

Master assembly part numbers have reference numbers that include several subassemblies. By ordering parts using master assembly part numbers, you can save a lot of time and reduce the chance for error.

- For example, A1 — G10, a master assembly reference number, includes all components of assemblies A, B, C, D, E, F, and G. Use caution when ordering assemblies. Check to see if a master assembly part number exists for the components that you need. If an entire master assembly is not needed, then the individual assembly part number (i.e. for reference number G1 — G10) will be sufficient to use for ordering.

Asterisks (*) and NOTES are used throughout this service manual to point out important information regarding assembly structure and contents.

- For example, in some illustrations, only the left OR right side is shown. In other drawings, only the front OR back is depicted. The part numbers for ALL components are listed. An asterisk will also be used to indicate which components are not illustrated. Illustrated Items without callouts are shown for assembly purposes.

Updates to the contents of this IPB will be made on a regular basis. Providers may retrieve updates immediately upon their release by going to the Pride Service Website. The web address is www.prideprovider.com. We welcome any questions or comments regarding the new Pride IPB Manual that you may have.

Please note all pricing included with this manual is subject to change without prior notice from Pride.

Thank you for choosing products from Pride[®] Mobility Products Corporation.

SECTION I.
Frame Assembly 4
 Main 4
 Rear Caster 6

SECTION II.
Motor Assembly 8

SECTION III.
Electronics Assembly 10

SECTION IV.
Foot Platform Assembly 12

SECTION V.
Drive Wheel Assembly 13

SECTION VI.
Shroud Assembly 14

SECTION VII.
Seat Tower Assembly 16

SECTION VIII.
Controller Assembly 18

SECTION IX.
Charger Assembly 20

SECTION X.
Owner's and Decal Package 21

APPENDIX A.
Electronics Diagram 22

When applicable, assemblies are grouped by color. All components with that color are included in the assembly.

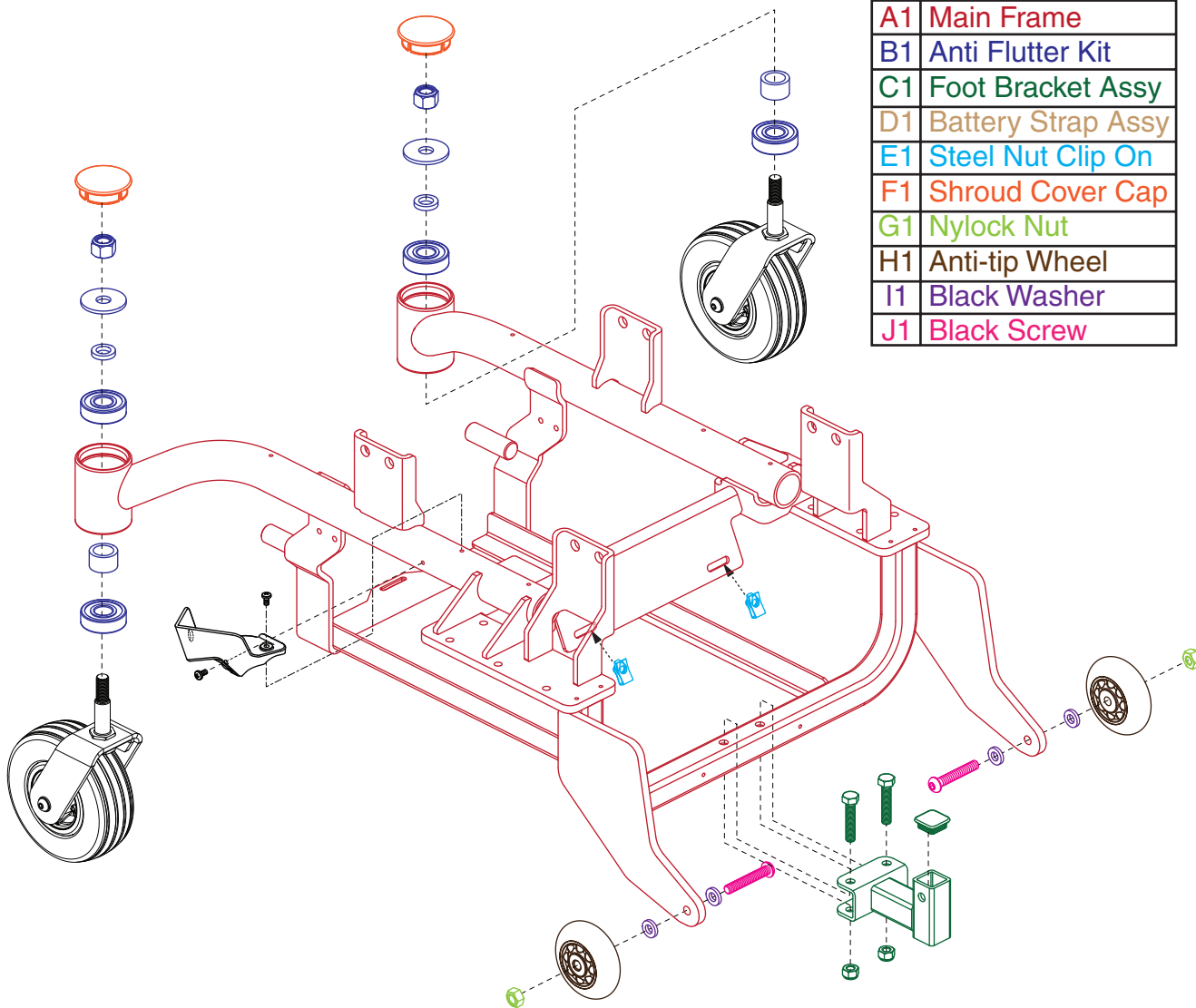

A1	Main Frame
B1	Anti Flutter Kit
C1	Foot Bracket Assy
D1	Battery Strap Assy
E1	Steel Nut Clip On
F1	Shroud Cover Cap
G1	Nylock Nut
H1	Anti-tip Wheel
I1	Black Washer
J1	Black Screw

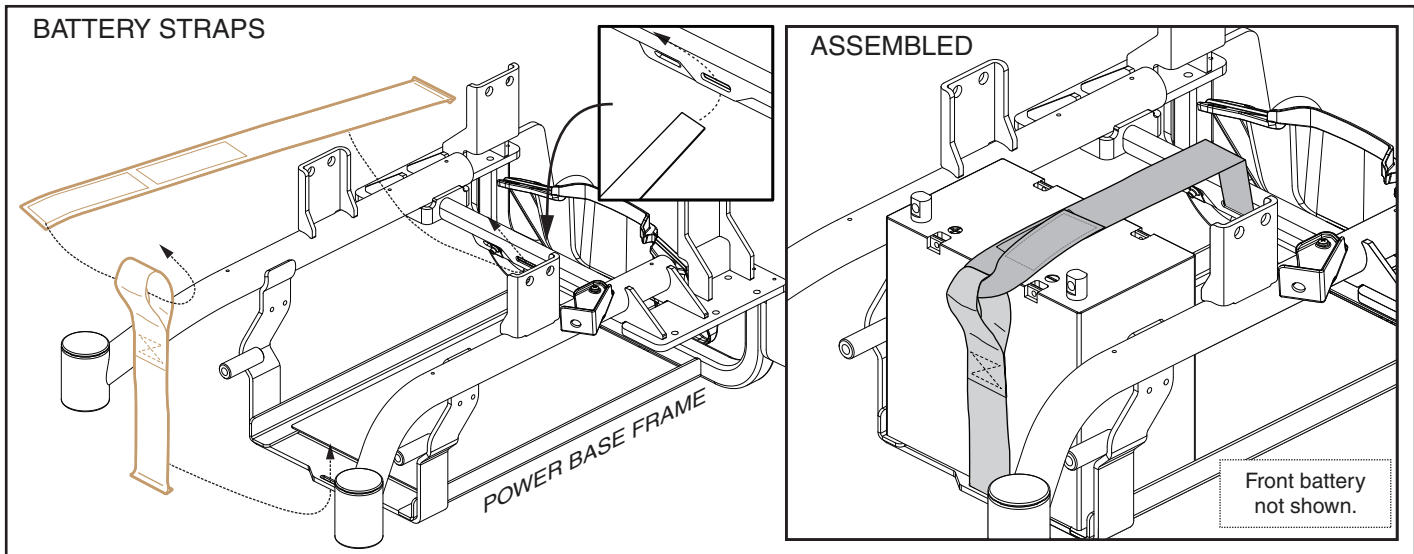

I. Main Frame Assembly

REF #	PART #	DESCRIPTION	QTY	Dealer \$	11i MSRP
A1	FRMASMB7110023	FRAME,ASSY,MAIN,ELITE HD,FRMASMB7110023	1	\$223.32	\$569.47
B1	HDWASMB1187	ANTI-FLUTTER KIT,REAR CASTER,Q6EDGE,C-1062-077	2	\$16.38	\$41.77
C1	FRM7110042	BRACKET,ASSY,FOOT PLATFORM,FRM7110042	1	\$7.41	\$18.89
D1	ACCASMB2627	BATTERY STRAP,ASSY,BLACK,NYLON,W/VELCRO ATTACHMENT,D-1033-036	1	\$1.59	\$4.05
E1	DWR1060C048	NUT,STEEL,U-STYLE CLIP-ON,M5-.8,C-1060-048	2	\$1.16	\$2.96
F1	DWR1065C008	SHROUD,COVER,CAP,CASTER,BLACK,C-1065-008	2	\$1.14	\$2.91
G1	NUTNYLK1011	NUT,NYLOCK,BLACK ZINC,M8-1.25	2	\$1.16	\$2.96
H1	WHLATIP1005	WHEEL, ANTI-TIP, 3" X 1", WITH PLASTIC BUSHING, B-1020-025	2	\$4.81	\$12.25
I1	WASNYLN1085	WASHER,BLACK,NYLON,8.5MM ID X 16MM OD X 3MM TH	4	\$1.14	\$2.91
J1	SCRASBH1247	SCREW,BHSCS,BLACK ZINC,M8-1.25 X 50MM	2	\$1.16	\$2.96

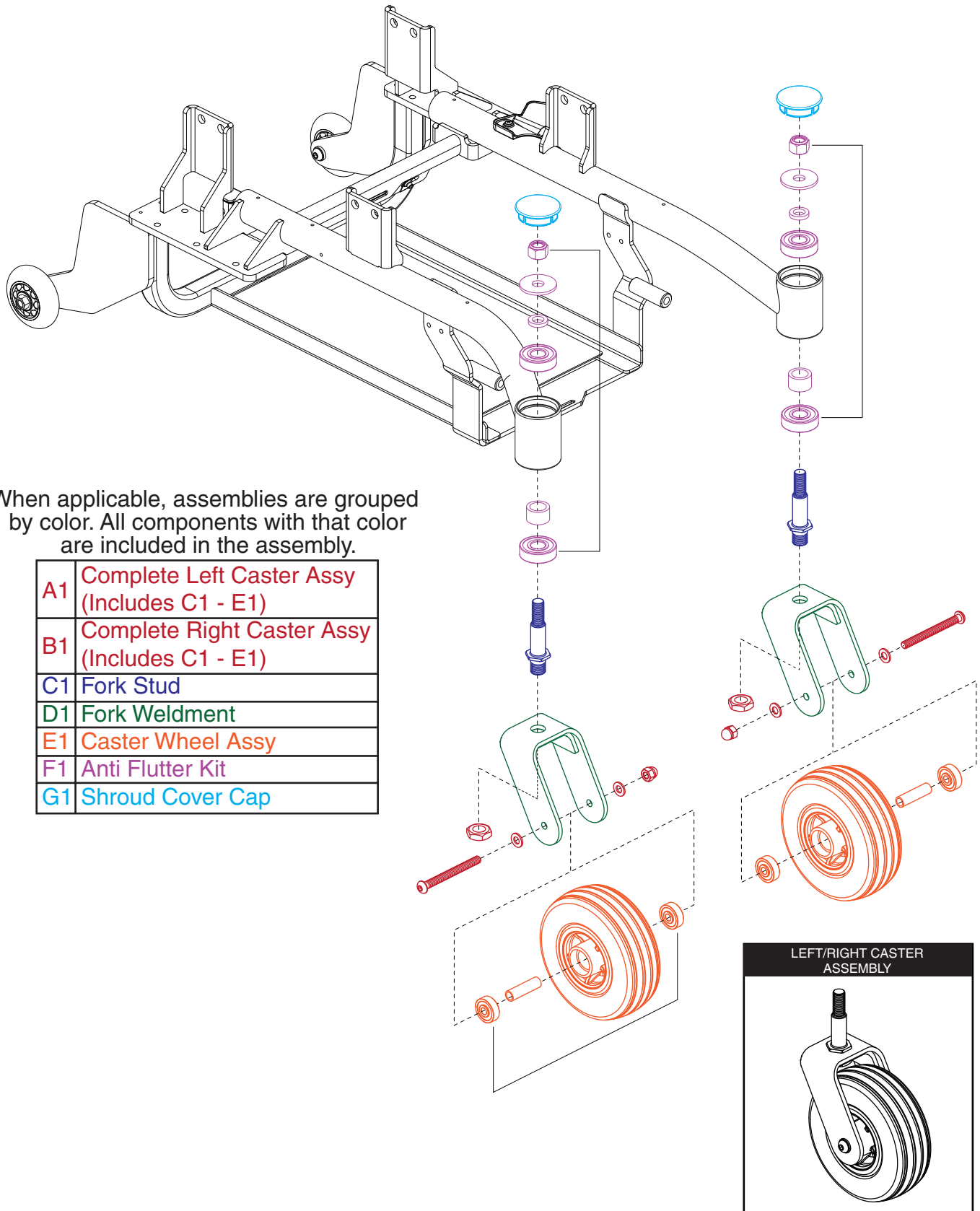

I. Frame Assembly — Rear Caster

REF #	PART #	DESCRIPTION	QTY	Dealer \$	MSRP	11i
A1	CASASMB7110013	CASTER,ASSY,6" FLAT-FREE,HIGH IMPACT WHEEL,SILVER RIM/BLACK TIRE,LEFT,CAS8110004	1	\$51.07	\$130.22	
B1	CASASMB7110018	CASTER,ASSY,6" FLAT-FREE,HIGH IMPACT WHEEL,SILVER RIM/BLACK TIRE,RIGHT,CAS8110005	1	\$51.07	\$130.22	
C1	DWR1005C033	PIVOT STUD,CASTER FORK,BLACK,M16-1.5 (TOP),1/2-20 (BOTTOM) X 88.18MM,REAR,C1005-033	1	\$3.18	\$8.1	
D1	DWR1202D015	FORK WELDMENT,CASTER,BLACK,6" W/RADIUS,REAR,D-1202-015	1	\$8.94	\$22.81	
E1	WHLASMB7110011	WHEEL,ASSY,HIGH IMPACT,SILVER RIM/BLACK TIRE,6" X 2",W/BEARINGS & SPACER,WHL8110001	1	\$32.77	\$83.56	
F1	HDWASMB1187	ANTI-FLUTTER KIT,REAR CASTER,Q6EDGE,C-1062-077	1	\$16.38	\$41.77	
G1	DWR1065C008	SHROUD,COVER,CAP,CASTER,BLACK,C-1065-008	1	\$1.14	\$2.91	



The Power Chair and Quantum Power Base Motors have been consolidated into their own IPB. Please go to the Consolidated Components section to view the IPB or [click here to access the IPB](#)

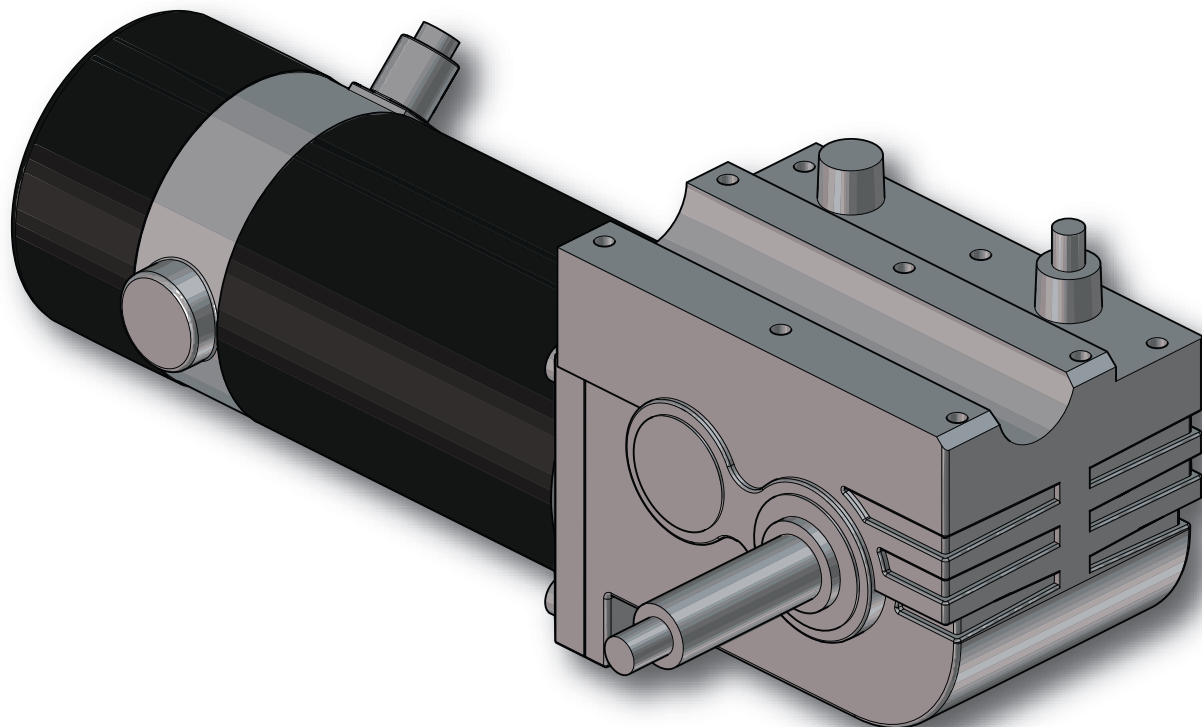



The Power Chair and Quantum Power Base Motors have been consolidated into their own IPB. Please go to the Consolidated Components section to view the IPB or [click here to access the IPB](#)

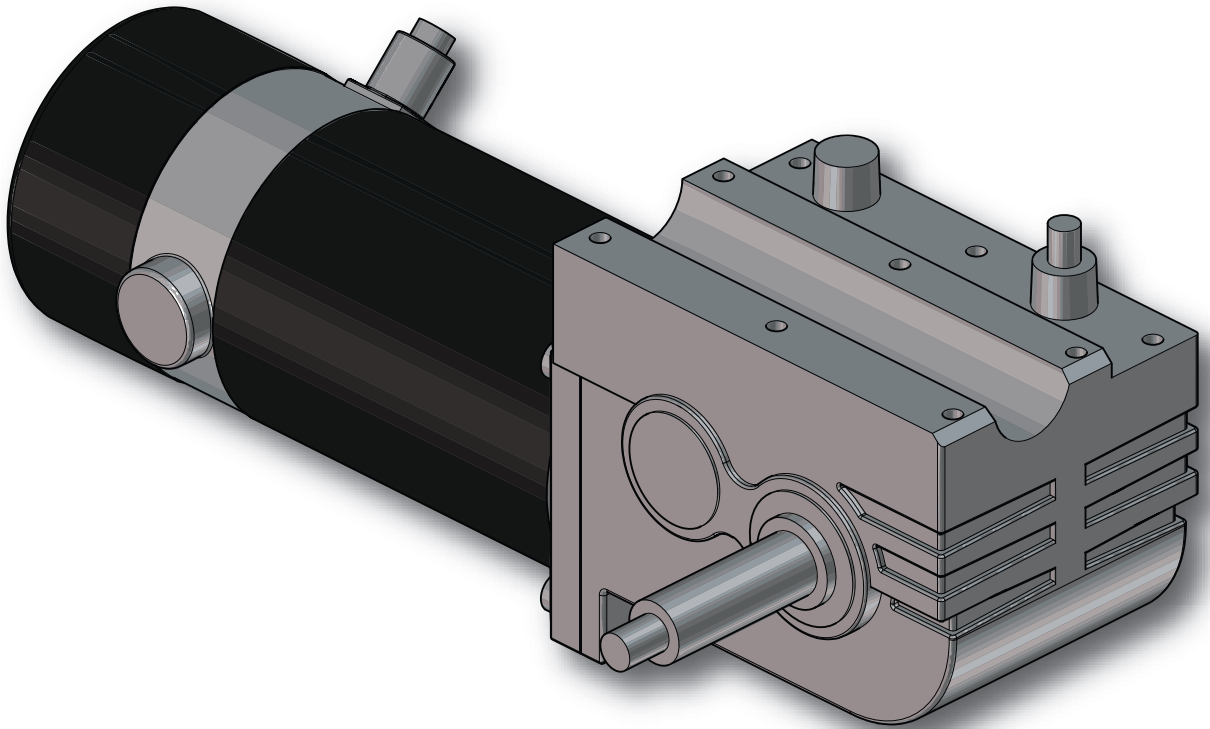

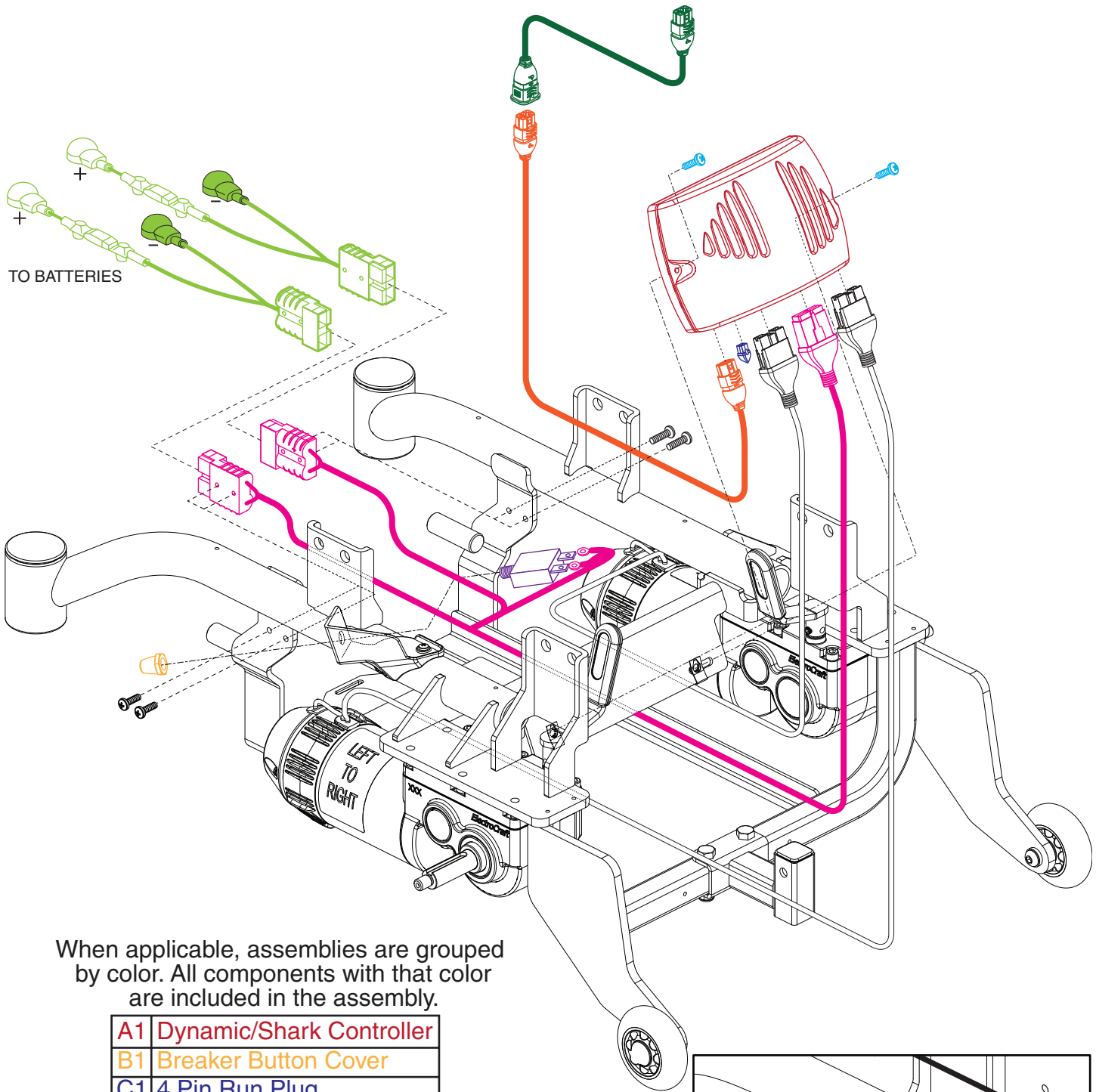

When applicable, assemblies are grouped by color. All components with that color are included in the assembly.

A1	Dynamic/Shark Controller
B1	Breaker Button Cover
C1	4 Pin Run Plug
D1	Dynamic Flight Bus Cable
E1	Shark Bus Cable
F1	Circuit Breaker
G1	Battery cable
H1	Power Cable
I1	Screw

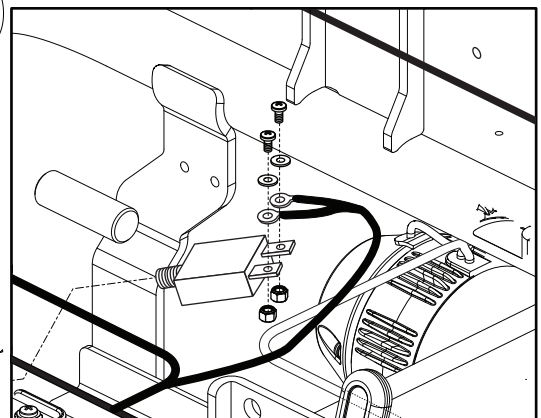

REF #	PART #	DESCRIPTION	QTY	Dealer \$	MSRP	11i
A1	CTL122537	CONTROLLER,DYNAMIC SHARK,ASSY,50 AMP,W/ELITE 14 PROGRAM	1	\$187.87	\$479.06	
B1	INDPART2148	COVER,12 X 1.25T,BREAKER BUTTON, W/NUT	1	\$2.3	\$5.86	
C1	DWR1116H017	ELECTRONIC,HARNESS,4 PIN,RUN PLUG,DYNAMIC FLIGHT,H-1116-017	1	\$2.33	\$5.94	
D1	DWR1056H007	ELECTRONIC,HARNESS,DYNAMIC FLIGHT BUS CABLE,300MM L,H-1056-007,(DYNAMIC: GSM 80203)	1	\$20.25	\$51.63	
E1	DWR1111H204	ELECTRONIC,HARNESS,DYNAMIC SHARK BUS CABLE,1.5M L,H-1111-204,(GSM80233)	1	\$24.99	\$63.72	
F1	ELECBRK1029	ELECTRONIC,CIRCUIT BREAKER,40 AMP,STRAIGHT RING TERMINALS,H-1000-194	1	\$13.76	\$35.1	
G1	HAR8110007	HARNESS,BATTERY,QUICK DISCONNECT,BLACK ANDERSON,NO HANDLE,FUSELINK EXTENSION	2	\$48.69	\$124.15	
H1	HAR8120003	ELECTRONIC,HARNESS,POWER CABLE,SHARK,ELITE HD	1	\$63.51	\$161.94	
I1	SCRPPH1315	SCREW,PPH,BLACK ZINC,M5-.8 X 30MM,(MTS: 51205003)	2	\$1.16	\$2.96	

IV. Foot Platform Assembly

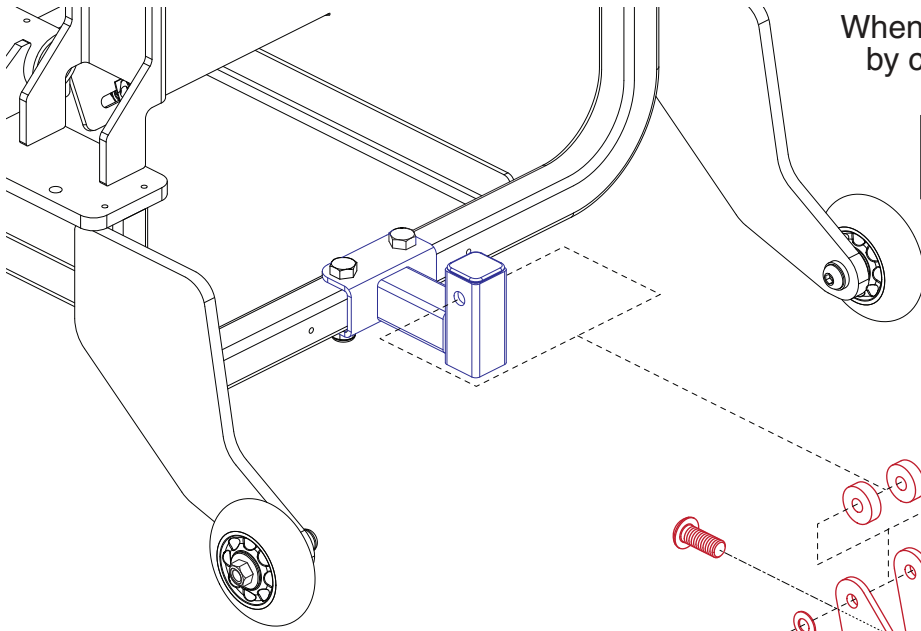

When applicable, assemblies are grouped by color. All components with that color are included in the assembly.

A1	Foot Platform w/ Hardware
B1	Mounting Bracket

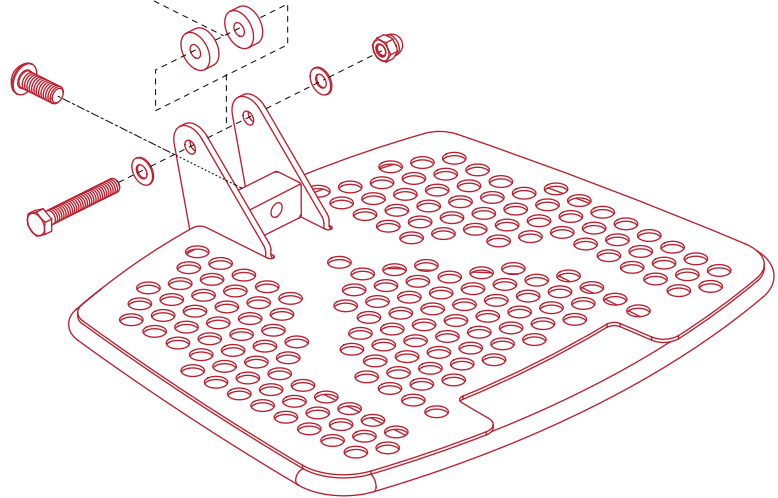

REF #	PART #	DESCRIPTION	QTY	Dealer \$	MSRP	11i
A1	FRMASMB17659	FOOT PLATFORM,ASSY,W/MOUNTING HARDWARE,LARGE,PERFORATED,E-1201-087	1	\$38.46	\$98.08	
B1	FRM7110042	BRACKET,ASSY,FOOT PLATFORM,FRM7110042	1	\$7.41	\$18.89	

The Run Flat Tire is only available with the complete Assembly.

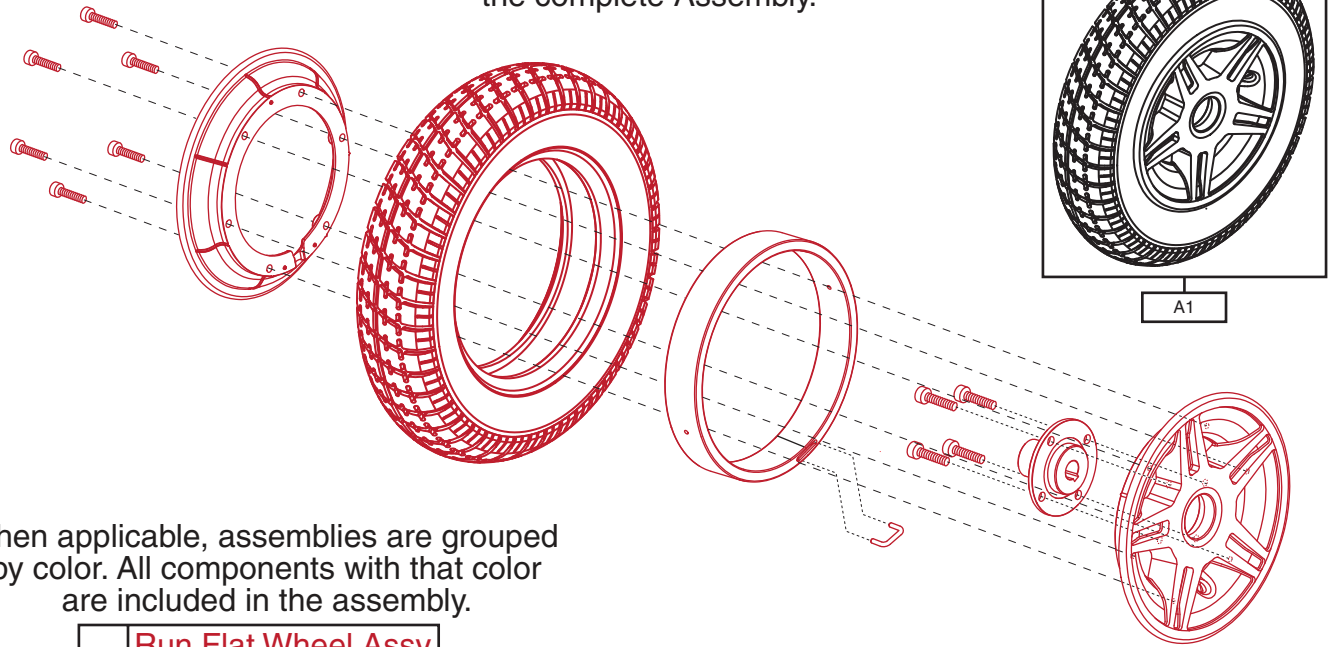

When applicable, assemblies are grouped by color. All components with that color are included in the assembly.

A1	Run Flat Wheel Assy with Star Rim
----	-----------------------------------

REF #	PART #	DESCRIPTION	QTY	Dealer \$	MSRP	11i
A1	WHLASMB2187	WHEEL,ASSY,RUN FLAT,BLACK,14",W/STAR RIM,E-1203-060	1	\$145.71	\$371.55	

When applicable, assemblies are grouped by color. All components with that color are included in the assembly.

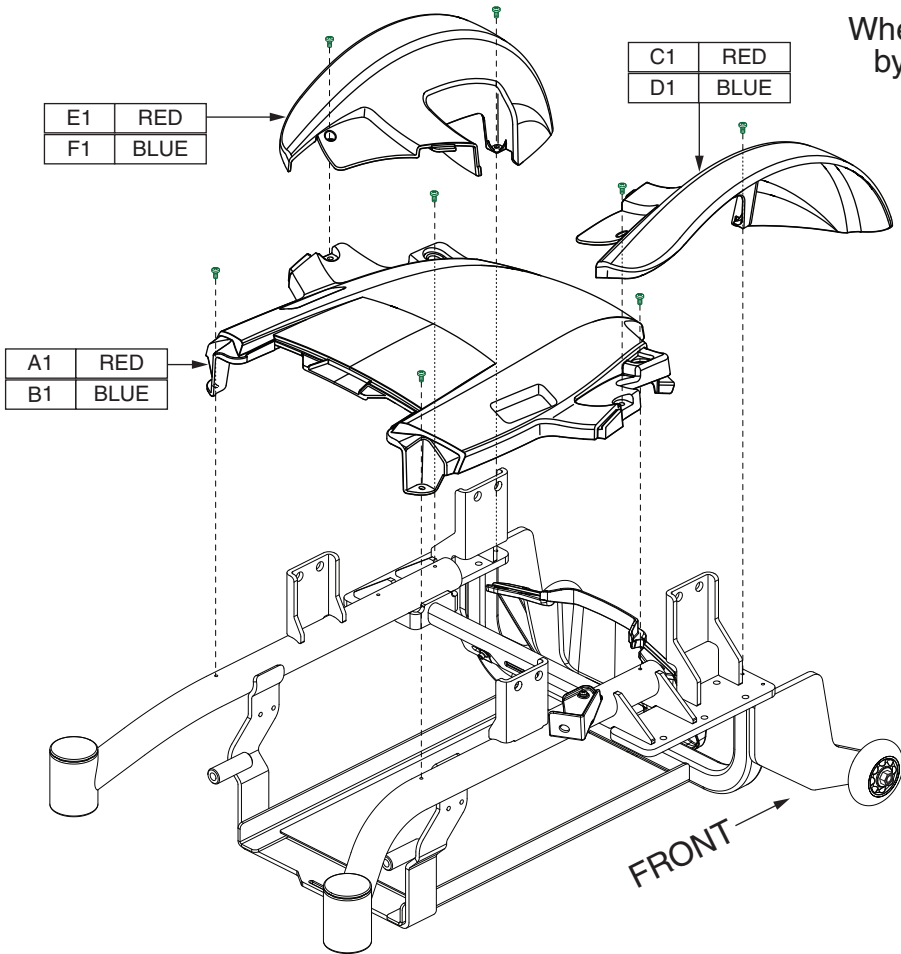

A1	Red Top Shroud with Inserts
B1	Blue Top Shroud with Inserts
C1	Right Red Fender
D1	Right Blue Fender
E1	Left Red Fender
F1	Left Blue Fender
G1	Right Red Reflector
H1	Left Red Reflector
I1	Screw
J1	Front Door
K1	Rear Door Shroud Assy (Includes L1)
L1	Rear Door

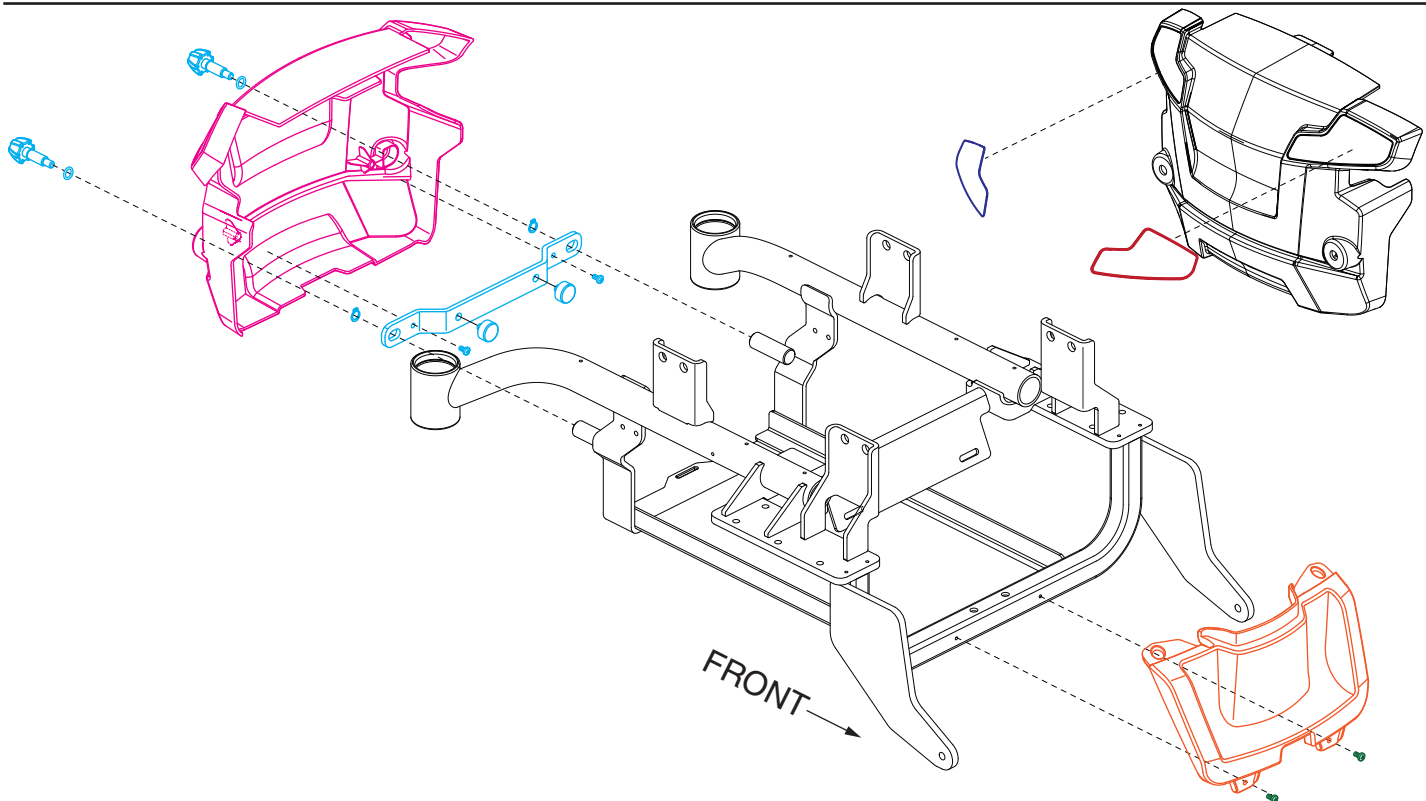

VI. Shroud Assembly

REF #	PART #	DESCRIPTION	QTY	Dealer \$	11i MSRP
A1	SHD8110022	SHROUD, TOP, SOLID RED, W/INSERTS, ELITE HD	1	\$21.17	\$53.98
B1	SHD8110025	SHROUD, TOP, SOLID BLUE, W/INSERTS, ELITE HD	1	\$21.17	\$53.98
C1	SHD8110018	SHROUD, FENDER, RED, RIGHT, ELITE HD	1	\$10.85	\$27.66
D1	SHD8110026	SHROUD, FENDER, BLUE, RIGHT, ELITE HD	1	\$10.85	\$27.66
E1	SHD8110017	SHROUD, FENDER, RED, LEFT, ELITE HD	1	\$10.85	\$27.66
F1	SHD8110023	SHROUD, FENDER, BLUE, LEFT, ELITE HD	1	\$10.85	\$27.66
G1	DEC8110010	REFLECTOR, RED, RIGHT	1	\$2.65	\$6.75
H1	DEC8110009	REFLECTOR, RED, LEFT	1	\$2.65	\$6.75
I1	SCRPPH1036	SCREW, PPH, BLACK ZINC, M4-.7 X 8MM	10	\$1.12	\$2.87
J1	SHD8110016	FRONT DOOR, ELITE HD	1	\$6.62	\$16.87
K1	SHDASMB7110012	SHROUD, ASSY, REAR DOOR, W/THUMB SCREWS, ELITE HD	1	\$26.2	\$66.8
L1	SHD8110020	SHROUD, REAR DOOR, W/INSERTS, ELITE HD	1	\$16.67	\$42.51

VII. Seat Tower Assembly

When applicable, assemblies are grouped by color. All components with that color are included in the assembly.

A1	Seat Tower Trapeze Bar Assy (Includes B1-D1)
B1	Front Trapeze Bar Assy
C1	Rear Trapeze Bar Assy (Includes D1)
D1	Rear Trapeze Bar
E1	Seat Bracket Assy

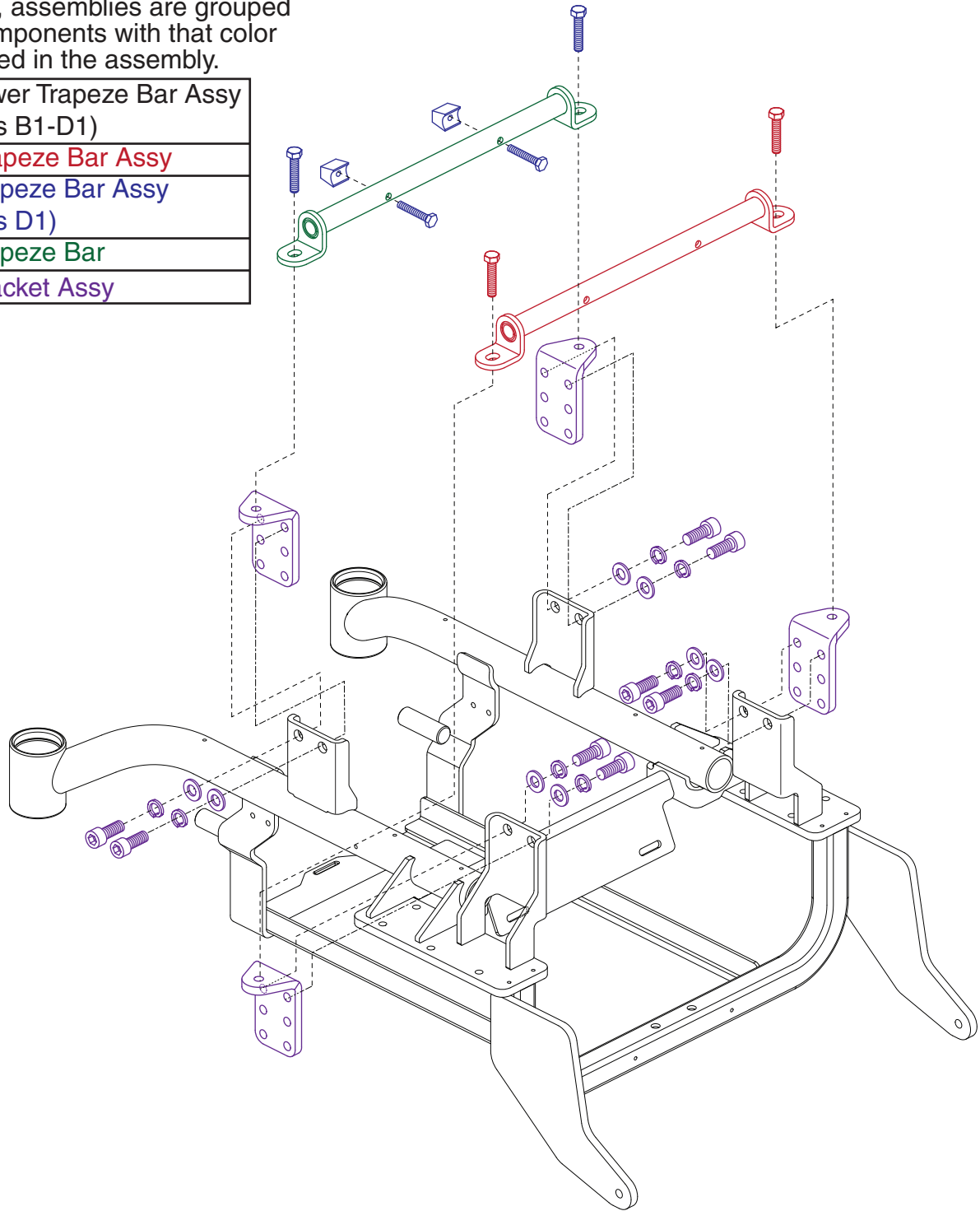

VII. Seat Tower Assembly

REF #	PART #	DESCRIPTION	QTY	Dealer \$	11i MSRP
A1	TWRASMB7120001	SEAT TOWER,ASSY,14.00" CENTERS,TRAPEZE BARS,PAIR,METRIC	1	\$56.39	\$143.79
B1	TWRASMB7120002	SEAT TOWER,ASSY,14.00" CENTERS,FRONT TRAPEZE BAR,METRIC	1	\$8.76	\$22.34
C1	TWRASMB7120003	SEAT TOWER,ASSY,14.00" CENTERS,REAR TRAPEZE BAR,METRIC	1	\$47.63	\$121.46
D1	DWR1062D043	TRAPEZE CROSS BAR,14.00" CENTERS,UNIVERSAL SEAT FRAME,D-1062-043	1	\$6.56	\$16.74
E1	BRKASMB7110030	SEAT INTERFACE,ASSY,L-BRACKET,UNIVERSAL,METRIC,BRKASMB7110030	4	\$19.2	\$48.96

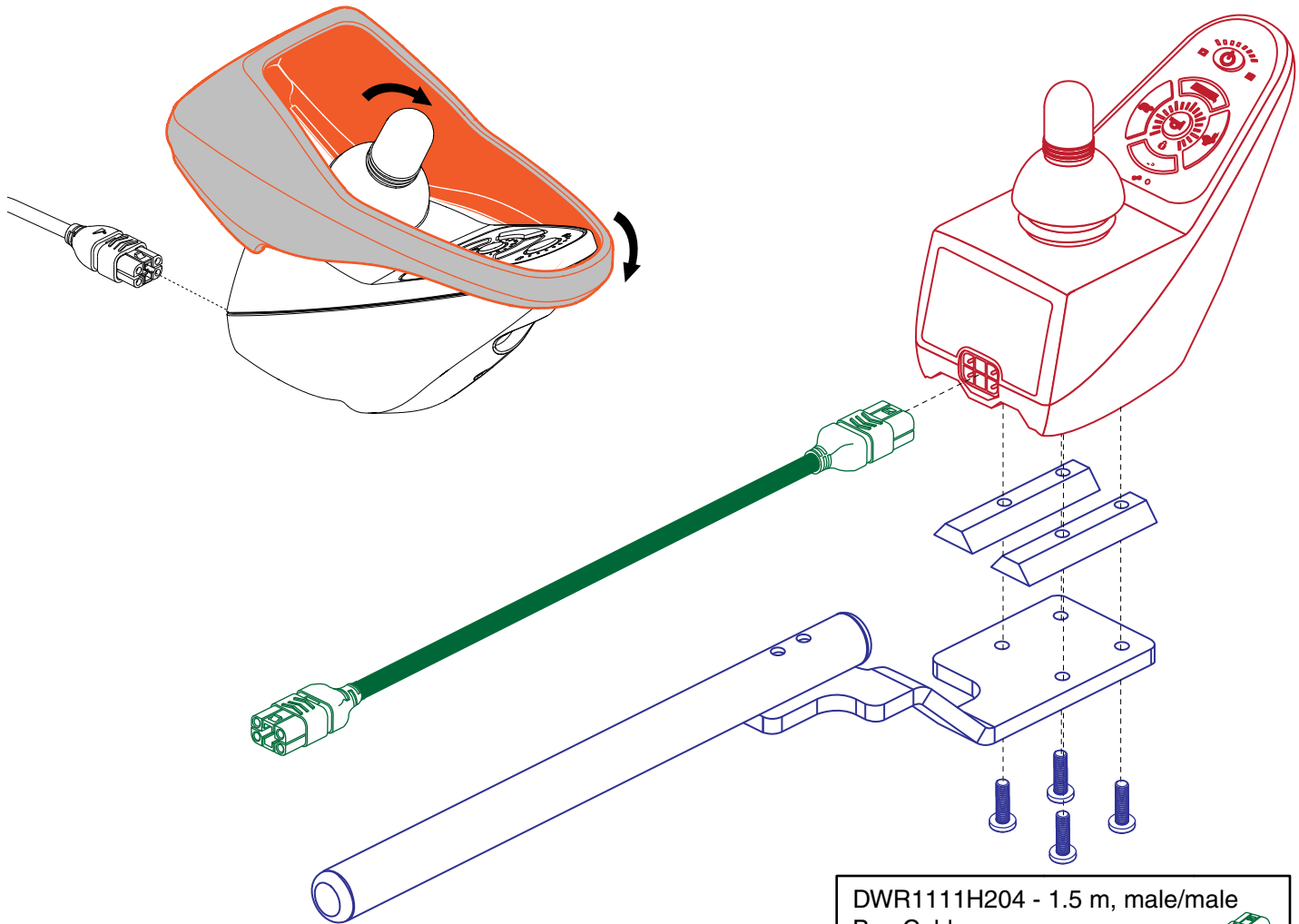

When applicable, assemblies are grouped by color. All components with that color are included in the assembly.

A1	Joystick Controller Assy (Includes B1)
B1	Joystick Cover
C1	Joystick Mounting Bracket Assy
D1	Shark Bus Cable
E1	Flight Bus Cable

DWR1111H204 - 1.5 m, male/male Bus Cable

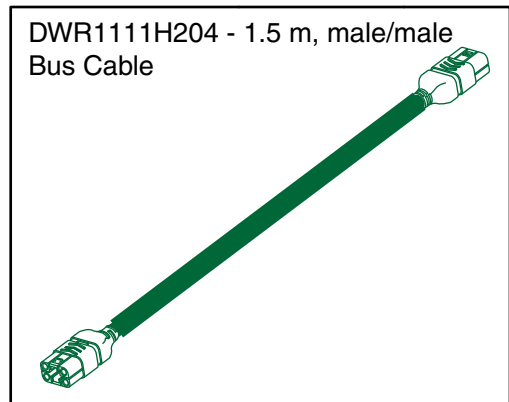

DWR1056H007 - 300mm, male/female Bus Cable

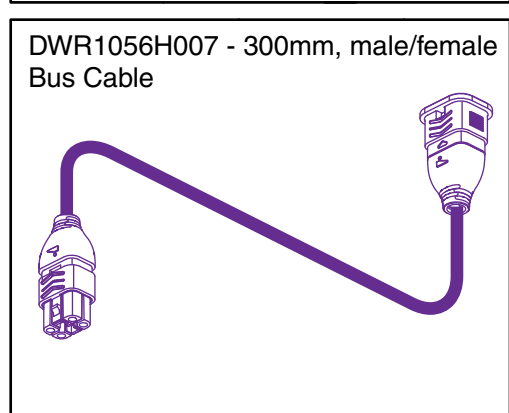

VII. Controller Assembly

REF #	PART #	DESCRIPTION	QTY	Dealer \$	MSRP	11i
A1	ELEASMB7380	CONTROLLER,ASSY,JOYSTICK MODULE,DYNAMIC SHARK,4 KEY,STANDARD,W/COVER	1	\$262	\$668.1	
B1	DWR1010D440	COVER,SHARK CONTROLLER,D-1010-440	1	\$2.12	\$5.4	
C1	FRMASMB11349	JOYSTICK MOUNTING BRACKET,ASSY,SHARK CONTROLLER,INLINE	1	\$11.47	\$29.26	
D1	DWR1111H204	ELECTRONIC,HARNESS,DYNAMIC SHARK BUS CABLE,1.5M L,H- 1111-204,(GSM80233)	1	\$24.99	\$63.72	
E1	DWR1056H007	ELECTRONIC,HARNESS,DYNAMIC FLIGHT BUS CABLE,300MM L,H- 1056-007,(DYNAMIC: GSM 80203)	1	\$20.25	\$51.63	

VIII. Charger Assembly

When applicable, assemblies are grouped by color. All components with that color are included in the assembly.

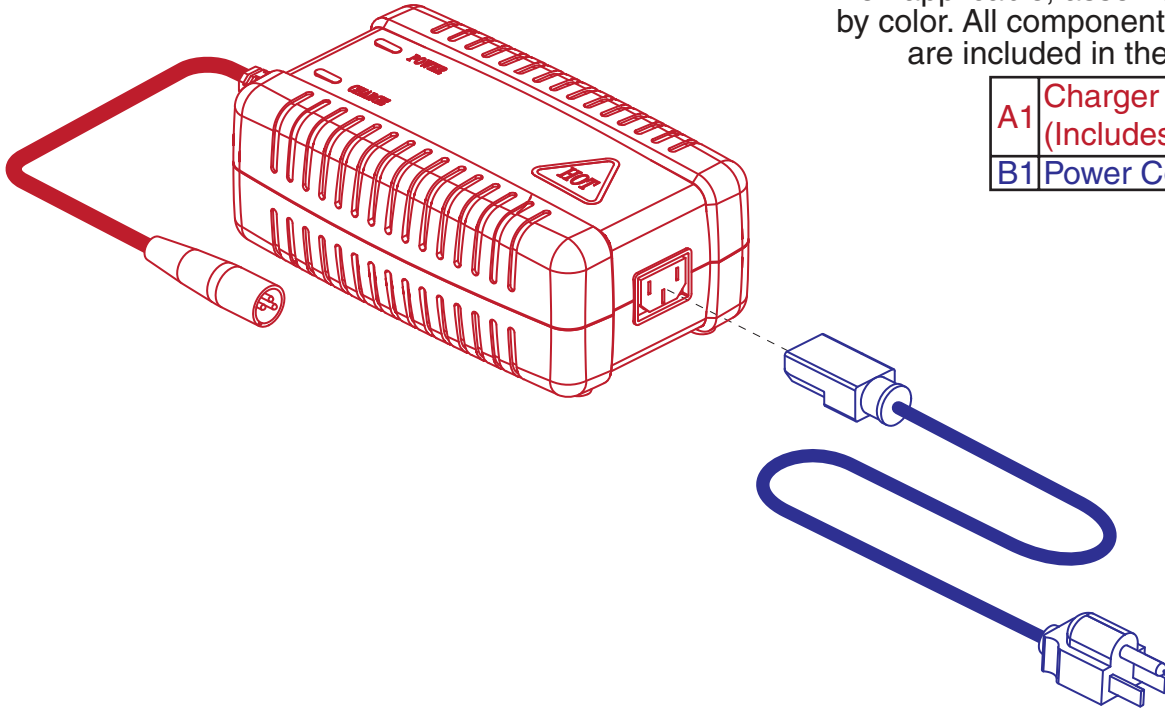

A1	Charger Assy (Includes B1)
B1	Power Cord

REF #	PART #	DESCRIPTION	QTY	Dealer \$	MSRP	11i
A1	ELEASMB6293	CHARGER,ASSY,OFFBOARD,100V-240V,5 AMP,BATTERY MAXIMIZER,W/UNITED STATES POWERCORD	1	\$76.56	\$195.22	
B1	HARUSHD1065	ELECTRONIC,HARNESS,POWER CORD,IEC - USA,H-1000-128	1	\$6.03	\$15.38	

IX. Owner's and Decal Packages

Owner's Package

REF #	PART #	DESCRIPTION	QTY	Dealer \$	MSRP	11i
*N/A	INFMANU4371	MANUAL,OWNER'S,JAZZY ELITE HD/ELITE 14,US	1	\$5.51	\$14.06	
*N/A	INFINFB3086	MANUAL,PRODUCT SPECIFICATION SHEET,JAZZY ELITE 14	1	N/A	N/A	
*N/A	INFINFB1137	MANUAL,WARRANTY CARD,ENGLISH	1	N/A	N/A	
*N/A	PROZBAG1003	BAG,10"L X 12"W X 2MM,ZIPLOCK	1	\$1.1	\$2.81	
*N/A	PLSTIE1013	CABLE TIE,BLACK,NYLON,8" L,40 LBS TENSILE STRENGTH	5	\$1.1	\$2.81	
*N/A	DWR1020L003	HANG TAG,FULLY RECHARGE BATTERY BEFORE INITIAL USE,6-1/4" X 3-3/8",L-1020-003	1	\$1.1	\$2.81	
*N/A	DWR1235L519	HANG TAG,ROUND,GENERIC,COUNTRY OF ORIGIN,L-1235-519	1	\$1.1	\$2.81	
*N/A	HDWINDV1058	HEX KEY,BLACK,4MM	1	\$1.18	\$3.01	
*N/A	VELDBLS1001	REUSABLE FASTENER,1/2"W X 8"L,HOOK & LOOP	1	\$1.16	\$2.96	
*N/A	INFMANU3992	MANUAL,CONSUMER SAFETY GUIDE,POWERCHAIR	1	\$1.12	\$2.86	
*N/A	INFINFB2782	MANUAL,PRODUCT INSERT SHEET,WARRANTY,STANDARD POWER,ENGLISH	1	N/A	N/A	

Decal Package

REF #	PART #	DESCRIPTION	QTY	Dealer \$	MSRP	11i
*N/A	DECSERN1035	DECAL,SERIAL NUMBER,2" X 1.25",BARCODE,MADE IN CHINA,W/PRIDE LOGO	1	\$1.1	\$2.81	
*N/A	LAB120647	DECAL,NAME,ELITE 14	2	N/A	N/A	
*N/A	LAB121220	DECAL,DATA PLATE,JAZZY ELITE 14	1	N/A	N/A	
*N/A	DWR1235L841	DECAL,JAZZY LOGO,L-1235-841	1	\$1.32	\$3.37	
*N/A	DWR1234L811	DECAL,ICON,DO NOT ADJUST ANTI-TIP,1.25" X 0.75",JAZZYSELECT,L-1234-811	2	\$1.1	\$2.81	
*N/A	DEC8120018	DECAL,NOT RATED FOR OCCUPIED TRANSPORT,POWER CHAIR	1	\$3.36	\$8.57	
*N/A	DEC8120015	DECAL,FREEWHEEL,RIGHT,ELITE HD	1	\$1.1	\$2.81	
*N/A	DEC8120016	DECAL,FREEWHEEL,LEFT,ELITE HD	1	\$1.1	\$2.81	
*N/A	DWR1235L520	DECAL,CAUTION,EXTENSION CORD/GROUNDING PRONG,L-1235-520	1	\$1.38	\$3.51	
*N/A	LAB121685	DECAL,CONTROLLER WIRING DIAGRAM,JAZZY ELITE 14	1	N/A	N/A	
*N/A	DEC8120020	DECAL,BATTERY WIRING DIAGRAM,ELITE HD	1	N/A	N/A	
*N/A	DWR1235L515	DECAL,WARNING,BATTERY WARNINGS,L-1235-515	1	\$1.38	\$3.51	
*N/A	LAB121686	DECAL,300 WEIGHT CAPACITY,READ OWNERS MANUAL,INCLINED DECLINED,JAZZY ELITE 14	2	N/A	N/A	
*N/A	DWR1234L799	DECAL,ICON,1" X 2.5",WEATHER/MANUAL/LOOSE GARMENT,L-1234-799	1	\$1.16	\$2.96	
*N/A	DWR1235L521	DECAL,WARNING,CONTROLLER CORD PLACEMENT,L-1235-521	1	\$1.27	\$3.24	

Notes :

*N/A Not applicable.

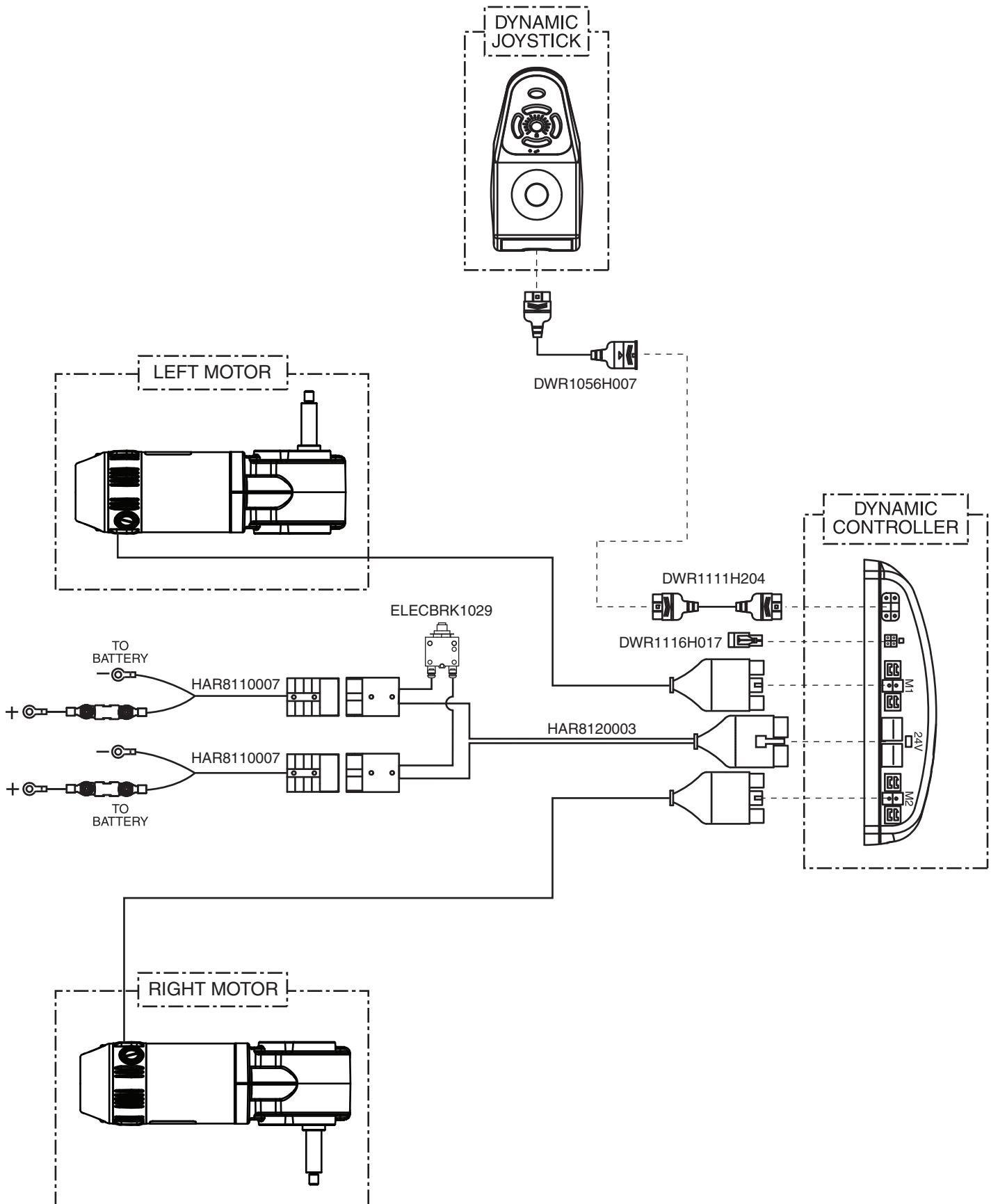

(This page is intentionally left blank.)



Pride[®]

Mobility Products Corp.

www.pridemobility.com

Pride[®] Mobility Products Corporation

182 Susquehanna Avenue
Exeter, PA 18643
USA

Pride[®] Mobility Products Company

5095 South Service Road
Beamsville, ON L0R 1B3
Canada

Pride[®] Mobility Products Ltd.

32 Wedgwood Road
Bicester, Oxon OX26 4UL
UK

Pride[®] Mobility Products Australia Pty. Ltd.

20-24 Apollo Drive
Hallam, Victoria 3803
Australia

Pride[®] Mobility Products Italia S.r.l.

Via del Porgresso - ang. Via del Lavoro
Loc. Prato della Corte
00065 - Fiano Romano (RM)

Pride[®] Mobility Products Europe B.V.

Castricummer Werf 26
1901 RW Castricum
The Netherlands