

Note: All dimensions and tolerances are subject to final product specification

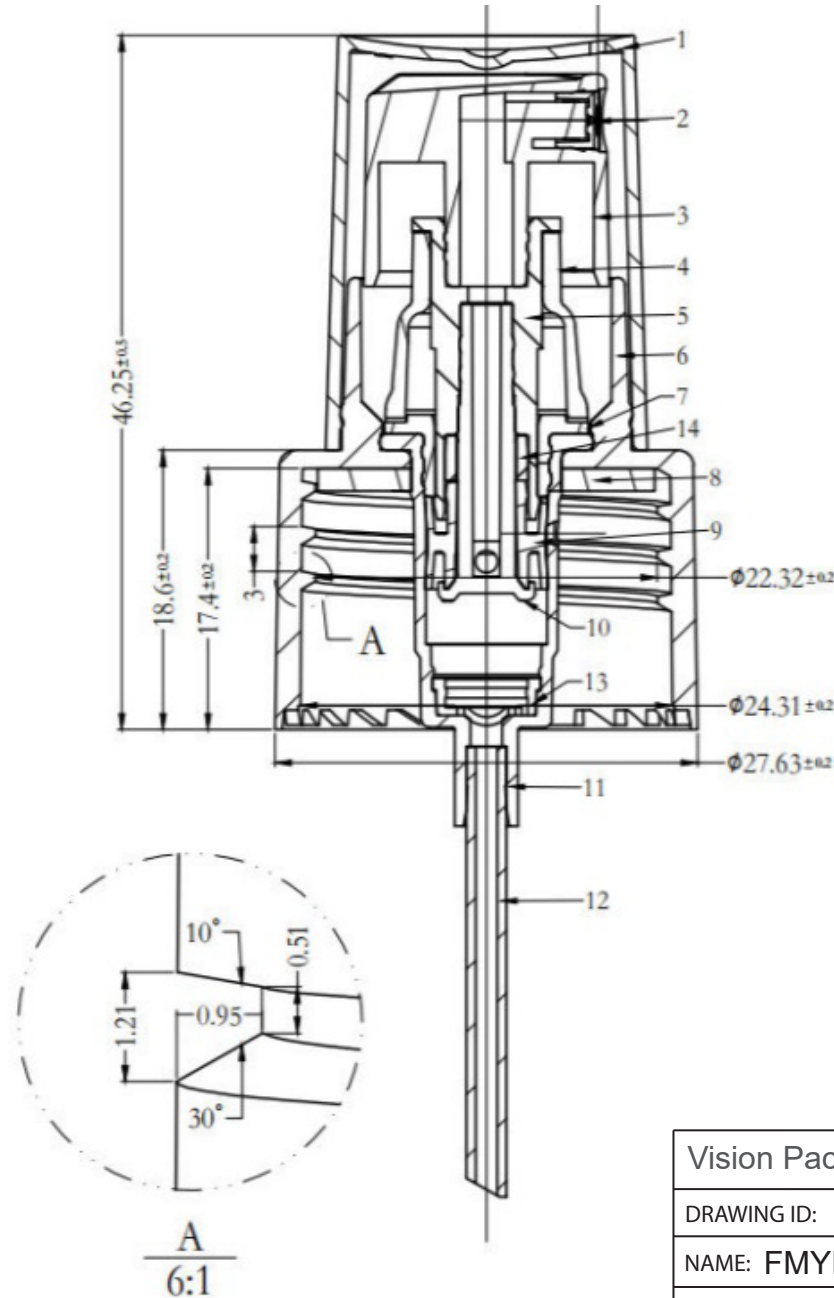

No	Component	Material
1	Overcap	PP
2	Insert	PP
3	Actuator	PP
4	Spring	PE
5	Spring seat	PP
6	Treaded ring	PE
7	Connector	PP
8	Gasket	PE
9	Piston	PE
10	Needle valve	PE
11	Housing	PP
12	Diptube	PE
13	Valve plates	PE
14	Elastic block	PE

Vision Packaging (Aust.) Pty Limited 16 075 725 576	
DRAWING ID: 177sprayfm24AP	DATE: 25/07/2024
NAME: FMYH Fine Mist Spray 24/410 Smooth-Wall + Overcap Square	
NECK: 24/410	DOSAGE: TBA ± 0.020mL
WEIGHT: 7.60g ± 0.5g	UNIT: mm

NOT DRAWN TO SCALE