

SECTION A-A

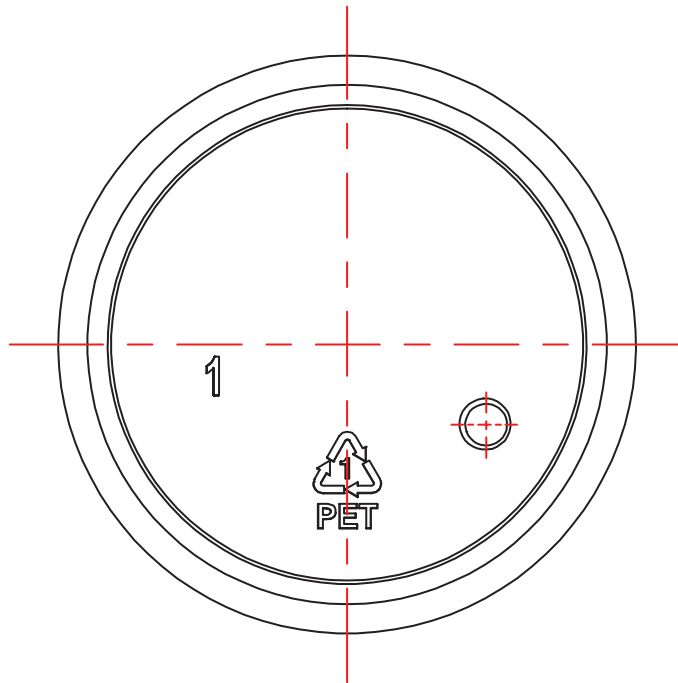

NOT DRAWN TO SCALE

Vision Packaging (Aust.) Pty Limited 16 075 725 576

DRAWING ID: 115jarlowlineheavy0050 DATE: 22/11/19

NAME: Jar Base 50mL Lowline NECK: 56/400

WEIGHT: 15.0gm +/- 2.0gm MATERIAL: PET

BRIMFUL CAPACITY: 77.0mL +/- 5.0mL UNIT: mm