

# Economy Bench

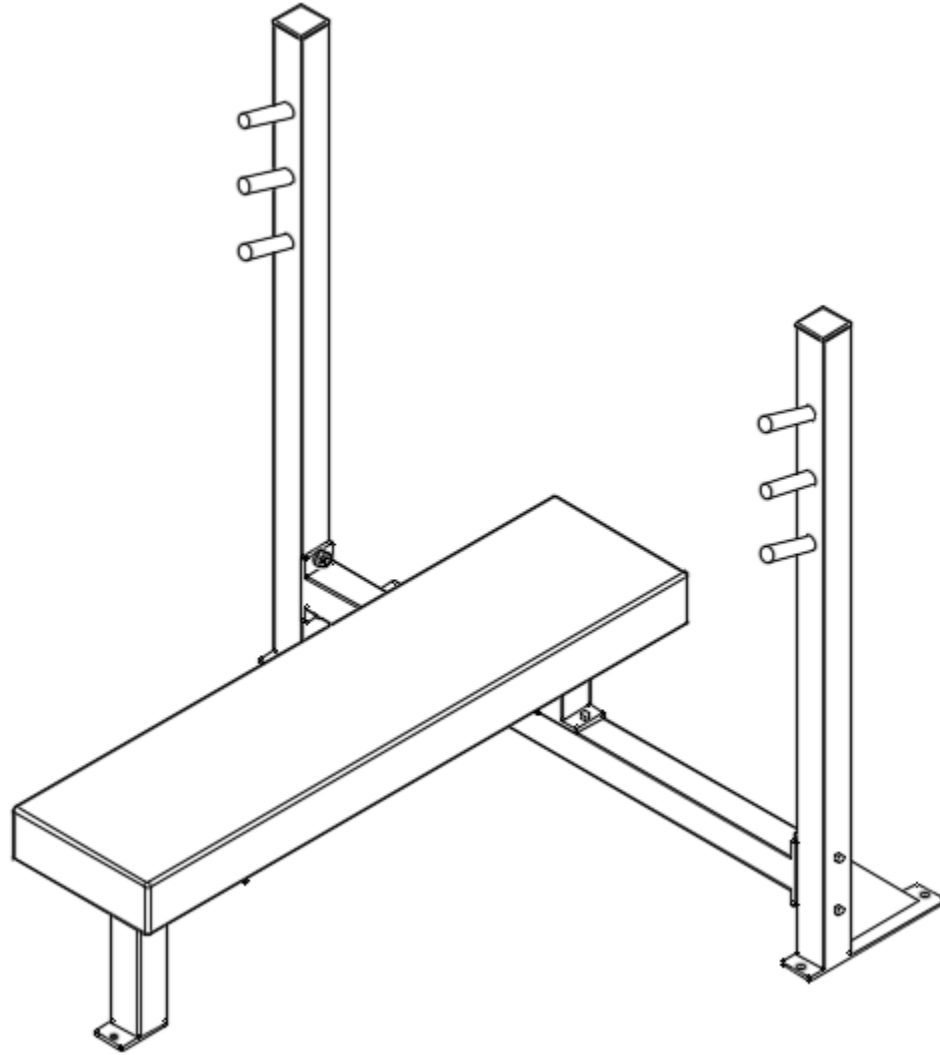

 **WARNING**

Read all safety warnings, instructions and illustrations provided for this piece of strength equipment. Failure to follow all instructions listed below may result in serious injury or death. User assumes all potential risks of assembly or use of this product.

**PERSONAL SAFETY**

- Stay alert, watch what you are doing when assembling and operating the strength equipment. Do not use the strength equipment while you are tired or under the influence of drugs, alcohol or medication. A moment of inattention while operating or assembling the strength equipment may result in serious or fatal injury.

**EQUIPMENT USE AND CARE**

- Visually inspect all components in order to identify potential deformation or damage. If damages are observed, discontinue assembly and contact the manufacturer at [shipping@texasstrengthsystems.com](mailto:shipping@texasstrengthsystems.com), [wesz@texasstrengthsystems.com](mailto:wesz@texasstrengthsystems.com).
- Ensure that all components are securely fastened before use.

## Required Tools

- Crescent Wrench
- 9/16" Socket and Wrench

## Parts

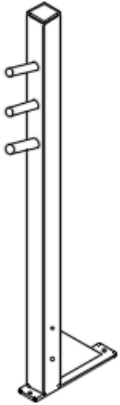

EB-001 | (x2) | Part A

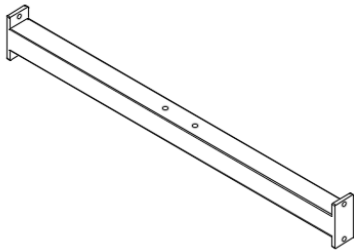

EB-002 | (x1) | Part B

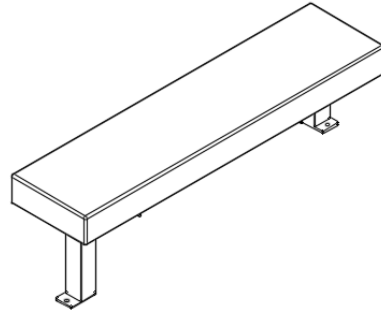

EB-003 | (x1) | Part C

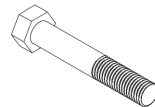

$\frac{3}{8}$ " x 3.75" Bolt | (x6) | Part D



$\frac{3}{8}$ " Flat Washer | (x6) | Part E



$\frac{3}{8}$ " Lock Nut | (x6) | Part F

# Assembly

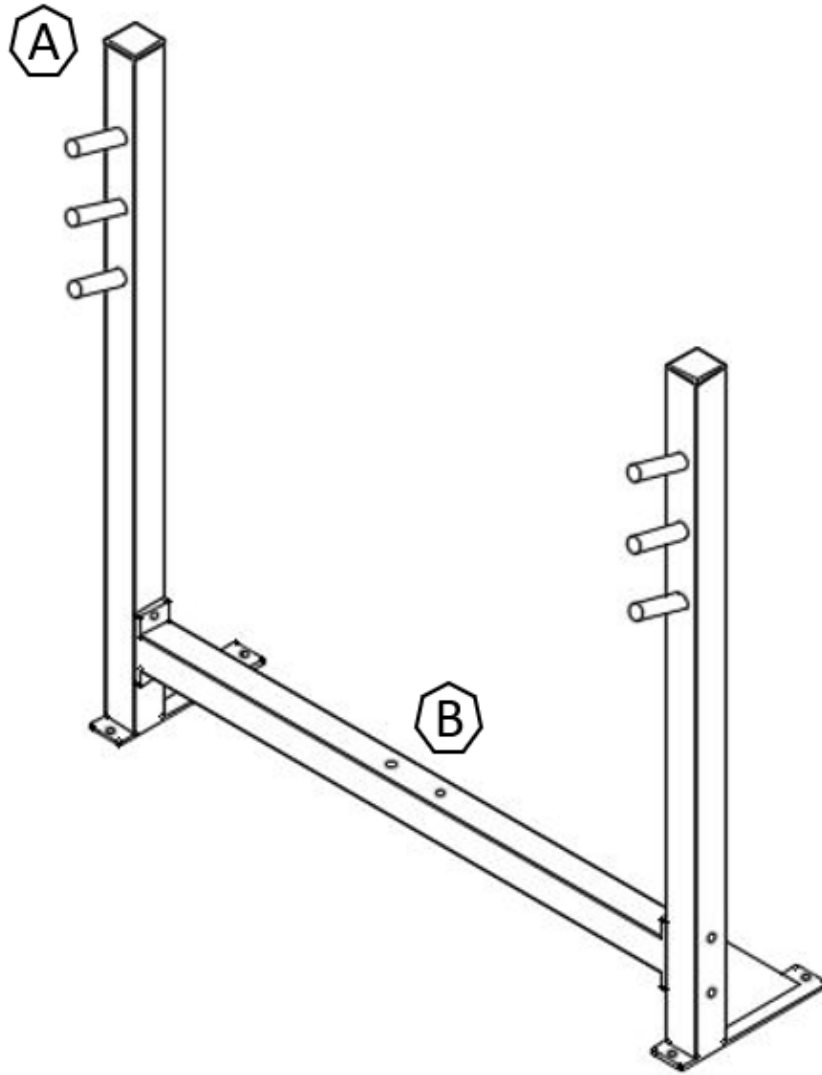

Image 1

Place parts A and B as seen in image 1.

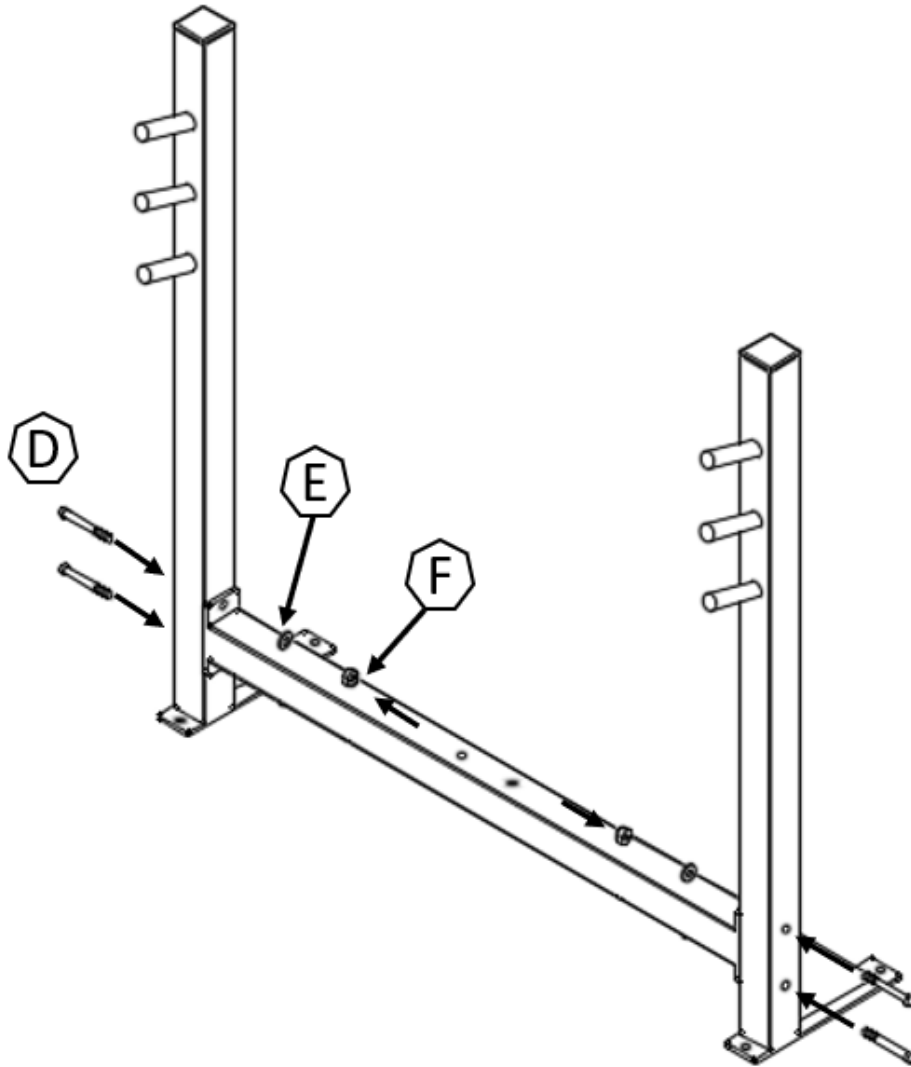

Image 2

Place parts D, E, and F in the organization as seen above and tighten with 9/16 socket and crescent wrench.

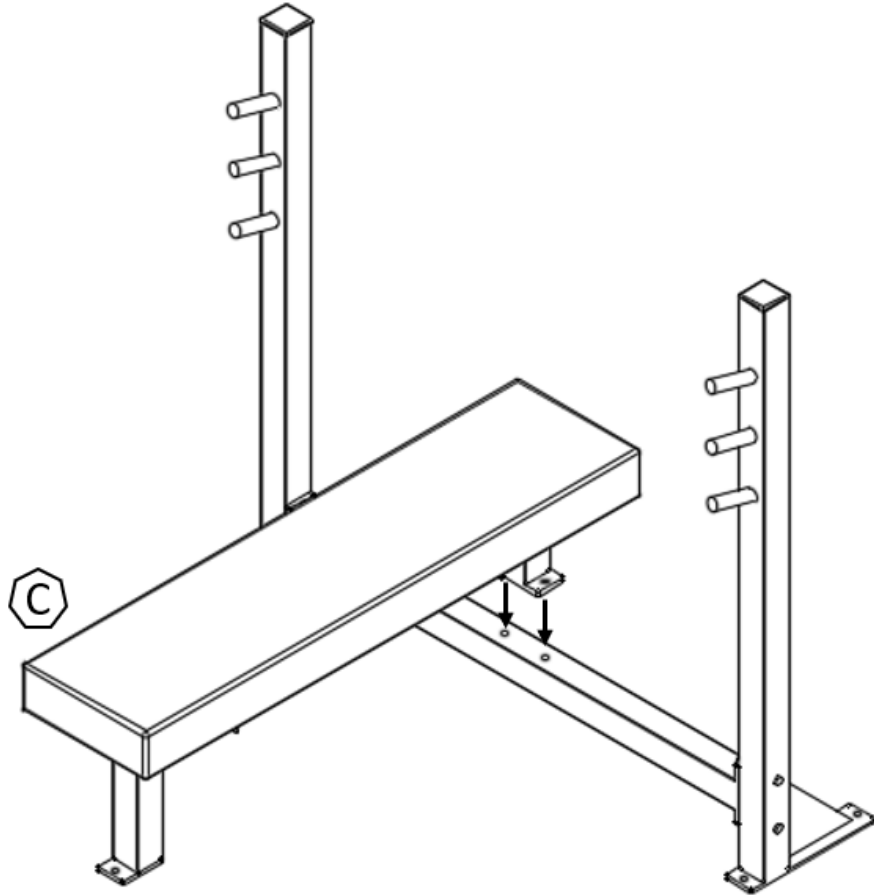

Image 3

Part C will be placed as seen in image 3.

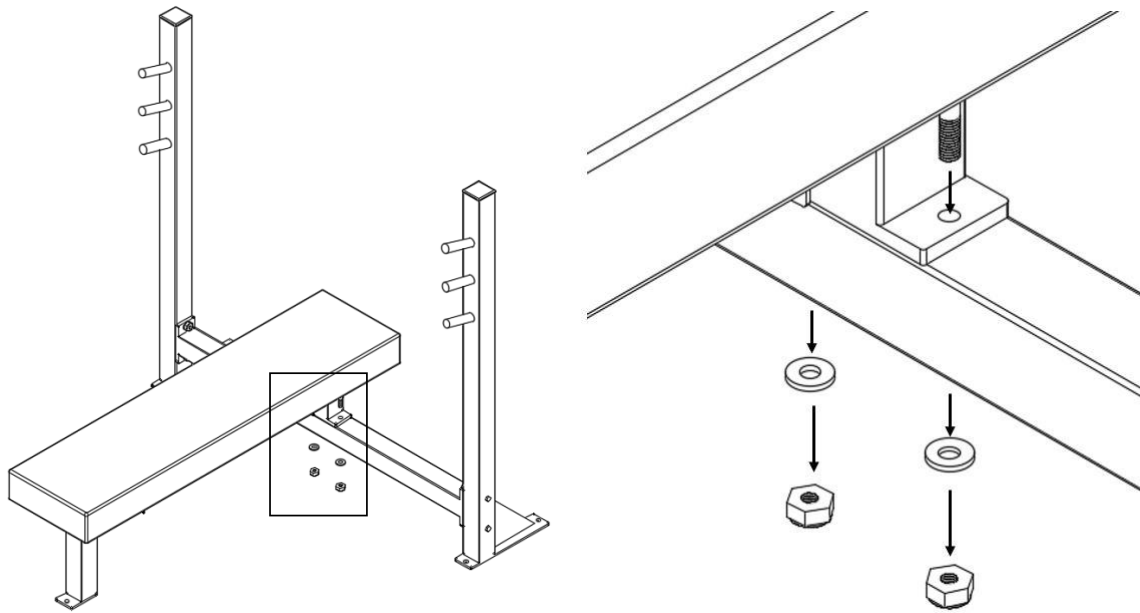
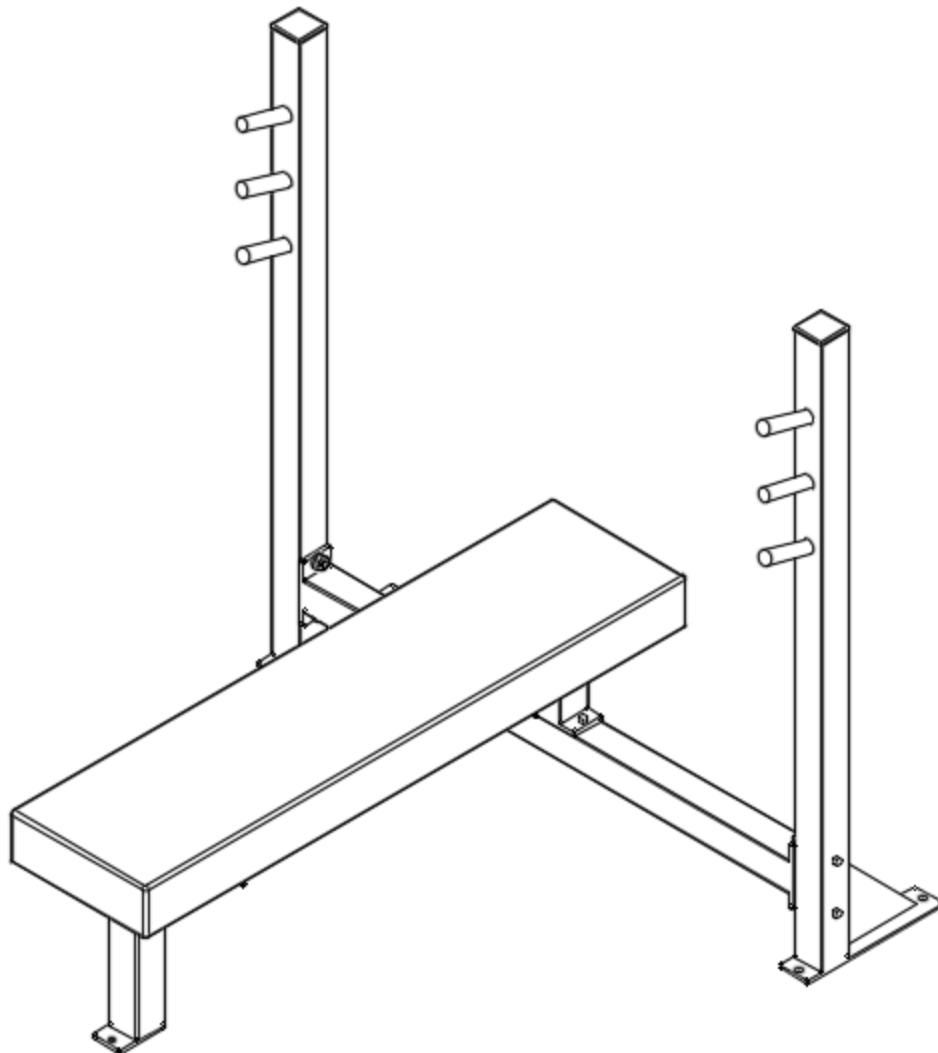

Image 4

Part C will be attached with the remaining hardware as seen in image 4.



You have now completed assembling your very own Economy Bench!  
Thank you for choosing Texas Strength Systems for your fitness needs. If  
you have any questions, comments, or concerns please don't hesitate to  
contact our staff.

**Contact Information**

**Email:** [wesz@texasstrengthsystems.com](mailto:wesz@texasstrengthsystems.com)

**Phone:** (210) 233-6110, (210)-920-4877