

fischer 

UltraCut FBS II.
High-performance
concrete screw
for absolute
installation ease.

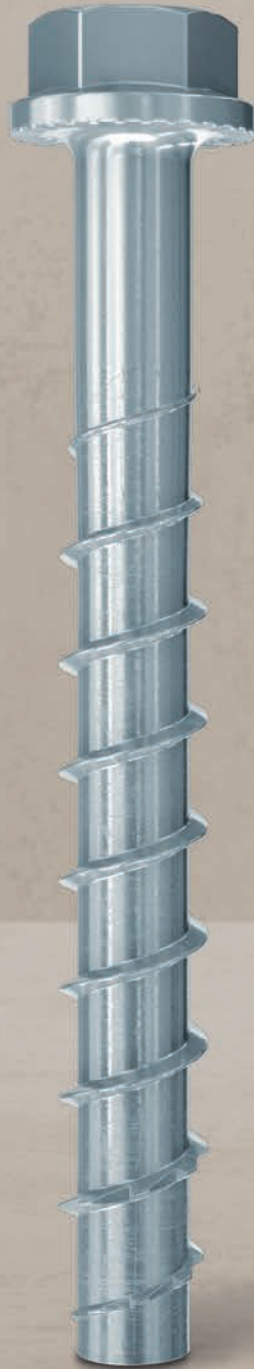

Concrete screw UltraCut FBS II. The assortment for a wide range of applications.



FBS II ZN-plated



FBS II 6 ZN-plated



FBS II CP

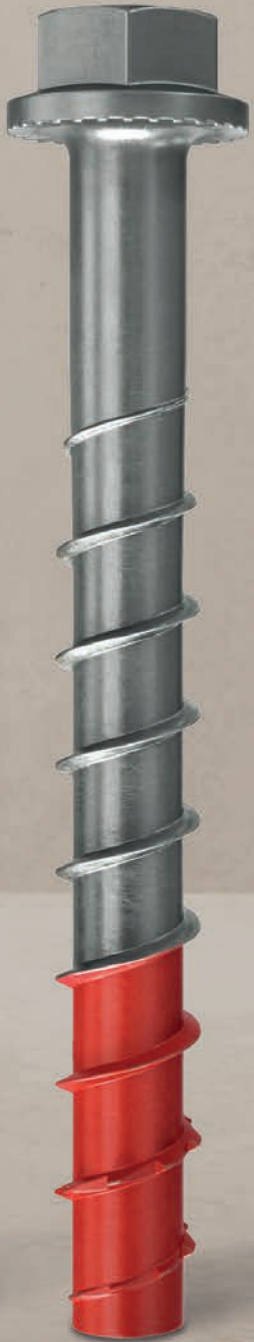

FBS II R



SC-ST



FSW

UltraCut FBS II

8, 10, 12 and 14 zinc-plated steel

The high-performance concrete screw for absolute installation ease in the interior area.

Unique saw-tooth geometry **cuts quickly into the concrete** – also in multiple use and reinforced concrete.

The UltraCut FBS II is available in different head designs. **Countersunk (SK)** and **hexagonal head (US)** with and without internal torx drive.



Through the special thread geometry, the screw flanks cut deeply into the concrete and allow **higher loads**. This **saves costs** because less anchor points and smaller base plates are required.

UltraCut FBS II 10x100 US

The short UltraCut FBS II, with a reduced embedment depth, allows for a **short drill hole depth, fast installation and less reinforcement hits** which makes it an efficient choice for many applications.



UltraCut FBS II 10x60 US

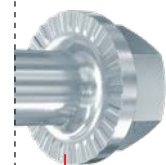

The countersunk head is suitable for **visually appealing installations**.

The ribs under the head prevent accidental loosening of the anchor making the system **more secure**.

Advantages and functions

Your advantages at a glance

- With up to 3 embedment depths, the UltraCut FBS II allows an optimal adaption to different applications / load requirements.
- Expansion-free anchoring (undercut) allows for lowest edge- and axial spacings.
- The assessment (ETA Option 1) covers the use of single-point anchors in cracked and non-cracked concrete.
- The performance categories seismic C1 and C2 ensure that the strictest of safety standards and earthquake specifications can be fulfilled.
- The approved adjustment for the concrete screws allows the screw to be unscrewed twice for a total length of 20 mm, to place maximum 10 mm packing below the base plate head or to align the attached part, and then to tighten the screw again.
- The concrete screws are also approved for multiple use in temporary fixings (e.g. inclined supports) after a verification with the checking gauge FUP. Also with young concrete 10 N/mm².
- Drill holes do not need to be cleaned during vertical installation (ceiling and floor).

Functioning

- The UltraCut FBS II is recommended for the push-through installation.
- The screw is installed correctly when the screw head sits flush on the fixture and cannot be screwed in deeper (visual setting control).
- Drill holes do not need to be cleaned during vertical installation (ceiling and floor). For floor fixings the hole must be drilled 3x drill hole diameter deeper.
- We recommend using a tangential impact wrench with a suitable impact wrench socket (e.g. fischer FSS 18V) or an internal torx drive.
- The assessment document also covers the use of hollow drills with automatic drill hole cleaning and the use of diamond drilling holes.
- The UltraCut FBS II US 8-14 as concrete-concrete connector is also suitable for the strengthening of existing concrete structures through a top concrete layer.

Approvals



ETA-15/0352,
for cracked concrete



ETA-20/0321,
for cracked concrete.
Connector for strengthening
of existing concrete
structures through top
concrete layer



Fire resistance classification
R120



Temporary fixings

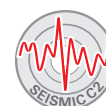

Recommendations

Suitable for building materials, such as



Cracked concrete



Uncracked concrete



Solid brick (masonry)

Installation

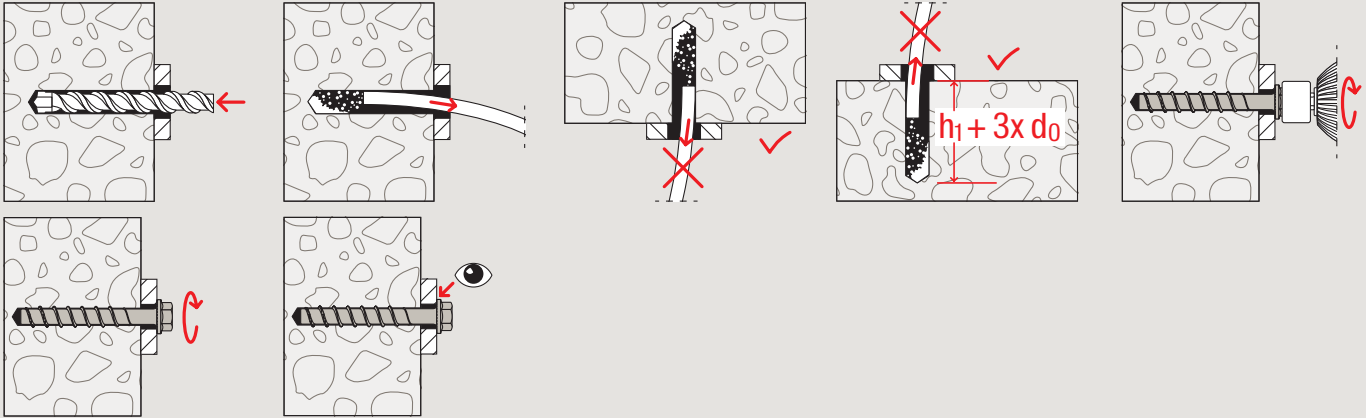

Fixture adjustment

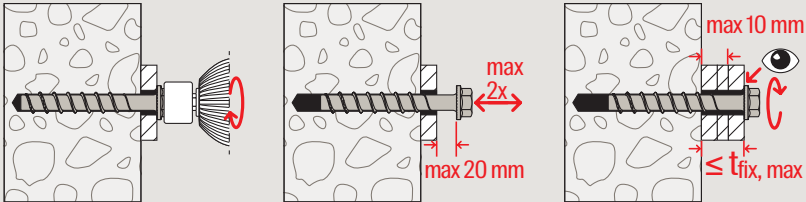

Annular gap filling,

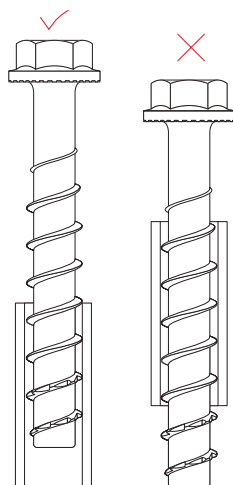
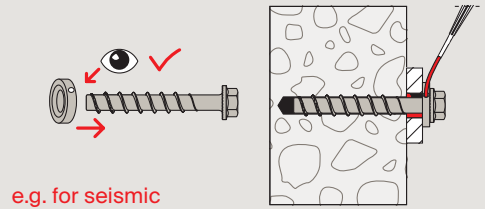

UltraCut FBS II for multiple use of temporary fixings

The FBS II can be used to install temporary construction site installations such as guardrails, inclined supports and frameworks in young concrete of 10 N/mm².

Therefore the FBS II 8, 10, 12 and 14 made of galvanised zinc-plated steel are approved for temporary indoor and outdoor use.

After dismantling, the fischer concrete screw FBS II can be reused.

Depending on the concrete quality, ten or more applications of the same FBS II are possible.

For this purpose the abrasion of the thread is examined with the corresponding checking gauge.

Applications



UltraCut FBS II 8,10,12 and 14

Metal construction



Railings



Shelving systems



Brackets / base plates

Formwork construction / site facilities



Inclined supports



Construction site installations in tunnels

Timber work



Step/rise anchorage



Beam anchorage

Sanitary, heating and electrical industry



Suspended mounting channels

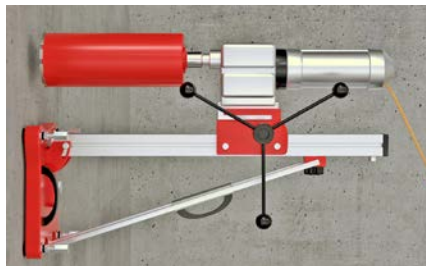

Diamond drilling equipment



Cable trays

UltraCut FBS II

6 zinc-plated steel

Different head designs offer a maximum of flexibility and a perfect adaptation to the application.



UltraCut FBS II 6 SK

The special double angle on the under-head geometry **increases the stability of the concrete screw** during screwing in.



UltraCut FBS II 6 P / LP

The design of the concrete screw with panhead and large panhead allows **aesthetic installation**.



UltraCut FBS II 6 US

The special head geometry for use in mounting rails (up to 17 mm slot width) with a socket (SW10) enables **simple installation of the add-on part**.



UltraCut FBS II 6 M8 or M10

The hanger bolt enables the **easy and suitable application of pipe clamps** and connecting elements.



UltraCut FBS II 6 M6 I, M8/M10 I

The design of the concrete screw with connection sleeve with step thread offers **maximum flexibility when mounting threaded rods or connecting elements**.



Advantages and functions

Your advantages at a glance

- The special ratio between flank and shaft diameter allows for a deep and fast cutting into the concrete.
- The ETA assessment option 1 includes the use in cracked and non-cracked concrete for highest safety requirements.
- The UltraCut FBS II 6 is approved for multiple use of non-load bearing systems and thereby ideal for the installation of pipe routes and prestressed hollow concrete ceilings.
- The first diameter 6 mm concrete screw with an ETA assessment for the C1 seismic performance category for additional safety standards.
- The approved adjustment for the concrete screws allows the screw to be unscrewed twice for a total length of 20 mm, to place maximum 10 mm packing below the screw head or to align the attached part, and then to tighten the screw again.
- Drill holes do not need to be cleaned during vertical installation (ceiling and floor).

Functioning

- The UltraCut FBS II 6 ZN-plated is recommended for the push-through and pre-positioned installation.
- The screw is installed correctly when the screw head sits flush on the fixture/substrate surface and cannot be screwed in deeper (visual setting control).
- We recommend using a tangential impact wrench with a suitable impact wrench socket (e.g. fischer FSS 18V) or an internal torx drive.

Approvals



ETA-15/0352,
for cracked concrete



ETA-18/0242,
for non-structural
applications in
concrete



Fire resistance classification
R120



According VdS
CES-Guidelines for
sprinkler systems



Recommendations

Suitable for building materials, such as



Cracked concrete



Uncracked concrete



Solid brick (masonry)



Variable embedment depths (Multiple use of redundant systems)

Enables a flexible adaptation to the loads.

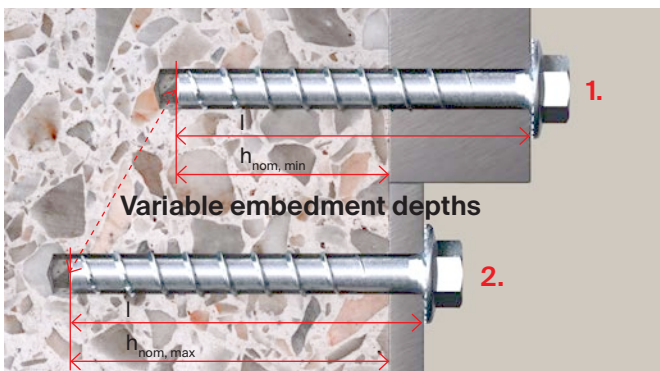

**1. Fast installation due to minimum embedment depth
e.g. FBS II 6x60/5 US**

- Minimum embedment depth is 25 mm
- Permissible tensile load at $h_{nom, min} = 25$ mm is 0.7 kN
- Permissible shear load at $h_{nom, min} = 25$ mm is 1.8 kN

**2. Maximum load due to maximum embedment depth
e.g. FBS II 6x60/5 US**

- Minimum embedment depth is 55 mm
- Permissible tensile load at $h_{nom, max} = 55$ mm is 4.0 kN
- Permissible shear load at $h_{nom, max} = 55$ mm is 6.3 kN

Installation and applications

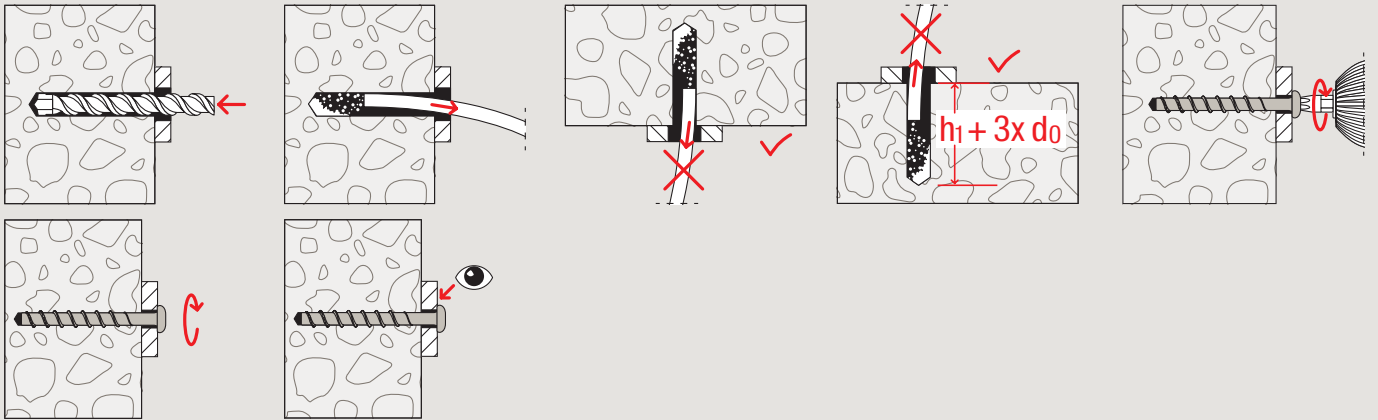

Fixture adjustment

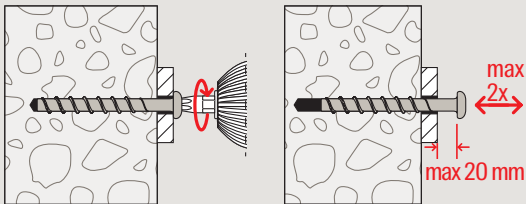

Annular gap filling,

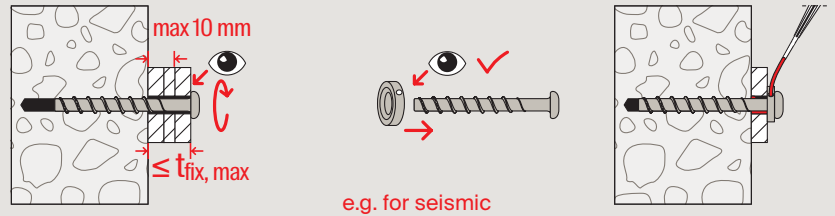

UltraCut FBS II 6

Sanitary, heating and electrical industry



Mounting channels

e. g. UltraCut FBS II 6 US



Suspended mounting channels

e. g. UltraCut FBS II M8/19



Perforated tapes

e. g. UltraCut FBS II LP



Prestressed hollow concrete ceilings

e. g. UltraCut FBS II M8/M10 I



UltraCut FBS II

8, 10, 12 and 14 CP

The high-performance concrete screw for absolute installation ease with a special coating.

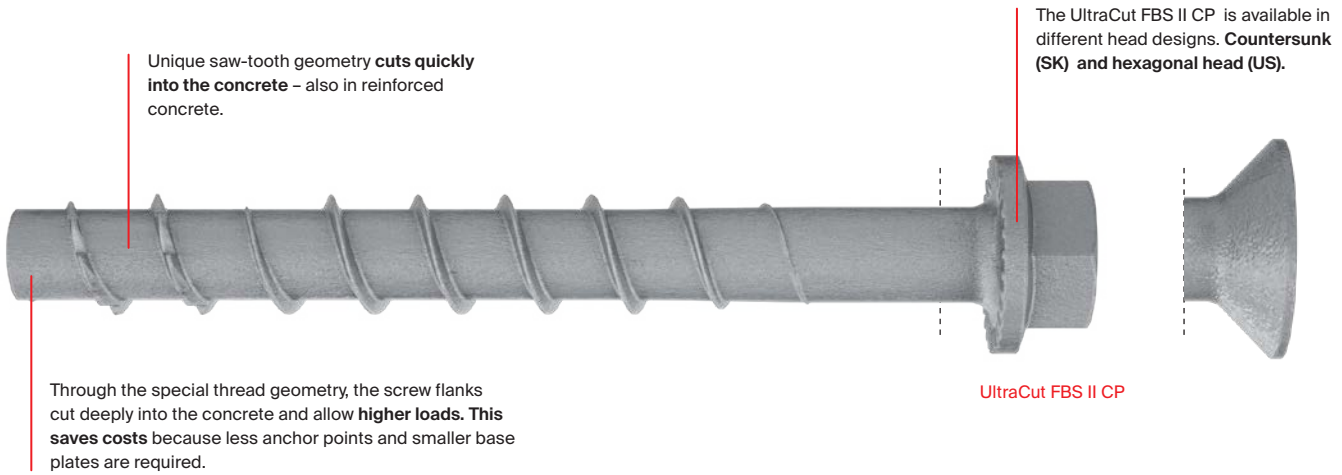

Through the special thread geometry, the screw flanks cut deeply into the concrete and allow **higher loads**. This **saves costs** because less anchor points and smaller base plates are required.

Tested and approved: High protection of the coating against red rust.

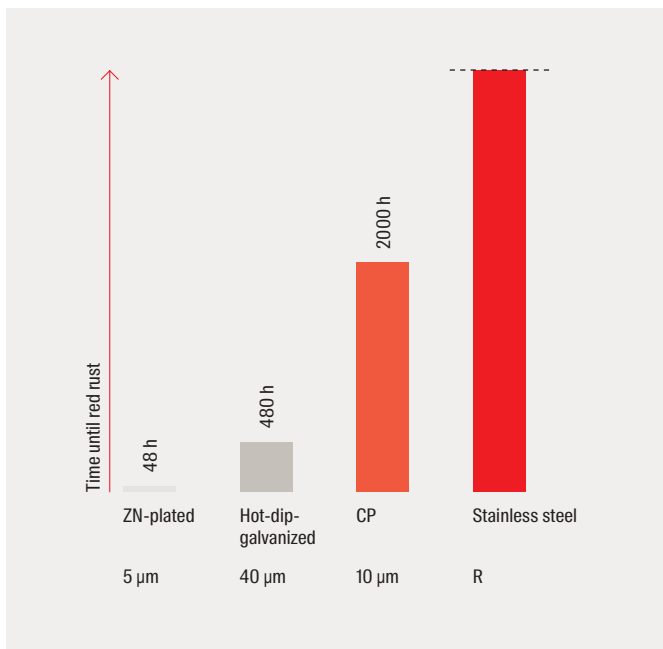

Salt spray chamber mist test

The UltraCut FBS II was developed in different coatings subjected to the salt spray chamber mist test according to DIN EN ISO 9227. The result is that the UltraCut FBS II CP coating withstands at least 2,000 h without red rust.

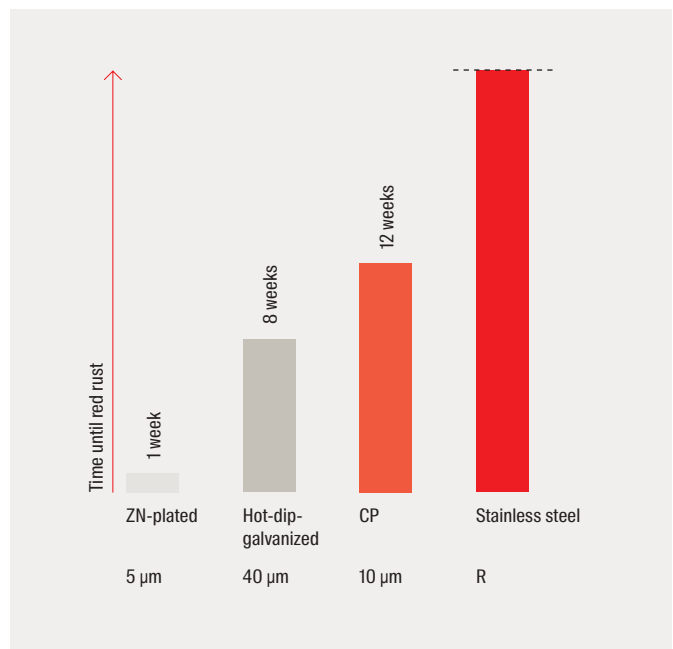

Climate change test (among other things based on Nord-test Method NT)

The climate change test simulates a realistic environment with changing humidity and heat. Here too, the coating of the UltraCut FBS II CP performs significantly better than the usual coatings galvanised zinc-plated (ZN-plated) and hot deep galvanised (HDG).

Advantages and functions

Your advantages at a glance

- The innovative surface coating enables an additional corrosion protection (e.g. through external test reports for the salt spray chamber mist test over 2000 h).
- With up to 3 embedment depths, the UltraCut FBS II allows for the same screw to be used for different component thicknesses.
- The ETA approval covers the application in cracked concrete and the seismic performance categories C1 and C2.

Functioning

- The UltraCut FBS II CP is recommended for the push-through installation.
- The screw is installed correctly when the screw head sits flush on the fixture and cannot be screwed in deeper (visual setting control).
- We recommend using a tangential impact wrench with a suitable impact wrench socket (e.g. fischer FSS 18V) or an internal torx drive.
- The assessment document also covers the use of diamond drilled holes.

Approvals



ETA-15/0352,
for cracked concrete



Fire resistance classification
R120



Recommendations

Suitable for building materials, such as



Cracked concrete



Uncracked concrete



Solid brick (masonry)

Installation and applications

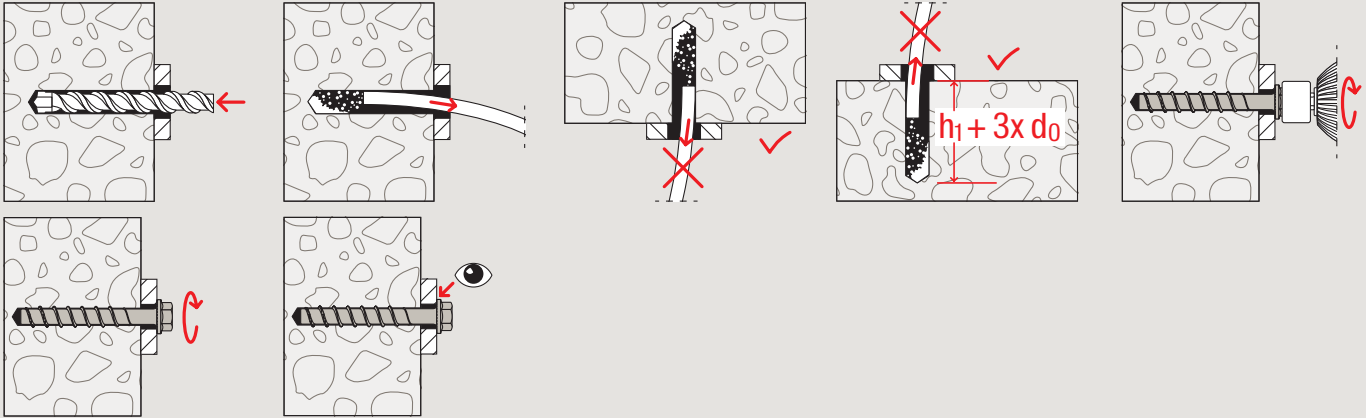

Fixture adjustment

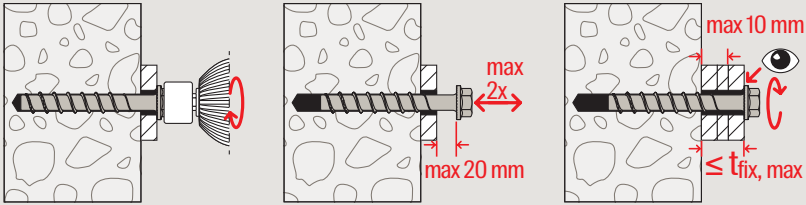

Annular gap filling,

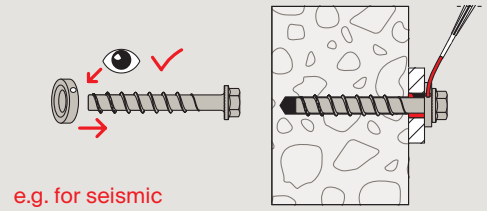

UltraCut FBS II CP

Steel construction



Façade substructures



Connection angle

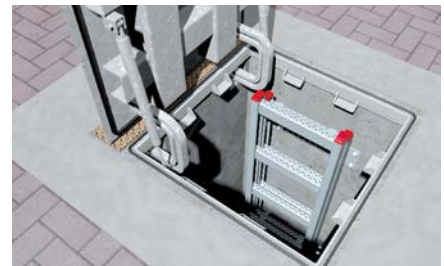

Ladder shafts

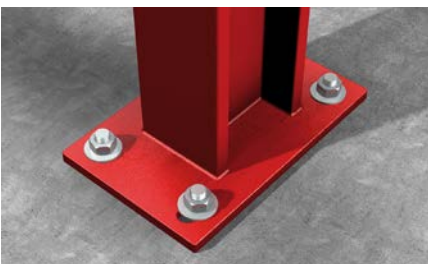

Steel girders

fischer Professional.

The app for fixing professionals.

www.fischer.de

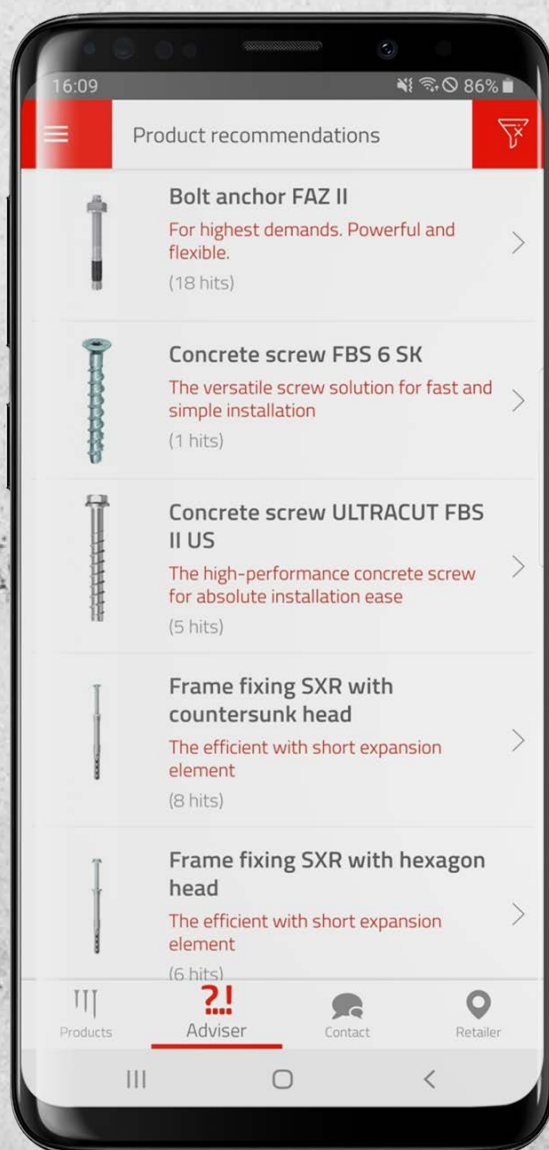

UltraCut FBS II

8, 10 and 12 non-corrosive steel R

The high-performance concrete screw for absolute installation ease in the exterior area.

Unique saw-tooth geometry cuts quickly into the concrete – also in reinforced concrete.

The UltraCut FBS II R is available in different head designs. Countersunk (SK) and hexagonal head (US).



UltraCut FBS II 10x100 US R

The specially hardened red tip provides faster and more secure installation.

The short UltraCut FBS II R, with a reduced embedment depth, allows for a short drill hole depth, fast installation and less reinforcement hits.



UltraCut FBS II 10x60 US R



The countersunk head is suitable for visually appealing installations.

The ribs under the head prevent accidental loosening of the anchor making the system more secure.

Advantages and functions

Your advantages at a glance

- With up to 3 embedment depths, the UltraCut FBS II allows for the same screw to be used for different component thicknesses.
- Expansion-free anchoring (undercut) allows for lowest edge- and axial spacings.
- The assessment (ETA Option 1) covers the use of single-point anchors in cracked and non-cracked concrete.
- The performance categories seismic C1 and C2 ensure that the strictest of safety standards and earthquake specifications can be fulfilled.
- The approved adjustment for the concrete screws allows the screw to be unscrewed twice for a total length of 20 mm, to place maximum 10 mm packing below the base plate head or to align the attached part, and then to tighten the screw again.
- Drill holes do not need to be cleaned during vertical installation (ceiling and floor).

Functioning

- The UltraCut FBS II R is recommended for the push-through installation.
- The screw is installed correctly when the screw head sits flush on the fixture and cannot be screwed in deeper (visual setting control).
- We recommend using a tangential impact wrench with a suitable impact wrench socket (e.g. fischer FSS 18V) or an internal torx drive.
- The assessment document also covers the use of hollow drill with automatic drill hole cleaning and the use of diamond drilling holes.

Approvals



ETA-17/0740,
for cracked concrete



Fire resistance classification
R120



Recommendations

Suitable for building materials, such as



Cracked concrete



Uncracked concrete



Solid brick (masonry)

Installation and applications

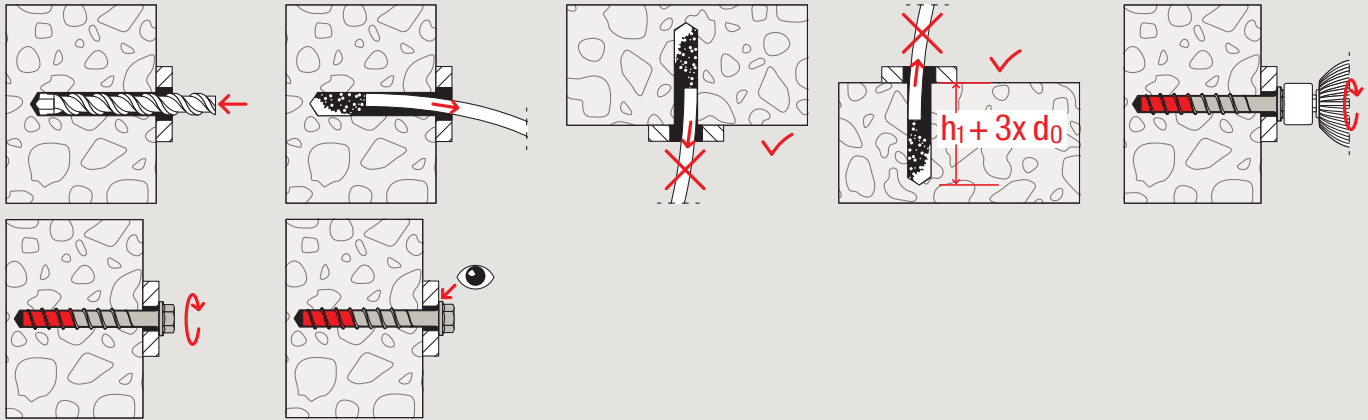

Fixture adjustment

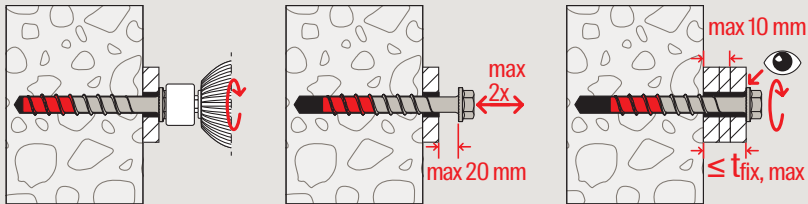

Annular gap filling,

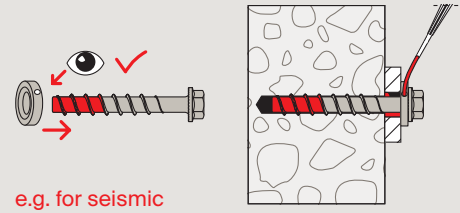

UltraCut FBS II 8, 10 and 12 non-corrosive steel R

Metal construction and outdoor applications



Railings



Brackets / base plates



Canopies



Stadium seating anchoring



Balcony railings



Column footing

Coatings and its base materials



Economic solution: FBS II ZN-plated

Lasting and safe corrosion protection in the dry indoor area. ETA-15/0352 (guarantees a lifetime of 50 years in indoor areas).

The long-lasting one: FBS II CP

Long-lasting coating in comparison with the FBS II ZN-plated (among other things with an external test report for the salt spray chamber mist test of 2.000h).

The extremely durable: FBS II R

Extremely long-lasting and weather-resistant material. The durable solution for the exterior area (ETA 17/0740 guarantees 50 years in the exterior area).

UltraCut FBS II zinc-plated steel as concrete-concrete connector



UltraCut FBS II
ZN-plated



Setting tool SC-ST

Your advantages at a glance

- ETA-approval for the fixing of FBS II as a top concrete or concrete-concrete connector for the strengthening of bridges or old buildings.
- Due to the optional setting tool SC-ST the distance of 40 mm to the existing concrete can be easily reached and an ETA-conform, error-free installation of the FBS II is guaranteed.
- Depending on the diameter of the FBS II three embedment depths are possible.

Functioning

- The UltraCut FBS II is mounted with a tangential impact wrench (e.g. the fischer FSS 18V) and the setting tool SC-ST. As soon as the setting tool sits flush to the concrete surface the correct distance is reached and the installation is finally done.

Concrete-concrete connections



Bridge reinforcement



Parking garage reinforcement

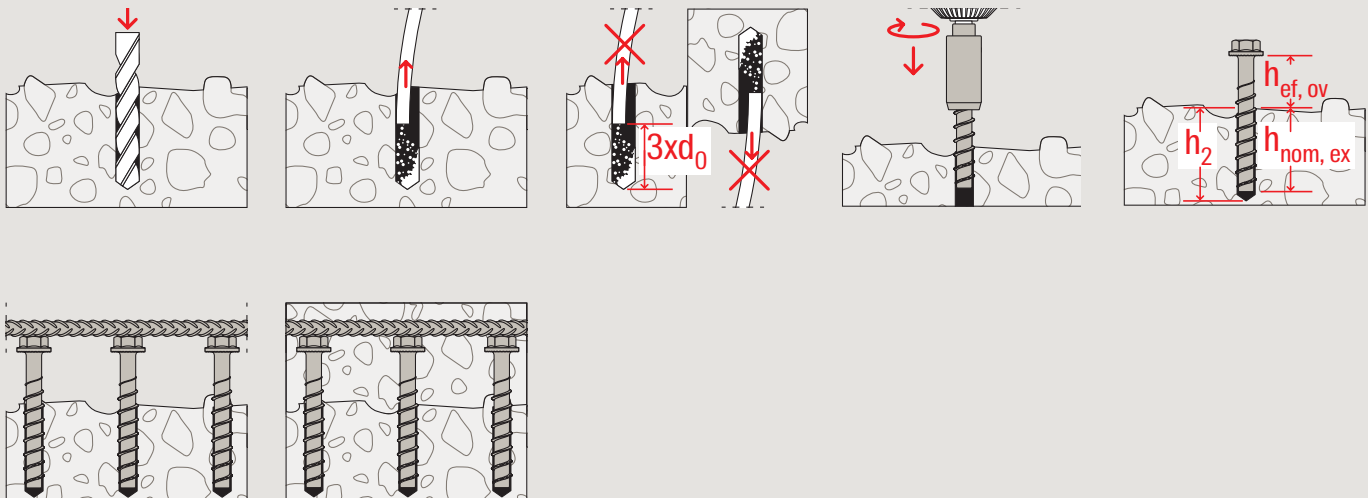

UltraCut FBS II 10 zinc-plated steel with adjusting washer FSW



UltraCut FBS II 10
ZN-plated



Adjusting washer FSW

Your advantages at a glance

- Together with the adjusting disc and the fischer UltraCut FBS II 10 concrete screw wooden beams and wooden sleepers can be adjusted easily and quickly.
- The adjustment process is simplified, so that the support of a second person is not required.
- The adjusting disc is attached to the wooden beam using commonly available screws (recommendation: fischer Power-Fast FPF-PT 5x40, Art. no. 652880).
- After the installation the space under the wood should be injected with mortar.

Functioning

- After the installation of the concrete screw with two adjusting discs FSW the FBS II can easily be loosened, to place maximum 10 mm packing below the wooden beam, and fixed again.
- For installation a tangential impact wrench (e.g. the fischer FSS 18V) with a suitable impact wrench socket or an internal torx drive is recommended.

Timber construction



Wooden sleepers adjustment



Wooden beams adjustment

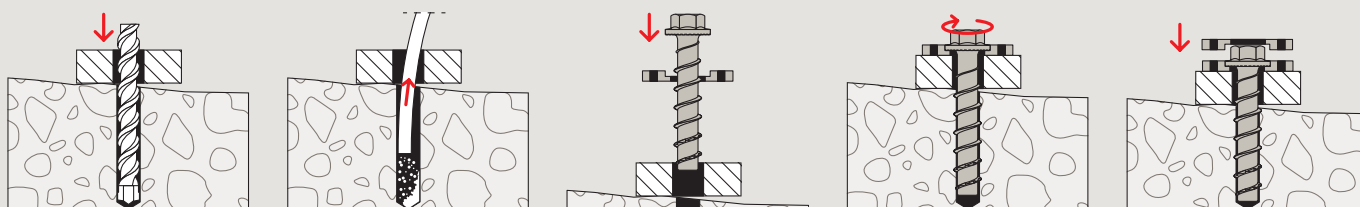

Optional dismantling of the FSW

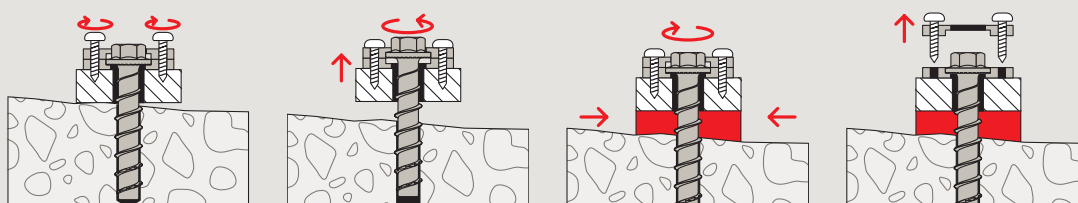

The specialists for concrete screws

Robust die-cast aluminium casing for optimal heat conduction and durability.



FSS 18V 600

Powerful rechargeable battery 4.0 Ah with lithium-ion power and integrated capacity display for checking the charging status.

Belt hook for a comfortable transport of the cordless impact wrench.

Brushless motor for smooth and fast assembly process.



FSS 18V 400 BL

Compatible battery with all other CAS (Cordless Alliance System) devices.

The 12 settings allow the torque of the cordless impact wrench to be individually adapted to the application.

Working light for optimum illumination of the working area.

Compatible battery with all other CAS (Cordless Alliance System) devices.

Cordless Alliance System



Advantages and functions

Advantages at a glance

- The fischer cordless impact wrenches FSS 18V are compatible with all Cordless Alliance System (CAS) chargers and rechargeable batteries worldwide.
- The 12 levels of regulation allow the torque of the cordless impact wrench FSS 18V 400 BL to be individually adapted to the application.
- The brushless motor of the tangential impact wrench FSS 18V 400 BL has an overheat protection that increases safety while reducing downtime and wear.
- The fischer cordless impact wrenches FSS 18V guarantee low vibration despite an extremely high torque.
- The additionally accessories supplied as sockets and checking gauges, enable ease of installation and checking for reusability of the concrete screws FBS II zinc-plated steel.
- The universal fischer service concept offers a seamless repair process worldwide.

Functioning

- The fischer cordless impact wrenches FSS 18V are suitable for the installation of fischer UltraCut concrete screws of all diameters.
- Depending on the head shape of the concrete screw, either an appropriate socket or a special bit TX is recommended for the installation.
- The concrete screw is first screwed in and then tightened by the percussion mechanism.
- If the screw head is in contact with the attachment, correct assembly of the concrete screw is guaranteed (optical setting check).

Concrete screw installation with the fischer cordless impact wrench FSS 18V

The UltraCut FBS II is suitable for push-through installation. For vertical mounting (in ceilings and floor) no drill hole cleaning is necessary, only for drill holes in the floor 3x deeper than the drill hole diameter must be drilled.

In the European Technical Assessment the use of hollow drills (with automatic borehole cleaning) and diamond drilled boreholes are regulated.

For mounting, the fischer cordless impact wrench FSS 18V with corresponding socket or special bit with internal star drive – TX is recommended.

With the screw head resting against the anchor plate surface, so that the screw can no longer be screwed in any further, the correct assembly of the screw is guaranteed (optical setting control).

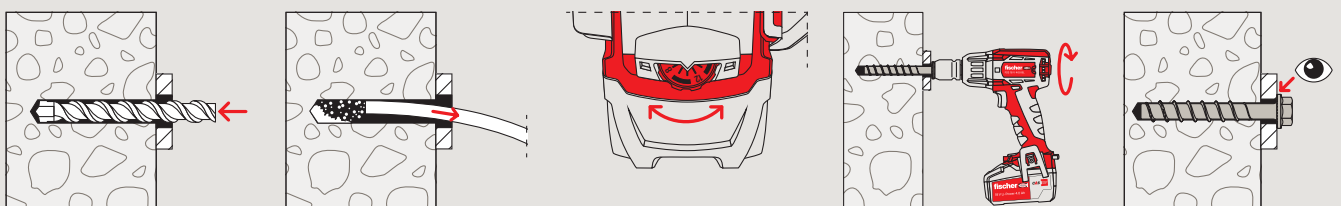

Assortment and technical data

Assortment

Range: Cordless impact wrench FSS 18V 400 BL and FSS 18V 600



FSS Set		FSS 18V 400 BL		FSS 18V 600		FSS-B battery 4.0 Ah		FSS-BC battery charger, air-cooled			
Article description	Art.-No	Belt hook FSS BH	Socket		Checking gauge FUP for concrete screw diameter		Battery 4.0		Battery charger	Packaging	
			[SW] 10/13/15	15/17/21	8/10	12/14	[Ah] 1x	2x			TypeEU
FSS 18V 400 BL	Set 1	552922	●	●	–	●	–	–	–	–	●
	Set 2	552924	●	●	–	●	–	●	–	–	●
	Set 3	552926	●	●	–	●	–	–	●	●	●
FSS 18V 600	Set 1	552923	●	–	●	–	●	–	–	–	●
	Set 2	552925	●	–	●	–	●	●	–	–	●
	Set 3	552927	●	–	●	–	●	–	●	●	●

Technical data

Cordless impact wrench FSS 18V 400 BL and FSS 18V 600										
Article description	Battery voltage [V]	Max. idle speed [min]	Max. number of strokes [min]	Max. torque [Nm]	Torque levels	Tool mounting	Vibration impact screws [m/s ²]	Sound power level ³⁾ [dB (A)]	Sound pres- sure level ³⁾ (LwA) [dB (A)]	Weight with battery [kg]
FSS 18V 400 BL	18	0-2150	4250	400	12	Outer squaret ½" (12.70 mm)	12 ¹⁾	111	100	1.9
FSS 18V 600	18	0-1600	2200	600	1	Outer squaret ½" (12.70 mm)	5.9 ²⁾	107	96	3.1

1) Measurement uncertainty K → 1.5 m/s²2) Measurement uncertainty K → 5.9 m/s²

3) Measurement uncertainty K → 3.0 dB(A)

Assortment & technical data

Battery FSS-B 18V 4.0 Ah and battery charger FSS-BC 12-36V													
Article description	Art.-No	CAS-com- patible	Type of battery	Battery capacity [Ah]	Mains voltage [V]	Mains fre- quency [Hz]	Max. charge amperage [A]	Mains plug type	Weight of battery [g]	Suitable for battery voltage [V]	Environmental con- ditions		Vibration & shock impact [G]
											Storage & Processing	Air humi- dity	
FSS-B 18V 4.0 Ah	552930 ¹⁾	●	Lithium-Ion	4.0	–	–	–	–	670	–	–20 – +60	< 90	< 5
FSS-BC 12-36V EU	552931 ¹⁾	●	–	–	230 – 240	50 – 60	3	(EU)	–	12 – 36	–	–	–
FSS-BC 12-36V UK	552932 ¹⁾	●	–	–	230 – 240	50 – 60	3	(UK)	–	12 – 36	–	–	–

1) Battery may only be charged with fischer or CAS chargers.

Assortment

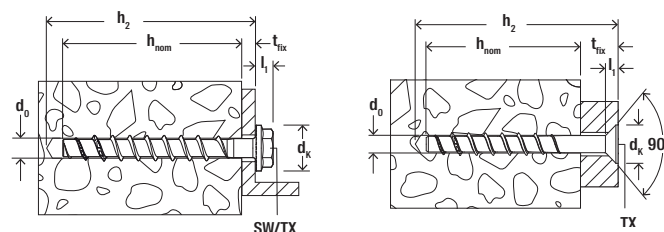

Concrete screw UltraCut FBS II galvanised steel



UltraCut FBS II - US (TX) - hexagon head

UltraCut FBS II - SK - countersunk head

Item	Art.-No.	Ap- proval	Nominal drill-Ø	Minimum drill depth at push-through mode	Screws outer diameter x length	Screwing depth						Width across flat / internal torx drive	Sales unit
						h _{nom,1} [mm]	t _{fix,1} [mm]	h _{nom,2} [mm]	t _{fix,2} [mm]	h _{nom,3} [mm]	t _{fix,3} [mm]		
FBS II 8x55 5/- US TX	536851	●	8	65	10x55	50	5	-	-	-	-	13/40	50
FBS II 8x70 20/5 US TX	536852	●	8	80	10x70	50	20	-	-	65	5	13/40	50
FBS II 8x80 30/15 US TX	536853	●	8	90	10x80	50	30	-	-	65	15	13/40	50
FBS II 8x90 40/25 US TX	536854	●	8	100	10x90	50	40	-	-	65	25	13/40	50
FBS II 8x100 50/35 US TX	536855	●	8	110	10x100	50	50	-	-	65	35	13/40	50
FBS II 8x110 60/45 US TX	536856	●	8	120	10x110	50	60	-	-	65	45	13/40	50
FBS II 8x130 80/65 US TX	536857	●	8	140	10x130	50	80	-	-	65	65	13/40	50
FBS II 8x150 100/85 US TX	558219	●	8	160	10x150	50	100	-	-	65	85	13/40	50
FBS II 8x170 120/105 US TX	558220	●	8	180	10x170	50	120	-	-	65	105	13/40	50
FBS II 8x190 140/125 US TX	558221	●	8	200	10x190	50	140	-	-	65	125	13/40	20
FBS II 10x60 5/-/- US	536858	●	10	70	12x60	55	5	-	-	-	-	15	50
FBS II 10x70 15/5/- US	536859	●	10	80	12x70	55	15	65	5	-	-	15	50
FBS II 10x80 25/15/- US	536860	●	10	90	12x80	55	25	65	15	-	-	15	50
FBS II 10x90 35/25/5 US	536861	●	10	100	12x90	55	35	65	25	85	5	15	50
FBS II 10x100 45/35/15 US	536862	●	10	110	12x100	55	45	65	35	85	15	15	50
FBS II 10x120 65/55/35 US	536863	●	10	130	12x120	55	65	65	55	85	35	15	50
FBS II 10x140 85/75/55 US	536864	●	10	150	12x140	55	85	65	75	85	55	15	50
FBS II 10x160 105/95/75 US	536865	●	10	170	12x160	55	105	65	95	85	75	15	50
FBS II 10x200 145/135/115 US	536866	●	10	210	12x200	55	145	65	135	85	115	15	20
FBS II 10x230 175/165/145 US	536867	●	10	240	12x230	55	175	65	165	85	145	15	20
FBS II 10x260 205/195/175 US	536868	●	10	270	12x260	55	205	65	195	85	175	15	20
FBS II 10x280 225/215/195 US	558222	●	10	290	12x280	55	225	65	215	85	195	15	20
FBS II 12x70 10/-/- US	536869	●	12	80	14x70	60	10	-	-	-	-	17	20
FBS II 12x85 25/10/- US	536870	●	12	95	14x85	60	25	75	10	-	-	17	20
FBS II 12x110 50/35/10 US	536871	●	12	120	14x110	60	50	75	35	100	10	17	20
FBS II 12x130 70/55/30 US	536872	●	12	140	14x130	60	70	75	55	100	30	17	20
FBS II 12x150 90/75/50 US	536873	●	12	160	14x150	60	90	75	75	100	50	17	20
FBS II 12x170 110/95/70 US	558223	●	12	180	14x170	60	110	75	95	100	70	17	20
FBS II 12x190 130/115/90 US	558224	●	12	200	14x190	60	130	75	115	100	90	17	20
FBS II 12x210 150/135/110 US	558225	●	12	220	14x210	60	150	75	135	100	110	17	20
FBS II 14x75 10/-/- US	536874	●	14	90	16x75	65	10	-	-	-	-	21	20
FBS II 14x95 30/10/- US	536875	●	14	110	16x95	65	30	85	10	-	-	21	20

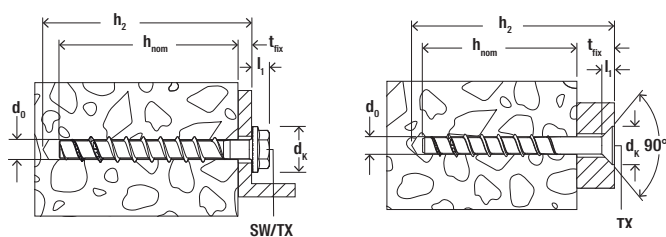

Concrete screw UltraCut FBS II galvanised steel



UltraCut FBS II - US (TX) - hexagon head

UltraCut FBS II - SK - countersunk head

Item	Art.-No.	Approval	Nominal drill-Ø		Minimum drill depth at push-through mode	Screws outer diameter x length	Screwing depth						Width across flat / internal torx drive	Sales unit
			zinc-plated steel	ETA			d ₀ [mm]	h ₂ [mm]	h _{nom,1} [mm]	t _{fix,1} [mm]	h _{nom,2} [mm]	t _{fix,2} [mm]		
FBS II 14x100 35/15/- US	536876	●	14	115	16x100	65	35	85	15	-	-	21	20	
FBS II 14x125 60/40/10 US	536877	●	14	140	16x125	65	60	85	40	115	10	21	10	
FBS II 14x150 85/65/35 US	536878	●	14	165	16x150	65	85	85	65	115	35	21	10	
FBS II 14x180 115/85/65 US	558226	●	14	195	16x180	65	115	85	95	115	65	21	10	
FBS II 14x210 145/125/95 US	558227	●	14	225	16x210	65	145	85	125	115	95	21	10	
FBS II 14x240 175/155/125 US	558228	●	14	255	16x240	65	175	85	155	115	125	21	10	
FBS II 8x60 10/- SK	536880	●	8	70	10x60	50	10	-	-	-	-	40	50	
FBS II 8x80 30/15 SK	536881	●	8	90	10x80	50	30	-	-	65	15	40	50	
FBS II 8x90 40/25 SK	536882	●	8	100	10x90	50	40	-	-	65	25	40	50	
FBS II 8x100 50/35 SK	558229	●	8	110	10x100	50	50	-	-	65	35	40	50	
FBS II 8x110 60/45 SK	558230	●	8	120	10x110	50	60	-	-	65	45	40	50	
FBS II 8x120 70/55 SK	558231	●	8	130	10x120	50	70	-	-	65	55	40	50	
FBS II 8x140 90/75 SK	558232	●	8	150	10x140	50	90	-	-	65	75	40	50	
FBS II 8x160 110/95 SK	558233	●	8	170	10x160	50	110	-	-	65	95	40	50	
FBS II 8x180 130/115 SK	558234	●	8	190	10x180	50	130	-	-	65	115	40	20	
FBS II 8x200 150/135 SK	558235	●	8	210	10x200	50	150	-	-	65	135	40	20	
FBS II 10x65 10/-/- SK	536884	●	10	75	12x65	55	10	-	-	-	-	50	50	
FBS II 10x80 25/15/- SK	536885	●	10	90	12x80	55	25	65	15	-	-	50	50	
FBS II 10x95 40/30/10 SK	536886	●	10	105	12x95	55	40	65	30	85	10	50	50	
FBS II 10x100 45/35/15 SK	536887	●	10	110	12x100	55	45	65	35	85	15	50	50	
FBS II 10x120 65/55/35 SK	536888	●	10	130	12x120	55	65	65	55	85	35	50	50	
FBS II 10x140 85/75/55 SK	558236	●	10	150	12x140	55	85	65	75	85	55	50	50	
FBS II 10x160 105/95/75 SK	558237	●	10	170	12x160	55	105	65	95	85	75	50	50	
FBS II 10x180 125/115/95 SK	558238	●	10	190	12x180	55	125	65	115	85	95	50	20	

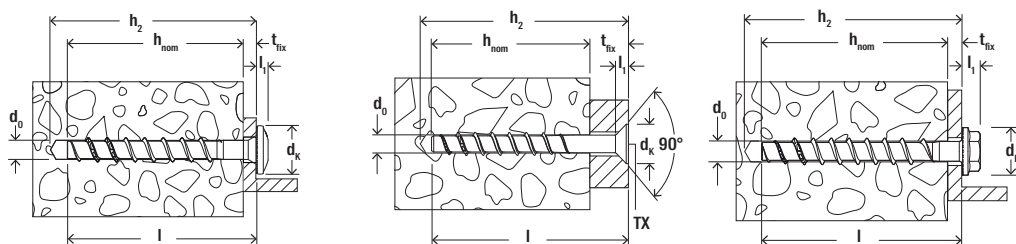

Concrete screw UltraCut FBS II

UltraCut FBS II 6 P/LP
panheadUltraCut FBS II 6 SK
countersunk headUltraCut FBS II 6 US
hexagon head

Item	Art.-No.	Ap- prov- al	Nominal drill-Ø d ₀ [mm]	Minimum drill depth at push- through mode h ₂ [mm]	Screws outer diameter x length [mm]	Screwing depth		Width across flat / internal torx drive [SW/TX]	Sales unit [pcs]	
						screwing depth	usable length			
	zinc-plat- ed steel	ETA				Multiple fixing ETA- 18/0242 h _{nom,max} - h _{nom,min} [mm]	Single fixing ETA- 15/0352 h _{nom,min} - h _{nom,max} [mm]	t _{fix,max} - t _{fix,min} [mm]		
FBS II 6x30/5 P	546377	●	6	40	7,5 x 30	25	-	Screw length - h _{nom}	TX 30	100
FBS II 6x40/5 P	546378	●	6	50	7,5 x 40	25-35	-	Screw length - h _{nom}	TX 30	100
FBS II 6x40/5 LP	546379	●	6	50	7,5 x 40	25-35	-	Screw length - h _{nom}	TX 30	100
FBS II 6x60/5 P	546380	●	6	70	7,5 x 60	25-55	40-55	Screw length - h _{nom}	TX 30	100
FBS II 6x80/25 P	546381	●	6	90	7,5 x 80	25-55	40-55	Screw length - h _{nom}	TX 30	100
FBS II 6x30/5 SK	546382	●	6	40	7,5 x 30	25	-	Screw length - h _{nom}	TX 30	100
FBS II 6x40/5 SK	546383	●	6	50	7,5 x 40	25-35	-	Screw length - h _{nom}	TX 30	100
FBS II 6x60/5 SK	546384	●	6	70	7,5 x 60	25-55	40-55	Screw length - h _{nom}	TX 30	100
FBS II 6x80/25 SK	546385	●	6	90	7,5 x 80	25-55	40-55	Screw length - h _{nom}	TX 30	100
FBS II 6x100/45 SK	546386	●	6	110	7,5 x 100	25-55	40-55	Screw length - h _{nom}	TX 30	100
FBS II 6x120/65 SK	546387	●	6	130	7,5 x 120	25-55	40-55	Screw length - h _{nom}	TX 30	100
FBS II 6x140/85 SK	546388	●	6	150	7,5 x 140	25-55	40-55	Screw length - h _{nom}	TX 30	100
FBS II 6x160/105 SK	546389	●	6	170	7,5 x 160	25-55	40-55	Screw length - h _{nom}	TX 30	100
FBS II 6x40/5 US	546390	●	6	50	7,5 x 40	25-35	-	Screw length - h _{nom}	SW 10	100
FBS II 6x60/5 US	546391	●	6	70	7,5 x 60	25-55	40-55	Screw length - h _{nom}	SW 10	100
FBS II 6x80/25 US	546392	●	6	90	7,5 x 80	25-55	40-55	Screw length - h _{nom}	SW 10	100
FBS II 6x100/45 US	546393	●	6	110	7,5 x 100	25-55	40-55	Screw length - h _{nom}	SW 10	100
FBS II 6x120/65 US	546394	●	6	130	7,5 x 120	25-55	40-55	Screw length - h _{nom}	SW 10	100

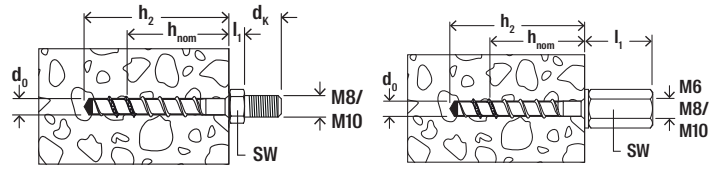

Concrete screw UltraCut FBS II 6



UltraCut FBS II 6 M8/19 hanger bolt

UltraCut FBS II 6 M6 I; M8/M10 I connection sleeve

Item	Art.-No.	Ap- pro- val	Nominal drill-Ø d ₀ [mm]	Minimum drill depth at pre-positioned mode h ₂ [mm]	Screws outer diameter x length [mm]	Screwing depth		Width across flat [SW]	Sales unit [pcs]
						Multiple fixing ETA-18/0242 h _{nom} [mm]	Single fixing ETA-15/0352 h _{nom} [mm]		
FBS II 6x25 M8/19	546395	●	6	30	7,5x25	25	-	SW 10	100
FBS II 6x35 M8/19	546396	●	6	40	7,5x35	35	-	SW 10	100
FBS II 6x55 M8/19	546397	●	6	60	7,5x55	55	55	SW 10	100
FBS II 6x35 M10/21	546398	●	6	40	7,5x35	35	-	SW 13	100
FBS II 6x55 M10/21	546399	●	6	60	7,5x55	55	55	SW 13	100
FBS II 6x35 M6 I	554065	●	6	40	7,5x35	35	-	SW 13	100
FBS II 6x55 M6 I	554066	●	6	60	7,5x55	55	55	SW 13	100
FBS II 6x35 M8/M10 I	546400	●	6	40	7,5x35	35	-	SW 13	100
FBS II 6x55 M8/M10 I	546401	●	6	60	7,5x55	55	55	SW 13	100

Optional installation of the fischer concrete screw with an cordless screwdriver.

Possible installation using a standard, high-performance cordless screwdriver if the ideal FSS 18V impact wrench ideal the application is not available.

Advantages:

- No need to purchase additional equipment for a few installations if a cordless screwdriver is already available.
- Lower noise level compared to the impact wrench.

⚠ ATTENTION Hand twisting is possible or great strain on the wrist will occur!

Diameter x screw depth [h _{nom}]	Concrete Grade C 20/25		Concrete Grade C 50/60	
	Installation with new drill	Installation with used drill	Installation with new drill	Installation with used drill
	centre square of drill bit (BEM: 6,25mm)	centre square of drill bit (BEM: 6,25mm)	centre square of drill bit (BEM: 6,25mm)	centre square of drill bit (BEM: 6,25mm)
FBS II 6x25	suitable	suitable	suitable	suitable
FBS II 6x30	suitable	suitable	suitable	suitable
FBS II 6x35	suitable	suitable	suitable	-
FBS II 6x40	suitable	suitable	suitable	-

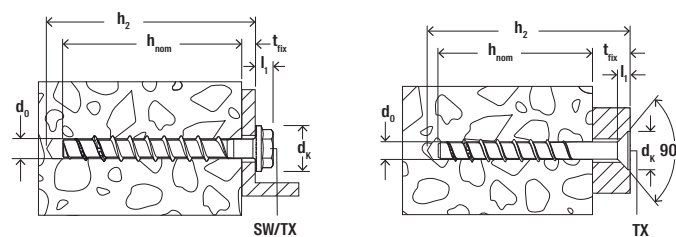

Concrete screws UltraCut FBS II 8, 10, 12 and 14 CP



UltraCut FBS II CP - US - hexagon head



UltraCut FBS II CP - SK - countersunk head

Item	Art.-No.	Approval	Nominal drill-Ø	Minimum drill depth at push-through mode	Screws outer diameter x length	Screwing depth						Width across flat / internal torx drive	Sales unit
						$h_{nom,1}$	$t_{fix,1}$	$h_{nom,2}$	$t_{fix,2}$	$h_{nom,3}$	$t_{fix,3}$		
	Corrosion protection		d_0	h_2	[mm]	[mm]	[mm]	[mm]	[mm]	[mm]	[mm]	[SW/TX]	[pcs]
	CP	ETA	[mm]	[mm]									
FBS II CP 8x55 5/- US TX	557781	●	8 mm	65	10x55	50	5	-	-	-	-	13/40	50
FBS II CP 8x70 20/5 US TX	557782	●	8 mm	80	10x70	50	20	-	-	65	5	13/40	50
FBS II CP 8x80 30/15 US TX	557783	●	8 mm	90	10x80	50	30	-	-	65	15	13/40	50
FBS II CP 8x90 40/25 US TX	557784	●	8 mm	100	10x90	50	40	-	-	65	25	13/40	50
FBS II CP 8x100 50/35 US TX	557785	●	8 mm	110	10x100	50	50	-	-	65	35	13/40	50
FBS II CP 10x60 5/-/- US	557786	●	10 mm	70	12x60	55	5	-	-	-	-	15	50
FBS II CP 10x70 15/5/- US	557787	●	10 mm	80	12x70	55	15	65	5	-	-	15	50
FBS II CP 10x80 25/15/- US	557788	●	10 mm	90	12x80	55	25	65	15	-	-	15	50
FBS II CP 10x90 35/25/5 US	557789	●	10 mm	100	12x90	55	35	65	25	85	5	15	50
FBS II CP 10x100 45/35/15 US	557790	●	10 mm	110	12x100	55	45	65	35	85	15	15	50
FBS II CP 10x120 65/55/35 US	557791	●	10 mm	130	12x120	55	65	65	55	85	35	15	50
FBS II CP 10x140 85/75/55 US	557792	●	10 mm	150	12x140	55	85	65	75	85	55	15	50
FBS II CP 10x160 105/95/75 US	557793	●	10 mm	170	12x160	55	105	65	95	85	75	15	50
FBS II CP 12x85 25/10/- US	557794	●	12 mm	95	14x85	60	25	75	10	-	-	17	20
FBS II CP 12x110 50/35/10 US	557795	●	12 mm	120	14x110	60	50	75	35	100	10	17	20
FBS II CP 14x75 10/-/- US	557796	●	14 mm	90	16x75	65	10	-	-	-	-	21	20
FBS II CP 14x95 30/10/- US	557797	●	14 mm	110	16x95	65	30	85	10	-	-	21	20
FBS II CP 14x100 35/15/- US	557798	●	14 mm	115	16x100	65	35	85	15	-	-	21	20
FBS II CP 14x125 60/40/10 US	557799	●	14 mm	140	16x125	65	60	85	40	115	10	21	10
FBS II CP 8x60 10/- SK	557800	●	8 mm	70	10x60	50	10	-	-	-	-	40	50
FBS II CP 8x80 30/15 SK	557801	●	8 mm	90	10x80	50	30	-	-	65	15	40	50
FBS II CP 8x90 40/25 SK	557802	●	8 mm	100	10x90	50	40	-	-	65	25	40	50
FBS II CP 10x65 10/-/- SK	557803	●	10 mm	75	12x65	55	10	-	-	-	-	50	50
FBS II CP 10x80 25/15/- SK	557804	●	10 mm	90	12x80	55	25	65	15	-	-	50	50
FBS II CP 10x100 45/35/15 SK	557805	●	10 mm	110	12x100	55	45	65	35	85	15	50	50

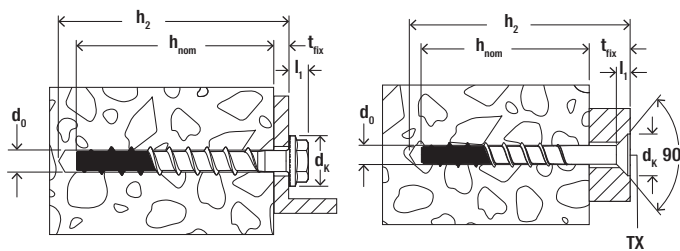

Concrete screw UltraCut FBS II R



UltraCut FBS II R - US - hexagonal head

UltraCut FBS II R - SK - countersunk head

Item	Art.-No	Approval	Nominal drill-Ø	Minimum drill depth at push-through mode	Screws outer diameter x length	Screwing depth						Width across flat / internal torx drive	Sales unit
						h _{nom,1}	t _{fix,1}	h _{nom,2}	t _{fix,2}	h _{nom,3}	t _{fix,3}		
	R	ETA	d ₀ [mm]	h ₂ [mm]	[mm]	[mm]	[mm]	[mm]	[mm]	[mm]	[mm]	[SW/TX]	[pcs]
FBS II 8x60 10/- US R	543565	●	8	70	10x60	50	10	-	-	-	-	13	50
FBS II 8x70 20/5 US R	543566	●	8	80	10x70	50	20	-	-	65	5	13	50
FBS II 8x80 30/15 US R	543567	●	8	90	10x80	50	30	-	-	65	15	13	50
FBS II 8x90 40/25 US R	543568	●	8	100	10x90	50	40	-	-	65	25	13	50
FBS II 8x100 50/35 US R	558239	●	8	110	10x100	50	50	-	-	65	35	13	50
FBS II 8x120 70/55 US R	558240	●	8	130	10x120	50	70	-	-	65	55	13	50
FBS II 8x140 90/75 US R	558241	●	8	150	10x140	50	90	-	-	65	75	13	50
FBS II 8x160 110/95 US R	558242	●	8	170	10x160	50	110	-	-	65	95	13	50
FBS II 10x60 5/-/- US R	543569	●	10	70	12x60	55	5	-	-	-	-	15	50
FBS II 10x70 15/5/- US R	543570	●	10	80	12x70	55	15	65	5	-	-	15	50
FBS II 10x80 25/15/- US R	543571	●	10	90	12x80	55	25	65	15	-	-	15	50
FBS II 10x90 35/25/5 US R	543572	●	10	100	12x90	55	35	65	25	85	5	15	50
FBS II 10x100 45/35/15 US R	543573	●	10	110	12x100	55	45	65	35	85	15	15	50
FBS II 10x120 65/55/35 US R	543574	●	10	130	12x120	55	65	65	55	85	35	15	50
FBS II 10x140 85/75/55 US R	558243	●	10	150	12x140	55	85	65	75	85	55	15	50
FBS II 10x160 105/95/75 US R	558244	●	10	170	12x160	55	105	65	95	85	75	15	50
FBS II 12x70 10/-/- US R	543575	●	12	80	14x70	60	10	-	-	-	-	17	20
FBS II 12x85 25/10/- US R	543576	●	12	95	14x85	60	25	75	10	-	-	17	20
FBS II 12x110 50/35/10 US R	543577	●	12	120	14x110	60	50	75	35	100	10	17	20
FBS II 12x130 70/55/30 US R	543578	●	12	140	14x130	60	70	75	55	100	30	17	20
FBS II 12x160 100/85/60 US R	558245	●	12	170	14x160	60	100	75	85	100	60	17	20
FBS II 8x60 10/- SK R	543579	●	8	70	10x60	50	10	-	-	-	-	TX 40	50
FBS II 8x80 30/15 SK R	543580	●	8	90	10x80	50	30	-	-	65	15	TX 40	50
FBS II 8x90 40/25 SK R	543581	●	8	100	10x90	50	40	-	-	65	25	TX 40	50
FBS II 8x100 50/35 SK R	558246	●	8	110	10x100	50	50	-	-	65	35	TX 40	50
FBS II 8x120 70/55 SK R	558915	●	8	120	10x120	50	70	-	-	65	35	TX 40	50
FBS II 10x65 10/-/- SK R	543582	●	10	75	12x65	55	10	-	-	-	-	TX 50	50
FBS II 10x80 25/15/- SK R	543583	●	10	90	12x80	55	25	65	15	-	-	TX 50	50
FBS II 10x95 40/30/10 SK R	543584	●	10	105	12x95	55	40	65	30	85	10	TX 50	50
FBS II 10x100 45/35/15 SK R	543585	●	10	110	12x100	55	45	65	35	85	15	TX 50	50
FBS II 10x120 65/55/35 SK R	543586	●	10	130	12x120	55	65	65	55	85	35	TX 50	50

Additional assortment

Complement for UltraCut FBS II

Item	Art.-No.	Internal-Ø [mm]	External-Ø [mm]	Drive	Suitable for UltraCut FBS II [SW/TX]	Sales unit [Stück]
Checking gauge FUP						
Nut SW						
Nut TX						
FMB TX 40 Maxx Bit						
Profi-Bit FPB TX 50 5/16"						
Filling washer FFD						
Washer FSW 10						
Setting tool SC-ST						
Washer U						
Checking gauge FUP 8	537200	9,9	-	-	FBS II 8	1
Checking gauge FUP 10	537201	12,0	-	-	FBS II 10	1
Checking gauge FUP 12	537202	13,9	-	-	FBS II 12	1
Checking gauge FUP 14	537203	15,6	-	-	FBS II 14	1
Nut SW 10	538577	-	-	1/2"/SW 10	FBS II 6	1
Nut SW 13	538578	-	-	1/2"/SW 13	FBS II 6/FBS II 8	1
Nut SW 15	538579	-	-	1/2"/SW 15	FBS II 10	1
Nut SW 17	538580	-	-	1/2"/SW 17	FBS II 12	1
Nut SW 21	538581	-	-	1/2"/SW 21	FBS II 14	1
Nut TX ¹⁾	538575	-	-	1/2"-1/4"	FBS II 8/FBS II 8 SK + FBS II 6	1
Nut TX50 ²⁾	553928	-	-	1/2"-5/16"	FBS II 10/FBS II 10 SK	1
FMB TX 30 Maxx Bit W5	533158	-	-	TX 30	FBS II 6	5
FMB TX 40 Maxx Bit W 5	533159	-	-	TX 40	FBS II 8/FBS II 8 SK	5
FPB Profi-Bit T 50 5/16"	538574	-	-	TX 50	FBS II 10 SK	1
FFD 22x9x6	547515	9	22	-	FBS II 6	4
FFD 26x12x6	538458	12	26	-	FBS II 8	4
FFD 26x12x6 R	541986	12	26	-	FBS II 8 R	4
FFD 30x14x6	538459	14	30	-	FBS II 10/FBS II 12	4
FFD 30x14x6 R	541987	14	30	-	FBS II 10 R/FBS II 12 R	4
FFD 38x19x7	538460	19	38	-	FBS II 14	4
Adjusting washer FSW 10 ³⁾	557276	-	-	-	FBS II 10	40
Setting tool SC-ST 8	557872	-	-	-	FBS II 8 US	1
Setting tool SC-ST 10	557874	-	-	-	FBS II 10 US	1
Washer for FBS II 10	520471	13,5	44	-	FBS II 10	50

1) Suitable for FMB TX 40 Maxx Bit and FMB TX 30 Maxx Bit

2) Suitable for FPB Profi-Bit TX 50 5/16"

3) Mountable with Power-Fast PPF-PT 5x40 (652880)

Filling disc for UltraCut FBS II / FBS II CP / FBS II R

By using the backfilling disc, a backlash, e.g. in the case of shear forces, can be ruled out. For this purpose, the filling disc is placed on the concrete screw before installation (recess to the component).

In the next step, the FBS II is screwed in until the filling disc rests against the anchor plate. Now the filling with one of the injection

mortars FIS HB, FIS V, FIS SB or FIS EM Plus can be carried out through the lateral bore using the filling aid. The filling quantity depends on the thickness of the anchor plate and the size of the annular gap.

Typical fields of application are brackets, earthquake-approved anchorings

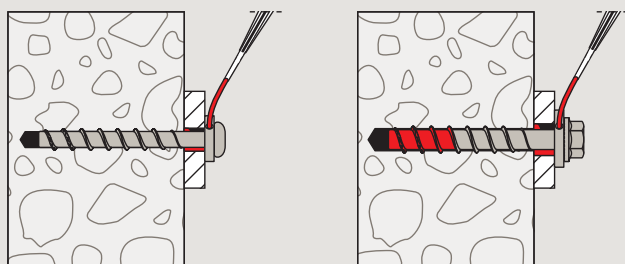

Loads

Typ US

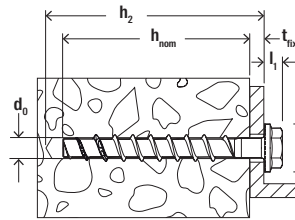

Typ I

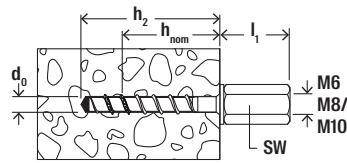

Typ P

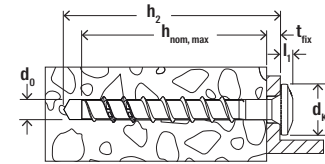

Typ SK

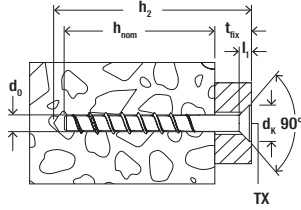

	l_1 [mm]	d_k [mm]
UltraCut FBS II 8 SK	6,0	20,0
UltraCut FBS II 10 SK	7,0	23,0
UltraCut FBS II 6 SK	6,0	13,5
UltraCut FBS II 6 P	3,9	14,4
UltraCut FBS II 6 LP	3,6	17,5
UltraCut FBS II 6 US	6,4	17,0
UltraCut FBS II M8/M10	3,6/5	15/16
UltraCut FBS II 6 I M8/M10; M6	37,0/32	-

Typ M8/M10

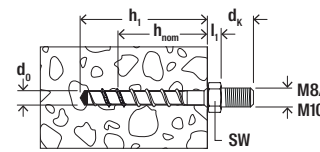

Typ LP

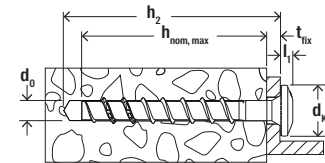

Concrete screw UltraCut FBS II 6-14 zinc-plated steel / R

Installation parameters concrete

Concrete screw UltraCut FBS II 6-14 zinc-plated steel / R	Drill hole diameter d_0 [mm]	Nominal screw-in depth			Drill hole depth (push-through instal- lation) $h_2 \geq$ [mm]	Clearance hole diameter d_f [mm]	Maximum torque for installation with impact screw driver in concrete ¹⁾		Width across flat SW	Drive TX
		h_{nom1} [mm]	h_{nom2} [mm]	h_{nom3} [mm]			$T_{imp, max}$ zinc-plated steel [Nm]	$T_{imp, max}$ R [Nm]		
FBS II 6	6	25-55	25-55	25-55	I + 10	≥ 8	450 ¹⁾	-	10 ²⁾	TX 30
FBS II 8	8	50	-	65	I + 10	10,6-12	600	450	13	TX 40 (SK und US)
FBS II 10	10	55	65	85	I + 10	12,8-14	650	450	15	TX 50 (SK)
FBS II 12	12	60	75	100	I + 10	14,8-16	650	650	17	-
FBS II 14	14	65	85	115	I + 15	16,9-18	650	-	21	-

1) Screw-in depth <35 mm 80 Nm.

2) SW 13 at FBS II ... M10 and FBS II ... M8/M10 I.

3) The values apply to concrete strength of approx. 40 N/mm², for other concrete strength classes the values may differ. The conversion of nominal output into effective tightening torque varies from machine to machine - always therefore use torque control.

Installation parameters masonry

Concrete screw UltraCut FBS II 6-10

Base material	Compressive strength class [N/mm ²]	Size		FBS II 6	FBS II 8	FBS II 10
		h_{nom}	[mm]	55	65	85
Solid clay brick (EN771-1)	≥ 12	T_{inst}	[Nm]	2	10	10
Solid sand-lime brick (EN771-2)	≥ 12	T_{inst}	[Nm]	5	15	15
Aerated concrete (EN771-4)	≥ 6	T_{inst}	[Nm]	1.5	5	10

Loads

Concrete screw UltraCut FBS II US hexagon head with integral washer and FBS II SK countersunk head

Permissible loads of a single anchor¹⁾ in normal concrete of strength class C20/25.
For the design the complete current assessment ETA-15/0352 has to be considered.

Type	Material/ surface	Screw-in depth h_{nom} [mm]	Minimum member thickness h_{min} [mm]	Instal- lation torque $T_{imp, max}$ ²⁾ [Nm]	Cracked concrete				Non-cracked concrete			
					Permissible tension (N_{perm}) and shear loads (V_{perm}); minimum spacing (s_{min}) and edge distances (c_{min}) with reduced loads				Permissible tension (N_{perm}) and shear loads (V_{perm}); minimum spacing (s_{min}) and edge distances (c_{min}) with reduced loads			
					N_{perm} ³⁾ [kN]	V_{perm} ³⁾ [kN]	s_{min} ³⁾ [mm]	c_{min} ³⁾ [mm]	N_{perm} ³⁾ [kN]	V_{perm} ³⁾ [kN]	s_{min} ³⁾ [mm]	c_{min} ³⁾ [mm]
FBS II 6	gvz	40	80	450	1.2	4.3	35	35	3.8	4.3	35	35
	gvz	45	90	450	1.7	4.3	35	35	4.8	4.3	35	35
	gvz	50	90	450	1.9	4.3	35	35	5.7	4.3	35	35
	gvz	55	100	450	2.4	6.3	35	35	6.4	6.3	35	35
FBS II 8	gvz / CP	50	100	600	2.9	4.1	35	35	5.9	5.9	35	35
	gvz / CP	65	120	600	5.7	9.0	35	35	8.8	9.0	35	35
FBS II 10	gvz / CP	55	100	650	4.3	4.6	40	40	6.6	6.6	40	40
	gvz / CP	65	120	650	5.7	11.9	40	40	8.5	14.0	40	40
	gvz / CP	85	140	650	9.2	16.6	40	40	13.1	16.6	40	40
FBS II 12	gvz / CP	60	110	650	5.3	10.6	50	50	7.5	15.1	50	50
	gvz / CP	75	130	650	7.6	15.2	50	50	10.9	15.2	50	50
	gvz / CP	100	150	650	12.0	20.3	50	50	17.1	20.3	50	50
FBS II 14	gvz / CP	65	120	650	5.8	11.6	60	60	8.3	16.6	60	60
	gvz / CP	85	140	650	9.0	18.0	60	60	12.8	22.1	60	60
	gvz / CP	115	180	650	14.7	29.4	60	60	21.0	29.4	60	60

¹⁾ Design according to EN 1992-4:2018 (for static resp. quasi-static loads). The partial safety factors for material resistance as regulated in the ETA as well as a partial safety factor for load actions of $\gamma_L = 1.4$ are considered. As a single anchor counts e.g. an anchor with a spacing $s \geq 3 \times h_{ef}$ and an edge distance $c \geq 1.5 \times h_{ef}$. Accurate data see ETA.

²⁾ Maximum allowable torque for installation with any tangential impact screw driver. Further technical data see ETA.

³⁾ In the case of combinations of tensile and shear loads, bending moments with reduced or minimum spacing and edge distances (anchor groups), the design must be carried out in accordance with the provisions of the complete ETA and the provisions of the EN 1992-4:2018. We recommend using our anchor design software C-FIX.

Concrete screw UltraCut FBS II US R hexagon head with integral washer and FBS II SK R countersunk head

Permissible loads of a single anchor¹⁾ in normal concrete of strength class C20/25.
For the design the complete current assessment ETA-17/0740 has to be considered.

Type	Material/ surface	Screw-in depth h_{nom} [mm]	Minimum member thickness h_{min} [mm]	Maximum installation torque $T_{imp, max}$ ²⁾ [Nm]	Cracked concrete				Non-cracked concrete			
					Permissible tension (N_{perm}) and shear loads (V_{perm}); minimum spacing (s_{min}) and edge distances (c_{min}) with reduced loads				Permissible tension (N_{perm}) and shear loads (V_{perm}); minimum spacing (s_{min}) and edge distances (c_{min}) with reduced loads			
					N_{perm} ³⁾ [kN]	V_{perm} ³⁾ [kN]	s_{min} ³⁾ [mm]	c_{min} ³⁾ [mm]	N_{perm} ³⁾ [kN]	V_{perm} ³⁾ [kN]	s_{min} ³⁾ [mm]	c_{min} ³⁾ [mm]
FBS II 8	R	50	100	450	1.9	4.1	35	35	3.3	5.9	35	35
FBS II 8	R	65	120	450	4.3	6.1	35	35	6.7	8.8	35	35
FBS II 10	R	55	100	450	2.1	4.6	40	40	4.0	6.6	40	40
FBS II 10	R	65	120	450	2.9	6.0	40	40	6.7	8.5	40	40
FBS II 10	R	85	140	450	7.6	18.4	40	40	13.1	20.9	40	40
FBS II 12	R	60	110	650	2.1	5.3	50	50	4.8	7.5	50	50
FBS II 12	R	75	130	650	5.2	15.2	50	50	5.7	21.8	50	50
FBS II 12	R	100	150	650	12.0	23.9	50	50	17.1	26.2	50	50

¹⁾ Design according to EN 1992-4:2018 (for static resp. quasi-static loads). The partial safety factors for material resistance as regulated in the ETA as well as a partial safety factor for load actions of $\gamma_L = 1.4$ are considered. As a single anchor counts e.g. an anchor with a spacing $s \geq 3 \times h_{ef}$ and an edge distance $c \geq 1.5 \times h_{ef}$. Accurate data see ETA.

²⁾ Maximum allowable torque for installation with any tangential impact screw driver. Further technical data see ETA.

³⁾ In the case of combinations of tensile and shear loads, bending moments with reduced or minimum spacing and edge distances (anchor groups), the design must be carried out in accordance with the provisions of the complete ETA and the provisions of the EN 1992-4:2018. We recommend using our anchor design software C-FIX.

Loads

Concrete screw UltraCut FBS II				
Recommended loads ¹⁾³⁾ for a single anchor or a fixing point ⁴⁾⁵⁾⁶⁾ in solid brick masonry.				
Type			FBS II 8	FBS II 10
Anchorage depth	h_{nom}	[mm]	65	85
Recommended loads (F_{rec}) in the respective base material ²⁾³⁾				
Solid clay brick (EN771-1) $\geq 240 \times 113 \times 115$ mm	$f_b \geq 12$	[kN]	1.1 ¹⁰⁾	1.4 ¹⁰⁾
Solid clay brick (EN771-1) $\geq 240 \times 113 \times 115$ mm	$f_b \geq 20$	[kN]	1.6 ⁷⁾¹⁰⁾	1.6 ⁷⁾¹⁰⁾
Solid sand-lime brick (EN771-2) $\geq 240 \times 71 \times 115$ mm	$f_b \geq 12$	[kN]	1.2 ⁷⁾¹⁰⁾	1.2 ⁷⁾¹⁰⁾
Aerated concrete (EN771-4) $\geq 499 \times 249 \times 120$ mm	$f_b \geq 6$	[kN]	0.7	0.9
Minimum spacing (s_{min}) and edge distances (c_{min})				
Minimum spacing within anchor groups of 2 or 4 anchors	s_{min}	[mm]	80	80
Minimum spacing between single anchors or anchor groups	s_{min}	[mm]	80	80
Minimum distance to the horizontal joint	$c_{min,v}$ ⁸⁾	[mm]	20	20
Minimum distance to the vertical joint	$c_{min,h}$ ⁸⁾	[mm]	40	40
Minimum distance to the free edge	$c_{min, free edge}$ ⁸⁾	[mm]	200	200
Tightening torque ⁹⁾ ($T_{tighten}$) in respective base material				
Solid clay brick ¹⁰⁾	$T_{tighten}$	[Nm]	10	10
Solid sandlime brick ¹⁰⁾	$T_{tighten}$	[Nm]	15	15
Aerated concrete	$T_{tighten}$	[Nm]	5	5

¹⁾ An appropriate safety factor is considered.

²⁾ The given loads apply to the given brick measures for masonry with superimposed load. Larger brick formats are at least equivalent in case of the loads. Base material f_b in [N/mm²].

³⁾ The loads only apply to multiple fixings of non-load-bearing systems and are valid for tensile load, shear load and oblique load under any angle.

⁴⁾ To confirm the given technical data, it is recommended to carry out tests on the construction site. In case of not visible joints a 100% testing of the anchors is recommended as the concrete screws only work in the brick but not in mortar joints.

⁵⁾ A fixing point can be a single anchor, 2 anchors or 4 anchors with a minimum spacing s_{min} . Anchor groups of 4 anchors are arranged in rectangular disposition.

⁶⁾ The fixing points have to be arranged in this way that there will be always maximum one fixing point arranged in one brick.

⁷⁾ Brick pull-out is decisive.

⁸⁾ The values $c_{min,v}$ and $c_{min,h}$ are only valid if the mortar joints are filled proper. Otherwise the joints has to be considered as free edges and $c_{min, free edge}$ is decisive. Minimum mortar strength is M 2.5.

⁹⁾ The screw is screwed in with a cordless screwdriver, an impact screwdriver or by hand. The screwing process must be finished immediately when the screw head is in contact with the assembled object. The specified tightening torque must then be applied with a torque wrench.

¹⁰⁾ The values are valid for unperforated solid bricks.

Concrete screw UltraCut FBS II for temporary fastening

Permissible loads of a single anchor¹⁾ in normal concrete of strength class C20/25 to C50/60.

For the design the complete current assessment Z-21.8-2049 has to be considered.

Type	Material/ surface	Screw-in depth h_{nom} [mm]	Minimum member thickness h_{min} [mm]	Maximum installation torque $T_{imp, max}$ ²⁾ [Nm]	Minimum spacing (s_{min}) and edge distances (c_{min})		Cracked and non-cracked concrete			
					s_{min} [mm]	c_{min} ³⁾ [mm]	Permissible load F_{perm} ⁴⁾			
							$f_{c, cube} \geq 10$ N/mm ² [kN]	$f_{c, cube} \geq 15$ N/mm ² [kN]	$f_{c, cube} \geq 20$ N/mm ² [kN]	$f_{c, cube} \geq 25$ N/mm ² [kN]
FBS II 8	gvz	50	100	400	200	65	1.9	2.3	2.6	2.9
	gvz	65	150	400	300	100	3.6	4.4	5.1	5.6
FBS II 10	gvz	55	105	400	210	70	2.2	2.7	3.1	3.5
	gvz	65	130	400	260	85	2.9	3.5	4.1	4.5
	gvz	85	205	650	410	135	5.8	7.1	8.1	9.1
FBS II 12	gvz	60	120	400	240	80	2.8	3.4	3.9	4.4
	gvz	75	150	400	300	100	4.0	4.9	5.6	6.1
	gvz	100	240	650	480	160	7.6	9.3	10.8	12.0
FBS II 14	gvz	65	115	400	230	75	2.3	2.8	3.2	3.6
	gvz	85	150	400	300	100	3.6	4.4	5.0	5.6
	gvz	115	255	650	510	170	8.9	10.9	12.6	14.0

¹⁾ Material safety factor as well as a partial safety factor for load actions of $\gamma_L = 1.4$ is considered. The screw may be used in the concrete member before the characteristic compressive strength $f_{c, cube}$ is reached. In this case, the concrete compressive strength $f_{c, cube}$ must have reached a value of at least 10 N/mm². Only intended for temporary use and one-time screwing into the same drill hole. Conditions for reuse of the screw see, approval.

²⁾ Values for impulse wrenches with tangential impact and automatic stop device.

³⁾ In case of combined action of shear load and installation close to the edge, the edge distance must be $\geq c_{min} \times 1.5$. Detail see approval.

⁴⁾ Values valid for all load directions.

Loads

Concrete screw UltraCut FBS II 6

Permissible loads for a single anchor¹⁾ for multiple use of redundant non-structural applications* in normal concrete C20/25.
For the design the complete current assessment ETA - 18/0242 has to be considered.

Type	Material/ surface	Screw-in depth h_{nom} [mm]	Minimum member thickness h_{min} [mm]	Maximum installation torque $T_{inst,max}^{2)}$ [Nm]	Cracked concrete				Non-cracked concrete			
					Permissible tension ($N_{perm}^{3)}$) and shear loads (V_{perm}^{3}); minimum spacing (s_{min}^{3}) and edge distances (c_{min}^{3}) with reduced loads				Permissible tension (N_{perm}^{3}) and shear loads (V_{perm}^{3}); minimum spacing (s_{min}^{3}) and edge distances (c_{min}^{3}) with reduced loads			
					N_{perm}^{3} [kN]	V_{perm}^{3} [kN]	s_{min}^{3} [mm]	c_{min}^{3} [mm]	N_{perm}^{3} [kN]	V_{perm}^{3} [kN]	s_{min}^{3} [mm]	c_{min}^{3} [mm]
FBS II 6	gvz	25	80	≤ 5	0.7	1.8	35	35	1.4	2.3	35	35
	gvz	30	80	≤ 5	1.2	2.3	35	35	2.4	2.3	35	35
	gvz	35	80	≤ 5	1.7	4.3	35	35	3.1	4.3	35	35
	gvz	40	80	≤ 10	2.4	4.3	35	35	3.8	4.3	35	35
	gvz	45	90	≤ 10	2.9	4.3	35	35	4.8	4.3	35	35
	gvz	50	90	≤ 10	3.6	4.3	35	35	5.7	4.3	35	35
	gvz	55	100	≤ 10	4.0	6.3	35	35	6.4	6.3	35	35

* In addition to the load table above, the following must be considered for multiple fastening of non-structural redundant systems:

A multiple fixing (redundant system) according to EN 1992-4 and CEN/TR 17079 is defined by

- at least 3 fixing points (per attached element) with at least one anchor at each fixing point and a permissible load per fixing point of 1.4 kN

- or by at least 4 fixing points with at least one anchor each fixing point and a permissible load per fixing point of 2.1 kN

- Additionally, it has to be proven that the stiffness of the attached element shall be large enough to ensure that in case of excessive slip or failure of a fastener the load on this fastener or fixing point can be transferred to neighbouring fixing points without significantly violating the requirements on the attached element in the serviceability and ultimate limit state.

For further details see EN 1992-4 section 7.3 and CEN/TR 17079.

¹⁾ Design according to EN 1992-4:2018 (for static resp. quasi-static loads). The partial safety factors for material resistance as regulated in the ETA as well as a partial safety factor for load actions of $\gamma_L = 1.4$ are considered.

²⁾ Further technical information for installation see ETA.

³⁾ In the case of combinations of tensile and shear loads, bending moments with reduced or minimal edge and axial spacings (anchor groups), the design must be carried out in accordance with the provisions of the complete ETA and the provisions of the EN 1992-4:2018.

Concrete screw UltraCut FBS II 6

Permissible loads for a single anchor¹⁾ for multiple use of redundant non-structural applications* in pre-stressed hollow-core concrete slabs of concrete strength C30/37.
For the design the complete current assessment ETA - 18/0242 has to be considered.

Type	Screw-in depth	h_{nom}	FBS II 6 gvz						
			25	30	35	40	45	50	55
Permissible load $F_{perm}^{3)}$ in the respective bottom flange thickness									
$d_b \geq 25$ mm		[kN]	0.2	0.5	0.5	0.5	0.5	0.5	0.5
$d_b \geq 30$ mm		[kN]	1.7	1.7	1.7	1.7	1.7	1.7	1.7
$d_b \geq 35$ mm		[kN]	1.7	1.9	2.1	2.4	2.6	2.9	3.1
$d_b \geq 40$ mm		[kN]	1.7	2.3	2.6	2.9	3.3	3.6	3.8
$d_b \geq 50$ mm		[kN]	1.7	2.3	3.3	3.8	4.3	4.3	5.7
Installation torque	$T_{inst,max}$	[Nm]	5.0	5.0	10	10	10	10	10
Minimum spacing	$s_{1,s2}^{2)}$	[mm]	100	100	100	100	100	100	100
Minimum edge distance	$c_{1,c2}^{2)}$	[mm]	100	100	100	100	100	100	100

* In addition to the load table above, the following must be considered for multiple fastening of non-structural redundant systems:

A multiple fixing (redundant system) according to EN 1992-4 and CEN/TR 17079 is defined by

- at least 3 fixing points (per attached element) with at least one anchor at each fixing point and a permissible load per fixing point of 1.4 kN

- or by at least 4 fixing points with at least one anchor each fixing point and a permissible load per fixing point of 2.1 kN

- Additionally, it has to be proven that the stiffness of the attached element shall be large enough to ensure that in case of excessive slip or failure of a fastener the load on this fastener or fixing point can be transferred to neighbouring fixing points without significantly violating the requirements on the attached element in the serviceability and ultimate limit state.

For further details see EN 1992-4 section 7.3 and CEN/TR 17079.

¹⁾ Design according to EN 1992-4:2018 (for static resp. quasi-static loads). The partial safety factors for material resistance as regulated in the ETA as well as a partial safety factor for load actions of $\gamma_L = 1.4$ are considered.

²⁾ Further technical information for installation see ETA.

³⁾ Valid for tensile load, shear load and oblique load under any angle. In the case of combinations of tensile, shear loads and bending moments, the design must be carried out in accordance with the provisions of the complete ETA and the provisions of the EN 1992-4:2018.

Dealer:

www.fischer-international.com



fischer stands for

Fixing Systems
Automotive
fischertechnik
Consulting
LNT Automation

fischerwerke GmbH & Co. KG
Klaus-Fischer-Straße 1 · 72178 Waldachtal
Germany
T +49 7443 12 - 0
www.fischer-international.com · info@fischer.de
