

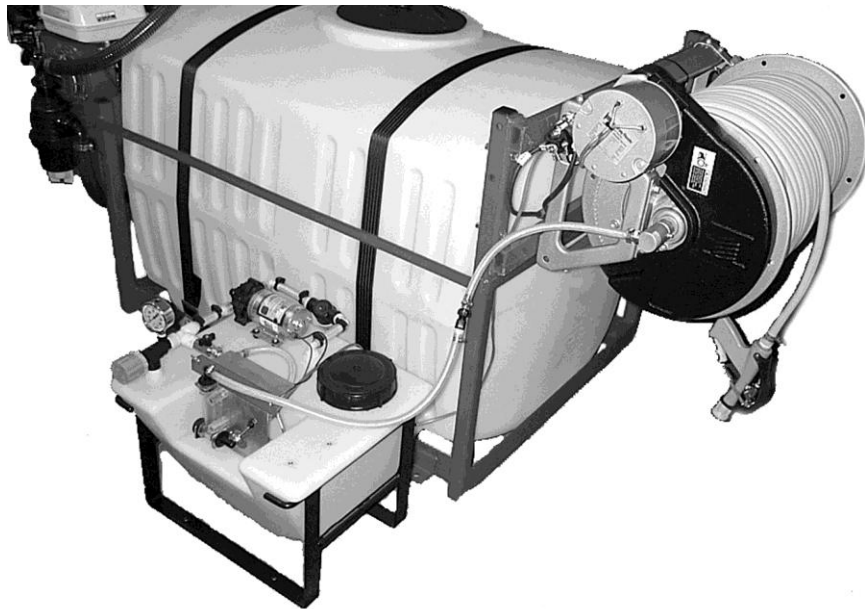

Eco-505 Spray Injection System

Operator's Manual



The Eco-505 Injection System is an add-on accessory for a turf spraying system that injects pesticide into the fertilizer stream on demand. The dual trigger spray gun and coaxial hose provide a means of minimizing unnecessary application and eliminating the need for spot spraying in a secondary operation.

Do not hesitate to call your dealer or Gregson-Clark directly with any questions or concerns. We also welcome your comments and suggestions on how we can continue to improve this product.

Toll free: 800 . 706 . 9530
Phone: 585 . 538 . 9570

Fax: 585 . 538 . 9577
E-mail: Sales@GregsonClark.com

TABLE OF CONTENTS

Safety precautions.....	2
Overview.....	3
Set-Up and Assembly.....	4
Calibration.....	6
Troubleshooting.....	8
Spare Parts lists.....	10
Spray Gun Diagram.....	11
Warranty.....	13

SAFETY PRECAUTIONS

Pesticides can cause personal injury and harm the environment when used improperly. Be sure to follow label recommendations concerning safety and disposal. Observe all safety precautions including wearing protective clothing and equipment.

- Calibrate and test using only water.
- Check with each use for leaks or damage.
- Always read and follow the label instructions of the products used.
- Do not exceed pressure of 90 psi on the primary (fertilizer) pumping system.
- Do not exceed 90 psi working pressure on the Eco-505 pump system.

OVERVIEW

The Eco-505 is an accessory device for a primary turf sprayer designed to make spot applications of pesticide while blanket applying a fertilizer solution on turf areas. The primary sprayer typically contains the material (fertilizer) to be blanket applied to the turf. The Eco-505 contains the material (pesticide) to be spot-applied on demand.

The main components of the Eco-505 are the nine-gallon tank and pumping unit, dual line hose reel, coaxial or dual line hose, and dual trigger gun. The fertilizer solution from the primary system is pumped into the right swivel connection of the dual line reel. The pesticide solution is pumped from the Eco-505 into the left swivel connection. Through a special hose connection assembly at the reel, the pesticide travels through the inner tube of the coaxial hose to the injection valve on the dual trigger gun. The fertilizer solution flows through the area around the inner tube, inside the main hose. Both solutions are pumped separately to the dual trigger gun.



Pulling the primary trigger of the dual trigger gun causes the fertilizer solution to spray out of the discharge nozzle. The Eco-505 injects pesticide solution into the flow of fertilizer at the gun, just before the nozzle, by pulling the injection trigger on the gun while holding down the primary trigger.

The recommended injection rate of flow is five ounces per minute; therefore, the injection system relies on the flow of fertilizer to provide an acceptable spray pattern at a typical fertilizer application rate of 2-3 gallons per minute.

The pesticide typically is diluted with water depending on the desired application rate. The 12-volt pump provides return agitation to the tank; however materials that require excessive agitation may not work well in the system.

SET-UP AND ASSEMBLY

Check for apparent signs of shipping damage and that the order is complete. Freight damage and shortage claims must be within five days of delivery.

Determine where to mount the tank and pumping unit on the truck. Locate it in a secure location where it is visible and easily accessible. Check under the bed for interference issues and bolt the metal frame that holds the tank to the truck bed.

If the Eco-505 is part of a new Gregson-Clark Sprayer, the reel may have been removed for shipping purposes. Re-mount the hose reel, connect the hoses to the reel, and connect the power supply to the pump from the reel solenoid.

If the Eco-505 is to be installed on an existing sprayer, remove the existing reel and replace it with the one provided. Make note of the wiring connections to ensure the new reel is re-wired correctly. Refer to the electrical wiring diagram for a typical system.

Connect the hose from the existing pumping system (fertilizer) to the 1/2" hose barb on the left-hand swivel of the reel. Connect the hose from the injection system (pesticide) to the 3/8" hose barb on the right-hand swivel of the hose reel.



WIRING DIAGRAM

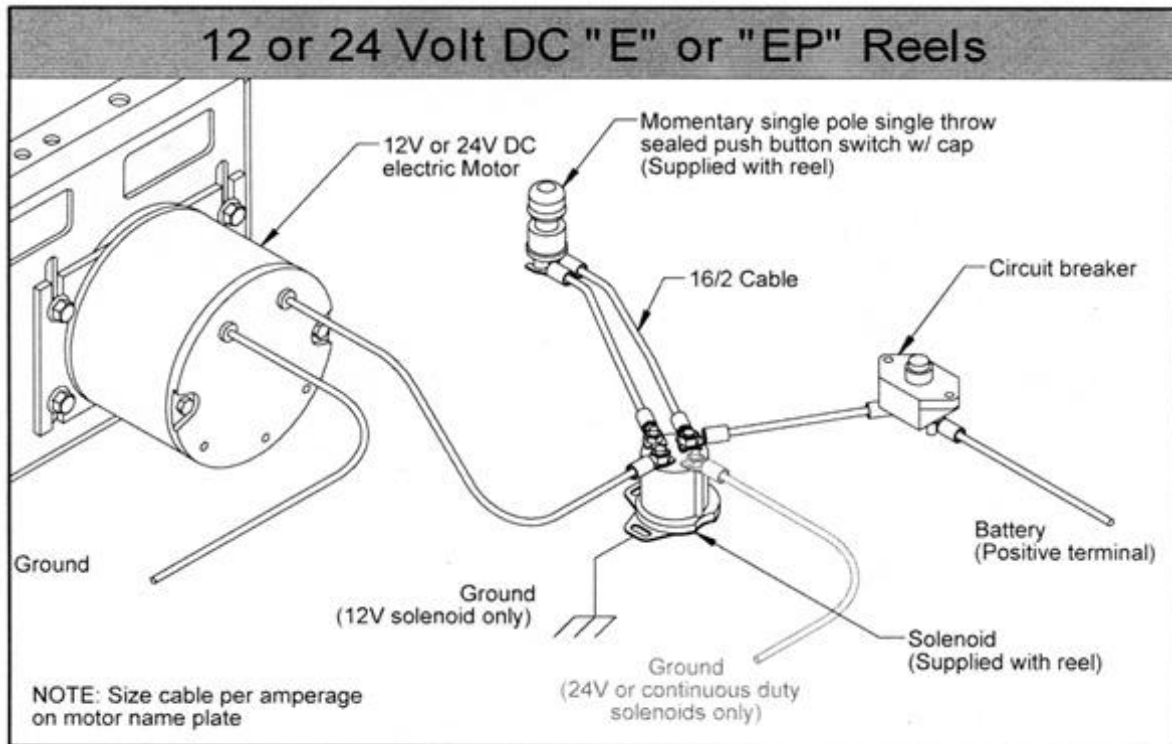

CALIBRATION

Perform a preliminary test of the Injection System with clean water and adjust the flow rate to five ounces per minute. (See Figure 1) The initial testing and calibration is done with clean water to prevent accidental spillage and waste should there be a leak. The actual chemical solution may be more viscous than water and require more pressure to achieve a flow rate of five ounces per minute.

As mentioned earlier, do not exceed 50 psi working pressure on the Eco-505 pump system. If five ounces per minute cannot be achieved at 50 psi or below, the pesticide solution may be too viscous or there may be damage to the inner tube that carries the pesticide solution.

The primary factor affecting the application rate of pesticide will be the dilution rate of the material in the injection tank. In order to calculate the dilution rate, first determine the operator's normal application rate in square feet per minute. For normal turf spraying a typical rate is about 1,000 square feet per minute. However the walking speed and effective spray width varies between individuals so it is necessary to confirm the rate.

To determine the operator's application rate:

1. Measure an area of at least 10,000 square feet.
2. Spray the measured area with water at normal walking speed and spray width between passes.
3. Record how long it takes the operator to spray the measured area.
4. Divide the area sprayed by the elapsed time.

Example: $\frac{10,000 \text{ square feet}}{9.5 \text{ minutes}} = 1,053 \text{ square feet/minute}$

Next, determine the desired application rate of pesticide, following the label recommendations. For example, 1.2 ounces per 1000 square feet

Finally, calculate the mixing ratio using these three factors:

1. The injection system adjusted to deliver 5 ounces/minute.
2. The operator's normal application rate of 1,053 square feet/minute.
3. The desired pesticide application rate of 1.2 ounces/1000 square feet.

Use the following formula to determine how much of those five ounces is water and how much is pesticide.

Operator's Application Rate x Desired Pesticide Rate = Required Pesticide Rate/Minute

$$\frac{\text{Square Feet Applied}}{1\text{-Minute}} \times \frac{\text{Ounces}}{1,000 \text{ square feet}} = \frac{\text{ounces}}{\text{minute}}$$

Example:

$$\frac{1,053 \text{ square feet}}{1\text{-minute}} \times \frac{1.2 \text{ Ounces}}{1,000 \text{ square feet}} = \frac{1.26 \text{ ounces}}{1\text{-minute}}$$

Therefore, of those five ounces delivered per minute, 1.26 ounces will be pesticide and the remaining 3.74 ounces will be water. Maintain this ratio when mixing the solution.

Example: 1.26 gallons of pesticide and 3.74 gallons of water will yield 5 gallons of solution.

Check the flow rate with a mixed solution in the injection tank. A solution that is heavier than water will require more pressure to achieve a flow rate of five ounces per minute. Adjust the pressure to maintain that rate while the injection trigger is on. The orange ball in the flow meter should rise to near the fourth step while the trigger is pulled. (See figure 1)

The flow meter is slow to respond to pressure changes. Wait 10-15 seconds while the trigger is depressed to get an accurate reading. Observe and record the pressure gauge and flow meter readings. These readings should remain constant as long as this solution is used.

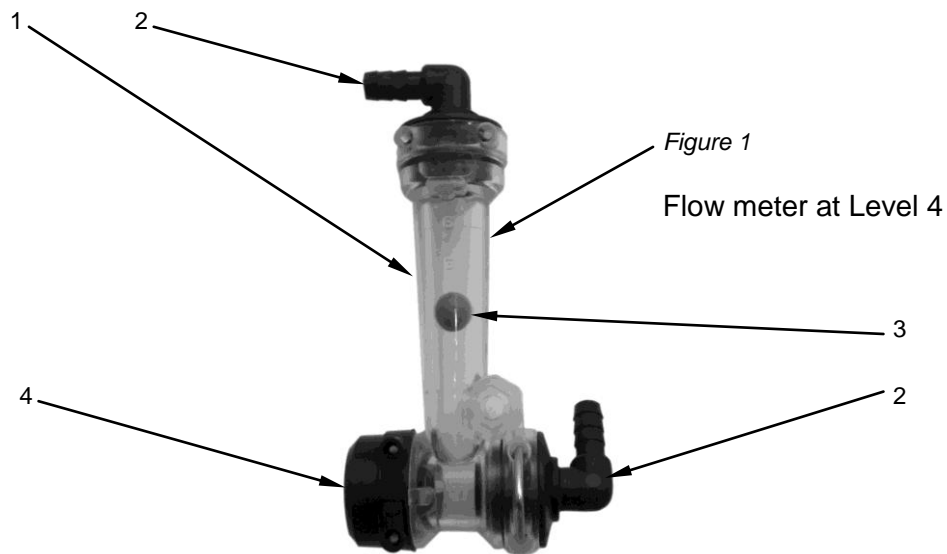

REF. #	QUANTITY	PART #	DESCRIPTION
		20460-ECO	Flow Monitor Assembly
1	1	20470-00	Flow Monitor Body
2	2	20511-00	3/8" Elbow Barb
3	1	20460-13	Orange Ball
4	1	20521	Cap

TROUBLESHOOTING

Problem	Possible cause	Solution
Pump does not run	Open electrical circuit	Check truck's battery charge Check for power to the pump Check ground to frame Check for open circuit breaker
	Defective pump	Replace as necessary
Pump runs slowly	Low voltage to pump	Check truck's battery charge
Low pressure and low flow	Pump has lost prime	Re-prime the pump by backing the Pressure Regulator all the way out
	Inadequate flow of liquid to the pump	Check liquid level in tank Clean strainer Tighten strainer bowl Check bowl gasket Check pressure gauge reading Ensure the shut-off valve is open
	Plugged pressure regulator	Disassemble and clean
	Debris in pump	Repair as necessary
	Check valve stuck open	Repair as necessary
	Solution in tank too viscous	Dilute if necessary or change materials
	Defective pump	Repair as necessary
Pressure adequate but low flow	Restriction in spray gun	Inspect and clean as required
	Restriction in hose reel	Disconnect and flush hose

Table 1

SPARE PARTS LISTS

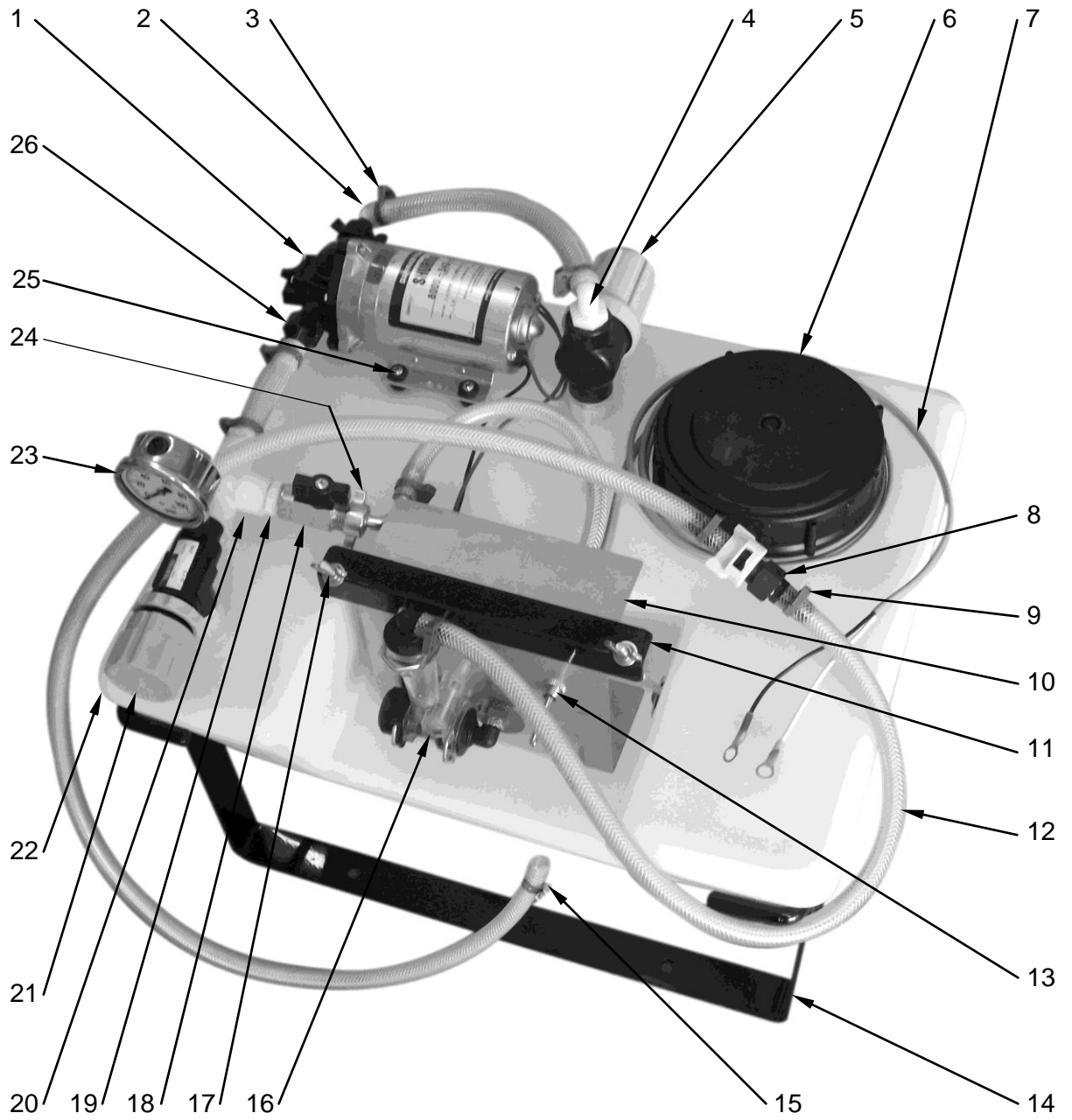

REF. #	QUANTITY	PART #	DESCRIPTION
1	1	8000-543-138	Shurflo Pump 1.83 GPM, 100 PSI
2	1	234-3926	Barb Elbow Swivel 1/2" FPT x 1/2"
3	4	5P050	Easy Seal Clamp For 1/2" ID Hose
3 (not shown)	1	6J	Clamp (Inside Tank)
4	1	EL1212	Barb Elbow 1/2" MPT x 1/2"
4 (not shown)	2	A12	Barb Straight 1/2" MPT x 1/2" (Inside Tank)
5	1	AA122-1/2-PP50	Strainer 1/2" 50 Mesh (Complete Assembly)
not shown	1	CP45102-3-SSPP	Strainer Screen 50 Mesh
not shown	1	CP23173 EPR	Strainer Bowl Gasket
6	1	3542010	Tank Lid Female 6" With Vent
7	1	ECWA1	Wire to the Battery Connection
8	1	EC1152	Check Valve Assembly (Complete)
not shown	1	11750-5	Check Valve Cartridge (Internal)
9	3	5P038	Easy Seal Clamp For 3/8" ID Hose
10	1	EC1116	Meter Mounting Bracket
11	1	SMAB1	Mounting Bracket Angle
12	1	CB38	Hose to the Left Reel Swivel Connection
13	1	7200030	Toggle Switch
14	1	4J	Clamp
15	1	SM-TS	Mounting Stand
16	1	20460-ECO	Flow Monitor
17	2	70910	Wing Nut 1/4-20
not shown	2	42216	Eye Bolt 1/4-20 x 5"
not shown	2	1171215	Fender Washer
not shown	2	1172586	Pan Head Screw
18	1	MVT12FM	Ball Valve 1/2" F x M
19	3	M12	Close Nipple Hex 1/2"
20	1	TT12	Tee Female 1/2"
21	1	23120-1/2-PP	Pressure Regulator
22	1	GCT09SM	Poly Tank, 9 Gallon
23	1	2141GXB100	Pressure Gauge 0-100 SS Liquid Filled
24	1	163.604.4	Wing Nut Barb 1/2" Steel
25	4	72566	Machine Screw #10-32 x 1" SS
26	1	234-2926	Barb Straight Swivel 1/2" FPT x 1/2"
not shown	1	CB12	Hose 1/2" ID x 15" (Inside Tank, Suction Line)
not shown	1	CB12	Hose 1/2" ID x 16" (Inside Tank, Return Line)

Spray Gun Assembly - Coax

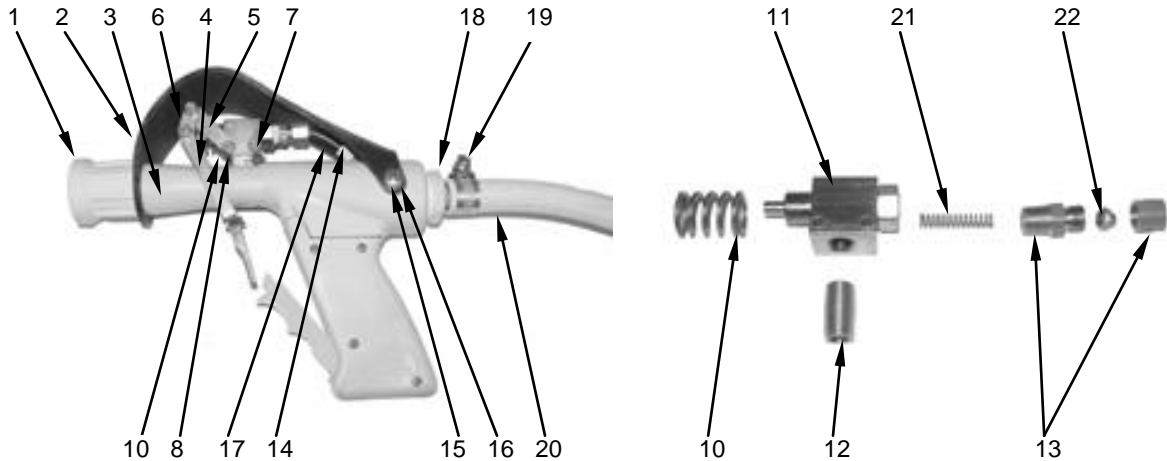

Ref. #	Quantity	Part #	Description
1	0	Blue	Nozzle 1.5 GPM
1	1	Yellow	Nozzle 2.0 GPM
1	0	Green	Nozzle 3.0 GPM
1	0	White	Nozzle 4.0 GPM
2	1	EC1142	Gun Cover Eco-505
3	1	EC1150	Gun Eco-505 - Machined
4	1	EC1143-A	Trigger Yoke
5	2	EC1144	Actuator Link
6	2	72392	Screw Machine 6-32 x 1
7	2	72390	Screw Machine 6-32 x 1
8	6	1170855	Nut Nylock #6
9	4	76058	Washer Nylon #6
* 10	1	LC-049H03S	Spring Trigger Return
* 11	1	MJV-2-ENP-V	Valve
* 12	1	112A	Nipple 1/8"
* 13	1	68-3A	Connector 3/16" Tube x 1/8" Npt
14	1	68-3A-DT	Connector 3/16" Tube x 1/8" Npt - Drilled Thru
15	2	72945	Screw S/M #12 x 1/2"
16	2	1171009	Washer Flat #10
17	0	N12-3/16 X 320	Tubing 3/16" Od x 300' Replacement Coil
17	0	N12-3/16 X 420	Tubing 3/16" Od x 400' Replacement Coil
18	1	A3412	Adapter 3/4" Npt x 1/2" Barb Nylon
19	1	6J	Clamp
20	0	COAX-300	Coaxial Hose x 300'
20	0	COAX-400	Coaxial Hose x 400'
* 21	1	LC026BC10S	Spring Plunger Return
* 22	1	260-3	Sleeve Mushroom
Not Shown	0	007642	Kit Internal Assembly For Chemlawn Gun
Not Shown	0	MJV-2-ENP-V-KIT	Top Valve Kit (* = Included in Top Valve Kit)

Spray Gun Assembly – Dual Line

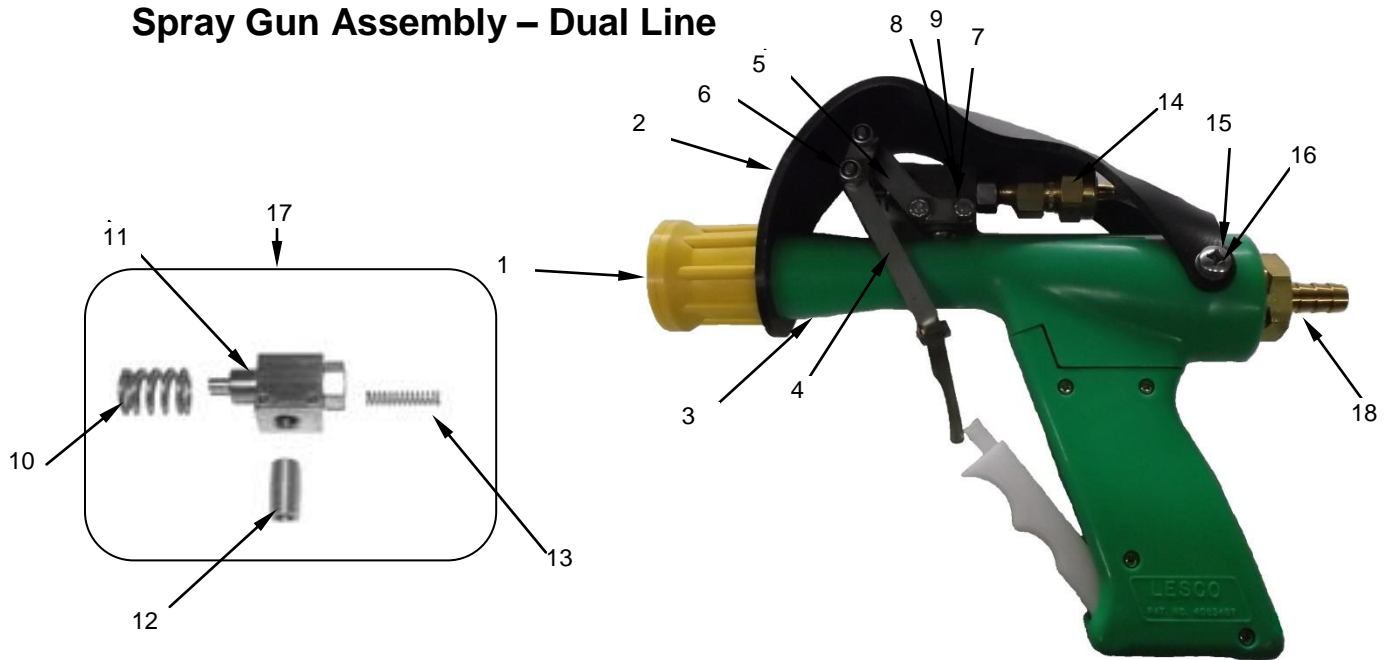

Ref. #	Quantity	Part #	Description
1	0	Blue	Nozzle 1.5 GPM
1	1	Yellow	Nozzle 2.0 GPM
1	0	Green	Nozzle 3.0 GPM
1	0	White	Nozzle 4.0 GPM
2	1	EC1142	Gun Cover Eco-505
3	1	EC1150	Gun Eco-505 - Machined
4	1	EC1143-A	Trigger Yoke
5	2	EC1144	Actuator Link
6	2	72392	Screw Machine 6-32 x 1
7	2	72390	Screw Machine 6-32 x 1
8	6	1170855	Nut Nylock #6
9	4	76058	Washer Nylon #6
* 10	1	LC-049H03S	Spring Trigger Return
* 11	1	MJV-2-ENP-V	Valve
* 12	1	112A	Nipple 1/8"
* 13	1	LC026BC10S	Spring Plunger Return
14	1	DL-Orifice-kit	Orifice body (Includes Orifice and O-ring)
15	2	72945	Screw S/M #12 x 1/2"
16	2	1171009	Washer Flat #10
17	1	MJV-2-ENP-V-KIT	Top Valve Kit (* = Included in Top Valve Kit)
18	1	125-6E	3/4 MPT x 3/8 hose barb
Not Shown	1	CP4916-20	Orifice
Not Shown	1	CP5871-BU	Orifice Gasket
Not Shown	1	007642	Rebuild Kit For Chemlawn Gun
Not Shown	0	DL0604-300	300 feet of 3/8 x 1/4 Dual Line Hose
Not Shown	0	DL0604-400	400 feet of 3/8 x 1/4 Dual Line Hose
Shown	1	157433-ECO-DL	Eco 505 Dual Line Gun

WARRANTY

The Gregson-Clark Eco-505 is warranted by the manufacturer to the original purchaser to be free from defects in materials and workmanship for a period of one year. The pump elastomers are considered normal wear items and carry a 90-day warranty against defects in materials and workmanship.

Gregson-Clark's liability shall be limited to replacement of defective components, FOB shipping point. In no event shall Gregson-Clark be liable for any special, incidental, or consequential damages including loss of profits.