

裘皮机

FUR MACHINE

使用说明

Operation Manual

零件图册

Spare Parts List

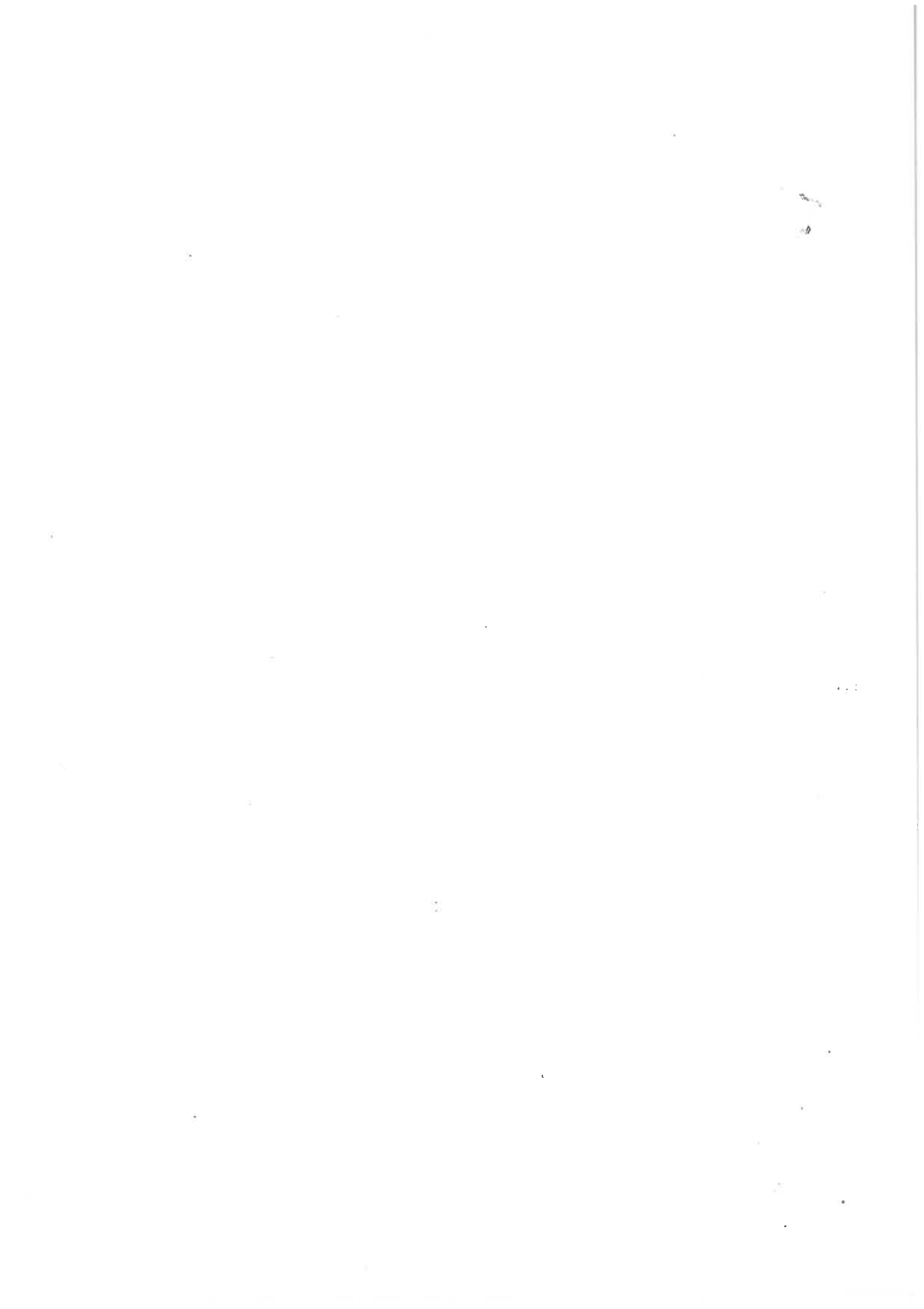

目 录

1.设备 安 装	4
2.使 用 说 明	5
3.使用故障的排除	5
4.机器的安装定位	6
5.机器故障的排除	6
6.零 件 图 样	10

LNDEX

1.INSTALLATION	7
2.SEWING PROBLEMS	8
3.OPERATING INSTRUCTIONS	8
4.SETTING OF MACHINE	9
5.MACHINE PROBLEMS	9
6.DRAWINGS	10

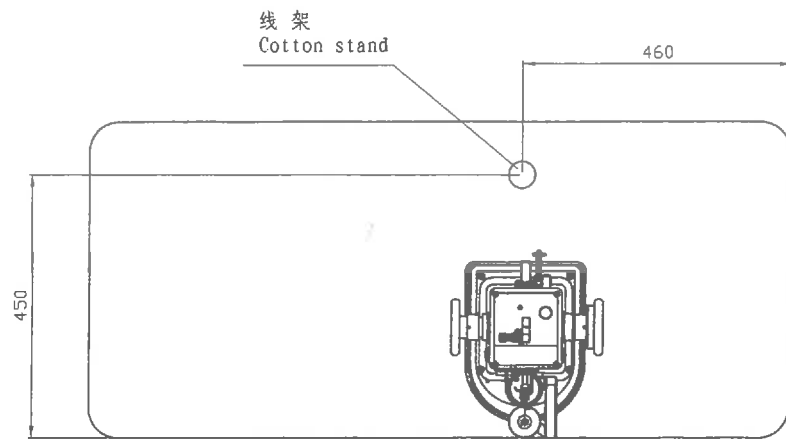

注意
台面必须水平

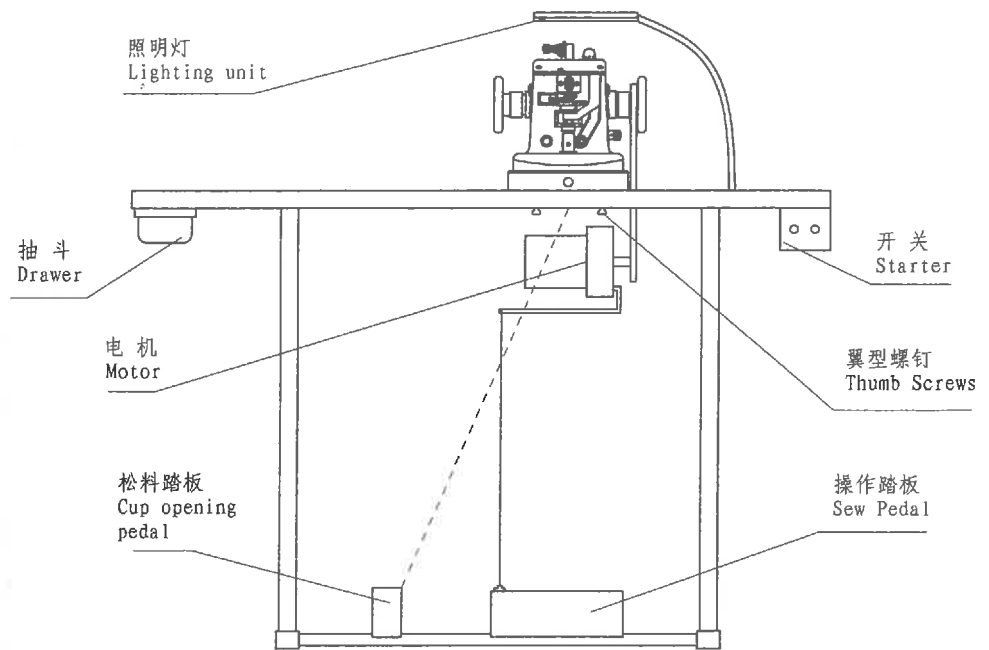

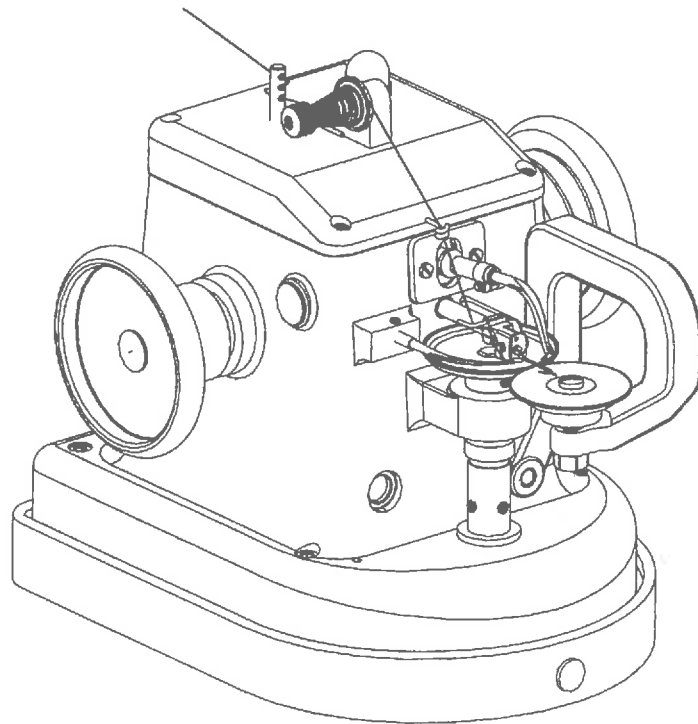
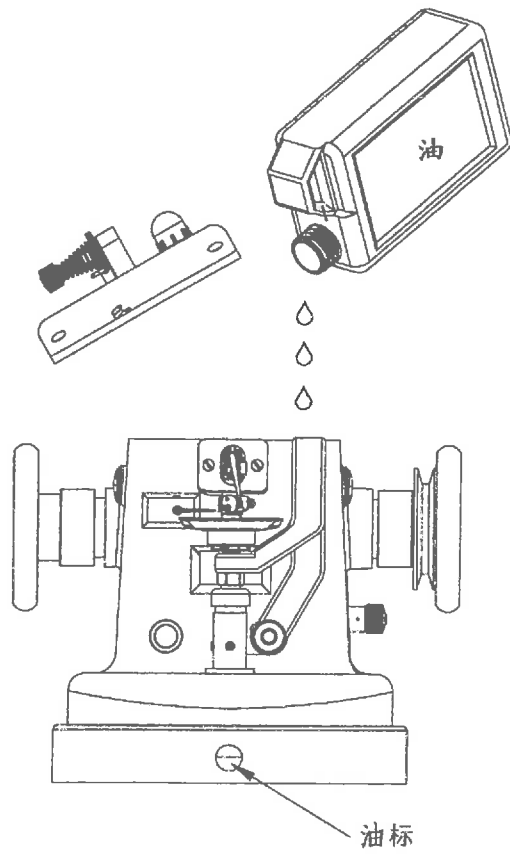

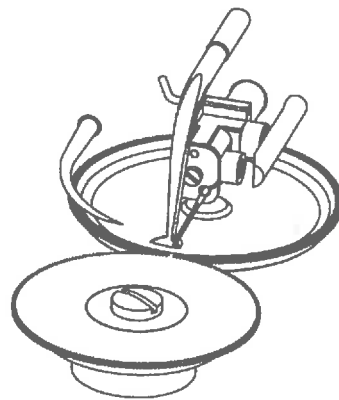
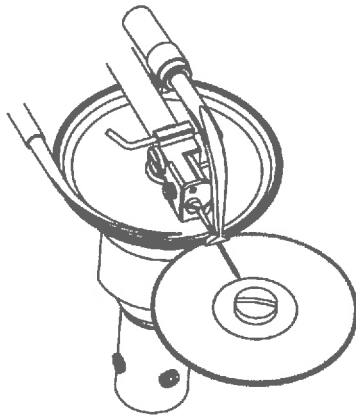
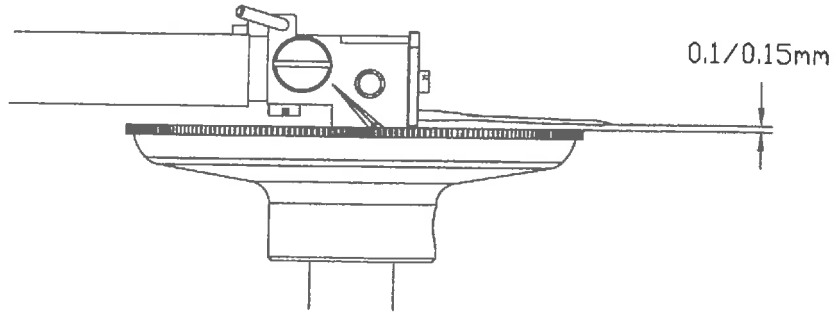
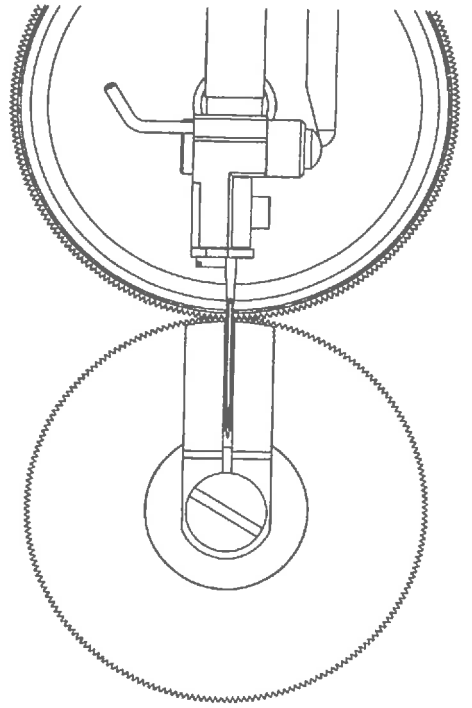
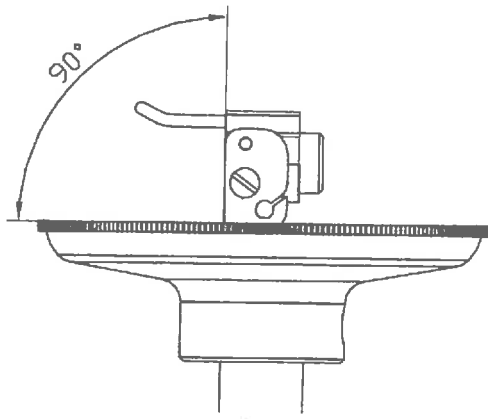

一、设备安装

注意事项：机器在操作开动前必须先充油。

参阅后图（1）

- 1.1 检查机器及所提供的附件的完整：（参见后表）
- 1.2 如果使用新机器，请按手册所提供的模样钻孔；
- 1.3 将马达、开关、踏板装到机架；
- 1.4 选择一带轮以获得所需转数；
- 1.5 将机器安置好后；将两异型螺钉从台板下穿过台面与机器固定；
- 1.6 松开顶盖螺钉并移去顶盖；按油标水平线灌油；然后；再安装好顶盖；
- 1.7 将线架安装靠近机器处的机架上；
- 1.8 用“S”钩把送料杠杆与操作踏板边连接起来；但应确保当踏板释放时，压料盘应处接触状态；
- 1.9 调节皮带皮带张力，用手在皮带跨距终检，轻轻压下时，皮带能压移 3mm；

过紧张紧力，将会对机器造成危害

- 2.10 运转机器，同事检查在油标窗口，是否有油泵泵油状况，如果没有，请参阅第五节。
- 2.11 机器的转数能达到 3000 转/分，但是我们推荐为 2600 转/分。

注：如本机属自动润滑机种，则应先将 安装到底盘底面；然后再放置到台板上进行固定。（见图 3）

附件供应一览表（各机型）

- 1 翼型螺钉及垫圈
- 1 线架组件及 2 螺钉
- 1 “S”钩
- 1 链（长 1 米）
- 1 2.5mm 六角扳手
- 1 3mm 六角扳手
- 1 4mm 六角扳手
- 1 5mm 六角扳手
- 1 V 型三角带
- 1 油漏斗
- 1 250ml 润滑油
- 1 螺丝刀
- 10 机针
- 1 贮油罐及回油管（包括螺帽、O 型圈）
- 1 镊子

二、使用说明

2.1 首先检查运输过程的损伤

2.2 针及线

459 R 用于水貂、狐等

16×231 用于合成纤维等材料

缝线推荐上光蜡线或类似涤纶化纤等线种。

推荐参考

表一

针型	机针规格	线号规格
4-4	40	120-200
4-5A	50	100-120
2610-4	70	80-120
1-1	85	60-100

2.3 穿线

装上机针并使其短槽向上，且确保推足到限位位，再按图式穿线。

2.4 维护

经常查看油罩，以确保油泵是否正常工作，如果油罩中无油，则可能是油泵滤油网堵塞，或使用了不适当的油，以及查看一下油水平线。

每年都要彻底的更换一次油，换油时，将机器从底盘上移去，将机器内的脏油吸去，清洁油泵的滤网和底盘，然后将机器重新安放在底盘上，再移去上顶盖，加入 250 升专用油。如机针或钩针弯曲损坏时，应马上更换。

二、使用故障的排除

故障	处理方法
断线	换针；
	减少张力；
	检查各过线处是否光滑；
	截短针杆压线簧
	检查钩针是否弯曲或损坏；
断针	检查机针直线度；
	缓缓转动机器，察看机针是否碰到针板或压料盘；
	检查压料盘高度；
	察看钩针是否碰到机针；
线迹长度不均	清除送料轮及送料夹块上的过量的油；
	重新更换送料夹块；
钩针过度的间隙	更换滚珠
缝料的前片送入不正常	顺时针防线调整拉簧调节螺钉，以增加张力。
线迹不良，漏针	检查钩针的间隙及同步情况；
	查看线换的形成，如不能，则试换较小号针；
	检查机针是否能刺过三角形线环；
	检查线是否能被顺利的拉过针孔；
	连续型前卫长丝，能引起线迹不良跳针

四、机器的安装定位

1. 这部分将讲如何检查及调整机器。

注意：调节任何部分之前先检查，如果确需调整，调节量也不宜过多。

4.1 参考表 选用合适的针号规格。（一般在机器出厂时已根据推荐表装上了相应的针）将针距调至最大；

4.2 检查机针是否与送料盘垂直。（见图 4）

如不垂直，则旋松驱动架转动针杆，再旋紧；

4.3 检查机针是否平行于针板，并处于针板的中间（见图 5）

如果机针并不平行于针板且不在其中间，那么将机器反置，使上顶边向下，并松开压料盘螺钉及压料盘轴螺钉使针板松动，然后，配合转动滑臂及机针，使机针处于正中并与针板槽平行。

再紧固压料盘螺钉及压料盘轴螺钉。

4.4 检查送料盘高度

送料盘与机针针孔间应有 0.1~0.15mm 的间隙。（见图 6）

如果送料盘需调节，可旋松二个紧固螺钉，移动送料盘或上或下，与符合要求后，再旋紧螺钉。

4.5 将钩针放入钩针杆内，并且定位，其放入的长度，应是党钩针经过机针上的针孔时，正好是针孔回缩一半，并处于钩针靴部长度的中间处。（见图 7）

转动带轮，使钩针向送料轮防线运动，在钩针运行到针的侧边时，钩针应刚好从针旁掠过而不应碰撞。（见图 7）。在返程中，钩针靴部后跟处应在机针下面运行，同事机针尖不应外突。

通过以上对钩针的安装，在下一阵穿过缝料前，机针将处于完好位置；来锁住线迹。

五、机器故障排除

故障	处理方法
油泵中的有打不上油罩	1. 试一下把针距调到最长时，再看运转机器时的情况；
	2. 有必要检查一下，油水平线、油量；
	3. 把机器从底盘卸下来，检查一下滤油网。
油密封漏油	在调换油封前，先试一试下列方法：
	1. 卸下飞轮及带轮
	2. 用薄纸擦干净；
	3. 在油封无沾上任何油的情况下再装上飞轮及带轮；
	4. 运转机器
	如果以上步骤不能解决漏油，再参照零件图换上新的油封。
机器停止送料或有反常状态	1. 用洁净薄油清洁送料夹块并重新就位；
	2. 重新更换送料夹块及止动夹块
机油从十字头遮护板处或针距调节长槽孔处漏油	检查油分配器中的回油管是否堵塞，
	如这样，则油将会从油分配器顶部溢出，而引起油液过量的飞溅
钩针过量松动	检查凸轮滚球，如必要时，换新球。
机器噪声	检查驱动架偏心轮间隙及钩针偏心轮间隙如必要时则更换之。

1. INSTALLATION

IMPORTANT: THE MACHINE MUST BE FILLED WITH OIL BEFORE OPERATION

Refer to the drawing opposite.

- 1.1 Check that the machine and accessories supplied are complete (see list overleaf).
- 1.2 If using a new stand, drill these according to the template provided with this handbook.
- 1.3 Attach the motor, starter, and pedals to the stand.
- 1.4 Choose a motor pulley to achieve the desired machine speed.
- 1.5 Place the machine in position and screw both thumb screws through from underneath the table top.
- 1.6 Remove the machine lid by unscrewing all four cap head screws through from underneath the table top.
- 1.7 Attach the cotton stand to the stand at the rear of the machine.
- 1.8 Connect the cup opening lever to the pedal using the chain and "S" hooks. Ensure that the cups are able to touch when the pedal is released.
- 1.9 Fit either an endless belt or the belt supplied so that the belt can be moved 3 cm under gentle hand pressure at the middle of its span

OVER TENSIONING WILL DAMAGE THE MACHINE

2.1 Run the machine and check that oil is being pumped up to the oil sight dome. If it is not, please read Section.5.

2.2 The speed of these machines can be 3000 R.P.M. Although we recommend 2600 R.P.M.

Note: If the machine is not an auto-oil type, please fix the return pipe at the bottom of the base at first, then mount the machine at the table. (see fig 3)

LIST OF ACCESSORIES SUPPLIED WITH EACH MACHINE

- | | |
|----|--|
| 1 | Machine thumb screws with washers |
| 1 | Cotton stand assembly complete with 2 screws |
| 2 | "S" Hooks |
| 1 | 1 metre length of chain |
| 1 | 2.5mm Hexagon wrench |
| 1 | 3mm Hexagon wrench |
| 1 | 4mm Hexagon wrench |
| 1 | 5mm Hexagon wrench |
| 1 | V Belt |
| 1 | Oil funnel |
| 1 | 250ml bottle oil |
| 1 | Screw driver |
| 10 | Needle |
| 1 | Oil reservoir with oil return pipe, (2 nuts, 1 "O" ring) |
| 1 | Thread nipper |

2. OPERATING INSTRUCTIONS

2.1 Initial Checks

Check for any transit damage.

2.2 Needles and Thread

459R for mink, fox, etc.

16×231 for synthetic materials

The thread recommended is either glazed cotton or terylene, although other stpes can be used.

Recommendations:

TABLE 1

MACHINE TYPE	NEEDLE SIZE (Used for timing)	THREAD SIZE
4-4	40	120 to 200
4-5A	50 Metric	100 to 150
2610-4	70 Sizes	80 to 120
1-1	85	60 to 100

2.3 Threading up

Fit the needle to the needle bar, short groove (or scarf) uppermost, and make sure it is fully back against its stop. Thread up following the diagram opposite.

2.4. Maintenance

Always check that the pump is pumping oil into the sigyht dome. If it is not, the most likely causes are either a blocked filter, or insufficient oil-check the oil level gauge.

The oil should be completely changed at YEARLY INTERVALS. To do this, remove the machine from the base, tip the dirty oil away, and clean the tray and the filter on the pump. Replace the machine on its base. Remove the machine lid and fill with 250ml oil.

If the needle or looper are bent, change them immediately

3. SEWING PROBLEMS

PROBLEM	SUGGESTED CHECK SEQUENCE
Breaking cotton	Change needle Try less tension.
	Use stronger Cotton.
	Check thread path for smoothness.
	Shorten spring in needle Plunger.
Breaking needles	Check looper is not bent or damaged
	Check needle is straight.
	Carefully turn machine over and watch.
	Needle for hitting needle plate or cups.
	Check cup heingt.
Uneven stitch length	Check looper is not hitting needle.
	Check feed timing.
Excessive looper play	Clean excess oil off feedwheel and feed gripe.
	Replace feed grips.
Front piece of material is not fed correctly	Replace cam bell.
Mis stitching	Adjust arm temsion by turning adjusting clockwise to increase tension.
	Check there is sufficient cotton temsion.
	Check looper clearances and timing of machine.
	Check that a "loop" is being made; if not try a smaller needle.
	Check needle is passing through triangle. Try lesss depth of seam.
	Check cotton is easily pulled through eye of needle.
Continuous filament thread can cause misstitching.	

4.SETTING OF MACHINE

This section allows the setting and timing of the machine to be checked and IF NECESSARY describes how to adjust the machine.

IMPORTANT: CHECK BEFORE ADJUSTING ANYTHING;IF ADJUSTMENT IS REQUIRED ONLY ADJUST BY A SMALL AMOUNT.

4.1 Fit a needle of the size you are going to sew with.The machine will have been set in the factory with the recommended needle size as in Table 2.2.Set the machine to the largest stitch.

4.2. Check Needlebar is Square to Back Cup

If this is not then slacken the carriage,twist the needlebar,and retighten the carriage.

4.3 Check Needle is Parallel and Central to Needleplate

If the needle is not parallel and central to the needleplate slacken the arm by turning the machine upside down and undo the armslide bolt.Slacken the needleplate by undoing the central screw.A combination of rotating the arm and then the needleplate must be used to bring the needle central and parallel to the groove in the needleplate. Retighten the armslide bolt and the central screw.

4.4 Check Cup heights

The back cup should have 0.1 to 0.15mm clearance from the eye of the needle.

If the back cup needs adjusting,slacken both grub screws with the allen key,move the cup up and down as required,and retighten the grub screws.

4.5 SETTING OF LOOPER

Put looper into looper carrier and set in position so that the looper when crossing over the needle plate and the eye of the needle has passed half way across the length of the shoe of the looper (see fig 8).Turning the belt wheel to turn the looper toward the back cup make sure that when the looper comes against the side of the needle that it is not striking the needle (only brushing against it).See(fig 9).Setting of looper in back stroke motion the looper heel goes under the needle. Make sure that the needle is not protruding.

BY following this looper setting,the needle will be in perfect position to lock the stitch before penetrating the material for the next stitch.

5.MACHINE PROBLEMS

PROBLEM	SUGGESTED ACTION
Oil stops being pumped to oil sight dome	(1)Try changing to maximum stitch length and run machine.
	(2)Check oil level-top up if necessary.
	(3)Check oil filter by removing machine from base.
Oil leaks from a seal	Before changing seal try the following
	(1)Remove pulley/flywheel
	(2)Clean and dry seal with tissue.
	(3)Replace pulley/flywheel without any oil on seal.
	(4)Run machine
If this procedure fails to cure leak,then replace seal with New seal-see parts list for nummber	
Machine feed stops or is erratic	(1)Clean feedgrips and feedwheel with lightly oil and replace.
	(2)Replace feedgrips and retaining frip
Oil leaks from crosshead shield or stitch length adjuster sloop	Check return pipe on oil distributor is not blocked.
	If so, then oil can oberflow over the top the top of the Distributor and cause excessive oil splash
Excessive looper play	Check cam ball.Replace if necessary.
Machine is noisy	Check play in carriage eccentric and strap eccentric.Replace if necessary

零件图册

图册目录

1. 顶盖部件	11
2. 机壳部件	13
3. 主轴部件	15
4. 针杆部件	17
5. 钩针部件	19
6. 送料部件	21
7. 压料部件	23
8. 润滑部件	25

PARTS CATALOG

DRAWINGS

1. Machine Lid Assembly	11
2. Machine Seals	13
3. Main shaft and Eccentire	15
4. Needle Bar Assembly	17
5. Frame part Components	19
6. Feed Assembly	21
7. Arms and Cups	23
8. Lubrication System and cotton stand	25

1. 顶盖部件 Machine Lid Assembly

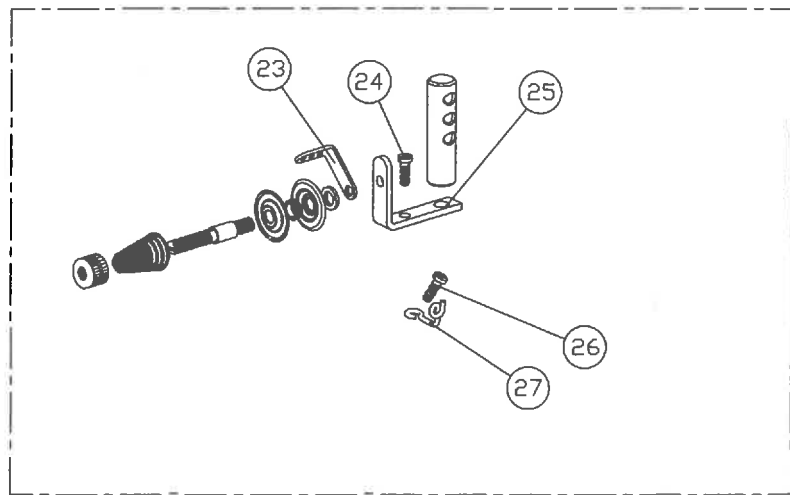
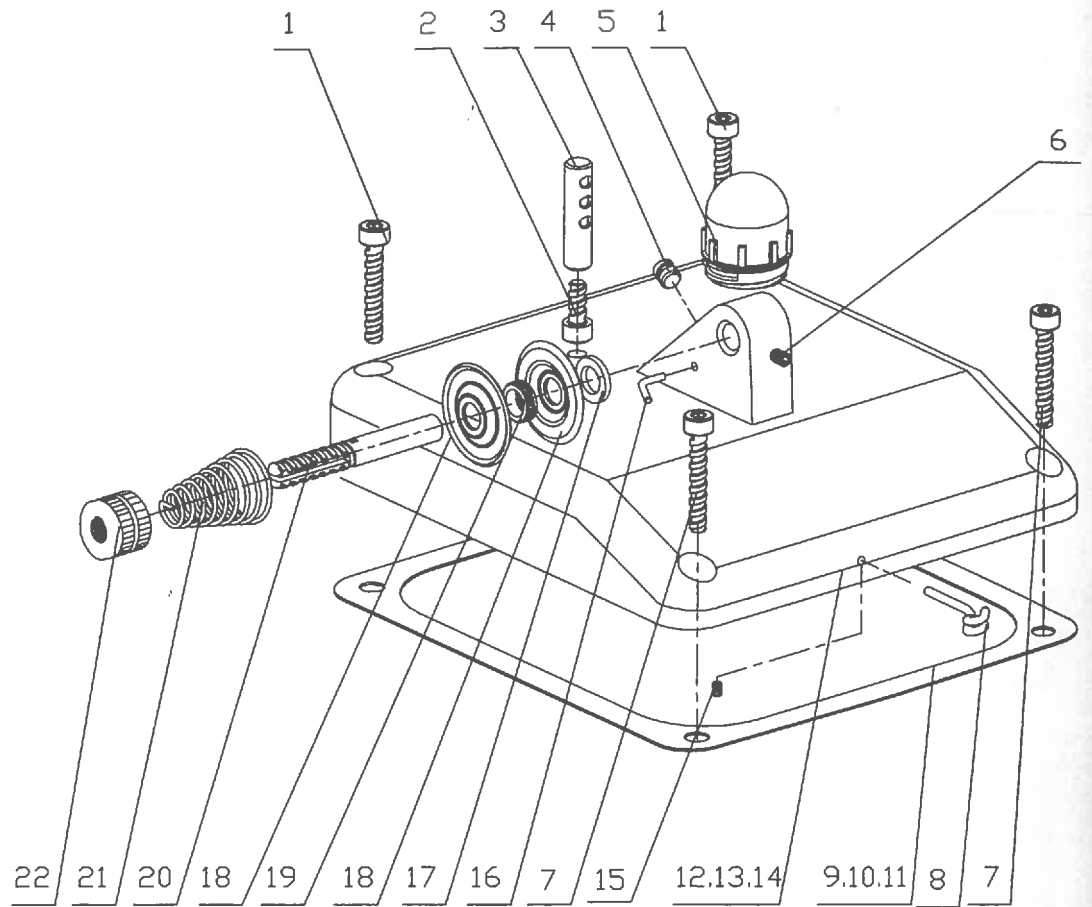

1. 顶盖部件 Machine Lid Assembly

序号	零件号	零件名称	Description	4-4	4-5	4-5A	4-6	4-6A	2610	2610	1-1
1	1-1	内六角圆柱头螺钉 M4×25	Screw M4×25					2			
2	1-2	内六角圆柱头螺钉 M4×10	Screw M4×10				1				
3	1-3	过线钉	Screw				1				
4	1-4	紧定螺钉 SM11/64×40 L6	Screw SM11/64×40 L=6				1				
5	1-5	油罩	Oil Cover				1				
6	1-6	油罩	Oil Cover				0				
7	1-7	内六角圆柱头螺钉 M4×14	Screw M4×14				2				
8	1-8	过线圈	Thread Guide Ring				1				
9	1-9	顶盖垫圈	Cover Washer			1			0		
10	1-10	顶盖垫圈	Cover Washer			0			1	0	
11	1-11	顶盖垫圈	Cover Washer				0				
12	1-12	顶盖垫圈	Cover Washer				0				1
13	1-13	过线圈紧定螺钉 SM11/64×40 L4	Screw SM11/64×40 L=4				1				
14	1-14	挡油圈	Oil Preventing rat				1				
15	1-15	顶盖	Top Cover			1					0
16	1-16	过线钩	Thread Guide Hock				1				
17	1-17	夹线板垫圈	Tension Washer		1		2				1
18	1-18	夹线板	Tension Disc				2				
19	1-19	夹线板过线圈	Tension Disc Thread Guide Ring		1		2				1
20	1-20	夹线螺钉	Cotton Tension Spring Nut		1		2				1
21	1-21	夹线簧	Cotton Tension Spring		1		2				1
22	1-22	夹线螺母	Thread Tension Nut		1		2				1
23	1-23	过线板	Thread Tension Guide		0		1				0
24	1-24	线架固定螺钉 M5×10	Screw M5×10		0		1				0
25	1-25	过线架座	Thread Guide		0		1				0
26	1-26	一字紧定螺钉 M4×8	Screw M4×8		0		1				0
27	1-27	双线过线圈	Thread Guide		0		1				0
28	1-28	顶盖 (方)	Top Cover				0				
30	1-30	顶盖	Top Cover			0			1	1	0
31	1-31	顶盖	Top Cover				0				
32	1-32	顶盖	Top Cover				0				1

2. 机壳部件 Machine Seals

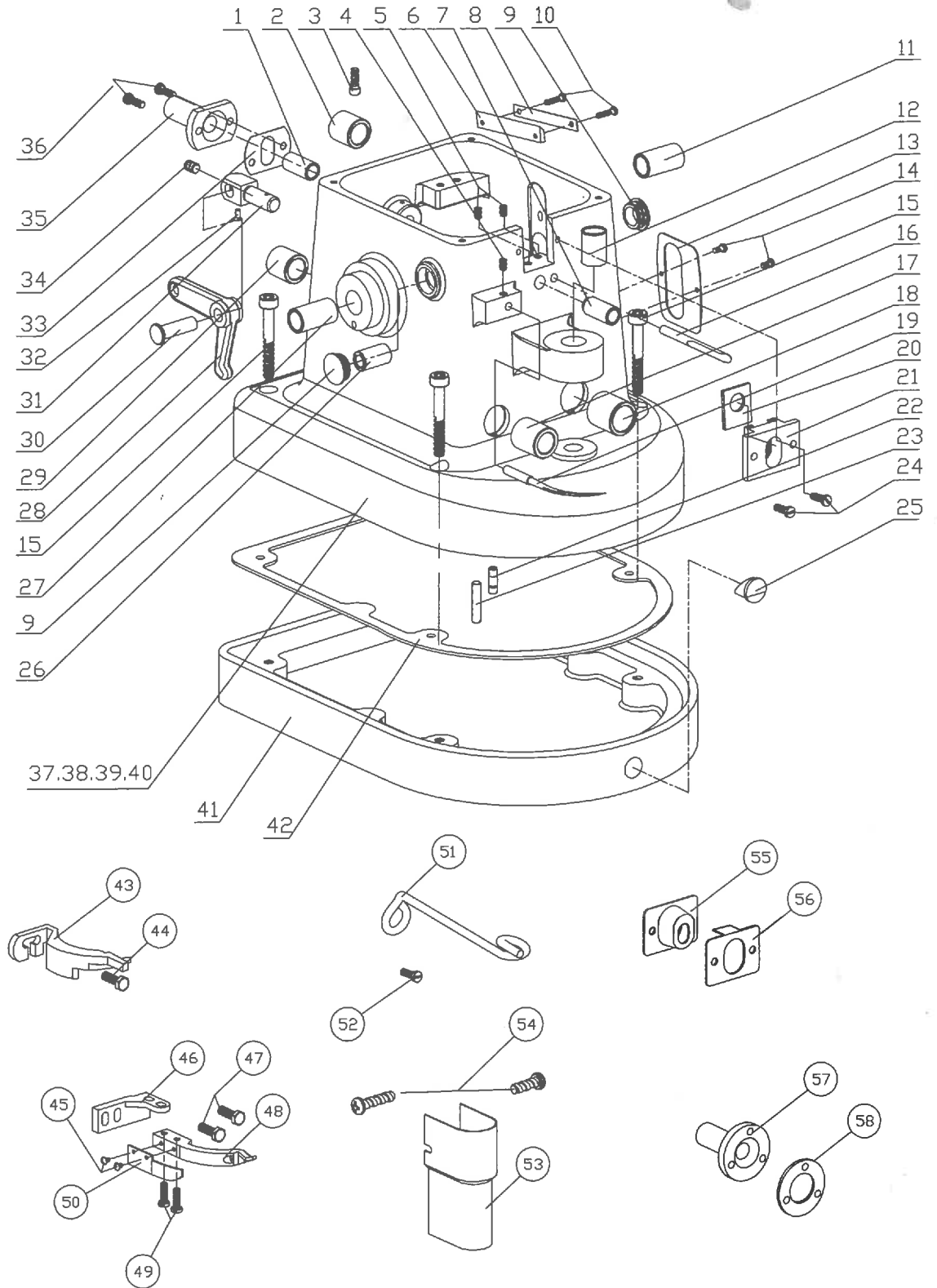

2. 机壳部件 Machine Seals

序号	零件号	零件名称	Description	4-4	4-5	4-5A	4-6	4-6A	2610	2610	1-1
1	2-1	针杆后衬套	Needle Bar Bush(Rear)					1			
2	2-2	压料杆后套	Presser bar bush					1			
3	2-3	紧定螺钉 SM11/64×40 L12	Screw SM11/64×40 L12					1			
4	2-4	挡料杆紧定螺钉 SM11/64×40 L6	Screw SM11/64×40 L6					1			
5	2-5	紧定螺钉 SM11/64×40 L6	Screw SM11/64×40 L6					2			
6	2-6	拦油板	Oil Retaining Plate					1			
7	2-7	针杆前衬套	Needle Bar Bush(Gront)					1			
8	2-8	拦油板垫片	Oil Retaining Plate Shim					1			
9	2-9	钩针杆座轴闷头	Plug					2			
10	2-10	半圆螺钉 M3×12	Screw M3×12					2			
11	2-11	主轴右轴套	Main Shaft Bush					1			
12	2-12	送料轴上衬套	Bush					1			
13	2-13	针距指示牌	Stitch length plate					1			
14	2-14	针距指示牌铆钉	Screw					2			
15	2-15	内六角圆柱头螺钉 M6×45	Screw M6×45					4			
16	2-16	松线钉	Thread Release Pin					1			
17	2-17	压料活动轴前衬套	front					1			
18	2-18	压料杆前衬套	Presser bar buch					1			
19	2-19	挡料杆	Workguide		1			0			1
20	2-20	挡油滑板	Crosshead Shield Gasket		0			1	1	0	
21	2-21	挡油滑板座	Crosshead Shield		0			1	1	0	
22	2-22	弹簧座	Spring set			1		0	0	1	
23	2-23	止动夹紧销	Clutch Pin			1		0	0	1	
24	2-24	半园头螺钉 M4×12	Screw M4×12					2			
25	2-25	油标	Oil Window					1			
26	2-26	钩针杆座轴左衬套	Needle Bar Bush					1			
27	2-27	主轴左轴套	Main Shaft Bush					1			
28	2-28	松料扳手	Cup Opening Lever					1			
29	2-29	压料杆后衬套	Presser Bar Bush					1			
30	2-30	松料扳手连接销	Cup Opening Leverling Pin					1			
31	2-31	松料扳手座	Cup Opening Lever Suppoet					1			
32	2-32	松料扳手定位销	2.5×22					1			
33	2-33	针杆油封挡圈	Needle Bar Oil Gasket					0			
34	2-34	松料扳手座螺钉 SM15/64×28 L8	Screw SM15/64×28 L8					1			
35	2-35	针杆油封	Needle Bar Oil Cap					0			
36	2-36	内六角圆柱头螺钉 M4×12	Screw M4×12					3			
37	2-37	机壳	Frame			1					0
38	2-38	机壳	Frame					0			
39	2-39	机壳	Frame				0				1
40	2-40	机壳	Frame			0		1	1	0	
41	2-41	油盘	Oil pan					1			
42	2-42	油垫	Washer					1			
43	2-43	挡料棒	Workguide		0		1			0	
44	2-44	挡料棒螺钉 M5×10	Screw M5×10		0		1			0	
45	2-45	送料盘护罩螺钉 M2.5×6	Screw M2.5×6			0		2		0	
46	2-46	挡料棒座	Guide Connector					1		0	
47	2-47	圆柱头螺钉 M6×10	Screw M6×10					2		0	
48	2-48	挡料棒	Work Guide					1		0	
49	2-49	挡料棒紧固螺钉 M4×8	Screw M4×8					2		0	
50	2-50	送料盘护罩	Guard Of Work Guide					0		0	
51	2-51	双线过线圈	Thread Tension Guard					0		0	
52	2-52	圆柱头螺钉 M5×10	Screw M5×10					1		0	
53	2-53	送料轴护罩	Feeding Shaft Cover				1				0
54	2-54	圆柱头螺钉 M4×6	Screw M4×6		0			1			0
55	2-55	挡油罩	Crosshead Shield			1			0	0	1
56	2-56	挡油板	Crosshead SHield			1			0	0	1
57	2-57	针杆油封	Needle Bar Oil Cap					1			
58	2-58	针杆油封挡圈	Needle Bar Oil Gasket					1			

3. 主轴部件 Mainshaft and Eccentire

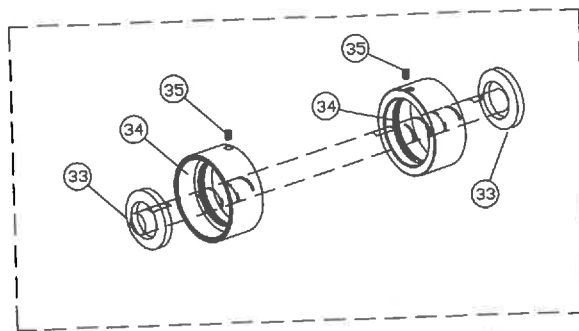
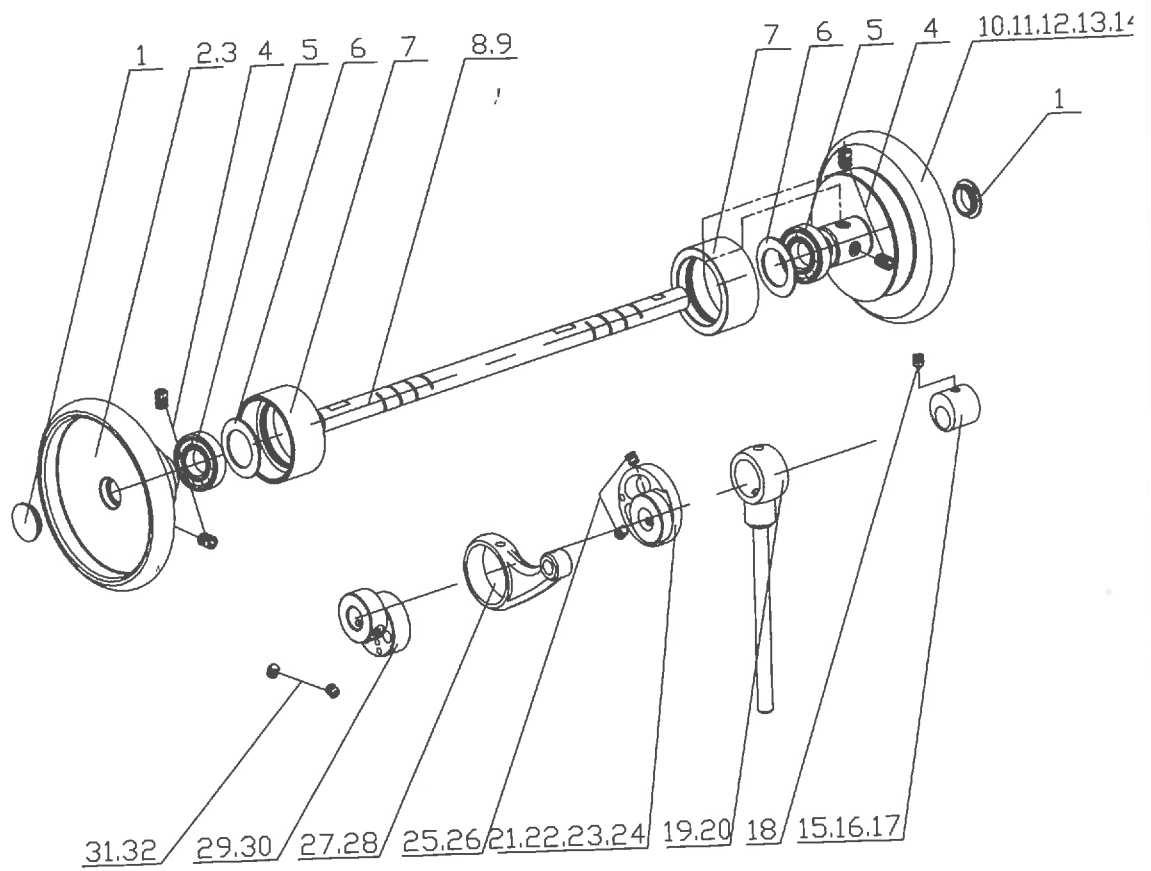

3. 主轴部件 Mainshaft and Eccentire

序号	零件号	零件名称	Description	4-4	4-5	4-5A	4-6	4-6A	2610	2610	1-1
1	3-1	主轴闷头	Plug						2		
2	3-2	手轮	Fly Wheel					1			
3	3-3	手轮	Fly Wheel					0			
4	3-4	内六角凹端紧定螺钉 M6×8	Screw M6×8					4			
5	3-5	主轴油封	Skeleton Oil Seal					2			
6	3-6	主轴垫圈	Washer					2			
7	3-7	主轴油罩	MainshaftTetaining					2			
8	3-8	主轴	Mainshaft				1				0
9	3-9	主轴	Mainshaft				0				1
10	3-10	带轮	Pulley Wheel	1		0			1	1	0
11	3-11	带轮	Pulley Wheel	0	1				0		
12	3-12	带轮	Pulley Wheel	0		1			0		
13	3-13	带轮	Pulley Wheel				0				1
14	3-14	带轮	Pulley Wheel				0				
15	3-15	送料偏心轮	Needle Bar Eccentric Cam	1		0					1
16	3-16	送料偏心轮	Needle Bar Eccentric Cam	0	1				0		
17	3-17	送料偏心轮	Needle Bar Eccentric Cam	0		1					0
18	3-18	一字锥端紧定螺钉 M5×6	Screw M5×6					1			
19	3-19	送料偏心连杆	Feed Eccentric cam Assy	1		0					1
20	3-20	送料偏心连杆	Feed Eccentric cam Assy	0		1					0
21	3-21	针杆偏心轮	Feed Eccentric	1		0					1
22	3-22	针杆偏心轮	cam Assy	0	1				0		
23	3-23	针杆偏心轮	Cam Assy	0		1					0
24	3-24	针杆偏心轮	BigEccentric				0				
25	3-25	内六角圆柱头螺钉 M5×6	Screw M5×6					0			
26	3-26	内六角平端紧定螺钉 M5×6	Screw M5×6			0					2
27	3-27	钩针偏心轮连杆	Needle Bar Eccentric cam				1				
28	3-28	钩针偏心轮连杆	Needle Bar Eccentric cam				0				
29	3-29	钩针偏心轮	Looper Eccentric cam	1		0					1
30	3-30	钩针偏心轮	Looper Eccentric cam	0		1					0
31	3-31	内六角圆柱头螺钉 M5×6	Screw M5×6					1			
32	3-32	内六角凹端紧定螺钉 M5×7	Screw M5×7					0			
33	3-33	垫圈	Washer					0			
34	3-34	棉线	Cotton thread					0			
35	3-35	一字紧定螺钉 M4×5	Screw M4×5					0			

4. 针杆部件 Needle Bar Assembly

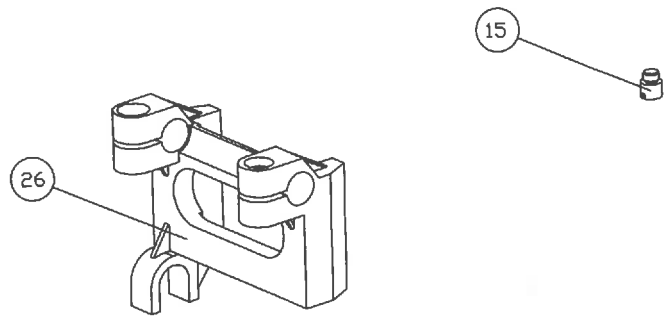
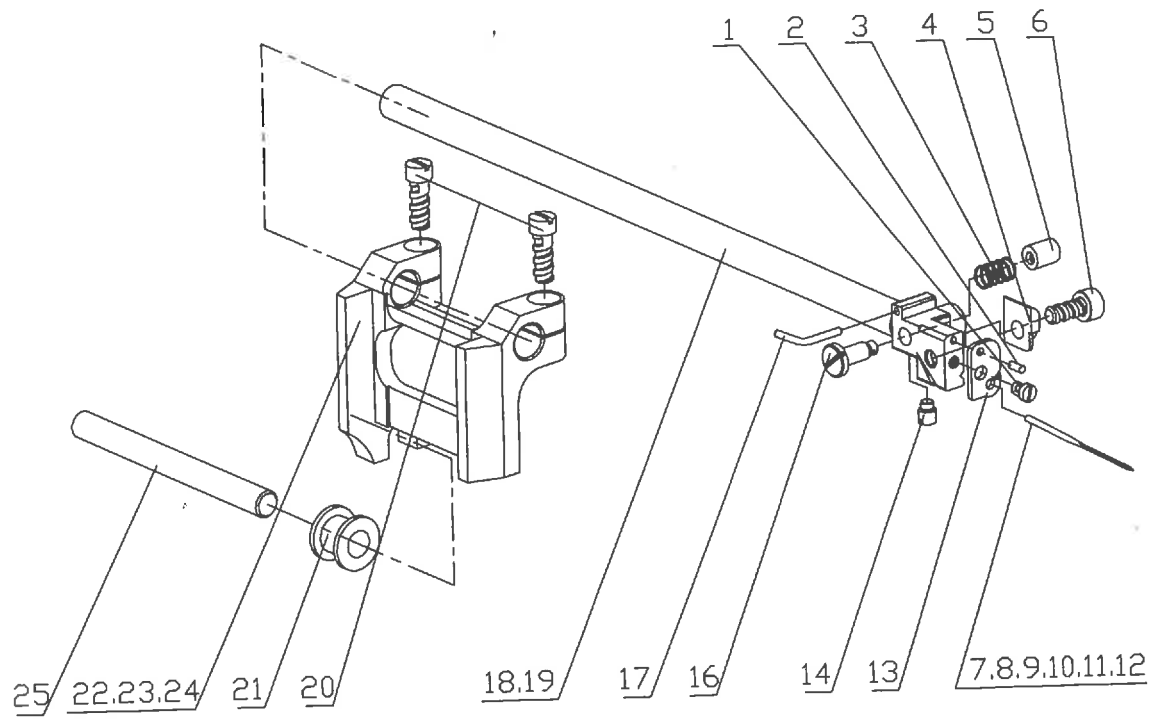

4. 针杆部件 Needle Bar Assembly

序号	零件号	零件名称	Description	4-4	4-5	4-5A	4-6	4-6A	2610	2610	1-1
1	4-1	过线板紧固螺钉 M3×4	Screw M3×4					1			
2	4-2	过线板定位销	Needle Stop Screw					1			
3	4-3	机针压线弹簧	Needle Bar Plunger Spring					1			
4	4-4	机针压板	Needle Bar Clamp Plate					1			
5	4-5	松线球面	Needle Bar Plunger Cap					1			
6	4-6	内六角圆柱头螺钉 M4×8	Screw M4×8					1			
7	4-7	机针	Needle Bar	1		0			1	1	0
8	4-8	机针	Needle Bar	0	1			0			
9	4-9	机针	Needle Bar	0		1		0			
10	4-10	机针	Needle Bar		0		1		0		
11	4-11	机针	Needle Bar		0			1			0
12	4-12	机针	Needle Bar				0				1
13	4-13	过线板	Needle Bar Front Plate					1			
14	4-14	机针限位螺钉	Screw	1		0					1
15	4-15	机针限位螺钉	Screw	0		1					0
16	4-16	压线螺钉	Needle Bar Plunger					1			
17	4-17	机针过线板	Needle Bar Thread Pin					1			
18	4-18	针杆体	Needle Nar	1		0					1
19	4-19	针杆体	Needle Nar	1		1					0
20	4-20	紧定螺钉 SM11/64×40	Lock Screw SM11/64×40					2			
21	4-21	针杆架定位轴套	Needle Bar Shaft Bush					1			
22	4-22	针杆架	Needle Bar Frame	1		0			1	1	0
23	4-23	针杆架	Needle Bar Frame					0			
24	4-24	针杆架	Needle Bar Frame	0		1					0
25	4-25	针杆架定位轴	Needle Bar Shaft					1			
26	4-26	针杆架	Needle Bar Frame				0				1

5. 钩针部件 Frame part Components

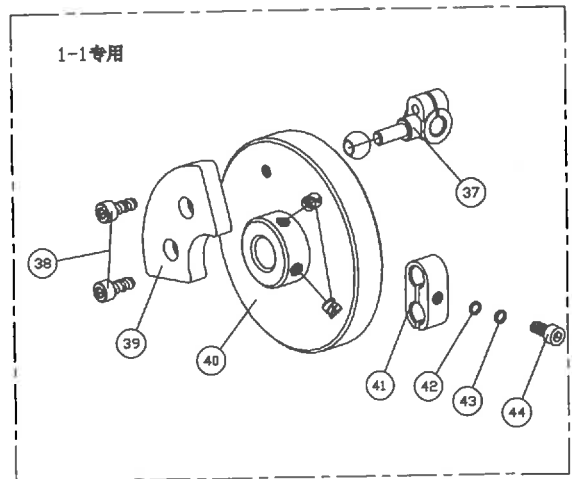
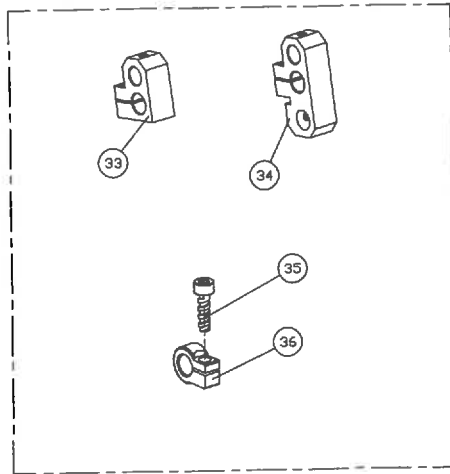
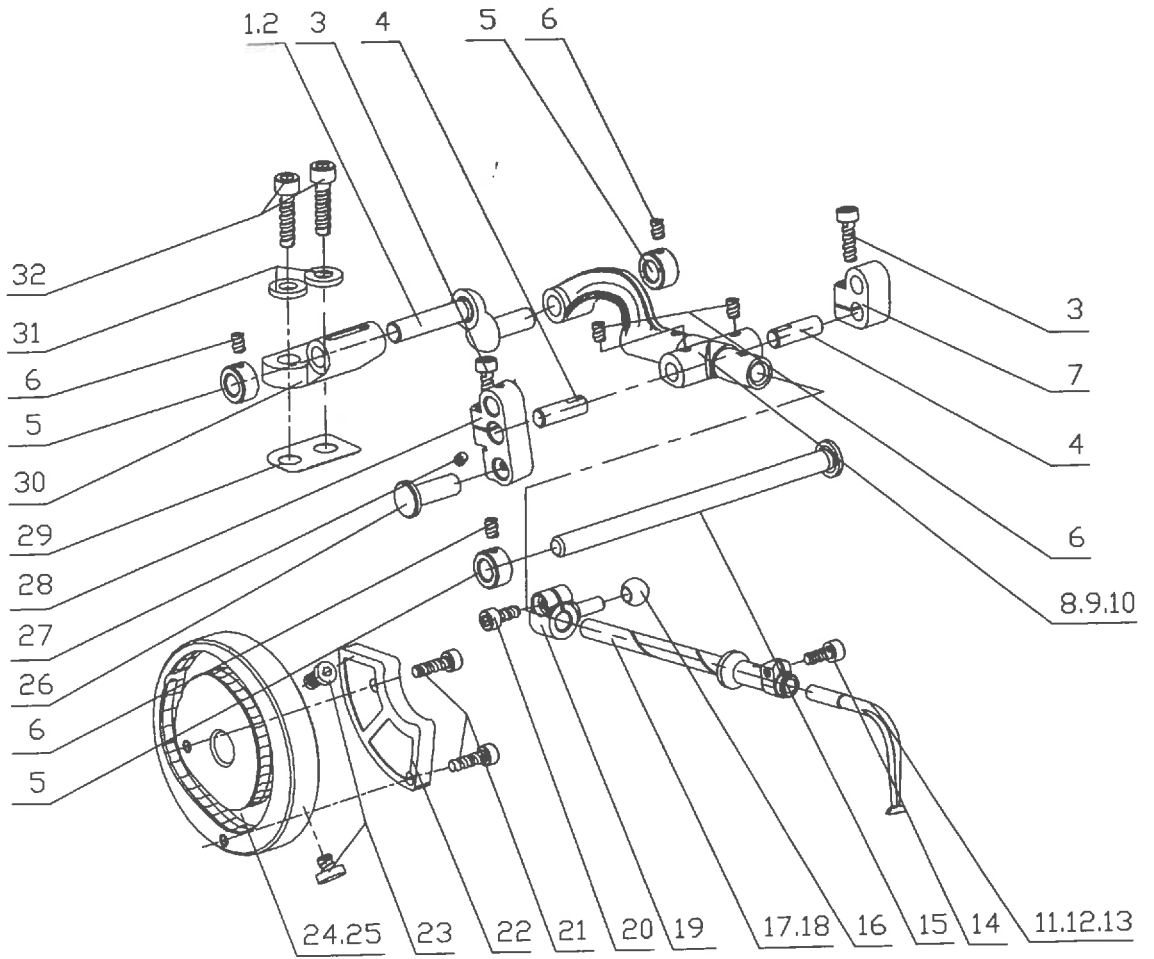

5. 钩针部件 Frame part Components

序号	零件号	零件名称	Description	4-4	4-5	4-5A	4-6	4-6A	2610	2610	1-1
1	5-1	钩针后曲柄	Crank	1			0				1
2	5-2	钩针后曲柄	Crank	0			1				0
3	5-3	内六角圆柱头螺钉 M4×10	Screw M4×10					2			
4	5-4	钩针杆座销轴	Cross Head Pin					2			
5	5-5	挡圈	Crank collar					3			
6	5-6	挡圈螺钉 SM11/64×40 L4	Screw SM11/64×40 L4					3			
7	5-7	钩针杆座曲柄夹	Short Link				1				2
8	5-8	钩针杆座	Cross Head Assy			1					0
9	5-9	钩针杆座	Cross Head Assy			0					1
10	5-10	钩针杆座	Cross Head Assy					0			
11	5-11	钩针	Looper		1		0		1	1	0
12	5-12	钩针	Looper				0				1
13	5-13	钩针	Looper		0		1				0
14	5-14	钩针杆紧定螺钉 M4×8	Screw M4×8					1			
15	5-15	钩针杆座轴	Cross Shaft					1			
16	5-16	尼龙滚珠	Cam Ball					1			
17	5-17	钩针杆	Looper Carrier		1		0				1
18	5-18	钩针杆	Looper Carrier		0		1				0
19	5-19	钩针滚珠曲柄轴	Ball Arm Assy				1				0
20	5-20	钩针滚珠曲柄轴螺钉 M4×8	Screw M4×8					1			
21	5-21	平衡块螺钉 M4×12	Screw M4×12					2			
22	5-22	平衡块	CaM Balance				1				0
23	5-23	凸轮螺钉 M5×6	Screw M5×6					2			
23	5-24	凸轮	Cam	1			0		1	1	0
25	5-25	凸轮	Cam		0		1				0
26	5-26	钩针连杆销轴	Long Link Stud					1			
27	5-27	紧定螺钉	Screw					1			
28	5-28	钩针连杆曲柄夹	Long Link					1			
29	5-29	垫片	Shims					1			
30	5-30	钩针后曲柄座	Back Brg					1			
31	5-31	垫圈	Back Brg Washer B6					2			
32	5-32	内六角螺钉 M6×20	Screw M6×20					2			
33	5-33	钩针杆座曲柄夹	Short Link					0			
34	5-34	钩针杆座曲柄夹	Long Link					0			
35	5-35	挡圈螺钉 M5×10	Screw M5×10					0			
36	5-36	挡圈	Crank collar					0			
37	5-37	钩针滚珠曲柄轴	Ball Arm Assy				0				1
38	5-38	内六角圆柱头螺钉 M5×8	Screw M5×8				0				1
39	5-39	凸轮平衡块	Cam Balance				0				1
40	5-40	凸轮	Cam				0				1
41	5-41	两眼扎头	Short Link				0				1
42	5-42	垫圈	Washer				0				1
43	5-43	弹簧垫圈	Washer				0				1
44	5-44	内六角圆柱头螺钉 M4×12	Screw M4×12				0				1

6. 送料部件 Feed Assembly

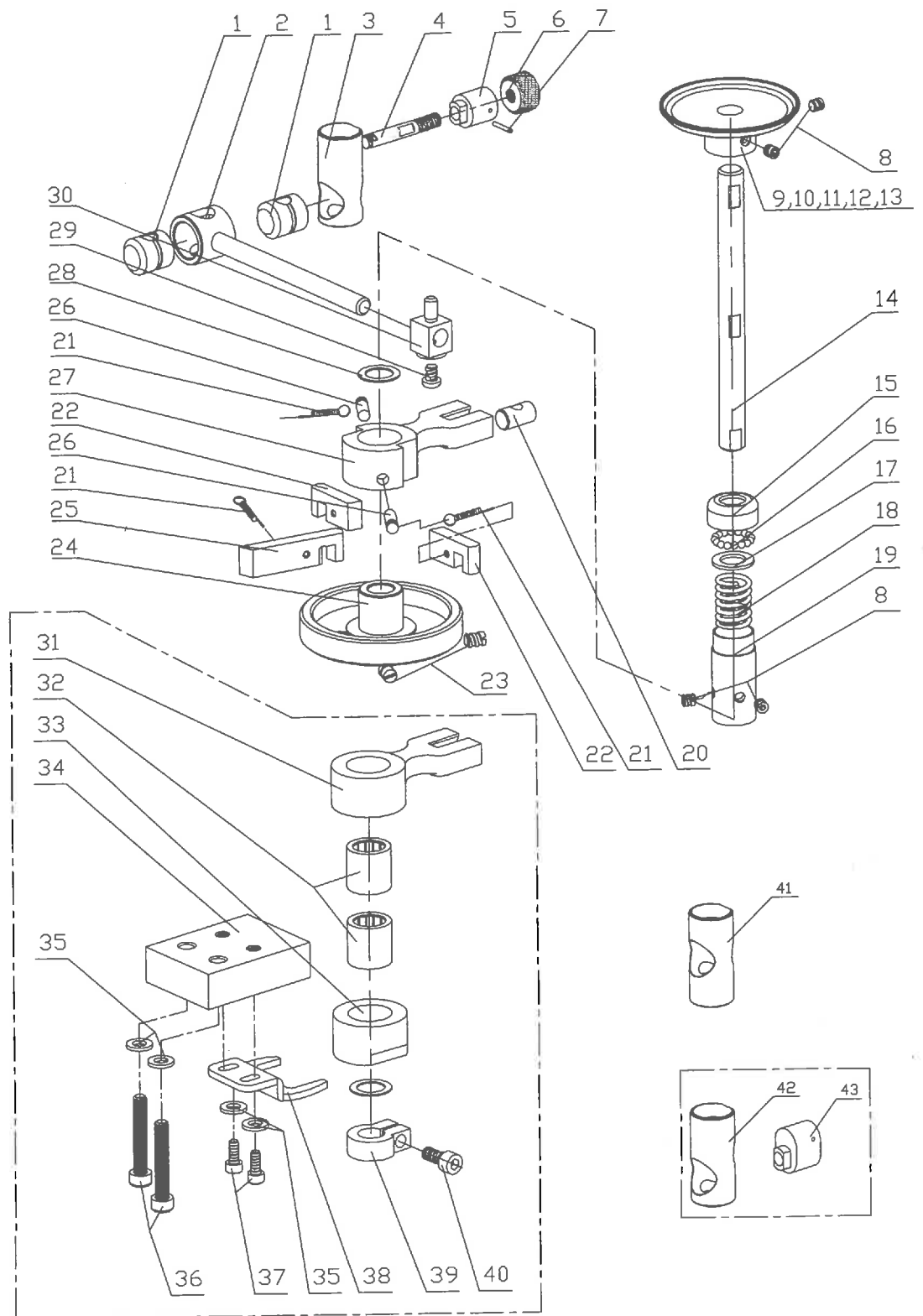

6. 送料部件 Feed Assembly

序号	零件号	零件名称	Description	4-4	4-5	4-5A	4-6	4-6A	2610	2610	1-1
1	6-1	针距调节摆轴	Piston Swivel shaft	2							
2	6-2	送料杆	Con Rod	1							
3	6-3	针距调节滑座	Piston	1	0	0	1				
4	6-4	针距调节螺杆	Piston Stud	1							
5	6-5	针距调节锁紧块	Feed Indicator	1	0	1					
6	6-6	锁紧螺母	Nut	1							
7	6-7	针距指示座销	Stitch Indicator	1							
8	6-8	一字槽紧定螺钉 M5×6	Screw M5×6	4							
9	6-9	送料盘	Back Cup	1	0	1					
10	6-10	送料盘	Back Cup	0	1	0					
11	6-11	送料盘	Back Cup	0	1	0					
12	6-12	送料盘	Back Cup	0	1	0					
13	6-13	送料盘	Back Cup	0	1	0					
14	6-14	送料轴	Back Cup Shaft	1							
15	6-15	张力簧帽	Sping cap	1							
16	6-16	滚珠 1/8	Tension Cup Ball 1/8	18							
17	6-17	张力簧垫圈	Tension cup Washer	1							
18	6-18	张力簧	Tension Spring	1							
19	6-19	张力簧座	Tension Spring Pillar	1							
20	6-20	离合器连接轴滚柱	Feed Block Roller	1							
21	6-21	离合器弹簧	Spring	3	0	3					
22	6-22	离合器传动块	Feed Grip Assy	2	0	2					
23	6-23	一字槽紧定螺钉 SM15/64×28 L8	Screw SM15/64×28 L8	2	0	2					
24	6-24	离合器传动轮	Clutch Wheel	1	0	1					
25	6-25	离合器止动块	Retaining Grip Stud	1	0	1					
26	6-26	离合器弹簧销钉	Clutch Link Vlouk Roller	1	0	1					
27	6-27	离合器主动体	Cluth	1	0	1					
28	6-28	垫圈	Washer	1	2	1					
29	6-29	半圆头螺钉 M5×6	Screw M5×6	1							
30	6-30	离合器连接轴	Clutch Link Blouk Roller	1							
31	6-31	离合器主动体	Cluth	0	1	0					
32	6-32	轴承	Bearing	0	2	0					
33	6-33	止动轮	Retaining Wheel	0	1	0					
34	6-34	新离合器垫块	New Clutch Block	0	1	0					
35	6-35	垫圈	Washer	0	4	0					
36	6-36	内六角圆柱头螺钉 M4×25	Screw M4×25	0	2	0					
37	6-37	内六角圆柱头螺钉 M4×12	Screw M4×12	0	2	0					
38	6-38	止动板	Retaining Plate	0	1	0					
39	6-39	送料夹紧	Feed Clamp	0	1	0					
40	6-40	内六角圆柱头螺钉 M5×12	Screw M5×12	0	1	1					
41	6-41	针距调节滑座	Piston	0	1	0	0				
42	6-42	针距调节滑座	Piston	0	0	1	0				
43	6-43	弹簧垫圈	Washer	0	0	1	0				

7. 压料部件 Arms and Cups

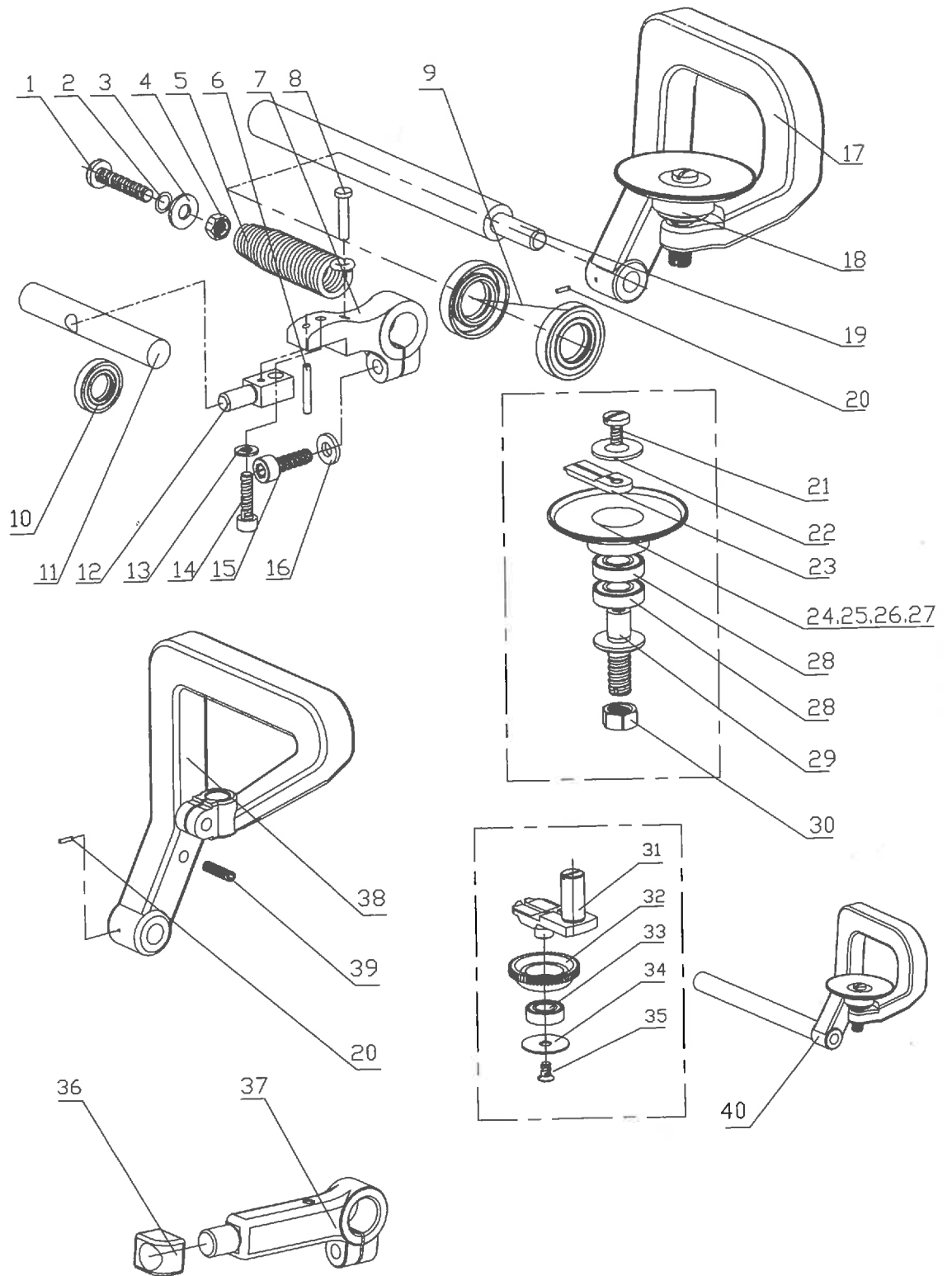

7. 压料部件 Arms and Cups

序号	零件号	零件名称	Description	4-4	4-5	4-5A	4-6	4-6A	2610	2610	1-1
1	7-1	拉簧调节螺钉 M6×50	Screw M6×50					1			
2	7-2	O型密封圈	Stich Φ9×1.9					1			
3	7-3	垫圈	Washer 6					1			
4	7-4	拉簧螺母 M6	Arm Spring Adjusting Nut					1			
5	7-5	拉簧	Arm					1			
6	7-6	拉簧连接块圆柱销	Stitch					1			
7	7-7	拉簧连接架	Arm Spring Adjusting Nut		1				0		1
8	7-8	拉簧销	Stitch					1			
9	7-9	压料轴油封	Skeleton Oil Seal					0			
10	7-10	压料活动轴油封	Skeleton Oil Seal		0			1			0
11	7-11	压料活动轴	Spresser					1			
12	7-12	压力活动轴连接块	Link block		1				0		1
13	7-13	垫圈	Crank collar		1				0		1
14	7-14	内六角圆柱头螺钉 M5×16	Screw M5×16					1			
15	7-15	拉簧连接架螺钉 M6×20	Screw M6×20					1			
16	7-16	垫圈	Washer 6					1			
17	7-17	压料支架	Arms Assy		1				0		1
18	7-18	压料盘组件	Big Front SiscSet					1			
19	7-19	压料轴	Spresser		1			0			1
20	7-20	固定销	Solidification			1			0		1
21	7-21	轴承压板螺钉 M5×9	Screw M5×9		1			0			1
22	7-22	轴承压板	Dust Seal Washer		1			0			1
23	7-23	护针板	Needle Plate	0		1			0		
24	7-24	压料盘	Needle Plate Cup	1			0				1
25	7-25	压料盘	Needle Plate Cup	0	1				0		
26	7-26	压料盘	Needle Plate Cup	0		1			0		
27	7-27	压料盘	Needle Plate Cup		0			1			0
28	7-28	轴承	Bearing		2			0			2
29	7-29	压料盘连接轴	Front Cup Spindle		1			0			1
30	7-30	压料盘连接螺母 M10	Front Cup Spindle M10		1			0			1
31	7-31	压料盘轴	Needle Guard Plate		0			1			0
32	7-32	小压料盘	Small Pressing Cup		0			1			0
33	7-33	轴承	Bearing		0			1			0
34	7-34	垫圈	Washer		0			1			0
35	7-35	沉头螺钉 M3×6	Screw M3×6		0			1			0
36	7-36	滑块	Side Block		0				1		0
37	7-37	拉簧连接架	Pressure Lever		0				1		1
38	7-38	压料支架	Arms Assy		0			1			0
39	7-39	限位螺钉 M6×45	Screw M6×45		0			1			0
40	7-40	压料支架	Arms Assy			0			1	1	0

8. 润滑部件 Lubrication System and cotton stand

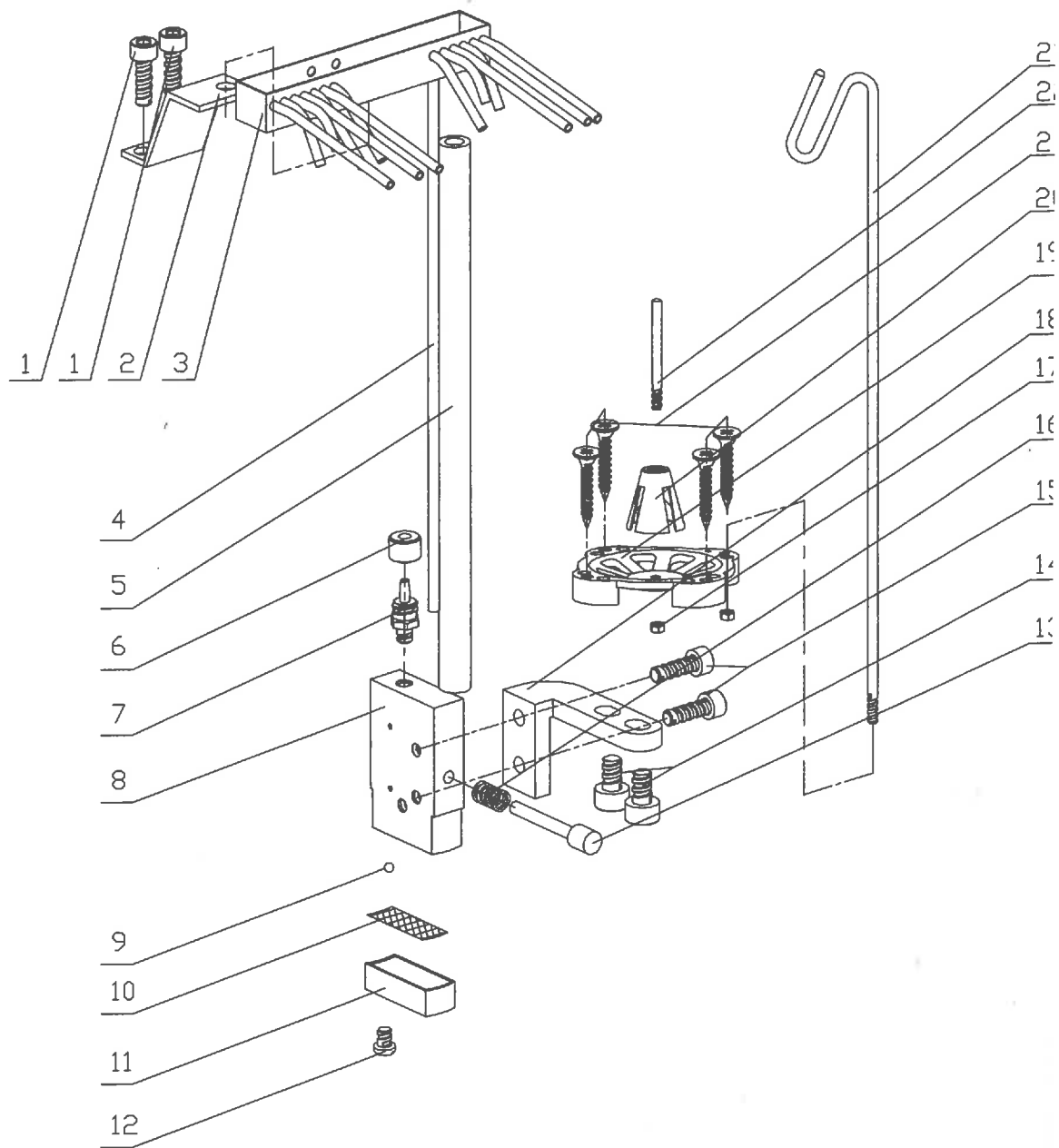

8. 润滑部件 Lubrication System and cotton stand

序号	零件号	零件名称	Description	4-4	4-5	4-5A	4-6	4-6A	2610	2610	1-1
1	8-1	内六角圆柱头螺钉 M6 10	Screw M6 10					2			
2	8-2	分油箱支架	Sub-fuel tank bracket					1			
3	8-3	分油箱部件	Oil distributor					1			
4	8-4	上油管	The tubing					1			
5	8-5	回油管	Return pipe					1			
6	8-6	油管接头帽	Tubing connector cap					1			
7	8-7	油管接头	Tubing connector					1			
8	8-8	油泵体	pump					1			
9	8-9	钢珠	Steel ball					0			
10	8-10	滤网	Thread Guide Stud					1			
11	8-11	滤网套	Lube Sleeve And Net					1			
12	8-12	圆柱头螺钉 M5 6	Screw M5x6					1			
13	8-13	活塞	pistons					1			
14	8-14	内六角圆柱头螺钉 M6 16	Screw M6x16					2			
15	8-15	内六角圆柱头螺钉 M5 16	Screw M5x16					2			
16	8-16	油泵弹簧	Oil pump spring					1			
17	8-17	螺母	Nut M6					2			
18	8-18	油泵支架	Pump bracket					1			
19	8-19	线架座	Wire frame seat					1			
20	8-20	线圈定位套	Coil positioning units					1			
21	8-21	线架座定位螺钉	Screw					4			
22	8-22	插线杆	Insert pole					1			
23	8-23	过线杆	Off polein					1			