



WHYTE
PERFORMANCE BY DESIGN

www.whyte.bike 

MTB Full Suspension Range

G-170 Gravity Enduro Suspension - 170mm

S-150 Trail/Enduro Suspension - 150mm

T-130 Trail Suspension - 130mm

S-120 Trail Suspension - 120mm

Supplementary Service Manual 2019 Edition 1

Table of Contents

1.0 Introduction

2.0 Geometry

3.0 Preparations for riding:

- 3.1 Making Adjustments
- 3.2 Whyte Inter Grip Seat Clamp Adjustment
- 3.3 Set up of Fork
- 3.4 Set up of Rear Damper
- 3.5 Suspension Tuning Log

5.0 Safety.

5.0 Lubrication:

- 5.1 Whyte Inter Grip Seat Clamp
- 5.2 General Lubrication

6.0 Servicing the Rear Suspension:

- 6.1 Removing the Rear Shock and Swinging Arm.
 - 6.1.1 Remove the Rear Shock only.
 - 6.1.2 Remove the other rear suspension parts.
 - 6.1.3 Remove the chain-stay & bearings from the Main Frame
- 6.2 Stripping and Re-assembling Other Rear Suspension Bearings
 - 6.2.1 Extraction of Bearings
 - 6.2.2 Insertion of Bearings
 - 6.2.3 Re-Assembly of Shield Washers / Spacers
- 6.3 Re-assembling the Rear Suspension
 - 6.3.1 Re-Assembly of the Rear Suspension.
 - 6.3.2 Insert the bearings into the Main Frame, plus assemble the chain-stays to the Main Frame.
 - 6.3.3 Re-assemble the other rear suspension parts.
 - 6.3.4 Re-assemble the Rear Shock into the Main Frame.

7.0 Servicing the Whyte Modular Dropout Systems:

- 7.1 Disassembly of Modular Rear Dropouts.
 - 7.1.1 Shimano E-Thru
 - 7.1.2 SRAM Maxle 148mm
- 7.2 Reassembly of Modular Rear Dropouts.
 - 7.2.1 Shimano E-Thru
 - 7.2.2 SRAM Maxle 148mm

8.0 Servicing the Whyte Inter Grip Seat Clamp

9.0 Fitting Internal Cables & Hoses.



WHYTE Service Manual

Table of Contents (continued)

- 9.1 To replace cable or hose outers.
- 9.2 To fit a "Dropper" seat-post with internal hose.

10.0 Torque Settings.

11.0 Owner's Notes

1.0: INTRODUCTION

Thanks for choosing to purchase this Whyte product. We hope you will enjoy all the benefits its advanced design and engineering will bring to your riding experience.

This manual will guide you through the set-up, safety and maintenance procedures that are specific to your Whyte bike. For other more general information, we strongly advise that you also read thoroughly the General Instruction Manual that is also supplied with your new bike.

Also, please note that the specification of all the components that are fitted to your bike as standard may be obtained from the Whyte Bikes Brochure or alternatively from the Whyte Bikes website **www.whyte.bike.co.uk**

Please remember, if you are in any doubt about your ability to safely service or repair your Whyte bike, do not ride it and instead arrange for a professional bicycle mechanic at your local Whyte dealer to do the job correctly.

Bundled with this manual, are the respective manufacturers instructions and manuals for the branded parts that are fitted to your Whyte bike. Please take time to study all the relevant instruction manuals to ensure you have a continually safe and well set-up bike before every ride, and to help you build up a relationship of knowledge between you and your Whyte Dealer.

Happy and safe riding,

Whyte design team. January 2017.

2.0: GEOMETRY

The geometry of the full suspension range of Whyte Bikes is available from the Whyte Bikes website **www.whytebike.co.uk**

WHYTE Service Manual

3.0: PREPARATIONS FOR RIDING

3.1: MAKING ADJUSTMENTS

Please refer to the specific component manufacturer's manual or published technical information about adjusting the components on your Whyte bike. Instructions may be downloaded from the relevant manufacturer's internet site, as shown in the table to the right.



CAUTION! If you are uncertain in any way, about making adjustments to any components on your Whyte bike, then **DO NOT RIDE YOUR BIKE.**

Contact your Whyte dealer who will be able to advise you on how to go about setting up your Whyte bike for riding, and or making adjustments to the components fitted to your Whyte bike.

DT Swiss	www.dtswiss.com
Easton	www.eastonbike.com
Formula	www.formulahubs.com
Fox	www.foxracingshox.com
Hope	www.hopetech.com
Joytech	www.joytech.co.tw
Maxxis	www.maxxis.com
Race Face	www.raceface.com
Shimano	www.shimano.com
SR Suntour	www.srsuntour-cycling.com
SRAM	www.sram.com
Tektro	www.tekro.com
WTB	www.wtb.com

3.2: WHYTE INTER GRIP SEAT CLAMP ADJUSTMENT & SERVICE

Tools Required: 5mm AF Allen Keys (2 off, 1 fitted to a 3Nm to 15Nm Torque Wrench)
Small Size Flat Blade Screwdriver
SKF LGEP2 or Castrol Spherol AP3 or Finish Line Teflon White Lithium Complex grease

Reference figures 2 to 7 plus the assembly in figure 37. The Inter Grip seat clamp design is present on most models of Whyte full suspension mountain bikes. It allows adjustment of the saddle height & direction.



CAUTION! Avoid over-tightening the seat clamp.

In particular, "dropper" seat-posts such as SRAM Reverb may not work correctly if the seat clamp is over tightened.

Figure 1. To adjust the seat height and/or direction, using the 5mm Allen key, undo the M6 Capscrew (1) just enough to allow the Seat Post (7) to slide freely up and down. Set the height and/or direction to the desired level.

Figure 2. Re-tighten the M6



WHYTE Service Manual

Capscrew (1) with the 5mm Allen Key in the Torque Wrench to the 14Nm limit, as marked on the Plain Sleeve (2).

Figures 3 & 4. If a "dropper" seat-post is fitted, simultaneously depress the activation trigger and press down on the saddle to compress the seat-post until it is fully down. Then release the activation trigger and the seat-post should rise up automatically.

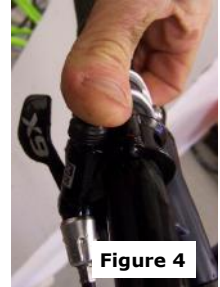



Figure 5. If this does not happen, gradually loosen the M6 Cap-screw (1) with the 5mm Allen Key below the 14Nm limit, until the seat-post rises automatically.



Figure 6. Then firmly twist the saddle to confirm the seat-post is still securely gripped by the lowered torque value that allows the "dropper" seat-post to function correctly.

 **CAUTION!** When adjusting the saddle height you **MUST** obey the Minimum insertion depth requirement marked on the Seat Post (7). Also consult the seat-pin manufacturer's instructions in conjunction with these notes.

3.3: SET UP OF FORK

Tools Required: *Good Quality Shock Pump.*
 Small Ruler

The front suspension fork fitted to your Whyte bike will be pre-set with the standard settings. Before riding, you may need to adjust these setting. First is the Sag setting on the fork. This is to ensure the forks are set-up correctly for your own body weight, so the fork will perform as intended.

To set Sag on the front fork, you need to measure the amount the fork compresses when you sit on the bike in the normal riding position. See the table on the right for our recommendation of front fork sag on your Whyte bike. To achieve this you will need to adjust the air spring pressure inside the fork.

Refer to the specification tables in this manual, and then to the relevant fork manufacturers set up instructions to find how to adjust the air spring pressure in the fork. Using a shock

WHYTE Service Manual

pump, either add or remove air until Sag is correctly set.

Please note that for the detailed instructions for servicing and all matters relating to the forks fitted to your Whyte bike, please refer to the manufacturers instructions.

Rebound Damping adjustment:

This adjustment fine-tunes the speed at which the wheel returns to its normal ride height after hitting a bump. Refer to the relevant manufacturers instructions to find out how to adjust the rebound damping. To demonstrate the effect of this function, turn the adjuster to its slowest setting. Press down on the handlebars to compress the forks, then release the load. The suspension recovers very slowly to its original position.

Model	Sag (15% - Firm)	Sag (25% - Plush)
T-130	19.5mm	32.5mm
S-150	22.5mm	37.5mm
G-170	24mm	40mm

Repeat the above with the adjuster turned to the fastest setting and the difference will be seen immediately the load is released. We recommend the optimum setting is to adjust the re-bounce damping to be as slow as possible, but not so slow that the normal ride height is not recovered. On very rough terrain, if the bike becomes progressively lower as more bumps are hit then the rebound damping is set too slow. On the other hand if the bike feels choppy and not plush then the re-bounce damping is too fast. A bit of trial and error is needed to get the exact setting.



IMPORTANT SAFETY NOTE:

Always stop riding when making adjustments of any kind to the bicycle!

3.4: SET UP OF REAR DAMPER

*Tools Required: Good Quality Shock Pump.
Small Ruler*

Your Whyte bike is fitted with an air spring rear shock absorber. This means that the air pressure in the shock absorber determines the spring rate. The correct 'sag' can be found using the sliding 'O' ring fitted to the shaft of the shock piston. Slide the 'O' ring against the shock body. Then gently sit on the bike in your normal riding position and with normal riding gear, including back pack if applicable, and also raise your feet off the floor. Carefully dismount and measure the distance the 'O' ring has moved away from the shock body. pressure.

The optimum distance for the Quad-Link rear suspension system is shown in the table to the right. If there is less than that distance fit a shock pump and release air pressure. Conversely if there is greater than that distance, fit the shock pump and increase air pressure. Repeat the 'sag' test until the recommended sag distance is achieved.

Rear Suspension Set-up - Rebound Damping:



WHYTE Service Manual

When the damper unit is being compressed, this is known as the compression stroke. As the suspension unit recovers from compression back towards its full length, this is called the re-bounce stroke. All the shocks fitted as standard to the Whyte full suspension mountain bikes have factory set compression damping, and manually adjustable rebound damping.

Rebound Damping Adjustment:

The advice in section 3.3 about the fork rebound damping adjustments also applies to the rear shock.



IMPORTANT SAFETY NOTE:

Always stop riding when making adjustments of any kind to the bicycle!

Model	Sag
S-120C	13mm (25%)
T-130 & S-150	17mm (25%)
G-170	19mm (30%)

Platform Damping Adjustment.

The rear Shock fitted to your Whyte bike may have a “platform” facility to adjust the slow speed compression damping, eg Fox “3pos w/Adj” or SRAM RockShox “Motion Control”. Please refer to the relevant shock manufactures technical information to learn how to adjust these features.

Please note, that the Whyte rear suspension systems have been designed not to rely on excessive low speed compression damping to obtain efficient pedalling performance, and turning on too much low speed damping on the rear shock will compromise the suspensions sensitivity to small bump absorption and traction.

3.5: SUSPENSION TUNING LOG

Record your best suspension settings in the table below, to restore them if necessary, eg. after dealer servicing of the suspension or if a friend has borrowed your bike.

Date	Rider Weight (including all riding kit) (kg or lbs)	Fork Pressure (bar or P.S.I)	Fork Rebound Damping (# of clicks from softest setting)	Shock Pressure (bar or P.S.I)	Shock Rebound Damping (# of clicks from softest setting)

WHYTE Service Manual

4.0: SAFETY

IMPORTANT: The following are intended to be advisory notes on the safe use of your Whyte bike. You should also read thoroughly the General Instruction Manual also supplied with your new bike. If at any stage you are uncertain about the safety or safe operation of the bike as a whole, or any specific component, then **DO NOT RIDE YOUR WHYTE** and instead please consult the specific component manufacturers instruction manual or your Whyte Dealer for advice.

Maximum Weight Limit for Whyte G-170C, G-170, S-150C, S-150, T-130C or T-130: 18st. / 114kg (including rider's luggage)



WARNING: As is the case with all mechanical components, the bicycle is subjected to wear and high stresses. Different materials and components may react to wear and stress fatigue in different ways. If the design life of a component has been exceeded, it may fail suddenly causing possible injury to the rider. Any form of crack, scratches and decolouring in highly stresses areas are showing that the component has exhausted its life time and has to be replaced. If you are in any doubt about one or more components on your Whyte **DO NOT RIDE YOUR BIKE**. Consult the specific component manufacturers literature, or take your bike to your local Whyte Dealer.

Designed for the following use:

The Whyte G-170C, G-170, S-150C, S-150, T-130C & T-130 bicycles have all been designed, tested and comply with ISO 4210-2 Safety Standard, for typical free-ride or gravity enduro mountain biking use. They have not been designed or tested for extreme down-hilling.

5.0: LUBRICATION

Please refer to the Whyte General Instruction Manual for guidance about lubricating many of the components on your Whyte bicycle.

For the range of bicycles contained in this Supplementary Service Manual, there is also the following specific guidance:



WHYTE Service Manual

5.1: WHYTE INTER GRIP SEAT CLAMP

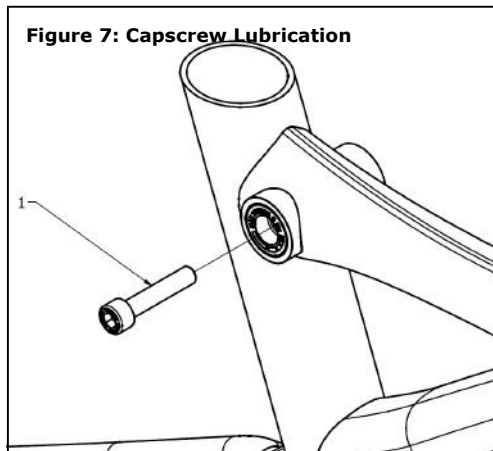

Item	Description	Lubricant	Lubrication Interval
1	M6 x 30mm Capscrew	SKF LGEP2 or Castrol Spherol AP3 or Finish Line Teflon White Lithium Complex grease	Once a Month

5.2: GENERAL WHYTE LUBRICATION

For the correct lubrication regime and maintenance of all parts on a Whyte bicycle, please refer to the specific component manufacturers detailed instructions bundled with this manual or for further information visit the specific manufacturers website.

6.0: SERVICING THE REAR SUSPENSION

6.1: Remove the Rear Shock, Links & Swinging Arm:

Tools Required:

- 4mm AF Allen Keys (2 off)
- 5mm AF Allen Key - ball ended (1 off)
- 6mm AF Allen Key (1 off)
- 8mm AF Allen Key (1 off)
- T-25 Torx® Keys (2 off)

6.1.1 To remove only the rear shock absorber (6) from the frameset.

Whilst referencing figure 8, using the T-25 Torx® Keys, undo the two M5 x 16mm long Socket-head Capscrews (1) from the Ø8mm x 31mm long Hollow Pivot Pin (3) that passes through the Main Frame (15) and front of the Rear Shock Absorber (6). Whichever Capscrew (1) becomes undone first, remove it and the adjacent Collar (2), and pull the Pivot Pin (3) all the way out from the other side.

Figure 8: Disassembly of the Rear Suspension (First Stage)

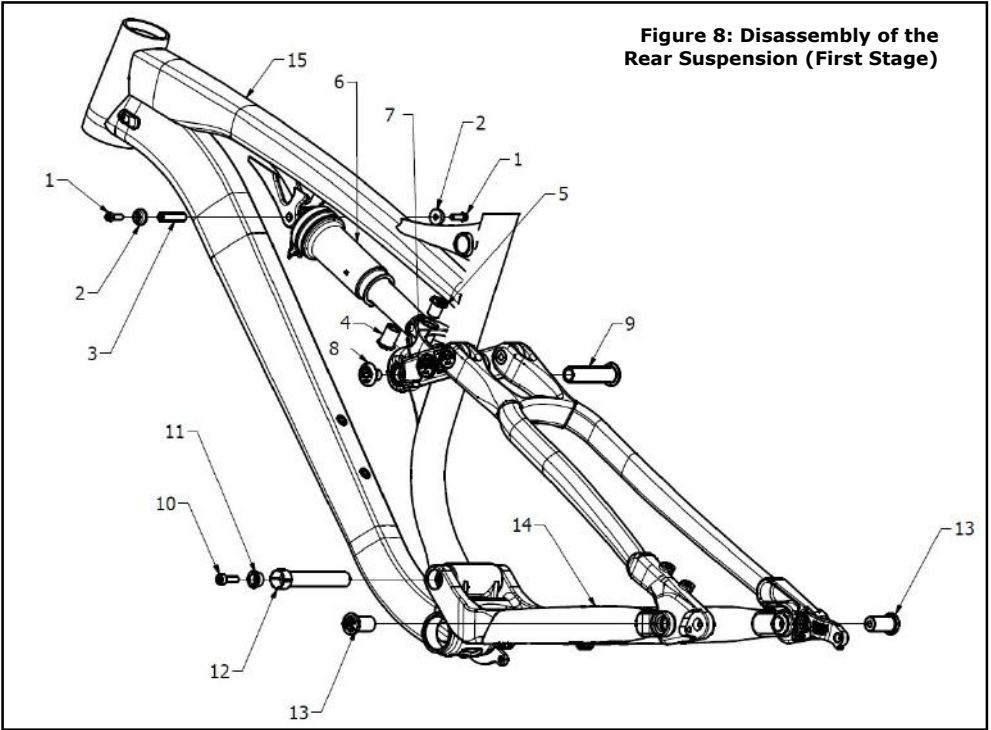

**Figure 9: Disassembly of the Rear Suspension (Second Stage)
(Note: Main Frame 15 not shown for clarity)**

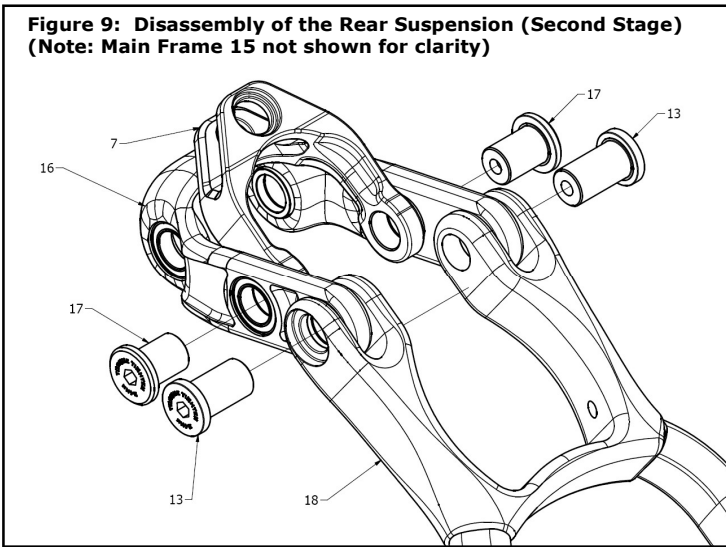

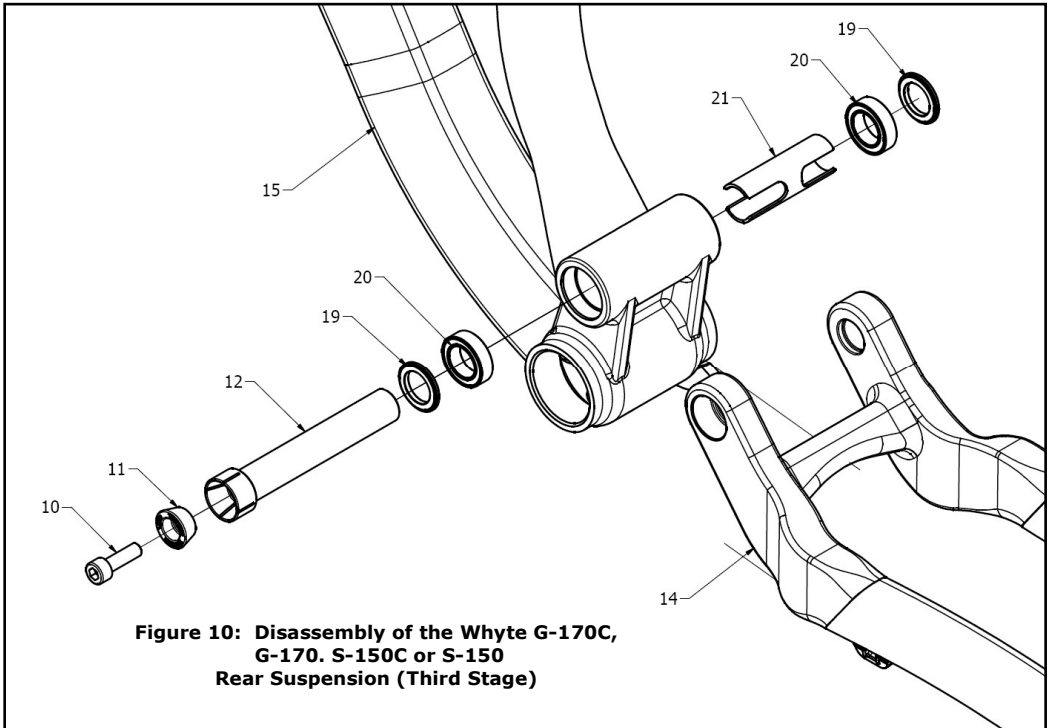

Figure 10: Disassembly of the Whyte G-170C, G-170, S-150C or S-150 Rear Suspension (Third Stage)

Using the 6mm AF Allen Key and the 8mm AF Allen Key, undo and remove both the Flanged Nut M12 x 19mm long (4) from the Flanged Screw M12 x 15mm long (5), that pass through the Shock Extender (7) and the rear of the Rear Shock Absorber (6). You can now remove the Rear Shock Absorber (6).

6.1.2 To remove the Link (16) & swinging arm (14) from the main frame (15).

Whilst referencing figure 9, using the 6mm AF Allen Key, unscrew and remove the M12 x 20 long Pivot Screw (8) & the Pivot Pin (9) at the front of the Link (16).

Next, using the 6mm AF Allen Key, unscrew and remove the two M15 x 28 long Pivot Screws (13) at the rear of the chain-stays (14). Be careful to retain all the shield washers (Items 2 & 3, Figure 14) ready for re-assembly.

To separate the Seat-stays (14) from the Link (16) and Main Frame (15), whilst referencing figure 10, using the 6mm AF Allen Key, unscrew and remove the two M15 x 28 long Pivot Screws (13) at the front of the Seat-stays (18). The Seat-stays (18) may now be removed from the Link (16). Finally to remove the shock extender (7) from the Link (16), using the 6mm AF Allen Key, unscrew and remove the two M15 x 20 long Pivot Screws (17). Be careful to retain all the shield washers (Items 2 & 3, Fig 14) ready for re-assembly.

WHYTE Service Manual

Item	Description
1	M5 x 16mm long Socket-head Capscrew (T-25 Torx®)
2	Collar for M5 Capscrew
3	Hollow Pivot Pin Ø8mm x 31mm long
4	Flanged Nut M12 x 19mm long
5	Flanged Screw M12 x 15mm long
6	Rear Shock Absorber
7	Shock Extender
8	M12 x 20 long Pivot Screw (6mm A/F Internal Hex)
9	Pivot_Pin_link_mount-61lg
10	M6 x 20 long Capscrew (5mm A/F Internal Hex)
11	Tapered Sleeve for Expanding Collet
12	Pivot Pin 80mm long, expanding collet, M15 thread.
13	M15 x 28 long Pivot Screw (6mm A/F Internal Hex)
14	G-170C, G-170. S-150C or S-150 Chain-stays
15	G-170C, G-170. S-150C or S-150 Main Frame
16	Rear Suspension Link, 99mm centre – to – centre
17	M15 x 18 long Pivot Screw (6mm A/F Internal Hex)
18	G-170C, G-170. S-150C or S-150 Seat-stays
19	Shield Washer (O.D. 23mm)
20	Bearing (Enduro 6802-2RS-MAX)
21	Internal Spacer (49mm long)

6.1.3 To remove the Chain-stays (14) and Bearings (20) from the main frame (15).

Whilst referencing figure 10, using the 5mm A/F Allen Key, partially unscrew the M6 x 20 long Cap-screw (10) from the Pivot Pin 80mm long, expanding collet, M15 thread (12). Using the 6mm AF Allen Key, unscrew and remove the Pivot Pin 80mm long, expanding collet, M15 thread (12). The cap-screw (10) may now be completely removed, to allow the tapered sleeve (11) to be released from the collet (12).

The Chain-stays (14) may now be removed from the Main Frame (15). Be careful to retain the two shield washers (19) ready for re-assembly.

Using the press tools shown in Figure 19, extract the Enduro 6802-2RS-MAX bearings (20) from

WHYTE Service Manual

both sides of the Main Frame (15). Align the removal tool carefully with the slots in the Spacer (21).

6.2: STRIPPING AND REASSEMBLING OTHER BEARINGS.

(Reference figures 11 & 12)

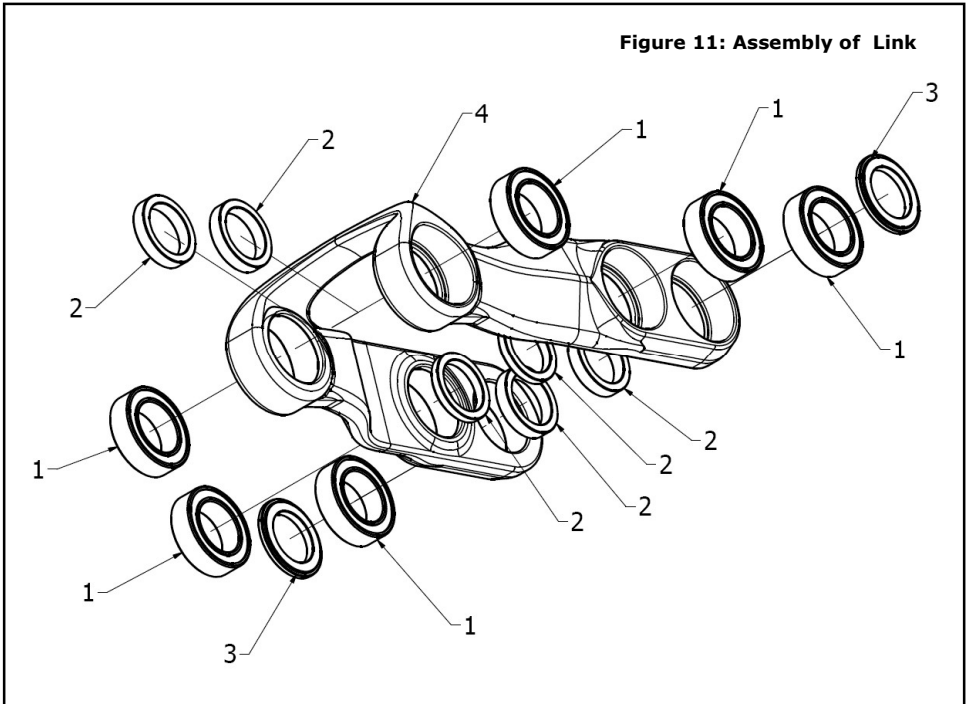

Item	Description
1	ID 15mm, OD 24mm, Width 5mm, bearing (Enduro 6802-2RS-MAX)
2	Shield washer (O.D. 20mm)
3	Shield washer (O.D. 23mm)
4	Various centre-to-centre dimensions Alloy Link Bodies

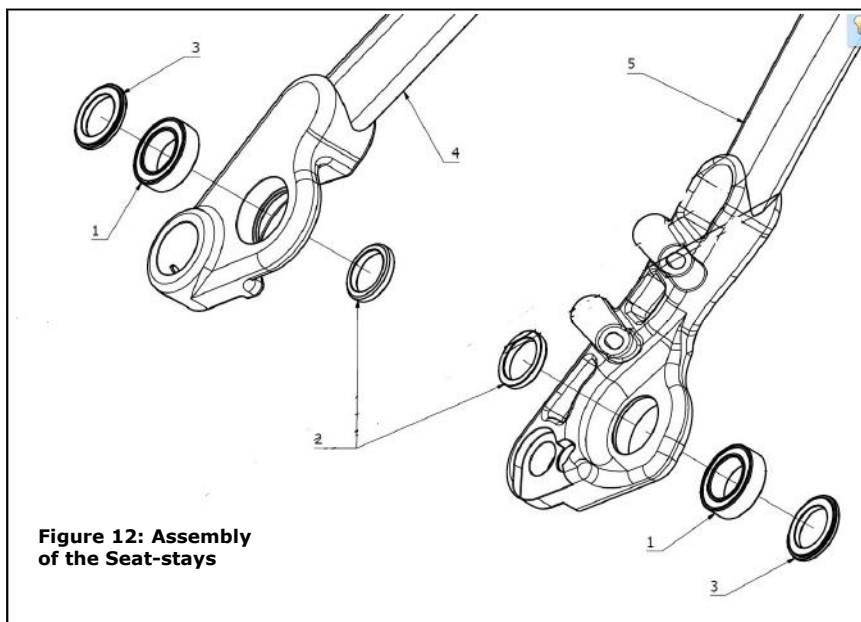
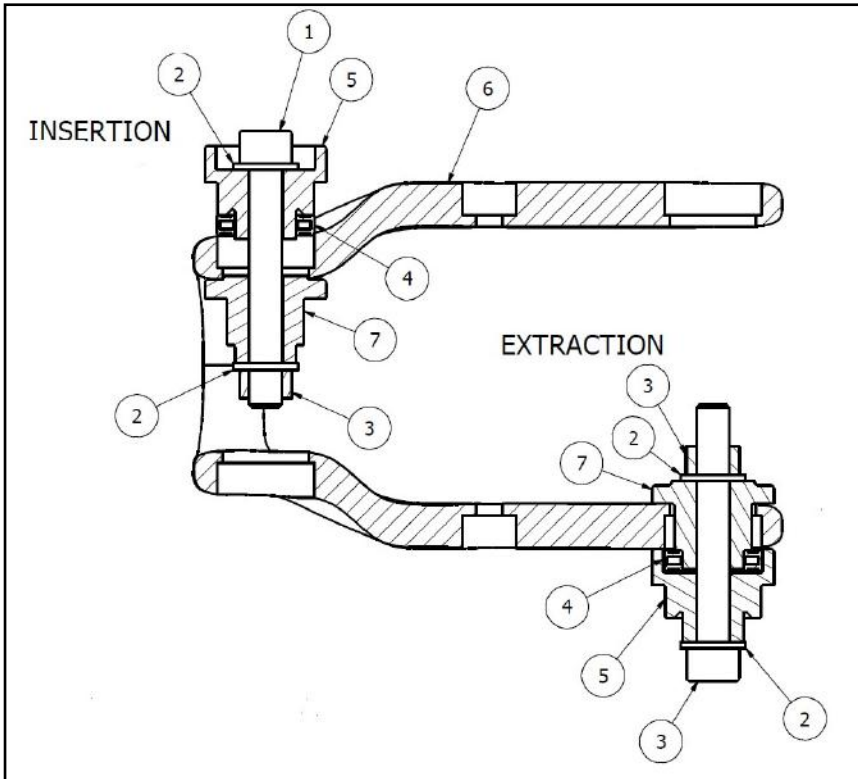

Figure 12: Assembly of the Seat-stays

Item	Description
1	ID 15mm, OD 24mm, Width 5mm, bearing (Enduro 6802-2RS-MAX)
2	Middle shield washer (O.D. 20mm)
3	Outer shield washer (O.D. 23mm)
4	Right Seat-stay
5	Left Seat-stay

WHYTE Service Manual

**Figure 13: Bearing Insertion & Extraction 6802-2RS-MAX
(Link or Rear of Seat Stay)**



Item:	Description.
1	M8 Capscrew ISO4162 55 long
2	M8 Washer ISO 7089
3	M8 Nut ISO 4032
4	Enduro 6802-2RS-MAX Bearing
5	Enduro 6802-2RS-MAX Bearing Tool 1
6	Mating Component (ie: Link or Seat-Stay)
7	Enduro 6802-2RS-MAX Bearing Tool 2

WHYTE Service Manual

**Figure 14: Bearing Insertion & Extraction 6802-2RS-MAX
(Above Main Frame Bottom Bracket)**

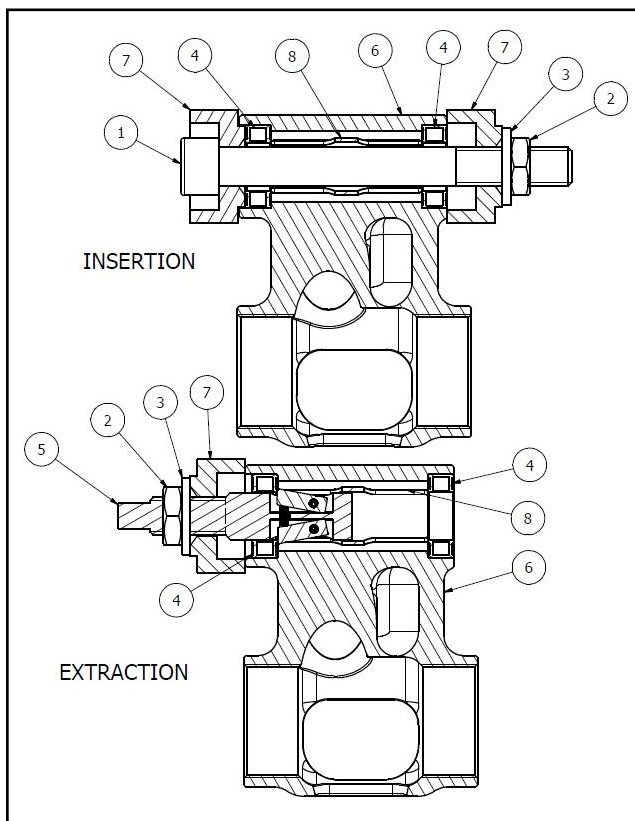

Item:	Description.
1	M8 Capscrew ISO4762 55 long
2	M12 Nut ISO 4035
3	I. D. 12 Washer ISO 7089
4	Enduro 15826-2RS-MAX Bearing
5	Enduro 15826-2RS-MAX Bearing Tool 1
6	Mating Component (ie: Bottom Bracket Yoke)
7	Enduro 15826-2RS-MAX Bearing Tool 2
8	Internal Bearing Spacer

& 13). If you have applied enough grease, it should spread from under the shield washer or spacer components as they are positioned. Wipe this excess grease away from around the shield washer or spacer components.

APPLICATION OF "SKF LGAF 3E" or "Castrol Optimol T" ANTI-FRET PASTES

Once the link & swinging arm components have been assembled correctly, either SKF LGAF 3E or Castrol Optimol T paste **must** be applied to all outside faces of the shield washer components (Items 2 & 3 in Figures 13, 14 & 16 or item 2 in Figures 15 & 17) that contact the Main Frame and Swinging Arm. It is additionally recommended to apply anti-fret paste to the mating contact surfaces on the Main Frame and Swinging Arm.

6.3: RE-ASSEMBLING THE REAR SUSPENSION.

6.3.1: Re-assemble the Rear Suspension

Tools Required: 5mm AF Allen Keys (2 off, 1 fitted to a 5Nm to 25Nm Torque Wrench)
6mm AF Allen Key (2 off, 1 fitted to a 5Nm to 25Nm Torque Wrench)
T-25 Torx® Keys (2 off, 1 fitted to a 5Nm to 25Nm Torque Wrench)

Reference figures 15, 16, 17 & 18. The re-assembly of the rear suspension is essentially the reverse of the dis-assembly procedures 6.1.1, 6.1.2 & 6.1.3.

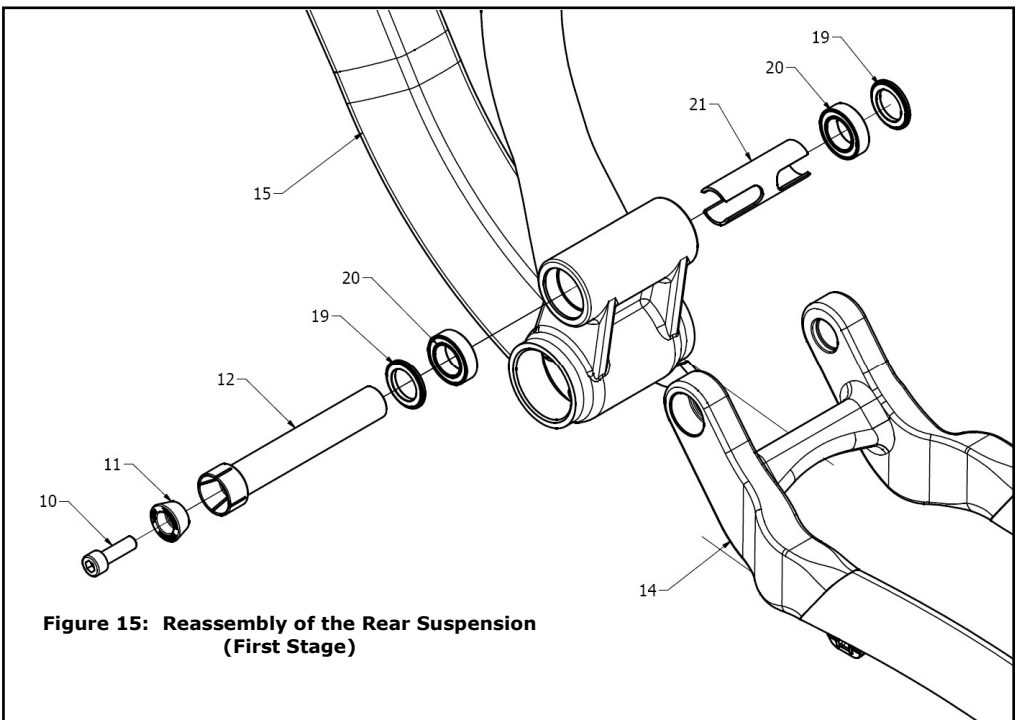

**Figure 15: Reassembly of the Rear Suspension
(First Stage)**

WHYTE Service Manual

Figure 16: Reassembly of the Rear Suspension (Second Stage)
(Note: Main Frame 15 not shown for clarity)

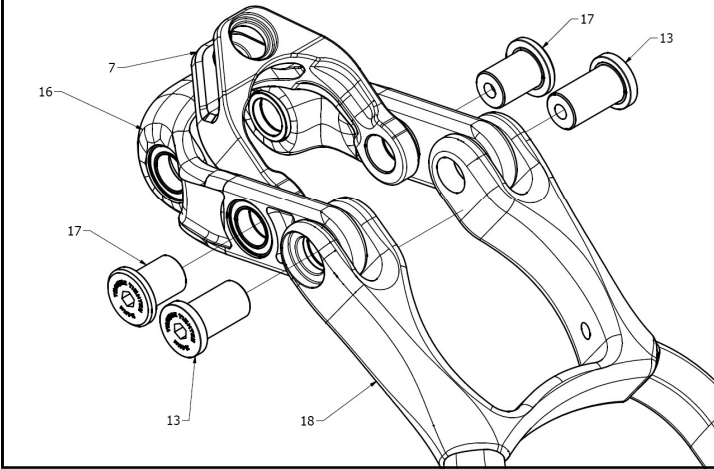
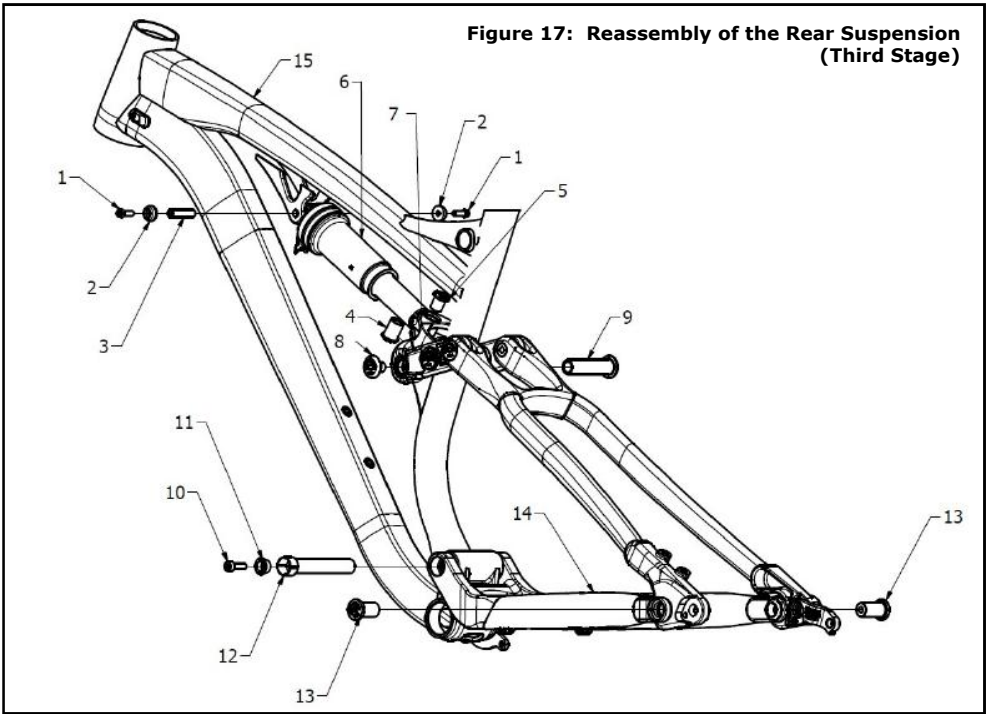

Figure 17: Reassembly of the Rear Suspension (Third Stage)



6.3.2 To re-assemble the Chain-stays (14) and Bearings (20) into the Main Frame (15) - First Stage.

Before inserting the bearings, make sure all the components are clean from dirt and have been thoroughly de-greased. Apply a small amount of Loctite 638 to the outside diameter of the bearing and to the inside mating bore of the main Frame (15). Using the press tools shown in Figure 15, insert the Enduro 15826-2RS-MAX bearings (20) into both sides of the Main Frame (15). Ensure the spacer (21) is located between the bearings (20).

Referencing figure 16, apply either SKF LGAF 3E or Castrol Optimol T paste to all faces of the shield washers (19), Pivot Pin (12) and Screw (10). Place the Shield Washers (19) alongside the Bearings (20). Insert & align the Chain-Stays (14) between the Washers (19). Insert the Pivot Pin (12) from the left side of the Chain-Stays (14). Screw the Pivot Pin (12) into the thread in the right side of the Chain-Stays (14). Insert the Tapered Sleeve (11) and screw in the M6 x 20 long Capscrew (10).

Using a 6mm Socket, first torque tighten the right side of the Pivot Pin (12), to the recommended torque settings (refer to the Tightening torque settings in Section 8.0). Then tighten the M6 x 20 long Capscrew (10), again to the recommended torque settings (refer to the Tightening torque settings in Section 8.0). Wipe off any excess grease from around the chain-stays and seat-stays.

6.3.3: To re-assemble the link (16), shock extender (7) & Seat-stay (18) onto the main frame (15) - Second & Third Stages.

IMPORTANT: Prior to reassembly of the Seat-Stay (18) to the Link (16), make sure the seat tube of the main frame (15, not shown for clarity) is inside of the assembly, as in figure 18. Also make sure the link is correct side up, as per figure 17.

Starting with the Seat-stay (18) and the Link (16), reference figure 24, first check that the shield washers are in place in the Link (see items 2 & 3 in figure 12) and apply either SKF LGAF 3E or Castrol Optimol T anti-fret paste to the contacting faces between the shield washers and Seat-stay (18). Then ensure that the shield washers in the Link (16) are not pushed out, as you place the seat-stay (18) inside it. Then pass an M15 x 26 long flanged alloy screw (13) through the right side of the seat-stay (18), the adjacent shield washers (items 2 & 3, figure 16), and the bearing in the Link (16). Using the 5mm A/F Allen Key, torque tighten the M15 screw (13) to the recommended torque settings (refer to the Tightening torque settings in Section 8.0). Repeat that task to assemble the left side of the seat-stay (18) to the H-link (16), also ensuring that the other shield washer in the Link (16) is not pushed out.

Next, to assemble the shock extender (7) and the Link (16), reference figure 17 (Main Frame 15 not shown for clarity), first check that the shield washers are in place in the Link (see items 2 in figure 12) and apply either SKF LGAF 3E or Castrol Optimol T anti-fret paste to the contacting faces between the shield washers and shock extender (7). Then ensure that the shield washers in the Link (16) are not pushed out, as you place the shock extender (7) inside them. Then pass an M15 x 20 long flanged alloy screw (17) through the Link (16), the bearing in Link (see items 1, figure 14), the adjacent shield washer, & into the thread of one arm of the shock extender (7). Using a 5mm A/F Allen Key, torque tighten the M15 Flanged Screw (17)

WHYTE Service Manual

to the recommended torque settings (refer to the Tightening torque settings in Section 8.0). Repeat that task to assemble the other arm of the shock extender (7) to the Link (16), also ensuring that the other shield washer in the Link (16) is not pushed out.

Next, to assemble the Link (16) to the Main Frame seat tube (15), reference figure 17, check that the shield washers are in place on the inside of the bearings that are installed in front of the Link (16), reference figure 12 items (2) and apply either SKF LGAF 3E or Castrol Optimol T anti-fret paste to the contacting faces between those shield washers and the link mounting on the main frame seat tube (15). Insert the Link (16) between the Main Frame seat tube (15). Then pass a Pivot Pin (main frame link mount) x 61 long (9) through the Link (16), the bearing in Link (1, figure 12), the adjacent shield washer, & through the Main Frame link mounting (15). Screw in, from the left side of the link (16), an M12 x 20 long Flanged Screw (8) . Using a 6mm A/F Allen Key, torque tighten the M12 Flanged Screw (8) to the recommended torque settings (refer to the Tightening torque settings in Section 8.0). Wipe off any excess grease from around the main frame (15) and the Link (16).

Finally to assemble the Chainstays (14) to the Seat-Stays (18), reference figure 18, check that the shield washers are in place on both sides of each Seat-stay leg (18) (see items 2 & 3 in figure 13) and apply either SKF LGAF 3E or Castrol Optimol T anti-fret paste to the contacting faces between those shield washers and the Chain-stays (14). Ensure that those shield washers are not pushed out, as you lower the Seat-stays (18) into the Chain-stays (17). Pass an M15 x 28 long Flanged Screw (12) through each Chain-stay (17) and Seat-stay leg (18). Using the 5 A/F Allen key, torque tighten those screws to the recommended torque settings (refer to the Tightening torque settings in Section 8.0). Wipe off any excess grease from around the chain-stays (17) and seat-stays (18).

6.3.4 To re-assemble the rear shock (6) into the frameset.

Reference figure 17. Take the Rear Shock Absorber (6) and apply either SKF LG/AF 3E or Castrol Optimol T anti-fret paste onto the side faces of the shock bushes, that contact the Main Frame (15) and Shock Extender (7). Slide the front of the Rear Shock Absorber (6) into the Main Frame (15) and Shock Extender (7).

IMPORTANT. Ensure the damper is the correct way up, with any dials and levers facing downwards and towards the front of the frameset, reference figure 18.

Make sure that the Ø8mm holes in the Main Frame (15) and the front of the Rear Shock Absorber (6) are all concentric with each other, and push the Ø8mm x 31mm long Hollow Pivot Pin (3) all the way through. Place a Collar

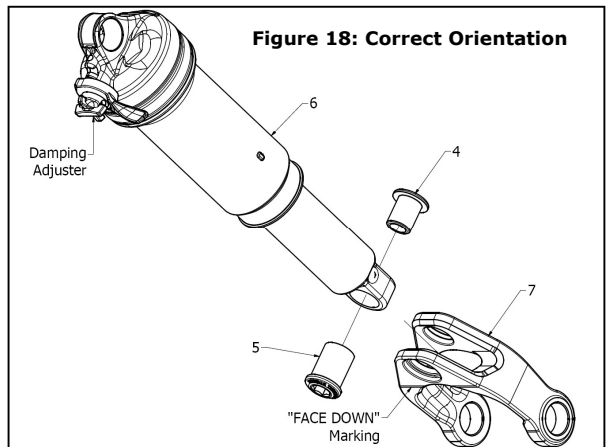

WHYTE Service Manual

(2) over both ends of the Ø8mm x 31mm long Hollow Pivot Pin (3) and screw in an M5 x 16mm long Socket-head Cap-screw (1) into both ends of the Pivot Pin (3). Using the T-25 Torx® Keys, torque tighten the M5 Cap-screws to the recommended torque settings (refer to the Tightening torque settings in Section 8.0).

Next, make sure that the 12mm holes in the Shock Extender (7) line up with the rear end of the Rear Shock Absorber (6). Insert the Flanged Nut M12 x 19mm long (4) & screw in the Flanged Screw M12 x 15mm long (5). Using the 6mm AF Allen Key and the 8mm AF Allen Key, torque tighten the Flanged Nut M12 x 19mm long (4) into the Flanged Screw M12 x 15mm long (5), to the recommended torque settings (refer to the Tightening torque settings in Section 8.0). Wipe off any excess grease from around both ends of the shock absorber (6).

7.0: SERVICING THE WHYTE MODULAR DROPOUT SYSTEMS.

7.1: Removing the Modular Rear Dropouts

Tools Required: 2mm Allen Key, 3mm Allen Key & 4mm Allen key

These Rear Drop-outs are a modular design, that can either be replaced if damaged or converted to one of two different types of through-axle products, ie: Shimano E-Thru or SRAM Maxle 148mm. Contact your local Whyte dealer to purchase either a replacement hanger or a conversion kit.

7.1.1: Shimano E-Thru System

Reference figure 19. The Rear Derailleur Hanger (2) is attached to the Right Side of the Seat-stay (18) by one Countersunk M4 Cap Screw (1). To remove the Rear Derailleur Hanger (2), using the 3mm Allen Key undo that Cap Screw (1) and remove it together with the Rear Derailleur Hanger (2). Also, to remove the Adjuster (4), using the 2mm Allen Key undo the Grub Screw (3) and remove it together with the Adjuster (4). Take care not to loose any of the components.

7.1.2: SRAM Maxle 148mm "Boost" System

Reference figure 20. The Rear Derailleur Hanger (4) is attached to the Right Side of the Seat-stay (18) by one M4 Countersunk Cap Screw (3). To remove the Rear Derailleur Hanger (4), using the 3mm Allen Key undo that Cap Screw (3) and remove it, together with the Rear Derailleur Hanger (4). To remove the Axle Nut (6), using the 2mm Allen Key undo the Grub Screw (5) and remove it, together with the Axle Nut (6). Moving across to the Left Side of the Seat-stay (18), again using the 4mm Allen Key undo the M5 Countersunk Cap Screw (2) and remove it, together with the Drop-out Spacer (1), from the assembly. Take care not to loose any of the components.

7.2: Re-assembling the Modular Rear Dropouts onto the Swinging Arm

Tools Required: 2mm Allen Key, 3mm Allen Key (1 off each, fitted to a 1Nm to 5Nm Torque Wrench)

It is important to make sure that all components are clean and free from mud, old grease and other dirt, which could prevent them from fitting together perfectly.



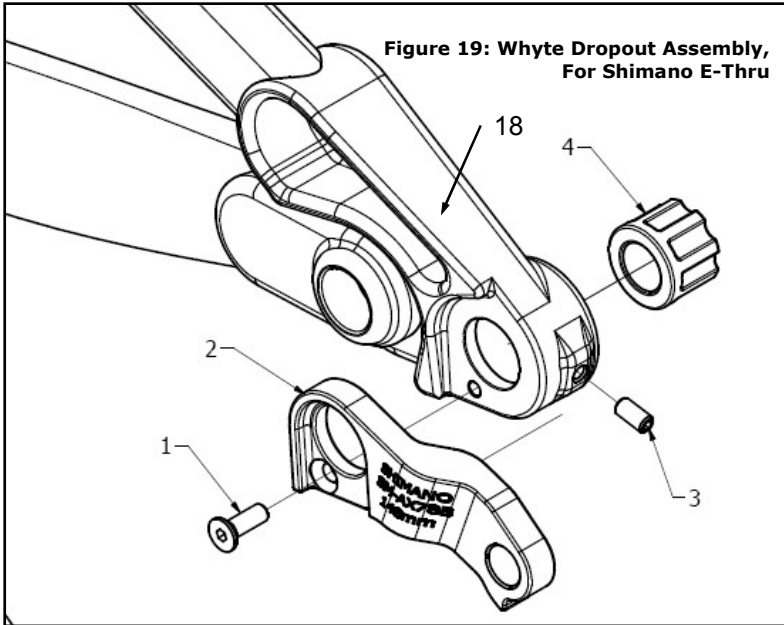

Item	Description
1	M4 x 16mm long Countersunk Head Screw
2	Rear Derailleur Hanger, for Shimano E-Thru Direct Mount (Grey Colour)
3	M4 x 8 long Grub Screw.
4	Axle Nut, for Shimano E-Thru

7.2.1: Shimano E-Thru System

Reference figure 19. Loosely assemble all the parts as shown, making sure the screws (1) & (3) are correctly positioned, **be very careful not to cross-thread this, on it's way in.** Insert the rear wheel and the Shimano E-Thru Rear Axle. Adjust the axle as per the Shimano Technical Service Instructions SI-27U0A-001-00. Whilst adjusting the Rear Axle, make sure the nose of the M5 Grub Screw (3) is aligned with one of the slots in the Axle Nut (4). Having tightened the Rear Axle, using the Torque Wrench, tighten the M5 Grub Screw (3) to the correct torque as specified in Section 8.0. **DO NOT OVERTIGHTEN**, since the thread of the Screw (1) is very small.

Remove the rear wheel and using the Torque Wrench, tighten the M4 Countersunk Head Screw (1) to the correct torque as specified in Section 8.0. **DO NOT OVERTIGHTEN**, since the thread of the Screw (1) is very small.

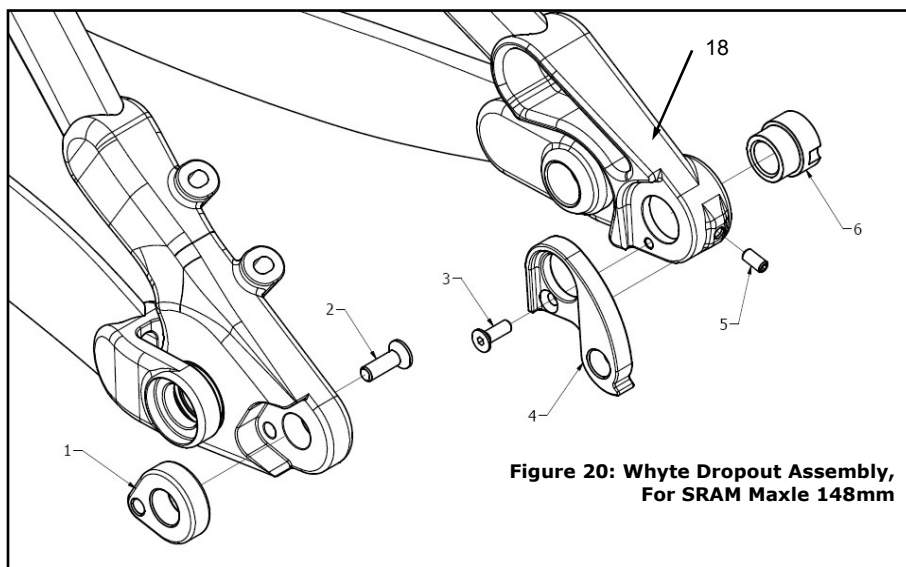

**Figure 20: Whyte Dropout Assembly,
For SRAM Maxle 148mm**

Item	Description
1	Dropout Spacer (8mm wide) Left Side, for SRAM Maxle 148mm (Gunmetal Colour)
2	M5 x 16mm long Countersunk Head Screw
3	M4 x 12mm long Countersunk Head Screw
4	Rear Derailleur Hanger, for SRAM Maxle 148mm (Black Colour)
5	M4 x 8 long Grub Screw.
6	Axle Nut, for SRAM Maxle 142mm (Black Colour)

7.2.2: SRAM Maxle 148mm "Boost" System

Reference figure 20. Loosely assemble all the parts as shown, making sure the Screws (2), (3) & (5) are correctly positioned, **be very careful not to cross-thread these, on their way in**. Insert the rear wheel and the SRAM Maxle, as per the SRAM User Manual 95-4315-004-000. Whilst tightening the SRAM Maxle, make sure the nose of the M5 Grub Screw (5) is aligned with the single slot in the Axle Nut (6). Using the Torque Wrench, tighten the M5 Grub Screw (5) to the correct torque as specified in Section 8.0. . **DO NOT OVERTIGHTEN**, since the thread of the Screw (5) is very small.

Remove the rear wheel and using the Torque Wrench, tighten the M4 Countersunk Head Screw (3) to the correct torque as specified in Section 8.0. Also tighten the M5 Countersunk Head Screw (2). **DO NOT OVERTIGHTEN**, since the thread of the Screws (2) & (3) are very small. Finally, if necessary, re- adjust the SRAM Maxle Rear Axle as per the SRAM User Manual 95-4315-004-000.

WHYTE Service Manual

8.0: WHYTE INTER GRIP SEAT CLAMP SERVICE

Tools Required: 5mm AF Allen Keys (2 off, 1 fitted to a 3Nm to 15Nm Torque Wrench)
M6 cap-screw at least 40mm long or a small size flat blade screwdriver
SKF LGEP2 or Castrol Spherol AP3 or Finish Line Teflon White Lithium Complex grease

Reference figures 21 to 35. To service the Inter Grip seat clamp, carefully follow these procedures otherwise there is a risk of damaging some of the components.

Item:	Description
1	M6 x 30mm Capscrew
2	Plain Sleeve
3	'O' ring
4	Grip Pad
5	Threaded Sleeve
6	Main Frame
7	Seat Post

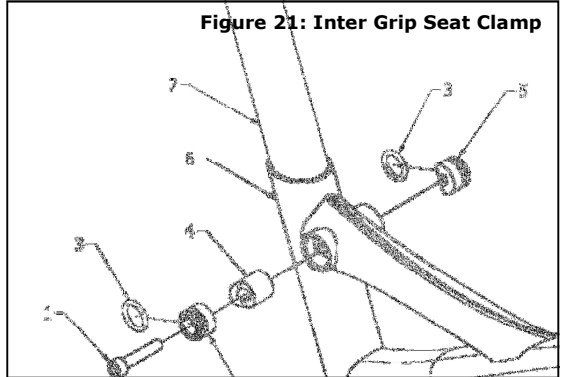

Especially remove and replace the seat-post (7) in the specified order.

Figures 22 to 23. From the right side of the Main Frame (6) unscrew & remove the M6 x 30 long Capscrew (1). Replace that with the longer capscrew and screw loosely into the Threaded Sleeve (5).



Figures 24 & 25. Push the Threaded Sleeve (5) all the way out of the opposite side of the Main Frame (6).

Figures 26 to 27. Move to the left side of the Main Frame (6). Place the M6 x 30 long Capscrew (1) diagonally through the Grip Pad (4) and onto the Plain Sleeve (2). Then push the Plain Sleeve (2) all the way out of the right side of the Main Frame (6).



WHYTE Service Manual

Figures 28 & 29. Remove the Seat Post (7) all the way out of the Main Frame (6). Remove the Grip Pad (4) from either side of the Main Frame (6). The 'O' rings (3) may be removed from the Threaded Sleeve (5) and the Plain Sleeve (2), using the small size flat blade screwdriver.



Figure 28



Figure 29

To re-assemble the Inter Grip seat clamp, coat the 'O' rings (3) with a small quantity of grease. Carefully fit the 'O' rings (3) into the grooves in the Threaded Sleeve (5) and the Plain Sleeve (2). Also place some grease onto the threaded end of the M6 Capscrew (1).

Figures 30 & 31. Place the Grip Pad (4) into the hole in the Main Frame (6) such that the curved face is towards the seat tube in the Main Frame (6). Insert the Seat Post (7) to help align the Grip Pad (4).



Figure 30



Figure 31

Figures 32 & 33. From the left side of the Main Frame (6), insert the Plain Sleeve (2) and make sure the 45° angled edge on the Plain Sleeve (2) touches the 45° angled edge on the Pad (4).

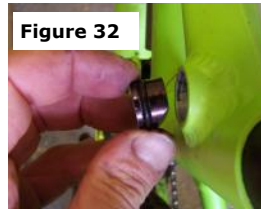

Figure 32

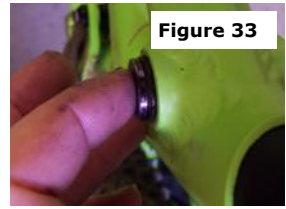

Figure 33

Figures 34 & 35. Move to the right side of the Main Frame (6) and insert the Threaded Sleeve (5), aligning the 45° angled edge to touch the 45° angled edge on the Grip Pad (4). Place the M6 Capscrew (1) through the Threaded Sleeve (5), the Pad (4) & screw into the Threaded Sleeve (5).



Figure 34



Figure 35

Both of the Sleeves (2 & 5) should be nearly flush with the edge of the hole in the Main Frame (6) when the assembly goes tight. If this is not the case, one or other of the four 45° angled edges are not touching each other, so re-align as necessary to make sure both of the Sleeves (2 & 5) are nearly flush.

Then follow the instructions in section 3.2 to set the height and direction of the Seat Post (7).



WHYTE Service Manual

9.0: INTERNAL CABLES & HOSES

Tools Required: Small size flat blade screwdriver
 Short length of inner gear cable
 A torch or front bicycle light

General Note: Take care if refitting or replacing the rubber covers, since too much force will damage them.

9.1 To replace cable or hose outers.

Reference figures 36 to 41. When replacing outer cables and or brake hoses, most of the holes in the frame are large enough (25mm long x 8mm wide) simply to manipulate the outer cable or brake hose into or out of the hole. However the two holes for the rear derailleur cable in the chain-stay are necessarily small, therefore the following method is needed to refit a new outer cable:

Figures 36 & 37: Using a piece of inner cable, feed into the entrance hole in the right-side chain-stay, near the drop-out, then through the exit hole at the opposite end of the chain-stay. This will probably need several attempts pushing to & fro to find the hole, please be patient!

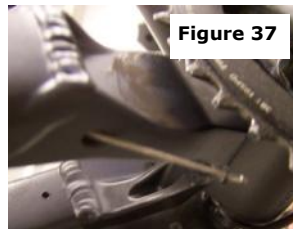
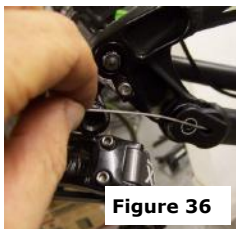

Figures 38 & 39: At the drop-out end, push the outer cable onto the inner cable and then feed the outer cable into the chain-stay following the same path as the inner cable.

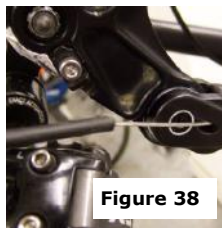

Figure 40: Make sure the inner cable is held tight where it emerges from the chain-stay at the opposite end, otherwise it will be pushed out. Eventually the outer cable will reach the front of the chain-stay. Then manipulate both the inner cable and the outer cable, whilst also pushing the outer cable forwards with a lot of force and the outer cable should also find the exit hole.

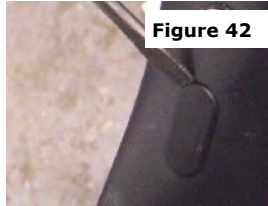

Figure 41: Push the outer cable all the way through the exit hole and finally remove the inner cable.

9.2 To fit a "Dropper" seat-post with internal hose. Take care to abide by safety recommendations.

 **CAUTION: Before installing the seat-post, carefully consult the product manufacturer's own instructions.**

Reference figure 42. First prise out the two blank plastic covers near the bottom bracket with a small screwdriver.



Reference figure 43. Carefully unscrew the hose from the remote actuator.

Reference figure 44. Insert the disconnected hose end into the top of the seat tube and push down towards the bottom bracket.

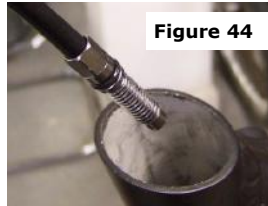

Reference figure 45. Manoeuvre the hose end out of the slot at the front of the seat tube.

Reference figure 46. Push two rubber grommets over the end of the hose. Make sure the narrower end of the first grommet is facing the seat tube, whilst the narrower end of the second grommet is facing the down tube.

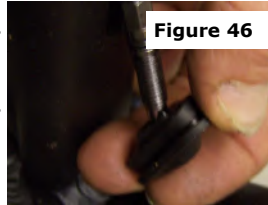

Reference figure 47. Insert the hose end into the down tube and push the hose up towards the head tube. The grommets will have to be pushed further along the hose to do this.



Reference figure 48. Prise out the rubber grommet on the side of the down-tube, near the head tube, with a small screwdriver.



Reference figure 49. Manoeuvre the hose end out of the slot at the top of the down tube. Use a small hook to assist with capturing the hose end and drawing it towards the slot. A torch would help to locate the hose end.

Reference figure 50. Push the rubber grommet over the end of the hose. Make sure the nar-



WHYTE Service Manual

lower end of the grommet is facing the down tube.

Reference figure 51. Insert the seat-post into the seat tube and simultaneously pull the hose through the frame.

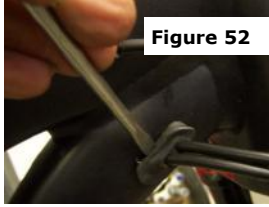

Figure 52



Figure 53

Reference figure 52. Insert all three rubber grommets into the frame slots. Use a small screwdriver with care not to split the rubber.

Reference figure 53. Cut the hose to length and follow the product manufacturer's instructions to re-assemble and bleed the hydraulic system.

10.0: TORQUE SETTINGS

Torque explained: If no suitable Torque Wrench is available a Torque of 5 lbf.ft can be obtained by applying a force of 5lb, with a Spring Balance, to the end of a spanner, 1 Foot in length.

Rear Suspension	Nm	lbs.ft
M12 Flanged Screw & Flanged Nut	16.1 (Min) - 19.9 (Max)	11.9 (Min) - 14.7 (Max)
M5 Socket-head Cap Screw (T-25 Torx®)	5.0 (Min) - 6.0 (Max)	3.7 (Min) - 4.4 (Max)
M12 x 20 long Alloy Flanged Screw	15.0 (Min) - 17.0 (Max)	10.5 (Min) - 12.5 (Max)
Pivot Pin (link mount, main frame) x 61 long	15.0 (Min) - 17.0 (Max)	10.5 (Min) - 12.5 (Max)
M15 x 20 long Alloy Flanged Screw	15.0 (Min) - 17.0 (Max)	10.5 (Min) - 12.5 (Max)
M15 x 26 long Alloy Flanged Screw	22.0 (Min) - 26.0 (Max)	16.2 (Min) - 19.2 (Max)
M15 x 87 long Pivot Pin	9.0 (Min) - 11.0 (Max)	6.1 (Min) - 7.5 (Max)
M6 x 20 long Socket Head Capscrew	9.0 (Min) - 11.0 (Max)	6.1 (Min) - 7.5 (Max)
Rear Dropout Assemblies		
M4 Countersunk Screws	4.2 (Min) - 4.6 (Max)	3.1 (Min) - 3.4 (Max)
M5 Countersunk Screws	4.8 (Min) - 5.2 (Max)	3.6 (Min) - 3.8 (Max)
M5 Grub Screw	2.2 (Min) - 2.6 (Max)	1.6 (Min) - 1.9 (Max)
Seat Post Clamp		
M6 Cap Screw	12 (Min) - 14 (Max)	8.9 (Min) - 10.3 (Max)

IMPORTANT: For all other torque settings, refer to the specific manufacturers information bundled with this manual, or alternatively, refer to the specific manufacturers website for further information.

11.0: OWNER'S NOTES

www.whyte.bike

